

SECTION A-A

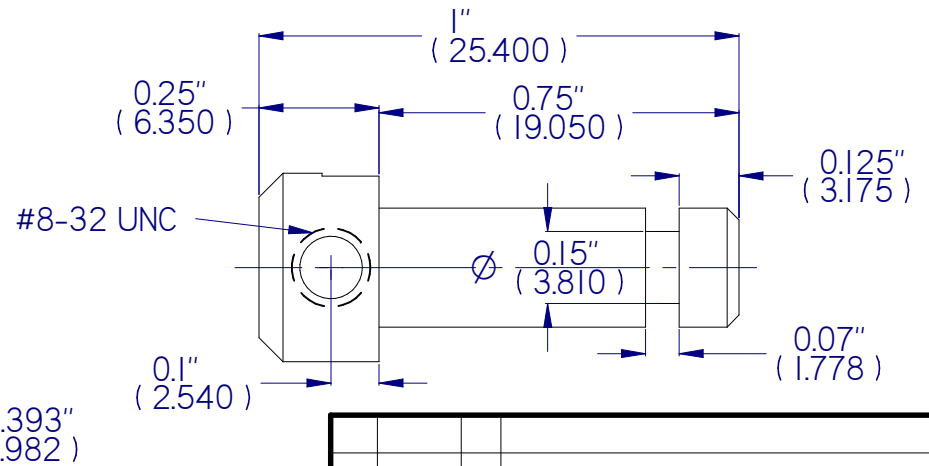

MATERIAL Steel, 1018	
CONDITION	
FINISH	
TOLERANCES $\pm 0.004$ " ON LENGTHS, $\pm 0.002$ " ON DIAMETERS, $+0.002/-0.000$ " REAMED HOLES, $+0.004/-0.000$ " DRILLED HOLES, $\pm 0.5^\circ$ ON ANGLES UNLESS NOTED OTHERWISE	
TREATMENT	
PROCESS	
DWG NO.	DRAWING Quick Change Tool Holder

DIMENSIONS ARE IN INCHES UNLESS OTHERWISE SPECIFIED

REV	DATE	BY	DESCRIPTION
DRAFT FILE CREATED: 4/27/2018 LAST SAVED 4/27/2018			
DRAWN YAHN GRAY		APPROVED RICK ALEXANDER	

REV. E	SHEET QC
-----------	-------------