

Tips & Techniques

from
the

FASTEST

Pinewood Derby[®] Racers

in
the

World!

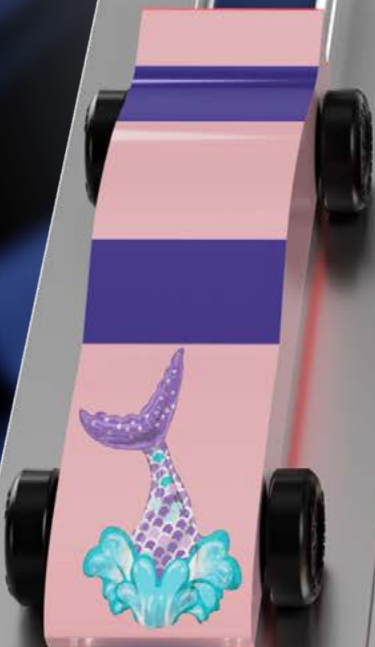

Purpose of Pinewood Derby®

The primary purpose of Pinewood Derby® is for the Scout and parent (hereafter referred to as Race Team) to spend **TIME together!** A fast car takes considerably more **TIME** to build than a slow one. Likewise, a beautiful or cool car takes much more **TIME** than a plain or ugly one. Therefore, a fast or beautiful car represents a success story of Pinewood Derby's® primary mission!

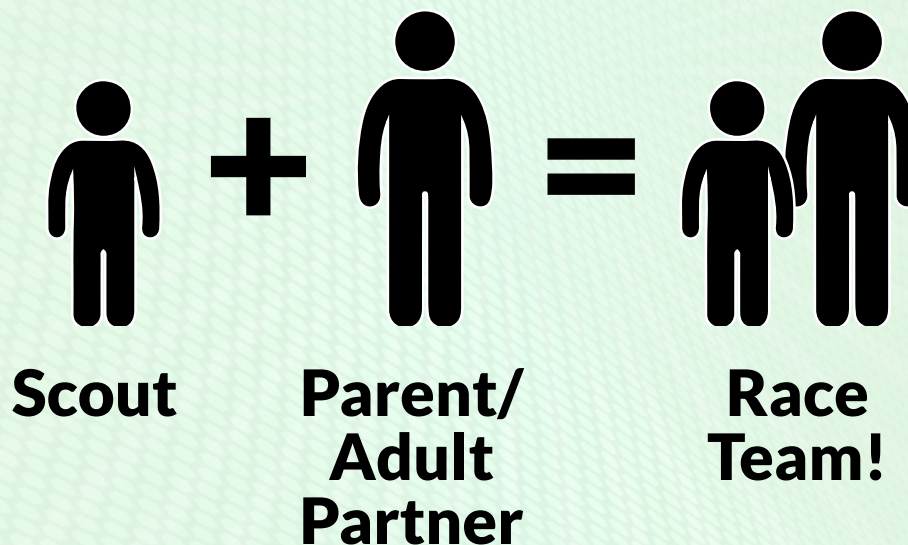

Remember:

The Scout is not supposed to build the car.

The parent/adult partner is not supposed to build the car.

They're supposed to build it **TOGETHER!**

Purpose of This Book

Pinewood Derby® has been a staple of, and synonymous with, Cub Scouting for nearly 70 years. While things have certainly changed over time as designs and techniques have improved and cars have become progressively faster, the birth of the national professional adult racing leagues in the early 2000s ushered in a **new level of Pinewood Derby® car performance**. These leagues, consisting of racers from all over the country with varying backgrounds (engineers, scientists, mechanics, educators, computer programmers, technology enthusiasts, etc.), have raised the bar on what makes a fast Pinewood Derby® car.

There are many books on how to make Pinewood Derby® cars from a Cub Scout perspective. This book explores how league racers design and construct their cars, along with tips on how to apply these techniques to Race Team (Scout) built cars.

This book illustrates what the fastest Pinewood Derby® racers do to compete. It is not necessary, nor in some cases is it feasible, for a Race Team to follow every step outlined in this book. Instead, it is a guide to help the **Race Team make a faster car** by incorporating the techniques they feel they can implement. A Race Team that uses just a few of these methods will spend more **TIME** together and build a faster car!

This book is a living/growing document. If you have any ideas or suggestions to improve it, please let us hear from you! Email us at: book@turboderby.com



Working with wood and other materials includes the risk of injury and damage. This book does not guarantee the steps in this book are safe for everyone. This book is offered without warranties or guarantees of any kind, expressed or implied; the authors and Turbo Derby LLC disclaim any liability for injuries, losses, or damages caused in any way by the content of this book or the use of tools and techniques offered by this book and Turbo Derby. Pinewood Derby® is a registered trademark of the Boy Scouts of America. This book is independently published by Turbo Derby LLC and is not sponsored, endorsed, or affiliated with the Boy Scouts of America, whose trademarks appear for informational purposes only. © 2022 Turbo Derby LLC, all rights reserved. It is a violation of United States copyright laws to make copies in any form or media of the contents of this book for commercial or educational purposes without written permission from the publisher, Turbo Derby LLC.

Contributors to This Book

A huge thank you to the following Professional League Racers and Pinewood Derby® experts who contributed to this book:

Dan Inman

DWS Racing



- 2025 Overall World Champion
- 2025 Overall National Champion
- 2024 Overall World Champion
- 2023 Overall World Champion
- 2023 Multiple Class World Champion
- 2022 Overall World Champion
- 2022 Multiple Class World Champion
- 2022 BASX Mini National Champion
- 2021 Overall World Champion
- 2021 Multiple Class World Champion
- 2020 Overall National Champion
- 2020 Multiple Class National Champion
- 2017-2019 Seven Class World Championships
- 250+ First place professional finishes
- Featured in [Popular Science](#) magazine

Brian Crane

HurriCrane Racing

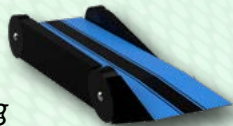

- 26x National Class Championships (2015-2022)
- 2022 Three Class World Champion
- 2022 Overall National Champion
- 2021 Overall National Champion
- 2021 Four Class World Champion
- 2020 Three Class World Champion
- 300+ First place professional finishes
- 60+ Track records

Anthony Castoro

Castoro Racing



- 2022 Association of Pinewood Racers (APR) Masters of Gravity seven class champion
- 2021 Association of Pinewood Racers (APR) Masters of Gravity two class champion
- 2021 Race for Veterans 1000 Champion
- 2020 BASX Mini Class World Champion
- 2019 Box Stock Class World Champion
- 2019 National Pinewood Derby Racing League (NPWDRL) & APR Rookie of the Year

Mike McGuire

Reece Racing



- 2025 Multiple Class World Champion
- 2025 Multiple Class National Champion
- 2024 Multiple Class World Champion
- 2024 Multiple Class National Champion
- 2022 BASX Class World Champion
- 2022 Association of Pinewood Racers (APR) Masters of Gravity Overall Champion
- 2022 West Coast Grand Prix Two Class Champion
- 2019 Nationals Box Stock Class Champion
- 2018 National Pinewood Derby Racing League (NPWDRL) & APR Rookie of the Year

Benji Dean

JBD Racing



- 2022 Nationals Three Class Champion
- 2021 BASX Class World Champion
- 2019 Two Class World Champion
- 2017 BASX Class World Champion
- 2016 Overall World Champion
- 2014 Overall World Champion
- 2014 Overall National Champion
- 30+ First place professional finishes
- 15+ Track records

Jay Monk

Mojo Racing



- 3x Class World Champion
- 10x National Pinewood Derby Racing League (NPWDRL) Class Champion
- 4x Association of Pinewood Racers (APR) Class Champion
- 70+ First place professional finishes
- 20+ Track records

A note to parents/adult building companions:

When asked what kind of car they want, most Cub Scouts (especially first-time racers) will inevitably say a “cool car,” such as the Batmobile, a rocket ship, a mermaid princess, etc. They will hold fast to this desire **until the racing starts**, then all they want is a **fast one!** Keep this in mind when planning the car with your Scout. Most of the speed is in the wheels, axles, and weight, so if fast is the goal, focus your attention there!

Table of Contents

<u>Chapter 1:</u> The Foundations of Speed.....	7
<u>Chapter 2:</u> The Keys to a Fast Car.....	8
<u>Chapter 3:</u> Rules Rules Rules.....	9
<u>Chapter 4:</u> Rail Riding & the Anatomy of a League Car.....	10
<u>Chapter 5:</u> Wheels.....	13
<u>Chapter 6:</u> Axles.....	20
<u>Chapter 7:</u> Weighting	28
<u>Chapter 8:</u> Alignment	33
<u>Chapter 9:</u> Aerodynamics	38
<u>Chapter 10:</u> Body	48
<u>Chapter 11:</u> Lubrication	58
<u>Chapter 12:</u> Assembly	63
<u>Chapter 13:</u> Internet: The Wild West of PWD Info	67
<u>Chapter 14:</u> Race Day	69
<u>Chapter 15:</u> League Racing	71
Plans Gallery.....	72

The Foundations of Speed

Three variables or principles limit the speed of a Pinewood Derby® car. Addressing each area results in faster cars!

Potential Energy - Pinewood Derby® cars are gravity powered. Their potential energy is the amount of energy available to be converted into motion or kinetic energy. Maximize potential energy by tweaking the amount and, most importantly, the location of the weight in the car. Learn how to address this foundation in the [Weighting](#) chapter.

Friction - Friction limits the use of available potential energy. Energy is lost from surfaces rubbing against each other. The wheels, axles, car body, track, and air are all sources of friction. Reducing friction is key to increasing speed and is addressed in detail in the [Wheels](#), [Axles](#), [Aerodynamics](#), [Alignment](#), [Body](#), and [Lubrication](#) chapters.

Rotational inertia - It takes a certain amount of energy to start a Pinewood Derby® car rolling down the track. Heavier objects need more energy than lighter objects. Reducing the car's rotational inertia leads to quicker starts and faster times. Reducing rotational inertia is discussed in detail in the [Wheels](#) chapter.

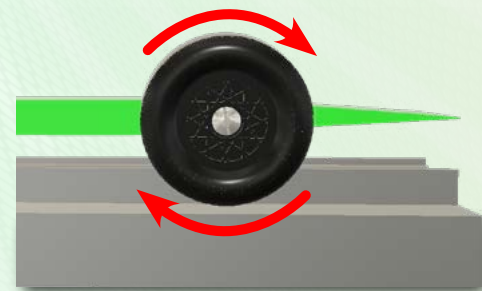
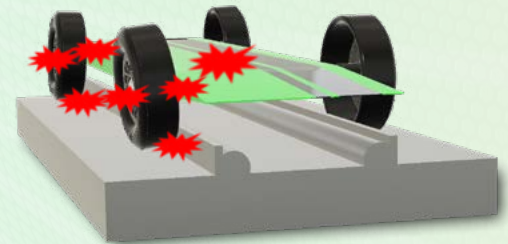
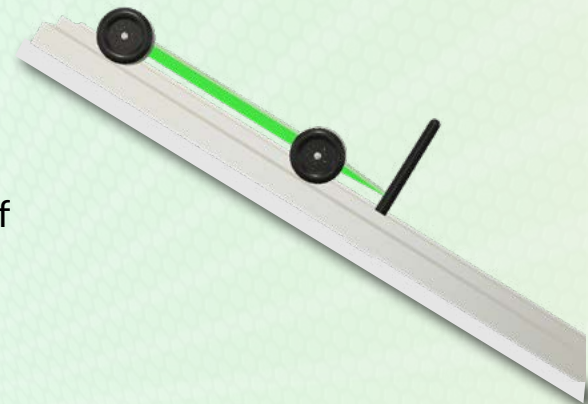

The Keys to a Fast Car

Maximize speed on your Pinewood Derby® Car by addressing these five key areas:

Wheels - Properly prepare the wheels by polishing their contact surfaces, which minimizes friction. If not prohibited, reducing both lateral and radial runout (wobble) and reducing the wheels' overall size and weight will minimize friction, drag, and rotational inertia.



Axles - Prepare the axles by polishing their contact surfaces, thus minimizing friction.

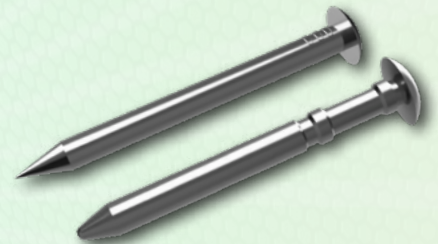

Weighting - Address both the amount AND location of the weight to maximize potential energy.

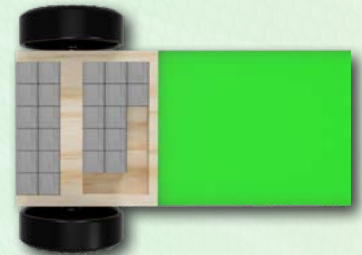

Alignment - The location and position of the axles in the car body are crucial to minimizing friction and therefore maximizing speed.

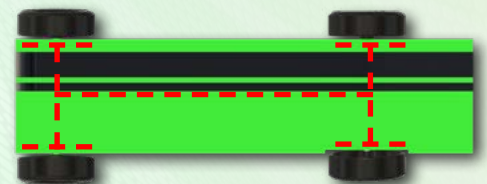

Aerodynamics - Construct the car to minimize aerodynamic drag.



Rules Rules Rules!!

The BSA Pinewood Derby® kits come with a set of basic rules. However, practically every BSA Pack, District, and Council (and racing league) will have its own regulations that supersede the rules in the box. Therefore, the rules can vary significantly between organizations, so familiarize yourself with them. Also, remember that rules are often open to interpretation and may be perceived differently by a Race Team and race officials. **If in doubt, ask** your organizer for clarification on any points of confusion. League racers approach the rules from the standpoint that if the rules don't expressly prohibit something, then it is allowed. **However, this may not be how your race officials will view things, and they will have the final say.** Your officials may take the view that the rules expressly state what is allowed rather than what isn't.

Some of the tips and techniques in this book **MAY NOT** meet your specific set of rules. So again, if in doubt, ask, or at least be prepared to make changes on race day!

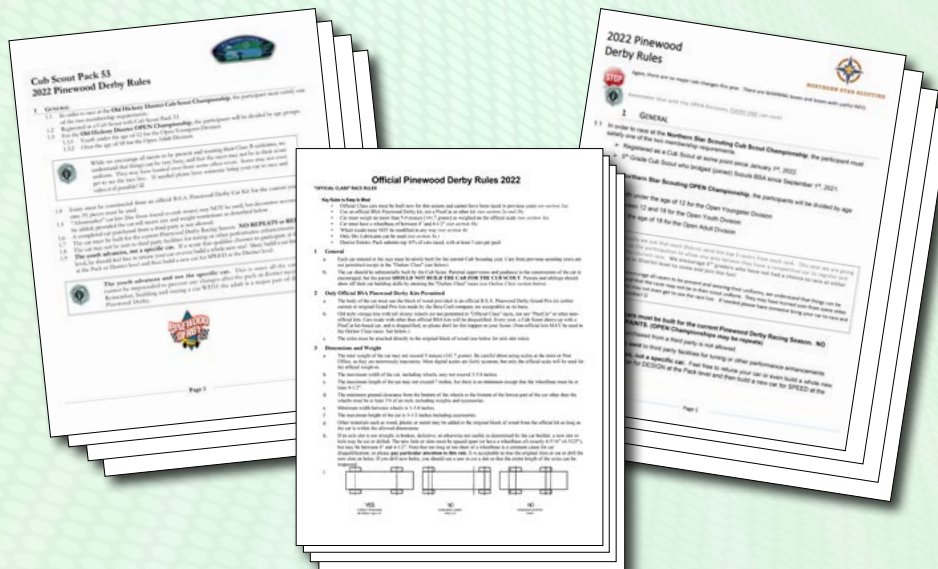

Rail Riding and the Anatomy of a Professional League Car

League Racers build the fastest Pinewood Derby® cars in the world. This section will give a broad overview of the features of a typical league car.

Over the years, as Pinewood Derby® racers pushed their weights back further to gain more potential energy, the cars became unstable and wiggled. This banging back and forth along the center rail slows the car down considerably. Racers discovered that if the car gently rubbed or steered into the center rail of the track, it would be more stable and, therefore, faster.

[Click here to watch how wiggling kills speed!](#)



Front wheel set to slightly steer the car into the center rail.

The slight friction generated by the front wheel rubbing the center rail slows the car **MUCH LESS** than a straight running, traditional car becoming unstable.

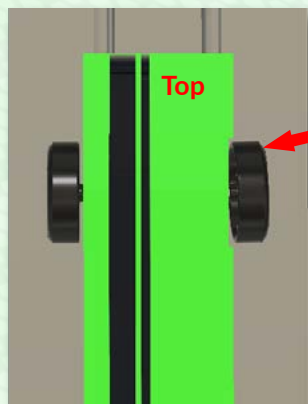

Steer is induced by turning the right front wheel inward (known as *toe-in*).

Tilting the wheel (known as *positive camber*) stabilizes it and reduces friction.

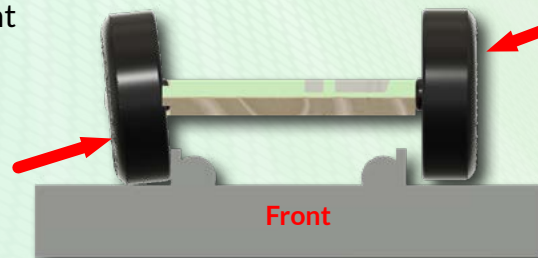

Non-steering front wheel raised or lifted slightly off track, significantly reducing rolling inertia.

There are two options for turning and tilting the front wheel, causing the car to steer into the rail.

OPTION 1: Drill the front axle hole at a compound angle that will impart camber (tilt) and toe (turn) into the front wheel, inducing the steer. Drilling the front axle hole at the proper angle can be difficult and limits the ability to adjust the amount the car steers; however, a tool discussed later in this book easily allows the drilling of steer into the car.

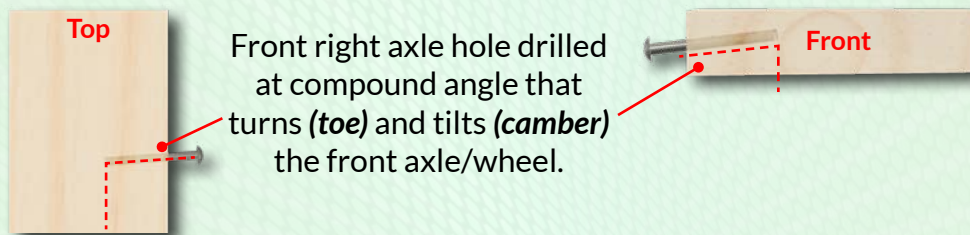

Some race rules prohibit the bending of axles. If running a rail rider setup, drilling the hole at the compound angle to induce steer is the only option.

OPTION 2: Pro racers prefer this option. Bending one of the front axles (usually the right front) induces the steer. The wheel tilts and turns inward toward the car body by twisting the axle. This amount needs fine-tuning; therefore, a groove is typically cut into the head of the axle so the racer can turn the axle using a flat-head screwdriver. Racers will roll their car down a slightly inclined surface to see how much it turns over a given distance (typically four feet). Setting the steer is discussed in more detail in the [Assembly](#) chapter.



Anatomy of a League Car

Below are key features of professional league racing Pinewood Derby® cars. These features are discussed in more detail in other chapters of this book.

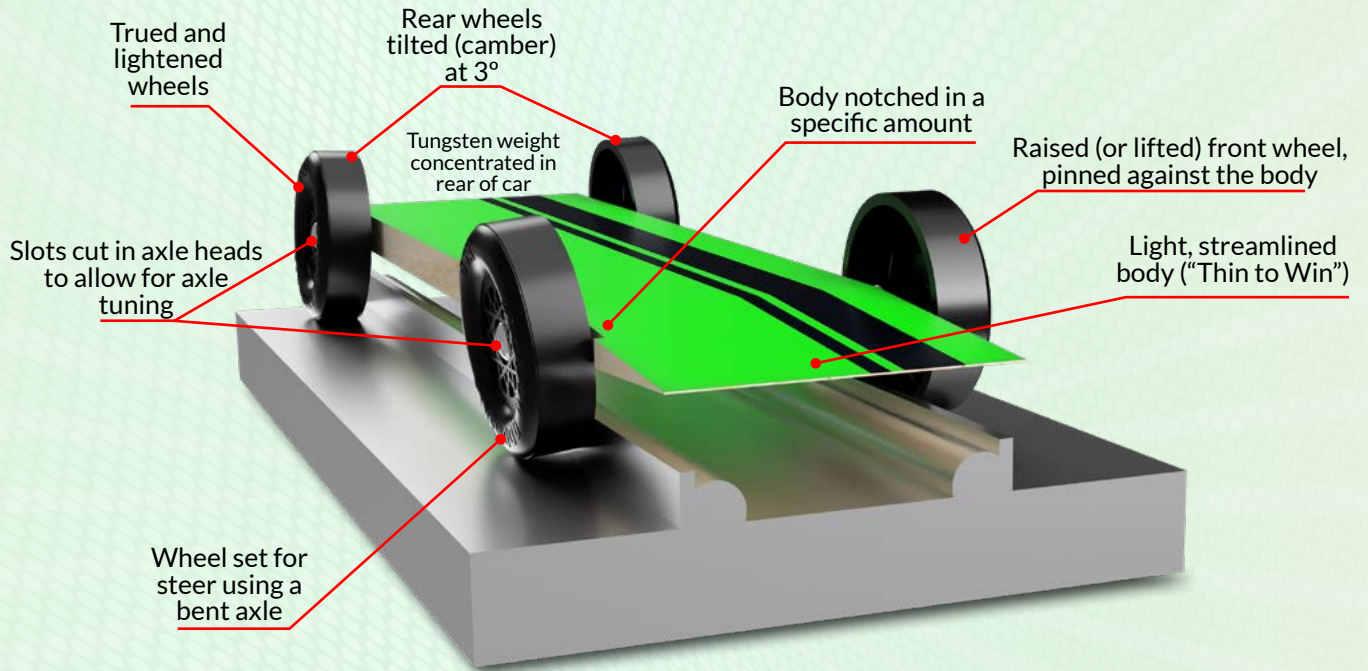

When not prohibited, these aerodynamic additions are utilized:

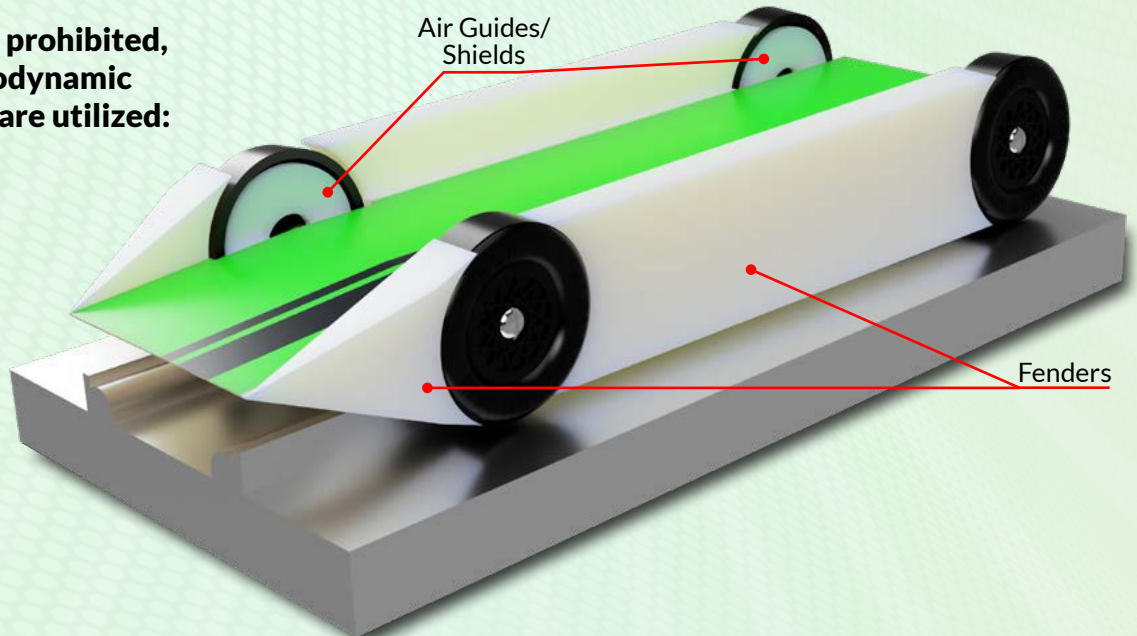

Wheels

Properly prepared wheels and axles, along with weighting, are where the majority of speed gains lie in a Pinewood Derby® car. As a result, League racers spend most of their time working on the wheels and axles.

The official BSA wheels leave much to be desired and need a fair amount of work to maximize their potential. The kits' wheels will have imperfections, such as rough areas, runout (high and low spots on the tread), etc. This chapter will focus on fixing these imperfections and maximizing the wheel's speed potential!



PRO TIP FROM HurriCrane Racing:

If your rules do not prohibit modified/lightened wheels, use them!

Stock vs. Modified wheels - Modified and lightened wheels significantly boost speed. Lighter wheels have a lower inertia coefficient. As a result, they begin rolling sooner and take less energy to start rolling than stock wheels. These lighter wheels translate into a faster start for the car and savings in energy that can be used to propel the car down the track! Additionally, these wheels experience less aerodynamic drag. Modified wheels are available for purchase [here!](#)



MODIFIED WHEELS

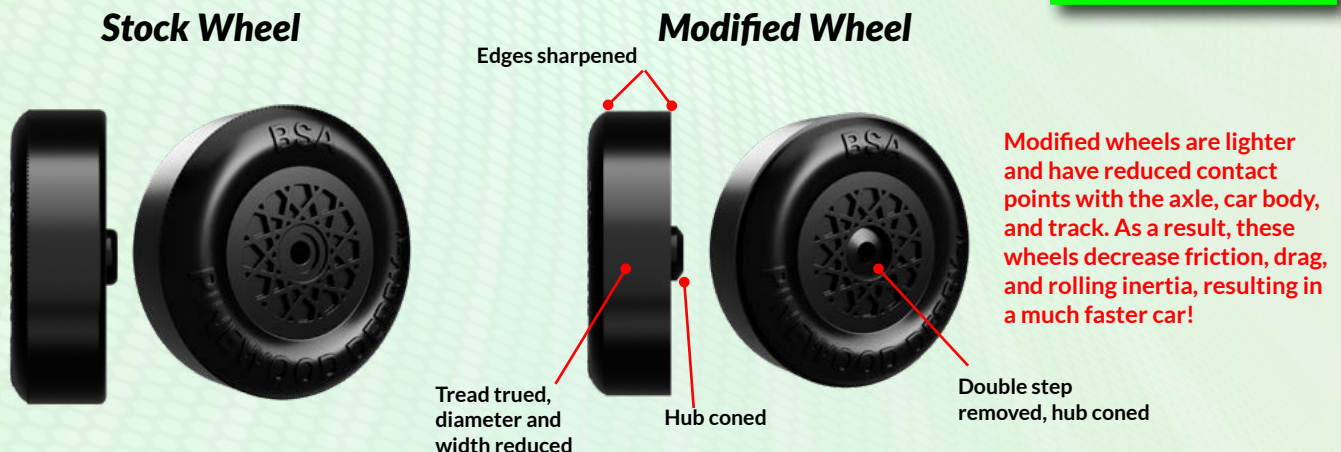

Both modified and unmodified wheels have five areas that need to be polished. They are:

- Tread
- Tread Edge
- Outer Hub
- Inner Hub
- Axle Bore



To maximize wheel speed you will need a few supplies and tools:

- Handheld power drill
- High grit (1000) sandpaper
- Cotton swabs (Qtips™)
- Microfiber cloth
- Paper towel or cotton cloth
- Method to hold the wheels in the drill
- Plastic polish
- Dish soap with a small bowl
- Wax (synthetic automotive wax will work)
- Fuzzy pipe cleaners



WHEEL PREP KIT

Optionally there are [kits](#) designed explicitly for this purpose and contain everything you need to create **professional, league-quality wheels!**

You will need a method to hold the wheels in the drill so they can be spun and polished. As of the writing of this book, the paper stalk of Target® brand cotton swabs will fit tightly into the BSA wheel bore. Cut off both ends and carefully insert the stalk into the wheel. There should be enough friction to hold the wheel while spinning to polish it. Alternatively, there are [tools](#) designed specifically for this purpose and are the **preferred method** for many league and Scout racers.



TURBO CHUCKS

If needed, add a little water to the swab stalk to get it to swell and fit tightly in the bore.



Wheel Preparation

Using your preferred method for holding the wheel in the drill, follow these steps:

STEP 1: Start with the wheel's tread edge. When using wheels straight from the kit, there can be flashing on the wheel from the manufacturing process. Use the high grit (1000) sandpaper to sand the edge of the wheel while spinning it with the drill. **Do not over-sand**; you want to sand just enough to remove the flashing. With modified wheels, you'll want to sand off any burrs from the cutting process but don't round over the edge. Next, use a wet paper towel or cloth to clean any plastic and sandpaper particles from the wheel. **This is the only step utilizing sandpaper on the wheels.**



On a modified wheel keep the edges sharp, don't round them.



PRO TIP FROM *Reece Racing*:

Don't sand your wheels aggressively with multiple grits of sandpaper. Every hand drill and most drill presses have a fair amount of runout (wobble) in their chuck. You'll sand this runout INTO the wheels, something you want to avoid. Instead, use polish to prepare the wheels.



STEP 2: Apply a small amount of polish to the microfiber cloth (or use a cotton swab). Spin the wheel, using light pressure, polish the tread edge with the microfiber/polish for 1-2 minutes. Use a wet paper towel, cotton cloth, or soft bristle toothbrush to clean any remaining polish on the wheel. **STOP BE CAREFUL** with the cloth near the

spinning drill as it can become entangled with the drill chuck, and pull fingers in with it. Cutting the microfiber or cotton cloth into smaller pieces or using a cotton swab can help reduce this risk. →

Polish the tread edge



Cutting the cloth in fourths can help keep it from becoming entangled in the drill chuck!

The target RPM for each polishing step is around 600; adjust the time accordingly if your chosen tool is slower or faster than this.

Unpolished



Polished



STEP 3: Repeat Step 2 on the inner hub for 1-2 minutes with the microfiber (or cotton swab) and polish. Use a wet paper towel,



cotton cloth, or soft bristle toothbrush to clean any remaining polish off the wheel. You can also rinse in a sink to remove the polish.



Inspect the tread edge and inner hub, ensuring the surfaces are smooth with no remaining flashing/burs and the plastic is shiny. A magnifying glass or [jeweler's loupe](#) is a handy tool for wheel inspection.

If you feel the plastic is not quite shiny enough, repeat the polishing steps, but do so in 30-second intervals.

STEP 4: Turn the wheel around to polish the tread. Apply a small amount of polish to the microfiber cloth (or cotton cloth). Spin the wheel, using light pressure polish the tread with the microfiber/polish



for 1 minute. Use a wet paper towel, cotton cloth, or soft bristle toothbrush to clean any remaining polish off the wheel. **You want the wheel treads to be smooth but NOT slippery, so don't overdo polishing the wheel tread.**

Unpolished



Polished



Polish the inner hub



JEWELER'S LOUPE

Polish the tread



STEP 5: Apply a small amount of polish to a cotton swab. While spinning the wheel, use medium pressure to polish the outer hub. If using stock wheels from the kit, you'll want to concentrate on the outer step. Polish for 1-2 minutes adding polish every 30 seconds. Use a wet paper towel, cotton cloth, or soft bristle toothbrush to clean off any remaining polish on the wheel. Next, inspect the hub making sure it is smooth and shiny. A magnifying glass or [jeweler's loupe](#) is a handy tool for this. If you feel the plastic is not quite shiny enough, repeat the polishing steps, but do so in 30-second intervals.



Stock Wheel

Modified Wheel



Polish the outer hubs



Unpolished

Polished

Stock Wheel



Modified Wheel

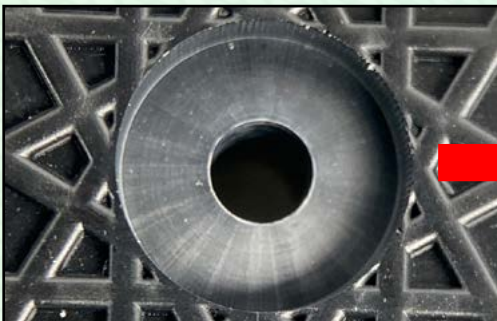

STEP 6: Remove the wheel from the drill. It is now time to polish the bore. A Target® brand cotton swab stalk works for this step. Or, bore polishing tools are available in the wheel [polishing kit](#) and are the **preferred method of professional league racers**. If using the swab stalk, ensure the seam on the stalk is oriented so it runs with the direction of rotation when spinning. Apply polish to the swab stalk or polishing implement from the kit. Spin the drill **as slow as it will go**.



PRO TIP FROM JBD Racing:

When polishing the bores, it is IMPORTANT to run the drill SLOWLY. Too much speed will enlarge or deform the bore, making the car more likely to wiggle and significantly affect performance.



Insert into the wheel from the front and move the wheel forward and back slowly for 15-20 seconds. Remove the wheel, add more polish, flip the wheel and polish the bore for another 15-20 seconds. Rinse the bore in a sink with warm water. Inspect the bore making sure it is smooth and shiny. A magnifying glass or [jeweler's loupe](#) is a handy tool for this. Hold the wheel toward a light so you can see in the bore. If you feel the plastic is not quite shiny enough, repeat the polishing steps, but do so in 10-second intervals. Remember, you want to **spin the drill slowly** when polishing the bores.

Unpolished



Polished



Once you have polished all critical surfaces, soak the wheels in a mixture of warm water and dish soap for 5 minutes. Soaking the wheels will help remove any residue from the polish. Next, **rinse the wheels thoroughly to remove all traces of the soap**.



WHEEL PREP KIT



JEWELER'S LOUPE



Waxing/Sealing

After polishing and cleaning the wheels, it is time to seal the polished surfaces. Synthetic car wax will work, though there are [sealer/wax](#) blends formulated and tested specifically for this purpose, and they are the **preferred choice by league racers**.

Using a cotton swab or applicator from the kit, apply wax to each polished surface, **excluding the treads**. Use the applicator from the [kit](#) or a pipe cleaner for the bore. If using a pipe cleaner, be careful when inserting it into the wheel, so the metal wire does not scratch the bore. Allow the wax/sealer to dry, and then buff off using a microfiber cloth or cotton swab. For the bore, use a new pipe cleaner to buff, or if purchasing the [kit](#), there is a special tool and technique that does an excellent job of buffing the bore and is a step where younger members of the Race Team can fully participate! Make sure to remove any excess wax/sealer. If sealer builds up in the wheel spokes, use a soft bristle toothbrush (dry, no water) to clean the wheel once the wax has cured. Multiple coats of wax (2-4) can help add additional speed!

**WHEEL PREP KIT**

If running a rail riding setup with a raised front wheel, you do not need to polish and wax all of the surfaces of the raised wheel. Instead, prepare only the tread and tread edge.

Do a final inspection of the wheels for any polish/wax residue or lint from the polishing cloth, cotton swabs, or pipe cleaners. Any foreign material trapped on the polished surfaces can reduce speed.



PRO TIP FROM **Mojo Racing**:

Be careful when handling the wheels, especially once they're polished and sealed/waxed. They can be slippery, and dropping them on the floor can very easily lead to a chipped edge and slower speed! When working on the wheels, lay a towel on the work surface so a dropped wheel won't roll off the table!



Axles

As mentioned at the beginning of the last chapter, wheels and axles are where most of the speed lies in Pinewood Derby® cars. Axles lead to huge speed increases if prepared correctly or the possibility for significant instability and a decrease in speed if prepared incorrectly.

The axles in BSA Pinewood Derby® kits will need a fair amount of work to reach their full speed potential. Therefore, use [stainless steel axles](#) if your rules allow them. They offer many advantages over stock axles. They are straighter, have a larger diameter (therefore more stable), can be polished to a much smoother finish (less friction), and many are grooved to minimize the contact area with the wheel bore. Stainless steel axles are faster than stock axles and, as a result, **are the preferred choice of Professional League Racers!**



Stock BSA Axle



Turbo Stainless Steel Axle

When preparing both types of axles (stock and stainless steel), the goal is to sand/polish the contact surfaces **as smooth as possible while minimizing the amount of material removed.**

This chapter will focus primarily on the steps needed to **prepare stock BSA axles.** However, the preparation process for stainless steel axles is similar. The differences in the preparation process are mentioned later in this chapter.

One of the most apparent issues with the stock axles is that many are not straight. There are tools available on the market to straighten the axles. However, purchasing extra [stock axles](#) and picking the straightest ones for your car is often more economically feasible and much quicker. To check the axles, insert them in a drill and spin slowly to see if they wobble. Choose the straightest ones!



STOCK BSA AXLES

To maximize axle speed you will need a few supplies and tools:

- Handheld power drill
- A small file
- Sand paper, grits from 400 - 5k
- Craft (Popsicle™) sticks
- Metal polish
- Microfiber or cotton cloth
- Bowl of water
- Paper towels
- Isopropyl alcohol
- Hacksaw (if rail riding/running)

Optionally there are [kits](#) designed explicitly for this purpose and contain nearly everything you need to create **professional, league-quality axles!**

Let's take a closer look at the stock axles:

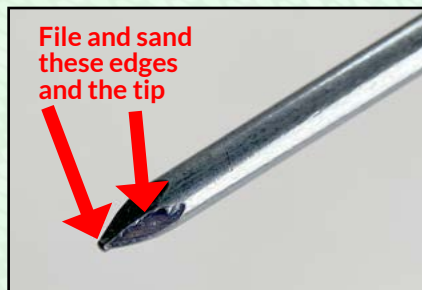

Removing the crimp marks on the axle shaft will significantly reduce the diameter of the axle. Crimp mark removal gives the wheel more room to move on the axle, making it more likely the wheel will vibrate, causing the car to wiggle. An unstable, wiggling car is slow.



AXLE PREP KIT

[Click here to watch how wiggling kills speed!](#)



STEP 1: If building a rail rider/runner car (discussed in other chapters of this book), it is a good idea to cut a slot in the axle head. Once installed in the car, you can turn the axles with a [small screwdriver](#). Slotting the axle head is accomplished by clamping the axle between two pieces of wood (so as not to mar the axle surface) and carefully cutting the slot with a hacksaw. Cutting the slot can be tedious; therefore, a [tool](#) is available that makes cutting the axle slot more manageable.

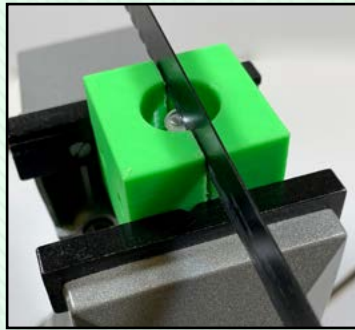

MINI SLOTTED SCREWDRIVER



AXLE GROOVE TOOL

STEP 2: The tip and the sharp edges near the tip of the axle need to be filed and sanded. Otherwise, you **risk damage to the wheel bore** when inserting an axle. Use the small file to bring these edges



down, and then finish with 400 and 800-grit sandpaper. The [axle prep kit](#) contains a special tool to insert the axle into a drill. Otherwise, you'll need to complete this step by hand. There

is no need to go with the higher grit papers or the metal polish, as the goal is to remove the sharp edges so they won't scratch the wheel bore.



AXLE PREP KIT



PRO TIP FROM **Reece Racing**:

If you are building a rail rider/runner car and have cut slots in the axle head, you will want to polish both the sides of the axle head and the top to eliminate the burs created by cutting the groove. Otherwise, the rough slots will pull pieces of lint from your polish cloth that could later become trapped in the wheel bore, slowing the car.

STEP 3: Insert the axle into the drill. The flashing or burs under the axle head must be removed. Using the drill to hold the axle, use the small [file](#) to scrape away the flashing. Do so while the **drill is NOT**



running. You can put the axle head against a table or block of wood and file the burrs off. Inspect the axle head closely ([magnification](#) helps a great deal). Take note of the size and direction of the scratch marks left by the file. Next, dip a strip of 400-grit sandpaper in the bowl of water. Using a craft stick as a backing for the paper, run the drill and sand **underneath the axle head ONLY.** For Race Teams with younger members, place the drill on a table and have them operate while the adult team member sands the axle head. For older Race Teams, you can do the opposite.

Filing the flashing/burs will leave the underside of the axle head quite rough. You'll want to sand with the 400-grit paper for 1 minute (target 600 RPM). Dip the sandpaper in the water bowl at regular intervals. The water keeps the axle from becoming too hot and washes away loose sandpaper and axle material. If cutting a slot in the top of the axle head for a rail riding/running car, sand the sides and top of the axle head during this process to remove any burrs from cutting the slot (30 seconds should suffice). Next, inspect underneath the axle head. **The goal is to remove all the gouges/scratches left by the filing process.** After the 400-grit paper, move to the 800-grit paper and repeat the process. Sand the underside of the axle head for 1 minute to remove all the scratches left by the 400-grit paper.

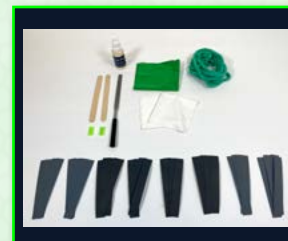

AXLE PREP KIT



JEWELER'S LOUPE

STEP 4: It is time to include the axle shaft in the sanding process. As mentioned before, the goal is to remove as little material as possible, resulting in a smooth axle. On a properly aligned car (see [Alignment](#) chapter), the **rear wheels are riding against the heads of the axles**, so take additional care to sand/polish the underneath of the axle heads until they are extra smooth and shiny!

Keeping the sandpaper wet, utilizing medium pressure, and targeting an RPM of approximately 600, do the following three steps with each grit of sandpaper:



Sand the shaft



Sand under the head



Sand sides and top of head

Use the following as a guide:

- 1000-grit paper, 10-20 seconds on shaft, 60 seconds under axle head, 20 seconds on side and top of axle head
- 1500-grit paper, 10-20 seconds on shaft, 60 seconds under axle head, 20 seconds on side and top of axle head
- 2000-grit paper, 20-30 seconds on shaft, 60 seconds under axle head
- 3000-grit paper, 20-30 seconds on shaft, 60 seconds under axle head
- 5000-grit paper, 30-40 seconds on shaft, 60 seconds under axle head

Remember, the goal is to remove as little material as possible from the shaft, polish a mirror finish underneath the axle head and remove any burrs from cutting the tuning groove on the sides and top of the axle head!

For stainless steel axles, DO NOT sand underneath the axle head with the file, 400 or 800-grit paper. Additionally, skip the 1000 and 1500-grit sandpaper steps as well. Instead, go straight to the 2000-grit steps and proceed from there. However, if you've cut a groove in the top of the axle head for rail riding, you will want to sand the top and sides of the axle head with the 400, 800, 1000, and 1500-grit paper to remove the burrs from cutting the groove.

After completing the sanding process, wash off the axles to remove all loose metal and sandpaper grit, and wipe them thoroughly with a cloth or paper towel. Make sure to clean the tuning groove as well.

STEP 5: Insert the axle back into the drill. Apply metal polish to a microfiber or cotton cloth. Polish the shaft and underneath the axle head for 60 seconds each. **STOP BE CAREFUL; the cloth can entangle the axle and pull fingers in with it. Cutting the microfiber or cotton cloth into smaller pieces helps prevent this.**

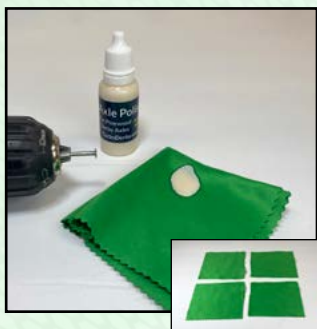

Wash the axles thoroughly with water, and wipe with a cloth or cotton towel. Then soak for 5-10 minutes in either isopropyl alcohol or ammonia-free glass cleaner. Inspect them under [magnification](#) to ensure there is no residue from the polishing process or lint on the axles. Be careful not to touch the axles' polished surfaces, wipe them again, and put them away in a clean, safe place.



PRO TIP FROM HurriCrane Racing:

Coffee filters are an excellent lint-free option for cleaning/wiping axles!



Optional if using graphite as your lubricant: Lightly spray the axles with Lemon Pledge™ Furniture polish. Allow to dry, and put them away.

Optional if using oil: Lightly spray the axles with Dupont® Chain Saver™ or Jig-a-Loo™ lubricant. Allow to dry, and put them away.



Preparing the axle for rail riding

With a rail riding setup, you will need to either drill the steer into the car body or bend one of the front axles. A [drill jig](#) designed for this purpose can be used for drilling steer into the car. A purpose-made drill jig is the method you'll want to use if your race rules prohibit bending axles.

If going with a bent axle for steer (make sure to bend after polishing), here are three different options for bending the axle:

OPTION 1: The bend point on an axle should be about .325-.375" from the bottom of the axle head. Mark the bend point on the axle and clamp it in a bench vise. Use two blocks of wood to prevent damage to the axle. With the mark barely showing above the blocks, place a thin (.25" or so) piece of wood under the axle head and gently tap with a hammer until the axle is bent to the desired amount.

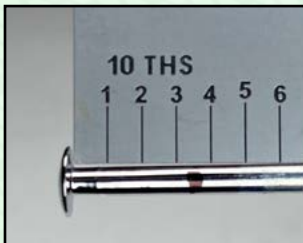

TURBO JIG HYBRID

The bend point of the axle must clear the rear of the wheel bore.



OPTION 2: Place the axle in a power drill or drill press. With the axle spinning, cut a small slot (known as a bending groove) in the axle at the desired bend point using a rotary tool (Dremel®) cutting disc or hacksaw blade. Place the disc or blade on a block of wood at the correct height and push into the spinning axle to cut the groove. Clamp the axle in a bench vise between two blocks of wood with the groove barely exposed. Place the head of a flat-tipped screwdriver in the groove, and tap with a hammer until the axle is bent the desired amount.

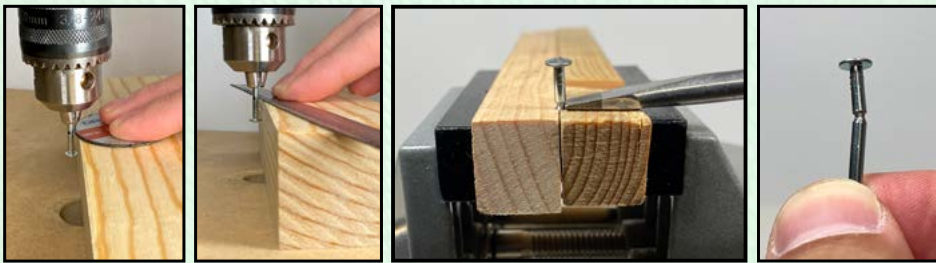

OPTION 3: The preferred method for league racers is to use a [tool](#) designed specifically for this purpose.



*Bend amount
can be
set precisely*

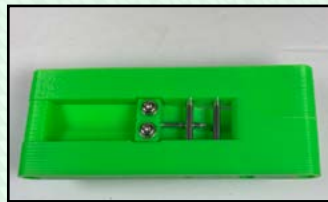

*Quick and
easy to use*



*Precise and
consistent
results*

You will want to bend your front axle a **PRECISE AMOUNT** for maximum speed, ensuring the car is level front to back when racing. See the chapter on [Alignment](#) for more info!



PRO TIP FROM JBD Racing:

Do **NOT** bend the axles for the rear wheels; it is much better to drill the rear holes at an angle (3 degrees of camber) using a drill jig.

Weighting

Along with wheels and axles, weighting is one of the primary areas of speed. The proper placement of weight will maximize the potential energy of your Pinewood Derby® car.

Generally, **what you use as weight matters LESS than where you put the weight.** Scout Race Teams may have limitations on the weights they can obtain. Therefore, the racer can use almost anything;



coins, batteries, bolts, washers, etc., are all excellent options. Please note the Cub Scouts discourage the use of lead over safety concerns. Most craft stores will have inexpensive weights available. However, if maximizing speed is your goal, you will want to invest in tungsten. Tungsten is about

1.7 times the density of lead and is available in 0.25-inch cubes, making them ideal for weighting and balancing fast Pinewood Derby® cars. The cubes can be easily removed and used again in future cars! Tungsten cubes are available [here](#). Use [tungsten putty](#) to fine-tune the car's weight as close as possible without going over!



TUNGSTEN WEIGHT

There are two primary goals when weighting a car:

1. Get as close to the allowed maximum weight (typically 5.0 ounces or 141.75 grams) without going over.
2. Get as much weight as possible, as far back in the body as possible, **while remaining stable.**



TUNGSTEN PUTTY



PRO TIP FROM *Castoro Racing*:

A car that weighs 5.044 ounces (143 grams) will register as 5.0 on a scale that weighs to only a tenth of an ounce. Use this to maximize your potential energy if your official scale only measures to one decimal place!

Why does the weight need to be in the rear of the car? To illustrate, let's look at a car with weight in two different locations; all of the **weight in the back** and all of the **weight in the front**.

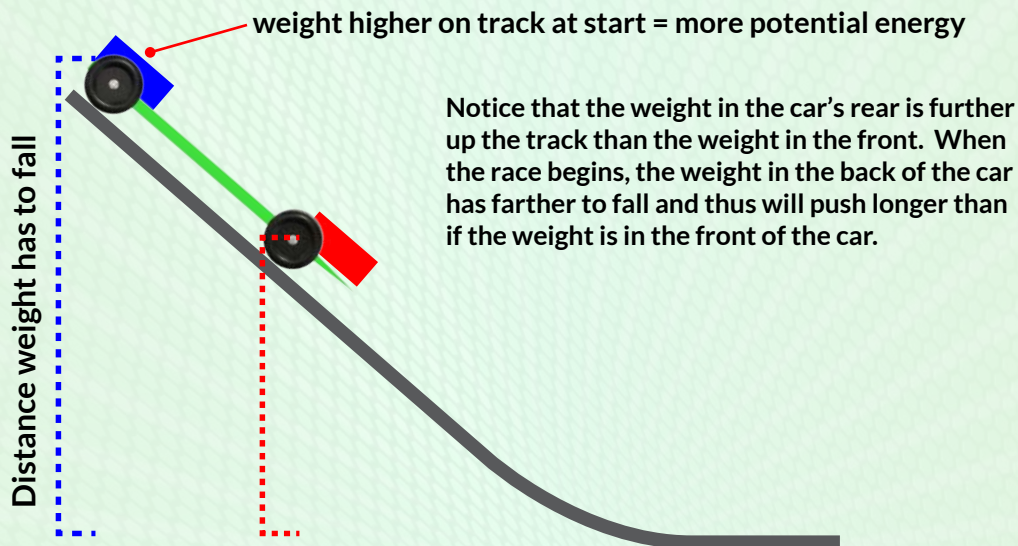

There is a point on the track where the car transitions from being on the hill to running on the flat part of the track.

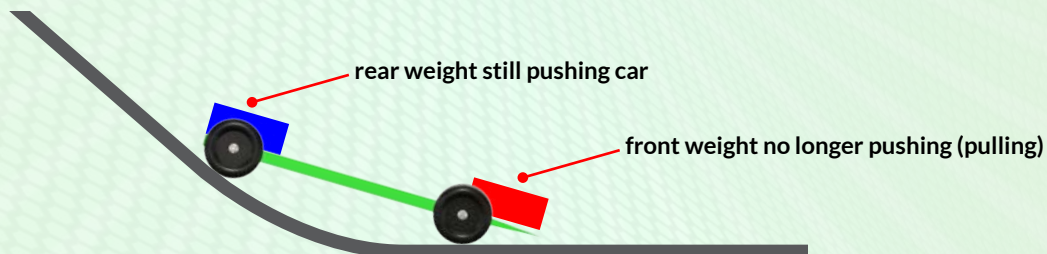

Notice the **rear weight** is still on the hill and falling, pushing the car. The **front weight** on the flat part of the track is no longer falling, therefore no longer pushing (or, in this case, pulling) the car. The extra push made by the **rear weight** significantly affects the car's speed once it is on the flat portion of the track (see video)! →

Click here to watch a properly weighted car pull away from the competition on the flat portion of the track!

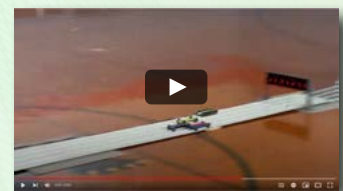

As you move weight toward the back of the car, you increase the load born by the rear wheels and decrease the load handled by the front. There is a point where there can be enough weight in the rear to raise the front wheels off the track, or at least make it so there is not enough downforce on the front to keep the car going straight. This imbalance leads to an unstable car that will wiggle or, in extreme cases, jump off the track.

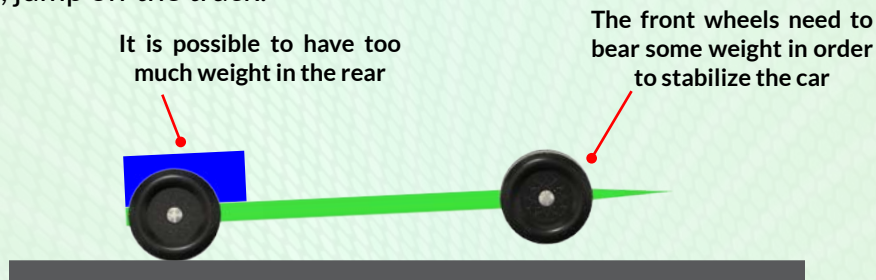

Weight balance and distribution

A balance must be struck between maximizing weight in the rear and keeping the car stable as it races down the track. Two methods are used to balance and distribute the weight in a Pinewood Derby® car.

METHOD 1: Traditional

Traditionally, weighting is accomplished by adjusting the car's center of gravity (COG) by moving the weight forward and backward while targeting a specific balance point.

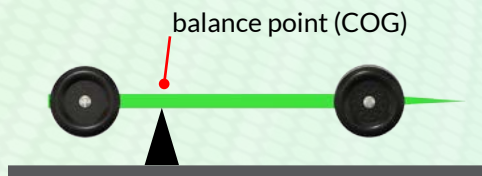

The balance point is measured as a given distance in front of the rear axles (i.e. 1 inch).



A ruler or other straight edge makes a good tool to help fine-tune the COG.

Here are general guidelines for balancing cars using this method:

- For smooth tracks, set the balance point at 0.75 to 1.0 inch in front of the rear axle
- For rough tracks, target 1.0 to 1.50 inches in front of the rear axle

Keep in mind **these are just guidelines**; you may be able to (or need to) go outside these parameters for your car.



PRO TIP FROM *DWS Racing*:

A car with the COG further back has greater potential for more speed but becomes increasingly difficult to achieve stability. Therefore, if you cannot test on a track, it is best to be cautious and set the COG at least 1 to 1½ inches in front of the rear axle.

METHOD 2: Pro

Professional league racers are not concerned with only the COG of the car from front to back but also the weight distribution from side to side. Therefore, they use a different method to weight their cars. Rather than targeting a specific balance point, they look at the load carried by each wheel.

Traditionally professional league racers have used three scales to determine their weight balance. Each of the three wheels that support the car's weight is placed on its own scale.



Weight is moved around the body to arrive at the target weight distribution for each wheel. The racer's goal is to find the amount of weight on the front wheel that results in a stable car and maximizes potential energy.

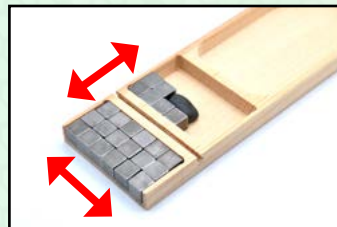

Three scales are not necessary to use this method; here is an [option](#) that allows the Race Team to **accomplish the same using only one scale!**



Here are target values for weight on the front wheel. Many factors should be considered when weighting the car, including track conditions, steer amount, design of car body, etc.

Rough wood or metal track	→	19-21g (0.67-0.74oz) on front wheel
Decent metal track (most Scout tracks)	→	16-18g (0.56-0.63oz) on front wheel
Smooth metal track (some Scout tracks)	→	13-15g (0.46-0.53oz) on front wheel

The weight distribution on the rear wheels is dependent on the contour of the track:

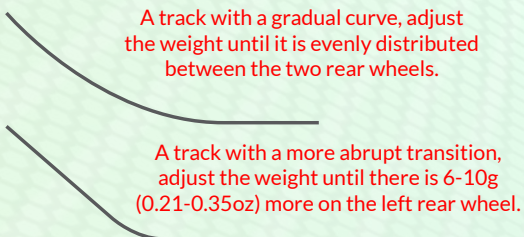

Once the correct weight distribution is determined, the weights can be affixed to the car using double-sided tape and covered with foil tape.



PRO TIP FROM HurriCrane Racing:

You can put less weight on the front wheel for tracks with a gradual transition from the hill to the flat.

Alignment

These days with the popularity of Pinewood Derby® racing and the information available on the internet, most racers in competitive Scout races already know the importance of wheel and axle preparation along with proper weight distribution. Therefore, to finish first in these competitive races, the Race Team needs to **also focus on both Alignment and Aerodynamics** (discussed in the next chapter).

Alignment refers to the arrangement of the wheels and axles in the car body in relation to each other and the body itself. Three areas on a Pinewood Derby® car must be aligned; failure to do so leaves speed on the track!

This chapter covers Alignment in detail; however, an [animated video](#) that presents the same information is available here: 

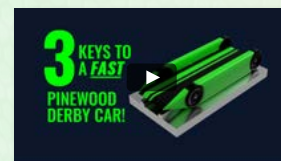

Key Alignment #1 - Rear Wheels

The rear wheels should be set at a 3-degree angle (camber). This angle reduces friction as only a tiny portion of the wheel makes contact with the track. Plus, the angle makes the wheels migrate outward on the axle, rubbing against the axle head rather than the higher friction-prone body. Additionally, the wheel riding against the axle head stabilizes the wheel and helps prevent wiggling. The axle holes (and, therefore, the wheels) must be at the same height, and precisely aligned to each other.

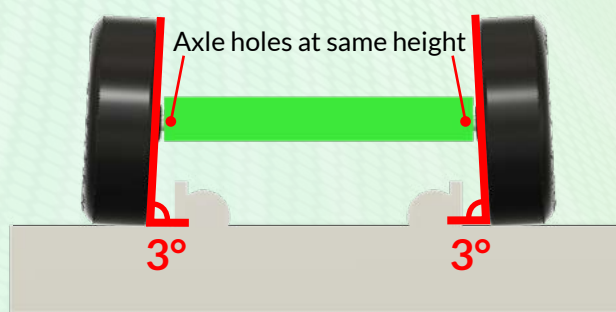

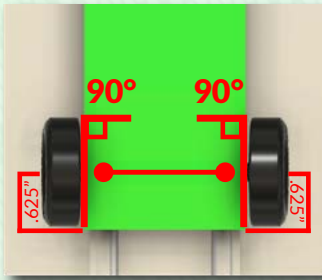

The rear wheels must be parallel to each other and the car body. Additionally, the wheels must be located directly across from one another. Finally, if rules do not prohibit, the rear axle holes should be placed 5/8ths (0.625) of an inch from the car's rear. Moving the rear wheels increases stability and maximizes speed by keeping the rear wheels on the hill of the track longer.

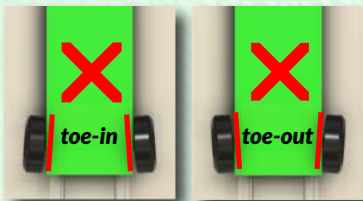

If the wheels are not parallel, they will be in a toe-in or toe-out orientation or a combination of these two. These orientations create a situation where the rear wheels are no longer in sync to steer in the same direction, increasing friction at the axle head and the contact point between the wheels and the track.

Key Alignment #2 - Fore/Aft

To ensure proper alignment, the front and rear of the car need to be level with each other. This is measured by comparing the distance to the track (or another flat surface) at the front and back of the car (providing the bottom of the car is flat).

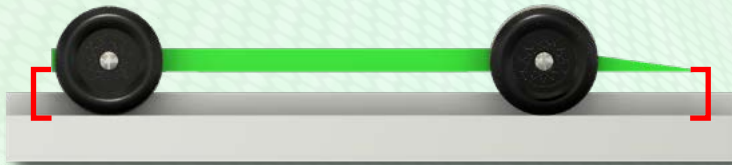

However, running a three-wheel rail riding setup requires a canted front wheel; this tilts the wheel and raises the front of the car.

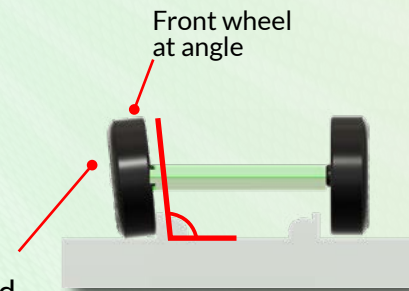

When the front of the car is higher than the rear, it causes a toe-out orientation on the rear wheels, increasing friction and allowing air to enter the back of the wheels, slowing the car.

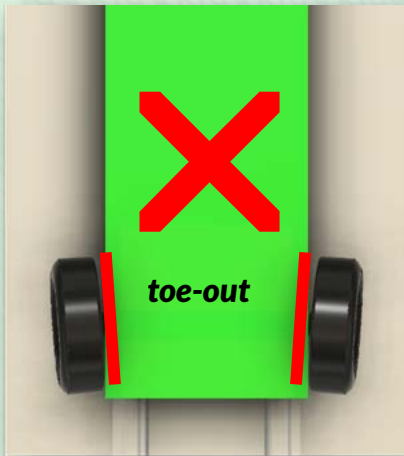

Additionally, the higher front end increases the aerodynamic profile of the car, exposing a larger surface area to the airstream allowing the airflow to push against the bottom of the car, reducing the weight born by the front wheel and therefore decreasing stability.

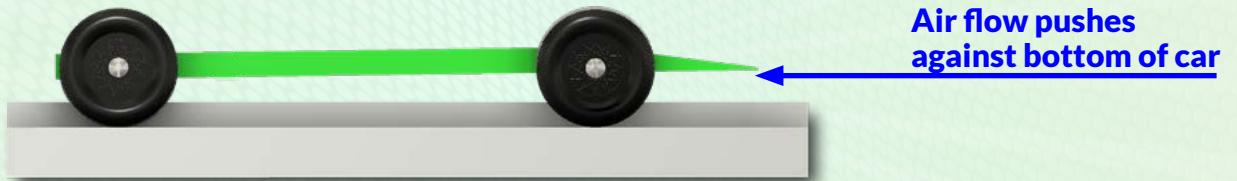

The front axle hole needs to be placed at a **precise amount higher** than the rear axle holes to eliminate the problem of the front of the car being higher than the rear. This placement ensures the rear wheels are not in a toe-in or toe-out position.

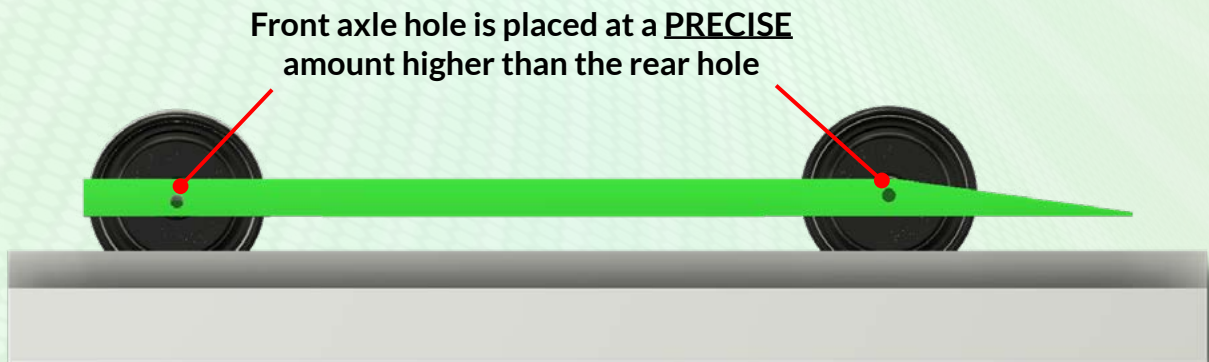

Key Alignment #3 - Side to Side



The front wheel steers into the rail to stabilize the car. A stable car is much faster than one that wiggles. However, if not addressed, the rear wheel on the same side as the steer wheel will also rub the center rail creating additional friction that yields no benefit.

To eliminate this problem, the front of the car body where the wheel is attached is **cut in or notched a precise amount**, enabling the rear wheels to be an equal distance from the center rail. This notch ensures the rear wheels do not rub the center rail or go down the track slightly sideways, increasing friction and slowing the car.

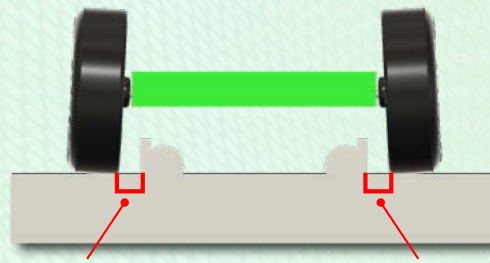

Solving the alignment problem

Properly aligning the car can be difficult. However, Key Alignment #1 (rear wheels) can be solved using one of several drill fixtures on the market.

Key Alignments #2 (fore/aft) and #3 (side to side) are more difficult as **they interact**. First, to level the car front to back, you need to drill the front axle hole a precise amount higher than the rear. Next, however, you must

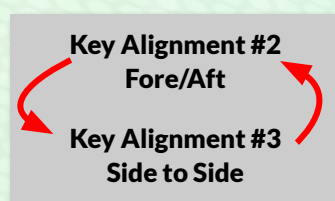

bend the steer axle precisely relative to the hole height to ensure the car is level. Additionally, the amount of the axle bend affects the amount you need to move the steer wheel inward toward the middle of the car by notching the body.

Here are the three elements that must be precisely calculated and implemented in order to solve Alignments # 2 and 3:



Amount of bend in the steer axle

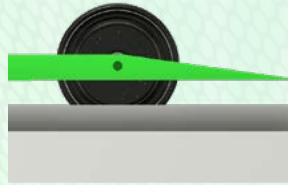

Height of steer axle hole

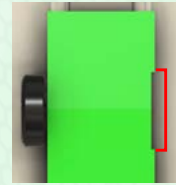

Amount cut or notched into the body at the steer wheel location

Here are target values for these elements:

Steer axle bend amount	Front hole height ABOVE rear holes	Body notch amount
2°	0.017"	0.091"
4°	0.028"	0.074"
6°	0.039"	0.058"
8°	0.049"	0.041"



TURBO JIG



AXLE BENDER

Achieving these parameters using traditional tools can be difficult. However, tools are available that **address each critical area** and ensure the holes are drilled in the correct locations, the body is notched the correct amount, and the axle is bent to the correct angle. They are available [here](#) and [here](#)!



PRO TIP FROM DWS Racing:

It is better to have the front of the car slightly lower than the rear, versus the front slightly higher than the rear. If you cannot precisely set your front hole height to achieve level condition, err on the side of caution, and place it so the front of the car is slightly lower. Lowering the front of the car is accomplished by raising the front hole height (or decreasing the bend in the front axle).

Aerodynamics

Similar to alignment, aerodynamics is another area for speed gains that's not as well known to many Pinewood Derby® racers.

There are two goals regarding aerodynamics:

- Eliminate (or at least minimize) the surfaces that create drag
- Efficiently direct the air around the surfaces that can't be eliminated

The first area to address for aerodynamics is the car body. Consider these two body types:

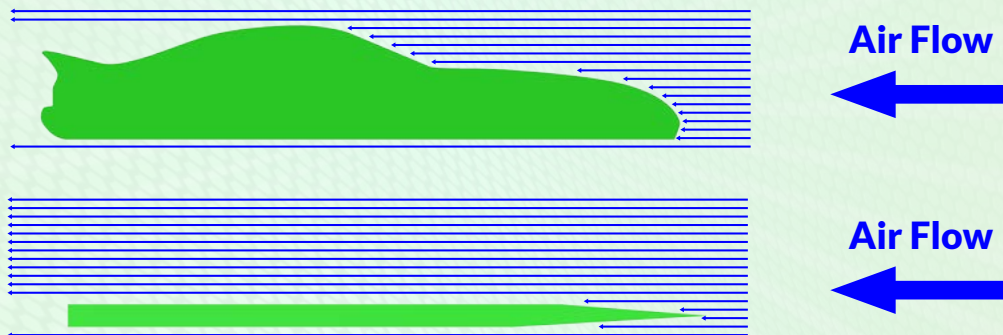

The thin car is more aerodynamically efficient than the first body. As a result, the thin car is the **preferred style for Professional League Racers**.

The car needs to be aerodynamically sound on both the top AND bottom. Any holes or cavities should be covered with vinyl, packing, or foil tape to reduce drag created by air catching in these features.



However, the body is not the only source of drag on a car:

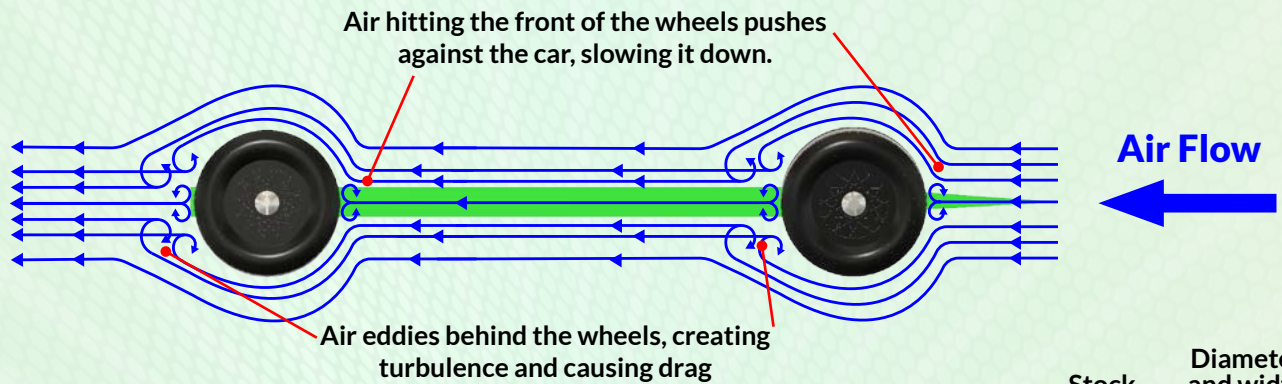

The wheels are a significant source of drag. They present a sizable forward profile and create turbulence (especially behind the wheel), further slowing the car. While the wheels can't be eliminated, if the rules don't prohibit it, they can be shortened (reduction in diameter) and narrowed (reduction in width), which decreases the amount of air they must move. Additionally, there are methods to move the air around the wheels more efficiently.



Reduced wheels available here:



Fenders

Fenders can help efficiently direct the air around the wheels resulting in more speed. There are a few different types of fenders:

Leading Edge Fenders:

These fenders are placed in front of the wheels and help direct air over them, leading to a faster car.

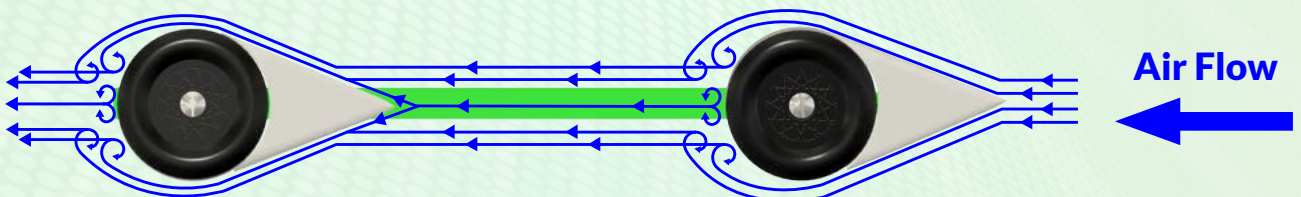

PROS:

- Quick and easy to install
- Faster than a similar car without fenders

CONS:

- Turbulence and drag still behind wheels
- Air moved out of way by front fender must be moved again by rear

Leading and Trailing Edge Fenders:

These are the same as the Leading Edge Fenders, with the addition of fenders behind (trailing) the front wheels. These fenders help direct the air over the front of the wheels but also eliminate the turbulence behind the front wheels leading to a faster car.

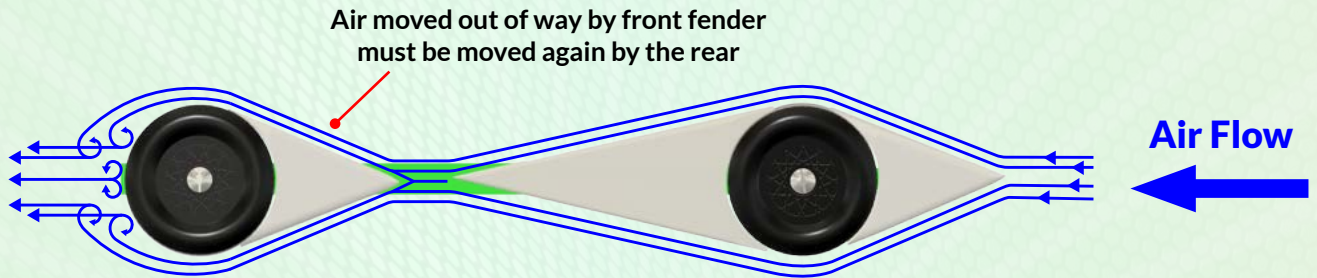
**PROS:**

- Relatively easy to install
- Faster than a similar car with just leading edge fenders.

CONS:

- Trailing edge fender must be shaped properly or can slow the car
- Air moved out of way by front fender must be moved again by rear

Full or Plank Fenders:

The front pieces are the same as the previous fenders; however, the middle fender is a solid piece. These fenders direct the air over the front wheels and straight back to the car's rear. The Full or Plank fender is the fastest design and is the **preferred fender by Professional League Racers!**

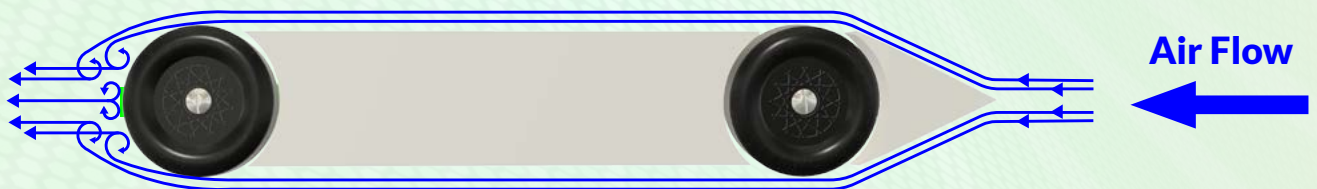
**PROS:**

- Fastest design available
- Does not move the same air out the way twice like other designs

CONS:

- Can be challenging to construct, shape and install. Especially for new racers.
- If not shaped properly middle section can slow the car

Making Fenders

Making fenders is an involved but rewarding process resulting in a faster and more visually appealing (cooler) car! First-time racers or Race Teams with younger members should opt for either the first (Leading Edge) or second (Leading and Trailing Edge) fender designs outlined in the previous section. The Full/Plank fenders can be challenging to construct, and obtaining the proper gap between the fenders and wheels can be difficult.

Traditionally, fenders are constructed from balsa wood. Balsa is available at most craft and hobby stores. However, it can be fragile, so care must be taken when cutting and sanding. Stock BSA wheels are about .425 inches thick, so look for material around 0.5 inches to use for the fenders.

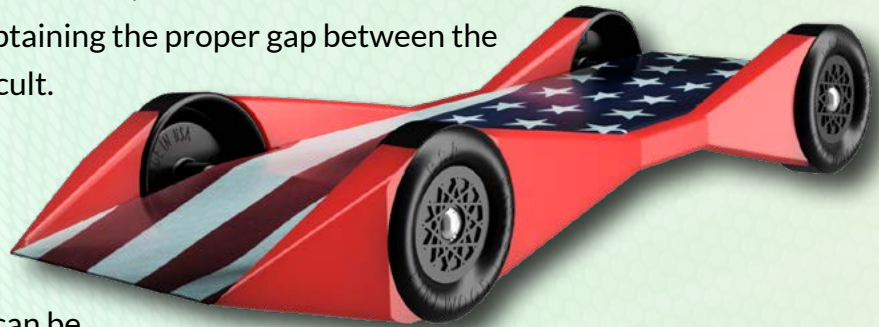

Supplies needed for fender construction:

- Balsa wood
- Coping saw, scroll saw etc.
- Sandpaper (80-220 grit)
- Spare set of wheels and axles, same diameter etc. as race wheels
- Rubber band
- Thick Super Glue™ or epoxy
- Craft knife or razor blade

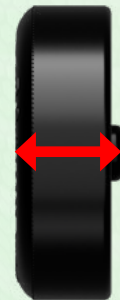

**.425
inches**

Cutting and installing the fenders

STEP 1: Sketch your fender design on your material of choice. Guides or templates can be used to form the basic fender profile (see page 72 for plans). Next, cut out the fenders using a coping saw, band saw, scroll saw, etc. Finally, it's a good idea to sand the wheel well of each fender before gluing it to the car. A spare wheel can be used to ensure the well shape is maintained!

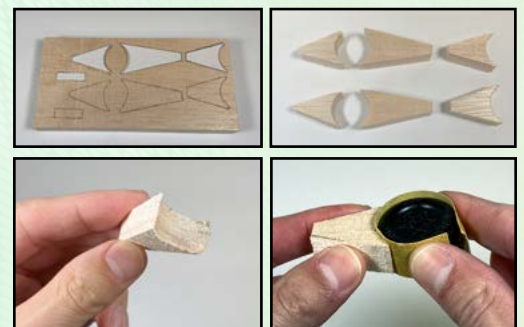

**Use sandpaper around
a spare wheel!**

STEP 2: Insert a spare set of wheels and axles into the car body, as the fender-making process may damage them. If utilizing a rail riding setup with a bent front axle, ensure one of the spare axles is bent the same amount. Temporarily add weight to the car and run it down your tuning board (see the Assembly chapter). You will want to set the steer near where it will be once the car is complete. Four to six inches over



four feet is a good target. You will be using the wheels to help place the fenders on the body; therefore, you want the wheels oriented close to their final race position.

STEP 3: The goal when installing fenders is to get them as close to their respective wheel as possible **WITHOUT** them rubbing the wheel while racing. Therefore, you'll want to err on the side of caution when installing the fenders. Too much gap is preferable to too little, which results in the wheels rubbing.

A rubber band wrapped around the wheel helps obtain good gap spacing. A loose rubber band will give a wider wheel gap; a tightly stretched band will provide less.



Make sure to test fit each fender before you glue it to the body; while doing so, mark the fender's location. Super Glue™ (Cyanoacrylate, or CA) works well due to its quick cure time. Apply glue to the body and then set the fender in place, pushing it against the rubber band/wheel and the body. Wait for the adhesive to set.



Test fit the fender and mark its edge on the body.

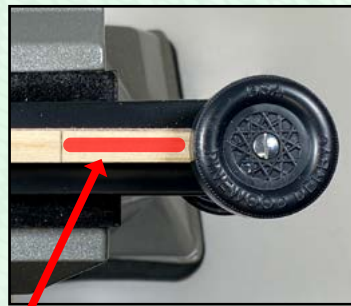

Place glue between the mark and the wheel.



Place the fender on the car and hold in place while pushing against the wheel.

Repeat these steps for the remaining fenders/wheels. Optionally, a centerpiece can be inserted between the trailing and rear fenders. Otherwise, these edges can be sanded flush with the body.

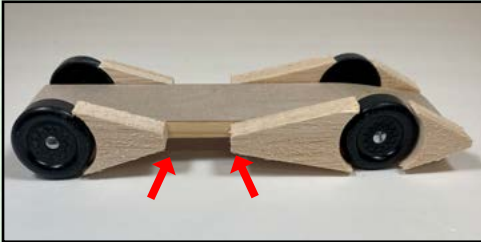

Can leave the center open and angle the fenders edges, sanding them flush to the body.

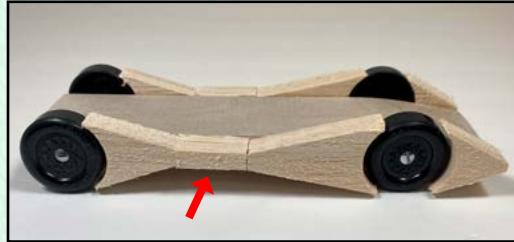

Or can insert a centerpiece.

Shaping the fenders

When shaping the fenders, three areas need to be carefully addressed:

1. Fender bottoms - The bottoms of the fenders need to be shaped or notched so they do not rub the track.

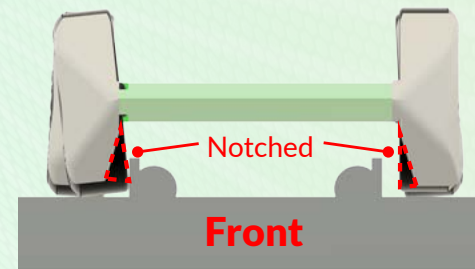
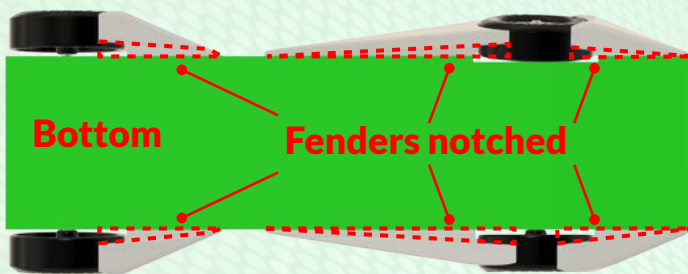

These notches ensure the wheels touch the rails and the fenders do not.

2. Forward profile - The fenders should be shaped to cover the wheels' forward profile. Some clearance on the bottom and top is ok.

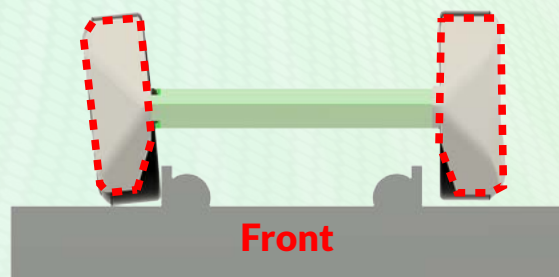

3. Trailing Edge - Great care should be taken when shaping the trailing edge fenders; they need to be more narrow than the wheels, tucking in behind the front wheels to ensure that **no part can stick out past the wheel.**

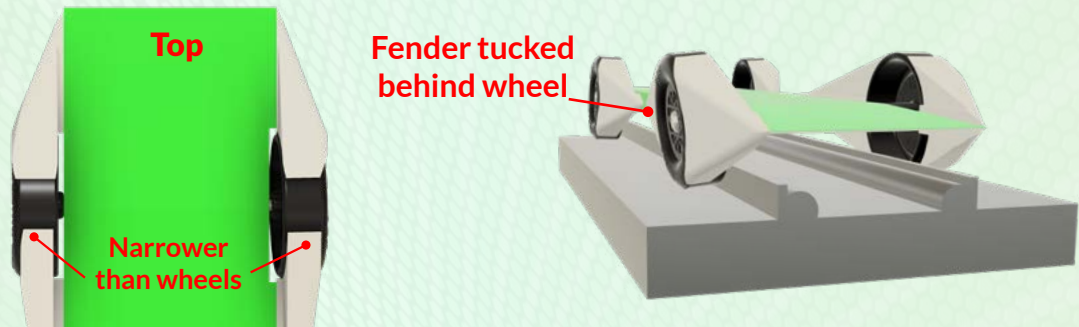

Failure to properly shape the fenders will **result in a significant increase in drag/friction**, negating the benefit of the fenders. In many cases, a poorly done fender car will be **SLOWER** than a similar car with no fenders.

STEP 1: Using a pencil, mark the underside of the fenders (see photo). Cut or carve the excess material using a craft knife or similar. Race Teams may find it better (and safer) to use sandpaper from the start. You'll want to cut further in around the front steer wheel if running a rail rider setup. The front steer wheel is where the fenders will most likely rub the rail. The purpose of cutting around the other fenders is in the event the car wiggles; this will keep the fenders from rubbing, further slowing the car. Cut the notch to the bottom of the car.



Don't cut or carve all the way to your lines, give yourself a buffer so you have room to sand the fenders to their proper size/thickness.

STEP 2: You want the fenders wide enough to cover the wheel's forward profile. Use the edges of the wheels to make your marks and cut the fender down to the body.



STEP 3: For the trailing edge fenders, cut in a bit more behind the front wheel than the front, leading edge fenders. You want to ensure that **NO PART** of the trailing fender can stick out past the wheel.

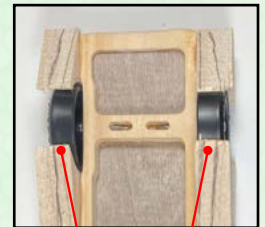

Narrower
than wheels

STEP 4: It is time to sand the fenders to bring them to their final shape. It is a good idea to leave the spare wheels on the car while sanding; this helps ensure you're molding the fenders to the correct form. 80-grit sandpaper can be used; however, be aware that it removes balsa quite quickly, so be careful not to over-sand. Once close to the final shape, start using higher grits (220) of paper to smooth the balsa.



Bottom of fenders notched to
avoid rubbing center rail.

Trailing edge fenders tucked in
behind front wheels.



PRO TIP FROM *Castoro Racing*:

If you accidentally remove too much material, glue a thin piece of balsa in place and sand/blend to shape!

STEP 5: After sanding, inspect the fenders closely. You want to ensure they are not rubbing the wheels in any location. You'll also want to ensure the fenders will not contact the track. The most popular Pinewood Derby track (BestTrack®) has an inner rail 1.625 inches wide and 0.25 inches tall. Mock up a track center rail with these dimensions (or the track you will be racing on) and place your car over it. If running a rail rider setup, place your front steer wheel against it with the rear wheels centered over the mocked-up rail. Again, check to see if the fenders can rub at any location.



PRO TIP FROM DWS Racing:

Hold the car sideways against good lighting where you can see the light between the wheel and fender well. Rotate the wheel with light finger pressure and try to make the wheel contact the wheel well. Use the slop/play between the axle and wheel bore to tilt the wheel in and out while rotating.

STEP 6: To strengthen the fenders rub them with a coat of thin Super Glue™ (CA). Small, inexpensive art brushes™ or rubber-gloved fingers are good options for applying glue. **STOP** The fumes from CA glue can be strong, therefore use in a well-ventilated area. After the glue cures, give them a light sanding with high grit sandpaper.

STEP 7: Some league racers use Sharpie™ pens to color their fenders for ease of use and minimal weight addition. It's easy to apply, especially for younger Team members, and is available in various colors. The fenders can also be painted, though staying away from water-based paints (unless using a sealer first) is recommended, as they can cause the fenders or the car body to swell or warp. Additionally, it is wise to avoid mixing different types of paint.



Due to its challenging nature, fender construction may **not be feasible for all Race Teams**. Alternatively, lightweight plastic [fenders](#) that need **little to no sanding or shaping** are an excellent alternative to making fenders. Some of the [fastest professional racers](#) in the country use these fenders!

Air Shields/Guides:

Another source of drag is air entering the back or inner cavity of the wheels.

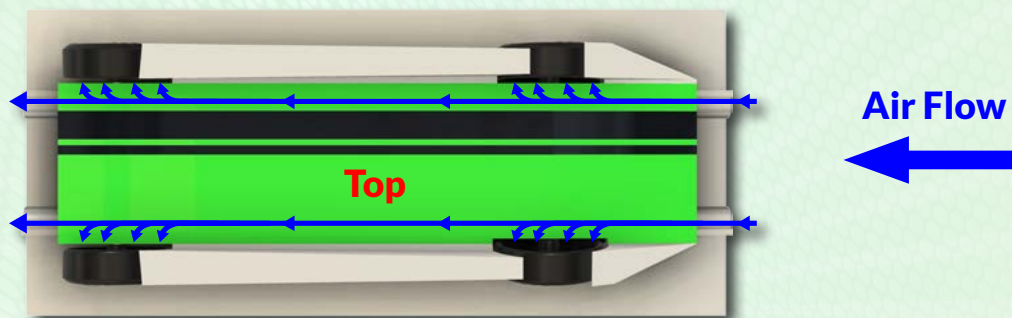

Air redirected by the wheels or fenders can flow into the rear cavity or inside of the wheels. This airflow creates drag and turbulence. However, there is a solution to keep air out of the wheel cavities known as air shields available [here](#).

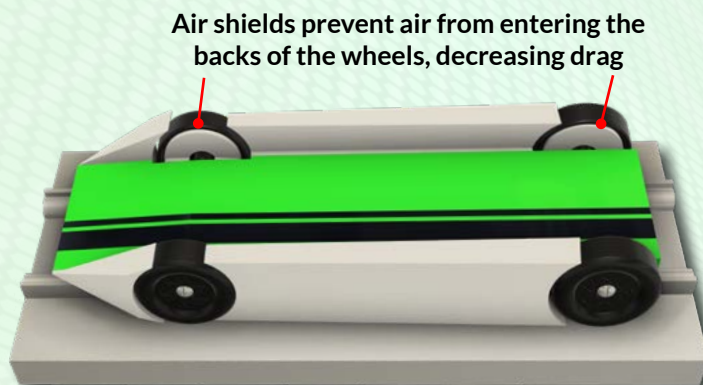

PRO TIP FROM **HurriCrane Racing:**

The higher the level of competition, the more aerodynamics matter!

Body

The body is the foundation of the car and is the place where the Race Team can let their creativity shine! If the Race Team follows most of the techniques in the other chapters of this book, then they will have a fast car regardless of what design they choose for their car body. However, this book examines how professional Pinewood Derby® league racers build their cars. With league racers, speed will always be the primary factor in the shape of the car body. Therefore, aerodynamics is what drives the design.



Not all Race Teams can access the tools required to build a full-on league-style car. Therefore, let's first look at a more accessible option with decent aerodynamic characteristics and can be plenty fast.

The Wedge Car:



The wedge car is relatively easy to make; cut the block from the kit in half diagonally. This is accomplished using one of several types of hand saws (tooth saw, hacksaw, coping saw, etc.) or with power tools such as a bandsaw, jigsaw or scroll saw. Holes are drilled in the car's top, sides, or rear for weights.



A word about the dog bone

A body type that has gained in popularity over the years in Scout and other similar races is the “dog bone” or “hourglass” shaped car. Its main feature is the removal of most of the wood in the center of the car, with only a small rod or thin portion connecting the front and rear of the car where the axles and weight go.

The primary thought process behind this body design is to remove as much wood weight as possible so that weight can be relocated in more advantageous areas (i.e., the rear), maximizing potential energy. While this thinking is sound, and these body types can be fast, they are **NOT as fast as traditional “Thin to Win” pro style cars.**



The reason is mainly due to aerodynamics. Notice the airflow over these two bodies. The **dog bone car must move the same air out of the way twice** while going down the track, a definite disadvantage.

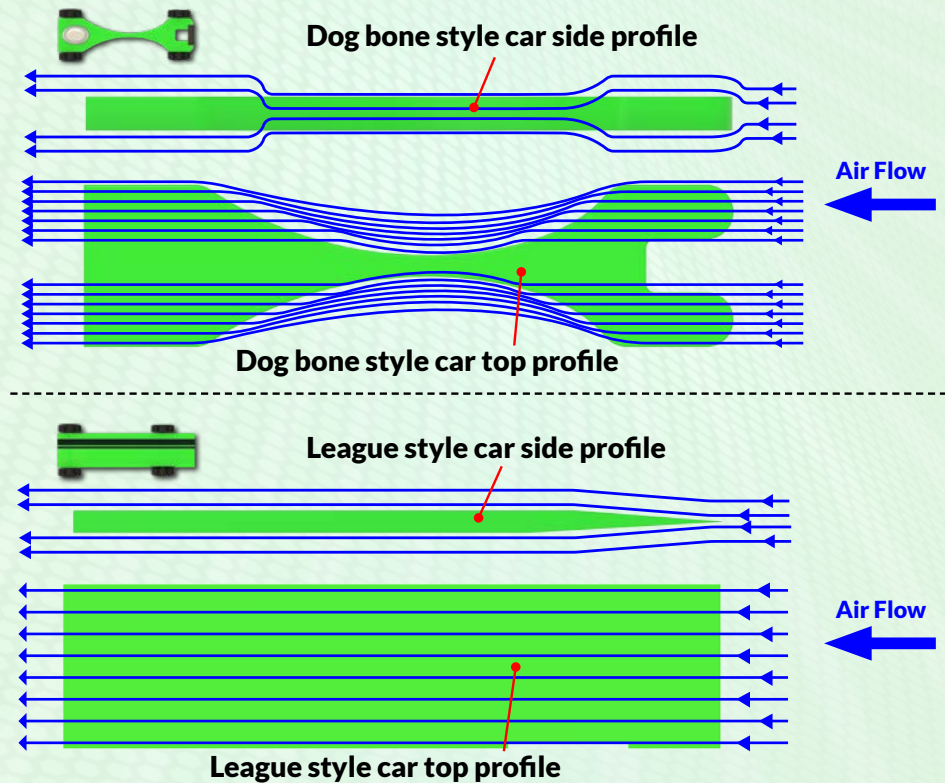

Professional League style car

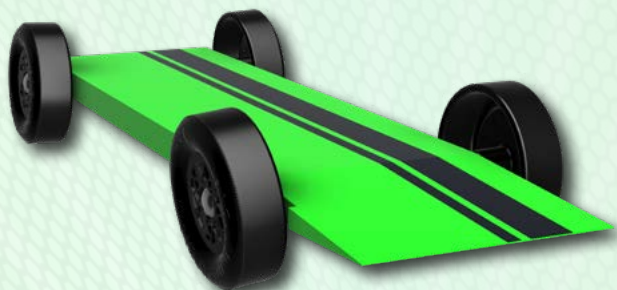

The often repeated mantra among league racers regarding the car body is **“Thin to Win!”** In other words, a thin body is the fastest. As a Pinewood Derby® car speeds down the track, it has to move the air it encounters out of the way. This **pushing of the air creates drag** and slows the car. Therefore, with all other things being equal, a car with the smallest area pushing against the air will be the fastest.



The Pro style car has to push less air out of the way when going down the track.

The other main advantage of a thin car is it helps to maximize potential energy. The slender bodies are much lighter than more traditional designs. By removing most of the wood weight from the car body, the racer can **place the weight in the optimal location** for maximum speed. Weight placement is discussed in more detail in the [Weighting](#) chapter.

While the thin, lower-weight cars are faster, they can be challenging and time-consuming to construct. These cars use special weights that need to be installed in specific locations in the car. Also, additional materials (hobby-grade thin plywood, vinyl, etc.) may be necessary to complete the body.

There are three body types or methods of construction for league-style cars.

Type 1 - Router built with full integrated top



These car bodies are built using a hand router or CNC router to cut out pockets on the bottom of the car for the weights and remove unneeded material from the body. These bodies tend to be .3125 to .375 inches thick.



CNC BSA BODIES

PROS:

- Constructed entirely from the block in the kit, no additional materials needed
- Car can be sanded and painted (or otherwise decorated) just like a more traditional design
- Light and rigid

CONS:

- Requires the use of either a hand router (i.e. trim router) or a CNC router
- It takes patience and care to create this type of body using a hand router.
- Design retains more wood, and therefore more weight, than the other two build options
- Body is slightly thicker than body type 2 below

Guides or templates (see page 73 for plans) can be created to help make this type of body using a hand router. Alternatively, **CNC cut bodies from official BSA blocks** are available [here](#).

Type 2 - Cut through with a separate top (AKA "ladder body")

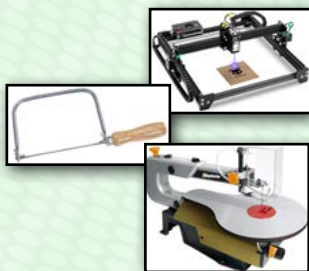

These bodies are built using a coping saw by hand, a scroll saw, or a CNC router/laser. For hand cutting, the design is sketched onto the wood block. A hole is drilled through the block that allows the saw blade to pass through so the builder can cut the interior features of the body. A top needs to be added (glued) to the car. League racers prefer 1/64-inch thick plywood for this purpose.





The plywood is light but very strong and imparts a fair amount of rigidity to the body. League racers will often cover the car with colored vinyl to keep weight to a minimum.

PROS:

- Is the lightest body option, maximizing potential energy
- Is the thinnest body option, maximizing aerodynamics
- Strong and stiff

CONS:

- Takes time and care to cut the body via a coping or scroll saw
- Requires additional material to cover the top

Guides or templates (see page 73 for plans) can be created to help make this type of body. Alternatively, CNC cut bodies from official BSA blocks and 1/64 plywood for the top are available [here](#).

Type 3 - Hybrid cut through/router built

This option has pockets for the weights routed into the body, but all other areas are cut through. League racers will often cover the car with colored vinyl to keep weight to a minimum.



CNC BSA BODIES

PROS:

- Does not need separate material (plywood) for top
- Is lighter than the full routed body

CONS:

- Requires both routing and saw cutting
- Thicker than the cut through with top option

A fourth option employed by some professional racers consists of building the car frame from individual wood pieces, also known as “stick building.” Stick building is an advanced technique that is not practical for most Scout Race Teams and is outside the scope of this book.

**PRO TIP FROM Castoro Racing:**

Do not make the sides of your car body too thin. The body can start to flex, absorbing energy that could otherwise propel the car down the track.

Wheelbase

One of the primary keys to a fast Pinewood Derby® car is getting as much weight as far back in the car body as possible without the car becoming unstable, thereby increasing potential energy. Weighting the car is discussed in more detail in the [Weighting](#) chapter. However, the **car's wheelbase is essential in maximizing potential energy.**

The standard BSA block from the kit has slots for the wheel axles precut in them:



Many races do not require the use of the precut slots. If this is the case with your race, **you will want to move the axle locations** and drill new axle holes, leading to a faster car!

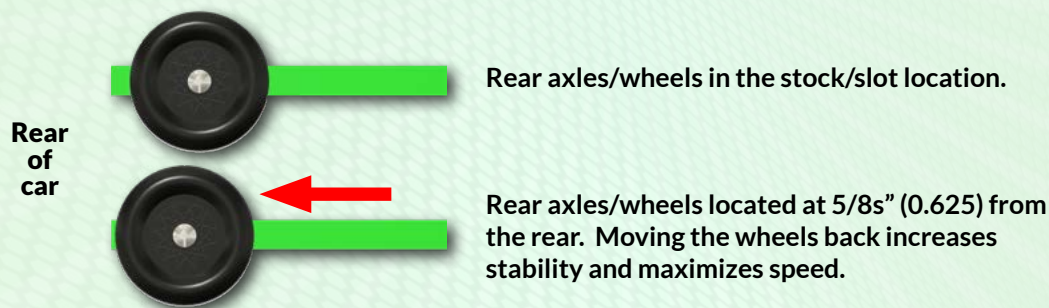

Moving the front wheels forward can help increase the car's stability, allowing more weight to be added to the rear.



However, as with most facets of Pinewood Derby®, there is a **trade-off between speed and stability** regarding wheelbases. The shorter the wheelbase, the more potential there is for speed. However, the shorter wheelbase can also lead to instability, slowing the car.

Trade-off between speed and stability

Consider the two cars below; both are at the same position on the track where it transitions from the hill to the flat. However, notice with the longer wheelbase car, the front wheels are on the flat part of the track and are starting to slow it down. While in the same spot, the shorter wheelbase car still has both the front and rear wheels on the hill and therefore has yet to lose speed. This is a slight difference; however, races can be decided by ten thousandths (0.0001) of a second, so even small amounts can have an impact!

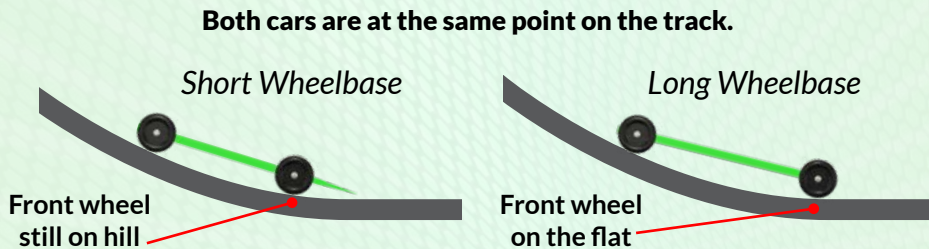

When determining a wheelbase for their car, the Race Team must consider the track condition they'll be racing on. For example, on a smooth aluminum track, a wheelbase of **4.75"** offers a **good balance between speed and stability**. For a rougher track where instability could be a concern, the Race Team might consider going with a 5.0" to 5.25" wheelbase.

New axle holes must be made to move or extend the car's wheelbase. Holes can be drilled using a drill press. However, for maximum speed, it is critically important the **holes are placed in precise locations** relative to one another. The reasons for this are discussed in detail in

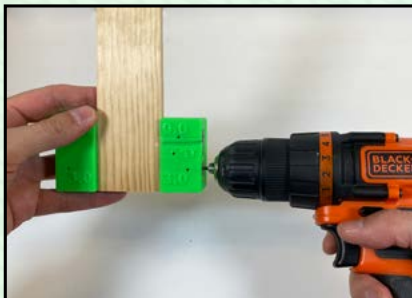

the [Alignment](#) chapter of this book. There are [tools](#) available that have been designed specifically for this purpose. The car body fits into the tool, and the axle holes are drilled in the correct positions.



Body/wheel contact

Before the car's final assembly, a portion of the body must be addressed. A significant friction point on a Pinewood Derby® car is where the wheels can contact the body. This friction point is around the axle slots/holes:

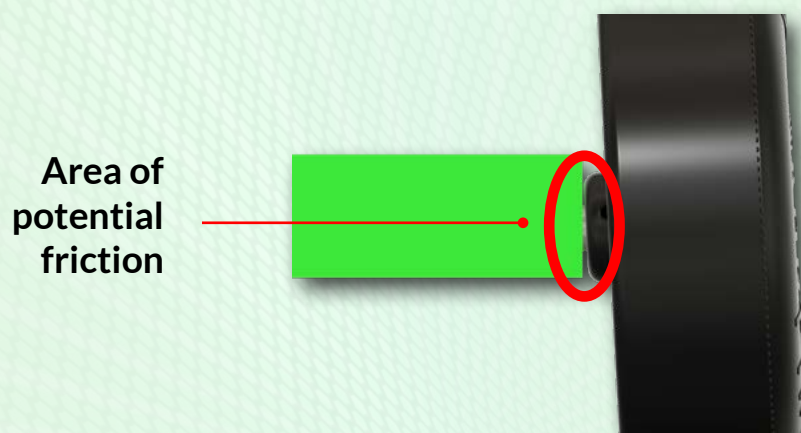

If painting the Pinewood Derby® car body, you will want to mask off or tape over this area. Paint, even when dry, can be quite sticky, so you'll want to **have bare wood around the axles**.



Keep this area bare wood



In the professional leagues, racers will use washers made from Delrin™ or Teflon™ glued to the body to reduce friction. However, washers are prohibited in most Scout races.

Here are three options that will significantly reduce the friction between the wheel and the car body:

OPTION 1: Graphite

If using graphite as your lubricant, rub a generous amount on the bare wood using a cotton swab. You'll want the wood to be as smooth as possible so sanding this area with high-grit paper is beneficial. It's best to sand this area before you paint. When applying the graphite,

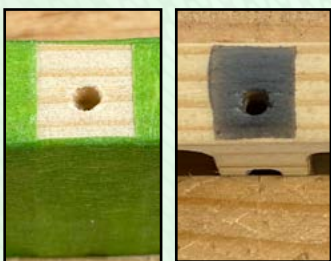

you will want to cover (masking or painter's tape) the painted area around the wood to keep graphite off other parts of the car. Make several graphite applications; you can't do too much.

OPTION 2: Glue

Super Glue™, commonly referred to as CA (Cyanoacrylate) - CA can be used with any lubrication. First, mask off the car, so just the wood around the axle hole shows. Next, apply glue around the hole. CA doesn't take long to dry (cure), and a fluid that dramatically speeds up the curing process, known as "activator", can be used. After the glue cures, sand it with 400-grit sandpaper to level it out. Next, clean off any dust and add another layer of glue. **Repeat this process 2-4 times, sanding with the 400-grit paper once cured.** You may need to remask with tape around the hole, as the sanding of the glue

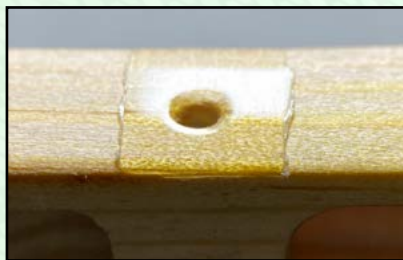

may wear off the tape. Once there is a good layer of glue, sand with increasingly higher grits of sandpaper (i.e., 800, 1000, 1500, 2000, 3000, etc.). Your goal is to create a **very smooth and shiny surface**. Once

done, apply a coat or two of your wheel wax/sealer, making sure to let it haze over, then buff it out. If using graphite as your lubricant, there is an additional step you'll want to perform in this area; however, this is covered in the [Lubrication](#) chapter.

OPTION 3: Teflon™ PTFE (polytetrafluoroethylene) Film

This hyper-slippy [tape/sticker](#) can be attached to the car body with the axle passing through the center.



Lubrication

Lubrication is key to unlocking your car's full potential! Lubricants help minimize friction between the wheels and axles, resulting in a **significant increase in speed**. However, race rules can vary on the use of lubricants, so you'll want to consult yours to ensure what options are allowed.

Lubricants fall into two categories: Dry and Liquid.

Dry - As the name implies, these lubricants contain no liquid and come in several varieties, usually in powdered form. By far, the most common in Pinewood Derby® is graphite. There are different types of graphite used for various purposes. The main difference between them is the purity, flake/particle size and if there are additional additives. While just about any graphite will work as a lubricant, some versions are specially formulated and work best for Pinewood Derby®.

Liquid - There are different liquid lubricants as well. Nyoil™ has been a popular option in years past, as well as Krytox™, produced by DuPont®. There are options preferred by league racers, similar to Krytox™ but with a lower viscosity leading to faster speeds. It is best to stick with a purpose-made oil as those purchased at automotive and hardware stores will be too viscous (thick), resulting in a lack of speed compared to the purpose-made oil lubricants.



TURBO GRAPHITE



TURBO OIL

Do NOT mix oil and graphite; use one or the other.



PRO TIP FROM HurriCrane Racing:

If your rules do not prohibit the use of oil, do so, as it is MUCH faster than powdered lubricants (including graphite). Also, oil is easier and quicker to apply and is not nearly as messy. Additionally, the car can do significantly more runs before losing speed compared to powdered lubricants.

Applying oil

Getting the most out of oil is not as involved as graphite. Methods of oiling the car will vary slightly depending on the type of oil used; unlike graphite, it **IS** possible to over-oil. Using too much can SLOW the car down; therefore, follow the directions supplied with your choice of oil.

Generally, oil application is as follows:

1. Cleanliness is essential when using oil. Any bit of dirt or lint that makes its way into the wheel bore or under the axle head will slow the car. Thoroughly clean the axles and wheels and, if possible, blow them off with compressed air.
2. Insert the axle part way into the wheel bore.
3. Apply a small drop to the axle shaft and a small drop to the axle head. Twist the axle to distribute the oil along the shaft and head. A slight shake will help remove excess oil.
4. Insert the axle into the wheel bore and give the wheel several slow spins with the axle head pointing toward the ground.
5. The axle/wheel is now ready to install on the car.
6. As mentioned before, cleanliness is vital with oil, so once the car is assembled, wipe away any excess oil on the wheels, place the car in a sealable (zipper lock) bag, and store it safely. The sealable bag will ensure no contamination and reduce the potential evaporation of the lubricant.

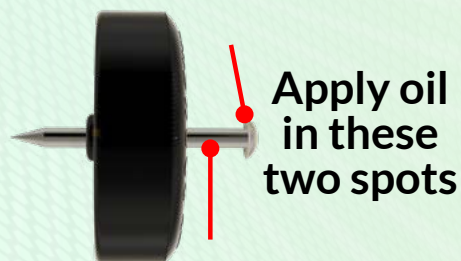

TURBO OIL

Applying graphite

Some first-time racers will apply a couple of puffs of graphite to their car before the race and call it done. While this is certainly preferable to no graphite, it is not optimal. Getting the most out of graphite is a several-step process.



CAUTION: graphite is a very fine substance whose particles can quickly become airborne and cause irritation of the lungs. Use proper care when working with graphite, including adequate ventilation and protective gear.



TURBO GRAPHITE

Known as burnishing, you'll be crushing/embedding graphite into the plastic, creating a thin layer of graphite. Graphite works best when applied in multiple layers, so you'll repeat these steps several times.



PRO TIP FROM *Mojo Racing*:

Graphite can be very messy; put newspaper or another similar cover on your workspace when using it. To remove graphite from the car body, table, and other areas where you don't want it, use isopropyl alcohol or WD40.

Graphite application:

1. **Outer Hub:** Use your preferred method to hold the wheel in a power drill. Sprinkle a cotton swab tip with graphite. Spin the wheel and press the swab into the outer hub. Run the drill for about 1 minute. Apply more graphite to the cotton swab and repeat 3 - 5 times.



2. **Inner Hub:** Flip the wheel and repeat the above steps for the inner hub. If using a rail riding setup, burnish graphite onto the inner edge of the tread on the **front wheels only**. Burnishing graphite on the edge of the rear wheels will foul the actual tread and lead to an unstable car.

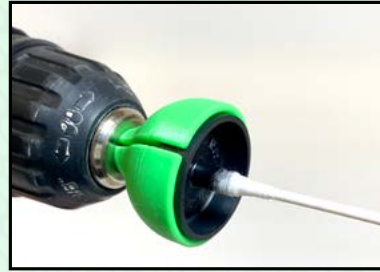

3. **Bore:** Fill the wheel bore with graphite. Insert a polished [pin](#) or polished axle. Gently roll the wheel forward and backward on a towel or similar surface while applying downward pressure on the pin. Do this for a minute or two, and repeat this step 3-5 times.



Burnish the edge on the front wheels only

4. **Body:** As mentioned in the Body section, apply graphite to the car body at the axle holes using a cotton swab.

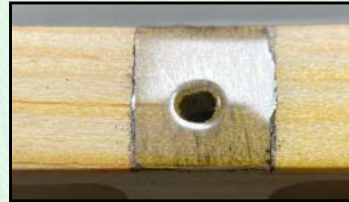

5. **OPTIONAL:** For extra speed, burnish graphite onto the axles as well. Sprinkle graphite onto a soft cloth, insert a polished axle into a drill and turn it slowly while pressing the cloth/graphite to the axle. Do so for 1 minute, 3-5 times.

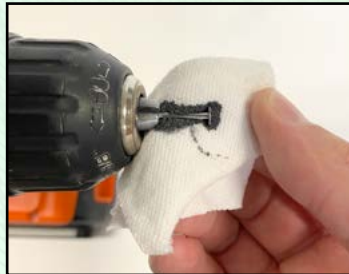

Do **NOT** apply graphite to the tread, use isopropyl alcohol to remove any graphite from the tread

6. **Inspect:** After applying graphite to all areas (wheels, body, axles), inspect and remove any lint left by the cotton swab or cloth.



PRO TIP FROM **JBD Racing:**

For an extra burst of speed, lightly dust the cotton swab/cloth with Lemon Pledge Furniture polish before sprinkling the swab/cloth with graphite. The polish's silicone helps bind the graphite to the wheel and makes a very slippery surface!



After Car Assembly:

Once you have assembled the car, adding graphite to the wheels again is good practice. Place a small amount of graphite on the sides of the axle head. Gently tap the wheel to encourage the graphite to find its



way under the axle head and into the wheel bore. Turn the car so the wheel faces the ground and spin the wheel several times. Repeat this process with the inner hub. Apply graphite and tap the wheel to spread the graphite into the inner hub and between the wheel and the car body. Turn the car so the wheel faces up and spin it several times. A soft bristle paintbrush works well to push graphite under the axle head and onto the inner hub. Add more graphite and repeat.

Graphite will wear and start to lose its effectiveness over several runs. Therefore, always add more graphite after test runs, and if you can re-lubricate during a race, do so!

Storing the car

Once assembly, lubrication, and tuning are complete, it is best to store the car in a zipper-lock-style plastic bag to prevent dust from contaminating the wheel bores and axles. Additionally, place the car body on a block of wood or similar so the wheels do not bear the car's weight. This prevents flat spots from developing on the wheels!



Assembly

Once your wheels, axles, and car body are completed, it's time to put the car together!

Determine your desired weight balance/distribution (see [Weighting](#) chapter). Next, attach the wheels and axles to the car; however, do not insert the axles all the way.

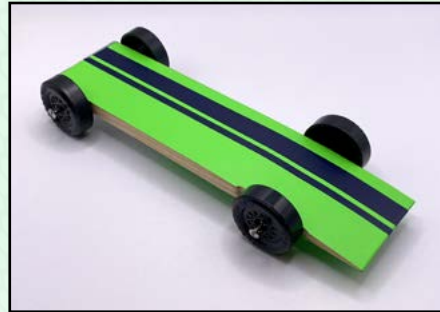

PRO TIP FROM *Reece Racing*:

Use a second or spare set of wheels and axles to work out your weight distribution. This keeps accidental damage to the actual race wheels/axles to a minimum. Also, the axle holes/slots may need to be relaxed a bit and a spare axle is a good choice for this.

Arrange the weight on the car in the approximate final location (easiest to do with a flat/thin car). Place the car on your preferred balance tool (scales or straight edge). Shift the weight until you hit your desired weight distribution/balance point. Affix the weights using two-sided tape or glue. Cover over the weight with foil tape. Cover all holes and pockets in the car that could trap air, slowing it down. Cavities can be covered using packing tape, vinyl, or another similar material.

Placing the car upside down makes it easier to fine-tune weight distribution.



Insert the wheels and axles all the way. For rail riding setups, you will want the right front axle head of the bent axle to point downward.



Setting the Wheel Gaps

When inserting the wheels into the body, you want a small gap between the wheel's inner hub and the body itself. Too much gap and the wheels will move back and forth on the axles, causing the car to wiggle and lose speed. Too little space and the wheel will bind against the body. Set your gap so there is enough room for the wheel to move back and forth slightly on the axle. Four sheets of standard copy paper can be used for setting the gap. Insert the paper between the car body and the inner wheel hub, push the wheel/axle into the body until tight, then remove the paper. Alternatively, a gap tool used by league racers is available [here](#). League racers like small wheel gaps of 0.01 inches or so.



WHEEL GAP TOOL

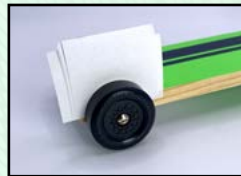
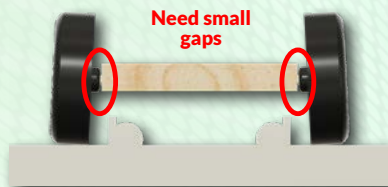

Four sheets of copy paper can be used to set the wheel gap.

Raised Front Wheel

The wheels are a significant source of potential energy drain on a Pinewood Derby® car. Raising the non-steer wheel (typically the front left) so it does not contact the track reduces the amount of energy used to start the wheels spinning.

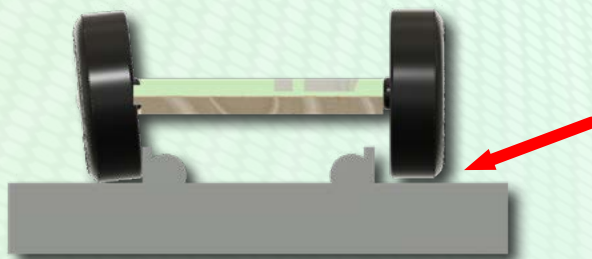

Non-steering front wheel raised or lifted slightly off track.

There are different methods to raise the front wheel:

- The bending of the front steer axle and the tilting of the steering wheel are often enough to lift the non-steer wheel off the track. This is the preferred method for league racers.

- The non-steer wheel axle hole can be drilled slightly higher than the steer wheel axle hole. This is a good option for Race Teams. The standard (smaller) version of the [Turbo Jig](#) has the non-steer front hole set 0.01" higher.
- If bending axles is not prohibited, then the raised wheel axle can be bent and rotated, so the wheel does not contact the track.

When installing the raised wheel, push the axle in tight so the wheel is pinned against the car body. You do not want to risk the wheel spinning, creating vibrations.

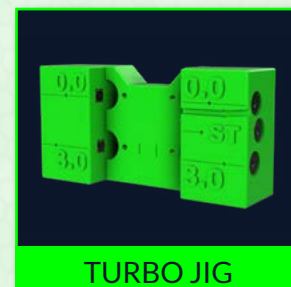

TURBO JIG



PRO TIP FROM *Mojo Racing*:

If you aren't using fenders or air shields and can bend your axles, bend your raised wheel axle. Then turn the axle so the raised wheel is tilted/turned in slightly. This helps to prevent air from entering the rear of the raised wheel, creating drag!



Tuning/setting steer

You'll need to adjust your steer if running a rail rider setup. To do so, you will need a way to measure how much the car steers over a given distance. Any flat surface that is 5-6 feet long and can be slightly elevated at one end and leveled side to side will work. A **board, shelving, coffee table, a full-length mirror**, etc., are good options to use as a tuning board.

Measure two to three inches from the side at both ends (*see graphic on following page*). Put a piece of tape running down the board so it is straight and parallel to the sides. The tape running down the board is your center line. Next, measure 55 inches (48 inches plus 7 inches for the car) from one of the ends and put a piece of tape across the width of the board. Mark the second piece of tape in increments of one inch starting from the longer strip of tape.

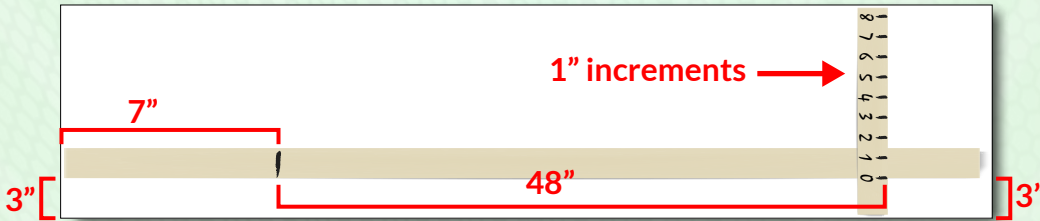

Place something at the end to stop the car. A cushion, pillow etc.

Place the board on a flat surface and **slightly elevate the start end**. You want just enough slope so the car will run down the board slowly but consistently. Check that the board is level side to side and shim as needed to level it. Make sure you have a helper, pillow, blanket, or some way to stop the car when it rolls to the end of the board. Placing your board on the floor helps prevent your new car from rolling off the board and the table!

Place the car at the top of the board, align the outside of the wheels with the tape, and let the car roll down the board.

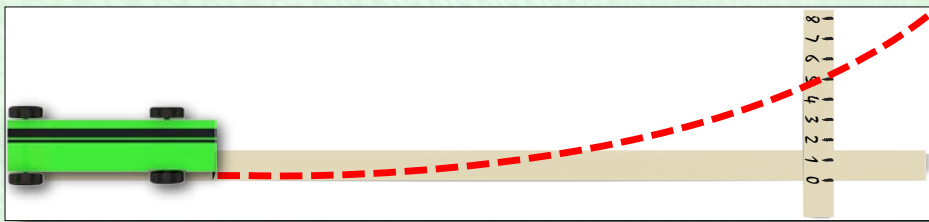

Remember, when installing the front steer wheel (usually the right) you want the bent axle turned so the axle head faces downward.



Using a flathead screwdriver, adjust the steer by turning the axle. Clockwise will turn the car to the right (decreasing steer), and counterclockwise will turn the car to the left (increasing steer). The steer can be very sensitive, so minor adjustments are needed. Make changes until you have the car steering your desired amount. The proper steer amount is usually 4-6 inches.



Setting steer is a balancing act between the amount of steer and the weight on the front wheel. If you have more weight on the front wheel, the car will need less steer; less weight will require more steer.

If you do not have access to a track to tune on, a good car setup would be 16-17 grams (0.56-0.60 oz) on the front wheel and 4-5 inches of steer!



PRO TIP FROM DWS Racing:

It's FAR BETTER to have a little more steer than you think you need than to have too little that results in an unstable car!

Internet: The Wild West of PWD info

The internet contains a vast amount of information about Pinewood Derby®. Unfortunately, there is a lot of good information mixed with questionable. Let's look at a few recommendations that, for whatever reason, have gained traction on the internet but don't necessarily lead to faster cars:

- Tuning the car or "breaking in" the graphite on a treadmill. - Simply put, don't do it! The belt can **damage the relatively fragile wheels**, resulting in a loss of speed. To break in the graphite, spin the wheels by hand or run the car down a track.
- Packing the wheel hubs with a slurry of graphite and isopropyl alcohol. - Once the alcohol evaporates, you're left with dry graphite that will spill out onto your tuning board when adjusting your steer or the track during the car's first heat.
- Quick start bar. - In theory, these make sense. It gets the car rolling before the other cars due to the higher contact point with the starting peg. However, with today's spring-loaded starting gates, the peg slams down much faster than the car can start rolling, negating the quick start bar's advantage. Further, the bar needs an attachment (often electrical tape) to ensure the car triggers the timer correctly. If not perfectly aligned, the attachment will increase drag, and there is no guarantee it will trigger the light sensor at the finish line instead of the actual car body an inch behind it. Additionally, the "dog bone" design usually associated with the quick start bar is not the best aerodynamically.
- Bending the car's rear axles. - The thought process behind bending the rear axles is so the wheels will migrate outward on the axle and ride against the head, reducing friction and stabilizing the wheel. While this is sound logic (and is why league racers drill the rear axle holes at an angle), it is challenging to get them right when bending. Maximizing the car's speed with bent rear axles will be difficult without a track to tune the car on and a lot of patience.



- Polishing/burnishing the entire wheel with graphite. - If you use graphite as your lubricant, you should polish/burnish the wheel hubs and bore with graphite. However, you should not polish the wheel treads (the part that touches the track) themselves. While the shiny, gunmetal gray effect looks cool, graphite on the wheel treads will make them too slippery and lead to an unstable, wiggly car. Ultimately you want the wheel treads to be smooth, not slippery!
- Baking the wood block to remove moisture - Baking the wood block takes time and effort that is better spent elsewhere. After baking, the block will start to absorb moisture again, likely resulting in a warped body, especially if going with a thin league-style car. A warped body will throw off the alignment and slow the car. The risk of warping outweighs the minuscule weight savings.
- The myth that Aerodynamics doesn't matter. - Most of the speed in a PWD car results from properly preparing the wheels, axles, and weight distribution. However, aerodynamics does have an impact and has been thoroughly tested. This fact is proven in practically every professional league race. In classes where aerodynamic additions (thin body, fenders, air shields, etc.) are allowed, any car that runs without these features will almost always finish dead last! **In competitive Scout races, aerodynamics will make a difference.**

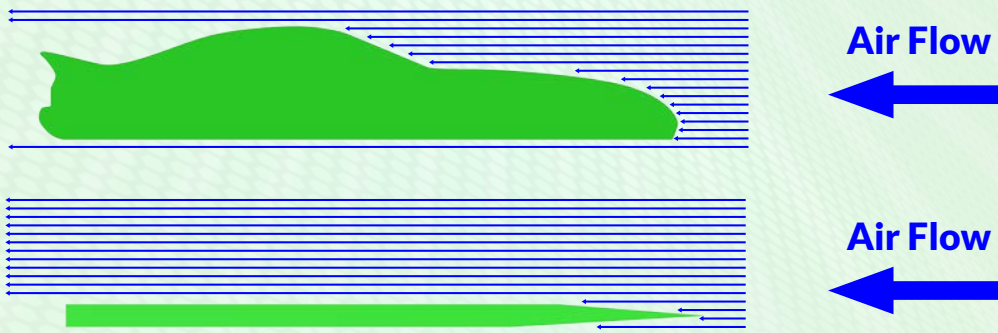

Race Day

Once race day arrives, ensure you are prepared, anything can and will happen!

The Race Team should discuss what to do with their car on arrival before the race. Other teams will likely be running their cars down the track or across the floor. A spontaneous game of smash-up derby might break out among the kid members of different Race Teams. Even **slight damage to a car can affect its speed**, so it's recommended to keep the car in a safe place until check-in. Afterward, keep an eye on your car to prevent any accidental damage by race officials or other Race Teams.



Inspection/Weigh in:

As mentioned previously, you'll want to have your car as close as possible to the allowed weight without going over. The official race scale may read differently than the scale used while constructing the car, be prepared to remove (or add) weight if necessary. Using tungsten putty to fine-tune the car's weight, along with foil tape to hold the weights, makes it easy to adjust the weight if needed.

Make sure you are very familiar with your race rules. Be prepared to advocate for your car if any questions arise during check-in. It is quite possible that the person checking in the cars may not be that familiar with the rules and will be going with what they think is "right" rather than what the rules state. The best strategy **to avoid issues on race day is to clarify any questions** regarding the rules with race officials in advance. However, if there are any areas you think could be open to interpretation and could be used to disqualify your car, **be prepared to make changes**. Bring extra sets of race-ready, unmodified wheels, axles, etc.

Be prepared to make repairs to the car as well. Here is a list of items you should consider bringing to the race:

- Set of race-ready wheels
- Set of race-ready axles
- Extra weight (tungsten putty)
- CA glue (i.e. Super Glue™)
- CA accelerator
- Clear packing tape
- Race-approved lubricant (graphite, oil etc.)
- Craft knife
- Drill
- Double-sided tape
- Pliers

Typically race rules allow a set amount of time to repair a damaged car once the race begins, usually around 5 minutes. Therefore be prepared to move quickly if the need arises!

League Racing

Pinewood Derby® racing can certainly be addictive. If the Race Team finds they want to race more and strive to build faster cars, League Racing is an excellent opportunity to do so. You will be racing against the fastest racers in the country. You will get beat at first, but you will also learn quite a lot!

To learn how to build truly fast cars, you must race against truly fast racers!

Here is the Professional National League:

International Pinewood Derby Association (IPDA): ipda.boards.net



IPDA runs 6-8 races per year with a point system and a Championship at the end of the season. There are trophies and prize money for winners. There are multiple classes with different rules for each. The racer can enter as many cars in whatever category they choose. The racer builds their car(s) and **mails them to the race location**; the race is streamed live on **YouTube**. The cars are sent back to the racer to make any needed adjustments to improve for the next race. The same car can be raced multiple times, even over multiple seasons; building a new car for each race is not required. Experienced racers are always happy to help a new racer improve!

Click below to view a recording of league race:



PRO TIP FROM *Reece Racing*:

League racing is a great way to learn how to build faster cars for Scouts!

Print at 100%, do NOT choose "Fit to Page"

**BSA Stock Block
(4.375" Wheelbase)**

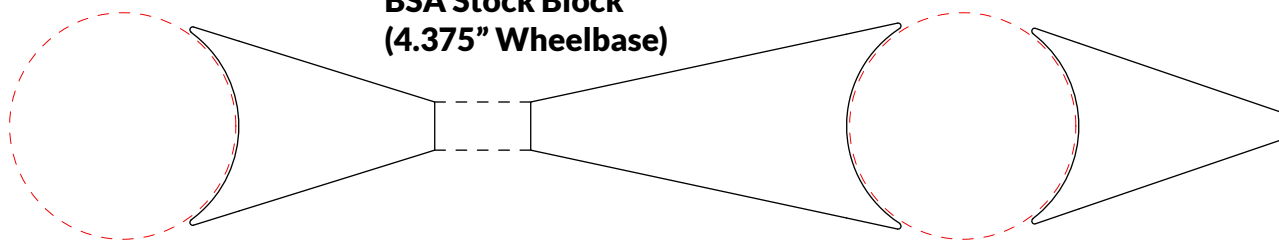

4.50" Wheelbase

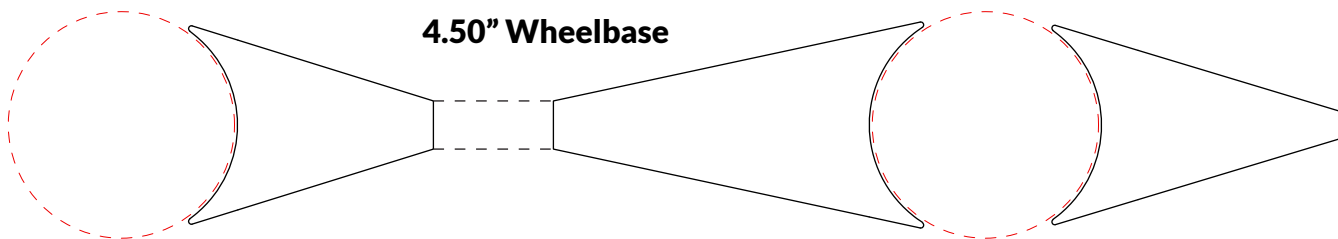

4.75" Wheelbase

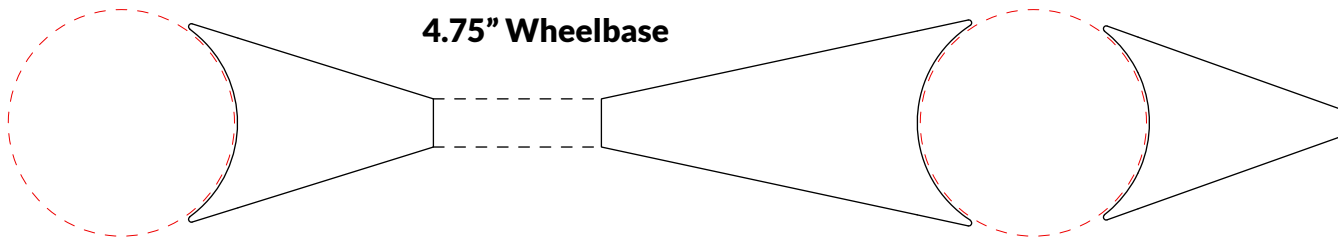

5.00" Wheelbase

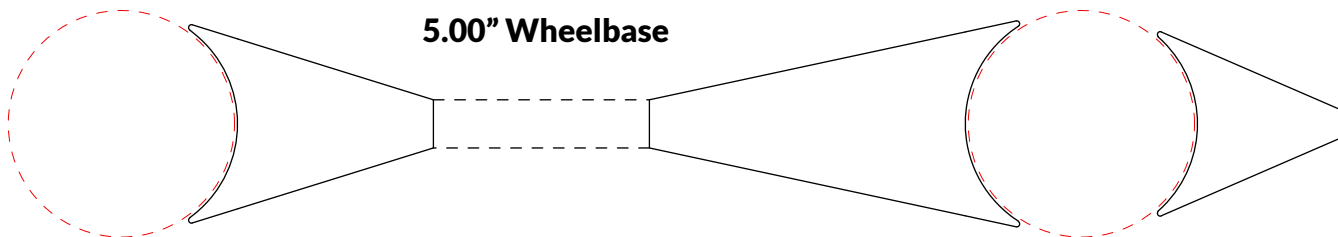

5.25" Wheelbase

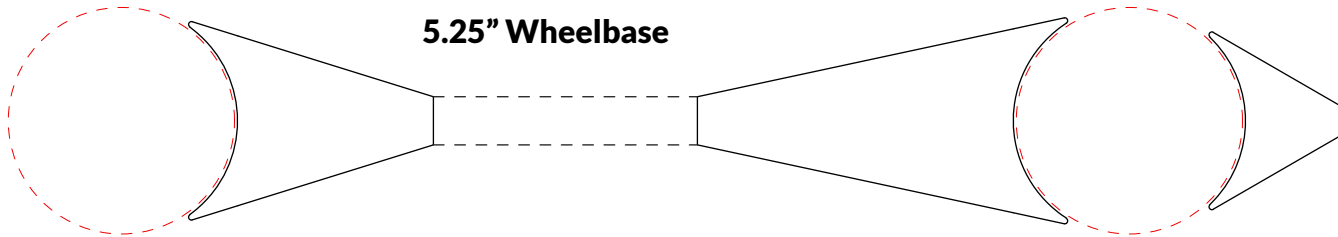

Print at 100%, do NOT choose "Fit to Page"

Print at 100%, do NOT choose "Fit to Page"

