

MALIBU

PA-46-310P

SN 4608008
THRU 4608140

PILOT'S OPERATING HANDBOOK

AND

FAA APPROVED
AIRPLANE FLIGHT MANUAL

AIRPLANE
SERIAL NO. _____

AIRPLANE
REGIST. NO. _____

PA-46-310P
REPORT: VB-1300 FAA APPROVED BY:



D. H. TROMPLER
D.O.A. NO. SO-1
PIPER AIRCRAFT CORPORATION
VERO BEACH, FLORIDA

DATE OF APPROVAL:
AUGUST 6, 1986

THIS HANDBOOK INCLUDES THE MATERIAL REQUIRED TO BE FURNISHED TO THE PILOT BY THE FEDERAL AVIATION REGULATIONS AND ADDITIONAL INFORMATION PROVIDED BY THE MANUFACTURER AND CONSTITUTES THE FAA APPROVED AIRPLANE FLIGHT MANUAL. THIS HANDBOOK MUST BE CARRIED IN THE AIRPLANE AT ALL TIMES.

REVISED: APRIL 27, 1990



WARNING

EXTREME CARE MUST BE EXERCISED TO LIMIT THE USE OF THIS HANDBOOK TO APPLICABLE AIRCRAFT. THIS HANDBOOK IS VALID FOR USE WITH THE AIRPLANE IDENTIFIED ON THE FACE OF THE TITLE PAGE. SUBSEQUENT REVISIONS SUPPLIED BY PIPER AIRCRAFT CORPORATION MUST BE PROPERLY INSERTED.

FOR REFERENCE ONLY
NOT FOR FLIGHT

This handbook meets GAMA Specification No. 1, SPECIFICATION FOR PILOT'S OPERATING HANDBOOK, issued February 15, 1975 and revised September 1, 1984.

Published by
PUBLICATIONS DEPARTMENT
Piper Aircraft Corporation
Issued: July 1, 1986



FOR REFERENCE ONLY
NOT FOR FLIGHT

N35646

THIS PAGE INTENTIONALLY LEFT BLANK

FOR REFERENCE ONLY
NOT FOR FLIGHT

APPLICABILITY

Application of this handbook is limited to the specific Piper PA-46-310P model airplane designated by serial number and registration number on the face of the title page of this handbook.

This handbook cannot be used for operational purposes unless kept in a current status.

WARNING

INSPECTION, MAINTENANCE AND PARTS REQUIREMENTS FOR ALL NON-PIPER APPROVED STC INSTALLATIONS ARE NOT INCLUDED IN THIS HANDBOOK. WHEN A NON-PIPER APPROVED STC INSTALLATION IS INCORPORATED ON THE AIRPLANE, THOSE PORTIONS OF THE AIRPLANE AFFECTED BY THE INSTALLATION MUST BE INSPECTED IN ACCORDANCE WITH THE INSPECTION PROGRAM PUBLISHED BY THE OWNER OF THE STC. SINCE NON-PIPER APPROVED STC INSTALLATIONS MAY CHANGE SYSTEMS INTERFACE, OPERATING CHARACTERISTICS AND COMPONENT LOADS OR STRESSES ON ADJACENT STRUCTURES, PIPER PROVIDED INSPECTION CRITERIA MAY NOT BE VALID FOR AIRPLANES WITH NON-PIPER APPROVED STC INSTALLATIONS.

REVISIONS

The information compiled in the Pilot's Operating Handbook, with the exception of the equipment list, will be kept current by revisions distributed to the airplane owners. The equipment list was current at the time the airplane was licensed by the manufacturer and thereafter must be maintained by the owner.

Revision material will consist of information necessary to update the text of the present handbook and/or to add information to cover added airplane equipment.

I. Revisions

Revisions will be distributed whenever necessary as complete page replacements or additions and shall be inserted into the handbook in accordance with the instructions given below:

1. Revision pages will replace only pages with the same page number.
2. Insert all additional pages in proper numerical order within each section.
3. Insert page numbers followed by a small letter in direct sequence with the same common numbered page.

II. Identification of Revised Material

Each handbook page is dated at the bottom of the page showing the date of original issue and the date of the latest revision. Revised text and illustrations are indicated by a black vertical line located along the outside margin of each revised page opposite the revised, added, or deleted information. A vertical line next to the page number indicates that an entire page has been changed or added.

Vertical black lines indicate current revisions only. Correction of typographical or grammatical errors or the physical relocation of information on a page will not be indicated by a symbol.

ORIGINAL PAGES ISSUED

The original pages issued for this handbook prior to revision are given below:

Title, ii through vii, 1-1 through 1-12, 2-1 through 2-11, 3-1 through 3-28, 4-1 through 4-34, 5-1 through 5-30, 6-1 through 6-19, 7-1 through 7-46, 8-1 through 8-21, 9-1 through 9-112, and 10-1 through 10-2.

**PIPER AIRCRAFT CORPORATION
PA-46-310P, MALIBU**

PILOT'S OPERATING HANDBOOK LOG OF REVISIONS

Current Revisions to the PA-46-350P Malibu Pilot's Operating Handbook,
REPORT: VB-1300 issued JULY 1, 1986

Revision Number and Code	Revised Pages	Description of Revisions	FAA Approved Signature and Date
Rev. 1 (PR870410)	3-21	Revised para. 3.27.	
	4-7	Revised Before Starting checklist.	
	4-10	Added Caution to Ground Check checklist.	
	4-12	Added Note to Takeoff Climb checklist.	
	4-13	Revised Cruise Climb checklist.	
		Added Warning and Note to Cruising checklist.	
		Relocated info. to page 4-13.	
	4-14	Relocated info. from page 4-12.	
		Added Warning to Approach And Landing checklist.	
	4-17	Revised Approach And Landing checklist.	
	4-19	Relocated info. to page 4.14.	
	4-22	Relocated Normal and Short Field Technique from page 4-13	
	4-17	Revised para. 4.9.	
	4-19	Added info. to para. 4.11.	
	4-22	Relocated Caution from page 4-23.	
4-23	Relocated info. to page 4-23.		
4-26	Revised para. 4.19.		
	Relocated info. from page 4-22.		
	Relocated Caution to page 4-22.		

PIPER AIRCRAFT CORPORATION
PA-46-310P, MALIBU

PILOT'S OPERATING HANDBOOK LOG OF REVISIONS (cont)

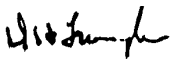
Revision Number and Code	Revised Pages	Description of Revisions	FAA Approved Signature and Date
Rev. 1 cont.	4-27	Relocated Note to page 4-26. Relocated info. from page 4-26. Revised para. 4.27. Added Note.	 D.H. Trompler June 5, 1987 Date
	4-28	Revised para. 4.27.	
	4-30	Added Note to para. 4.31. Added Warning to para. 4.31.	
	4-31	Relocated para. 4.33 to page 4-31. Relocated para. 4.33 from page 4-30. Relocated Note and info. to page 4-32 text.	
	4-32	Relocated Note and info. from page 4-31. Relocated Note to page 4-33.	
	4-33	Relocated Note from page 4-32. Relocated info. to page 4-34.	
	4-34	Relocated info from page 4-33.	
	5-9	Revised Table of Contents.	
	5-20	Revised graph title	
	5-21	Added fig. 5-20.	
	5-22	Revised fig. 5-21. Revised info.	
	7-8	Revised para. 7.7.	
	7-21	Revised fig. 7-13.	
	7-23	Revised fig. 7-15.	
	7-41	Revised para. 7.31.	
	8-11	Revised para. 8.21.	
	8-12	Revised para. 8.23.	
	9-i	Revised Table of Contents.	
	9-82	Revised fig. 4-1.	
	9-113 thru 9-118	Added Supplement No. 11.	
	9-119 thru 9-124	Added Supplement No. 12.	
	9-125 thru 9-128	Added Supplement No. 13.	

**PIPER AIRCRAFT CORPORATION
PA-46-310P, MALIBU**

PILOT'S OPERATING HANDBOOK LOG OF REVISIONS

Revision Number and Code	Revised Pages	Description of Revisions	FAA Approved Signature and Date
Rev. 2 (871027)	9-i 9-129 thru 9-134	Revised Table of Contents. Added Supplement 14	 D.H. Trompler <u>Nov. 2, 1987</u> Date
Rev. 3 (871216)	iv 4-10 4-23 4-33 5-3, 5-6, 5-7 7-i 7-11 7-15 7-29 7-37, 7-38 7-46 8-19 9-23 9-24 9-28 9-29 9-58 9-59 9-60	Revised Original Pages Issued. Revised Ground Check checklist. Revised para. 4.19. Revised para. 4.45. Revised para. 5.5. Corrected Report number. Corrected spelling. Revised para. 7.15. Corrected spelling. Revised para. 7.29. Revised Warning. Added Caution. Added fig. number. Revised item 5. Added fig. reference. Revised items 6, 8, and 9. Revised item 10. Revised item 4. Added fig. 7-1. Moved info. to page 9-59. Relocated info. from page 9-58. Moved info. to page 9-60. Relocated info. from page 9-59. Moved info. to page 9-61.	

ISSUED: OCTOBER 27, 1987

REVISED: DECEMBER 16, 1987

REPORT: VB-1300

vi-a



PIPER AIRCRAFT CORPORATION
PA-46-310P, MALIBU

PILOT'S OPERATING HANDBOOK LOG OF REVISIONS (cont)

Revision Number and Code	Revised Pages	Description of Revisions	FAA Approved Signature and Date
Rev. 3 Cont.	9-61 9-65 9-74 9-88 9-94 9-95 9-130 9-134	Relocated info. from page 9-60. Added item (h) (3). Corrected spelling. Revised fig. 7-1. Corrected spelling. Revised format. Revised format. Revised Section 2(d). Revised fig. 7-3.	 D.H. Trompler <u>Dec. 22, 1987</u> Date
Rev. 4 (PR881007)	v 4-27 8-i 8-1 8-2 8-3 9-i 9-113 9-119 9-121 9-127 9-135 thru 9-140	Corrected Rev. 1 date. Revised para. 4.27. Revised footer info. Revised para. 8.1. Revised para's. 8.1 and 8.3. Relocated info. from page 8-3. Info. moved to page 8-2. Revised Table Of Contents. Revised Piper Dwg. no. Added Date of Approval. Added Date of Approval. Revised Section 4, para. (b), (4) format. 125 Added Date of Approval. Revised Section 4, para. (b), (4) format. Added Supplement No. 15.	

**PIPER AIRCRAFT CORPORATION
PA-46-310P, MALIBU**

PILOT'S OPERATING HANDBOOK LOG OF REVISIONS

Revision Number and Code	Revised Pages	Description of Revisions	FAA Approved Signature and Date
Rev. 5 (PR881201)	8-11	Revised para. 8.21.	 D. H. Trompler <u>Jan. 10, 1989</u> Date
	9-i	Revised Table of Contents.	
	9-3	Revised Supplement No. 1 title and para.	
	9-4	Revised Section 1. Revised Section 2, para. (e). Revised Note.	
	9-5	Revised maximum altitude loss.	
Rev. 6 (PR891122)	4-6	Revised Warning.	 D. H. Trompler <u>Dec. 15, 1989</u> Date
	4-18	Revised Warning.	
	5-18	Revised fig. 5-15.	
	5-29	Revised fig. 5-33.	
	8-12	Revised para. 8.23.	
	9-i	Revised Table of Contents.	
	9-4	Revised Note.	
	9-63	Revised Supplement No. 4 Title. Revised para.	
	9-64	Revised Section 1 para.	
	9-65	Revised Figure.	
9-103	Added Caution.		
Rev. 7 (PR900208)	9-103	Revised Caution.	 D. H. Trompler <u>Feb. 13, 1990</u> Date

**ISSUED: DECEMBER 1, 1988
REVISED: FEBRUARY 8, 1990**

**REPORT: VB-1300
vi-c**

PIPER AIRCRAFT CORPORATION
PA-46-310P, MALIBU

PILOT'S OPERATING HANDBOOK LOG OF REVISIONS (cont)

Revision Number and Code	Revised Pages	Description of Revisions	FAA Approved Signature and Date
Rev. 8 (PR900427)	Title 5-29 6-i 7-21 7-23 9-i 9-141 thru 9-150	Revised Serial Applicability. Corrected header. Revised Table of Contents. Revised fig. 7-13. Revised fig. 7-15. Revised Table of Contents. Added Supplement No. 16	 D. H. Trompler <u>May 14, 1990</u> Date
Rev. 9 (PR910318)	vi-e, vi-f 4-12 7-i 7-21 7-23 7-31 8-3 9-4 9-5 9-6 9-7 9-8 9-60	Pages added. Added revision date. Revised page header. Revised fig. 7-13 lists of items operated off Emerg. and Main Buses. Revised fig. 7-15 lists of items operated off Emerg. and Main Buses. Revised fig. 7-23. Revised para. 8.5. Revised AC designation in Note. Revised page designation in footer. Revised Note. Renumbered items (7) thru (9) as (8) thru (10). Added new item (7). Added Note. Designated item (b) (1) a. Added item (b) (1) b. Moved info. to page 9-7. Relocated info. from page 9-6. Moved info. to page 9-8. Relocated info. from page 9-7. Revised items (3) and (4).	

**PIPER AIRCRAFT CORPORATION
PA-46-310P, MALIBU**



PILOT'S OPERATING HANDBOOK LOG OF REVISIONS

Revision Number and Code	Revised Pages	Description of Revisions	FAA Approved Signature and Date
Rev. 9 (cont.)	9-64	Revised Supplement number in header.	 D. H. Trompler <u>April 22, 1991</u> Date
	9-103	Revised item (d).	
	9-119	Corrected Date of Approval.	
	9-142	Added para. to Section 4.	
Rev. 10 (PR911014)	2-4	Added para. 2.11, (h).	
	3-12	Gyro Suction Failure sub-header revised.	
	3-27	Gyro Suction Failure sub-header revised. Deleted info. from para. 3.45.	
	4-10	Ground Check checklist revised. Note added. Info. moved to page 4-11.	
	4-11	Items added to Ground Check checklist. Note added. Info. relocated from page 4-10. Info. moved to page 4-12.	
	4-12	Info. relocated from page 4-11. Info. moved to page 4-13.	
	4-13	Info. relocated from page 4-12. Info. moved to page 4-14.	
	4-14	Info. relocated from page 4-13. Info. moved to page 4-14a.	
	4-14a	Page added. Info. relocated from page 4-14.	
	4-14b	Page added.	
	4-23	Para. 4.19 revised. Added Note to para's. 4.19 and 4.21. Moved info. to page 4-24.	
	4-24	Info. relocated from page 4-23. Info. moved to page 4-25.	
4-25	Info. relocated from page 4-24.		

PILOT'S OPERATING HANDBOOK LOG OF REVISIONS

Revision Number and Code	Revised Pages	Description of Revisions	FAA Approved Signature and Date
Rev. 10 cont.	7-37	Para. 7.29 revised and info. deleted. Info relocated from page 7-38.	<p style="text-align: center;"><i>W.R. Moreu</i></p> <p style="text-align: center;">W. R. Moreu FAA/DOA Coordinator</p> <p style="text-align: center;"><u>29 OCT 91</u> Date</p>
	7-38	Para. 7.29 revised and info. deleted. Info moved to page 7-37.	
	9-4	Revised Section 2, para. (e).	
	9-5	Revised Note.	
	9-6	Info. deleted from para. 4., a. Revised Note.	
	9-103	Revised Note	
Rev. 11 (PR930820)	4-11	Para. 4.5 revised. (Note)	<p style="text-align: center;"><i>W.R. Moreu</i></p> <p style="text-align: center;">W. R. Moreu FAA/DOA Coordinator</p> <p style="text-align: center;"><u>23 AUG 1993</u> Date</p>
	4-23	Para. 4.21 revised. (Note)	
	4-27	Para. 4.27 revised.	
	7-6	Added Para. 7.6	
	7-8	Info. relocated to 7-9	
	7-i	Added Para. 7.6 to TOC	
	9-3	DELETED Supplement 1	
	9-100	Revised SECTION 3	
	9-i	Revised Table of Contents	
Rev. 12 (PR971031)	vi-f	Added Rev. 12 to L of R.	
	vi-g	Added page.	
	vi-h	Added page.	
	3-9	Revised para. 3.3.	
	3-24	Revised para. 3.33.	
	4-11	Revised para. 4.5.	
	4-24	Revised para. 4.21	
	8-i	Revised T of C.	
8-ii	Added page.		

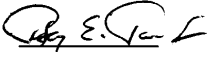
PILOT'S OPERATING HANDBOOK LOG OF REVISIONS

Revision Number and Code	Revised Pages	Description of Revisions	FAA Approved Signature and Date
Rev. 12 (continued)	8-17 8-18 8-22 8-23 8-24 9-98 9-101 9-102 9-104 9-106	Revised para. 8.35. Revised para. 8.35. Added page & para. 8.36. Added page & para. 8.36. Added page. Revised Section 2. Revised Section 4. Revised Section 4. Revised Section 4. Revised Section 7.	 Peter E. Peck <u>Oct. 31, 1997</u> Date
Rev. 13 (PR990225)	vi-g 2-i 2-9 2-10 2-11 2-12 3-i 3-ii 3-5 3-6 3-7 3-21 3-22 3-23 4-ii 4-35 4-36 9-i 9-3 9-102	Added Rev. 13 to L of R page. Revised T of C. Added para. 2.32. Relocated info. from page 2-9. Relocated info. from page 2-10. Added page & relocated info. from page 2-11. Revised T of C. Revised T of C. Relocated info. from page 3-6. Added TIT info. & relocated info. to pages 3-5, 3-6. Relocated info. from page 3-6. Added TIT info. & relocated info. to page 3-22. Relocated info. from page 3-21 & to page 3-23. Relocated info. from page 3-22. Revised T of C. Added page & para. 4.49. Added page. Revised T of C. Revised text. Revised Section 4.	 Peter E. Peck <u>Feb. 25, 1999</u> Date

PILOT'S OPERATING HANDBOOK LOG OF REVISIONS

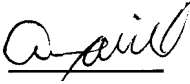
Revision Number and Code	Revised Pages	Description of Revisions	FAA Approved Signature and Date
Rev. 14 (PR021014)	iii	Added Warning and moved info. to page iv.	
	iv	Moved info. from page iii.	
	vi-h	Added Rev. 14 to L of R.	
	8-1	Moved info. to page 8-1B and revised para. 8.1.	
	8-1A	Added page and revised para. 8.1.	
	8-1B	Added page and moved info. from pages 8-1 and 8-2.	
	8-2	Moved info. to page 8-1B & 8-3, and revised para. 8.3.	Albert, J. Mill
	8-3	Moved info. from page 8-2.	<u>Oct. 14, 2002</u> Date

FOR REFERENCE ONLY
NOT FOR FLIGHT

TABLE OF CONTENTS

SECTION 1	GENERAL
SECTION 2	LIMITATIONS
SECTION 3	EMERGENCY PROCEDURES
SECTION 4	NORMAL PROCEDURES
SECTION 5	PERFORMANCE
SECTION 6	WEIGHT AND BALANCE
SECTION 7	DESCRIPTION AND OPERATION OF THE AIRPLANE AND ITS SYSTEMS
SECTION 8	AIRPLANE HANDLING, SERVICING AND MAINTENANCE
SECTION 9	SUPPLEMENTS
SECTION 10	OPERATING TIPS

THIS PAGE INTENTIONALLY LEFT BLANK

FOR REFERENCE ONLY
NOT FOR FLIGHT

TABLE OF CONTENTS

SECTION 1

GENERAL

Paragraph No.		Page No.
1.1	Introduction	1-1
1.3	Engine.....	1-3
1.5	Propeller	1-3
1.7	Fuel.....	1-3
1.9	Oil.....	1-4
1.11	Maximum Weights	1-4
1.13	Standard Airplane Weights.....	1-4
1.15	Cabin and Entry Dimensions.....	1-5
1.17	Baggage Space and Entry Dimensions.....	1-5
1.19	Specific Loading.....	1-5
1.21	Symbols, Abbreviations and Terminology	1-7

THIS PAGE INTENTIONALLY LEFT BLANK

FOR REFERENCE ONLY
NOT FOR FLIGHT

SECTION 1
GENERAL

1.1 INTRODUCTION

This Pilot's Operating Handbook is designed for maximum utilization as an operating guide for the pilot. It includes the material required to be furnished to the pilot by the Federal Aviation Regulations and additional information provided by the manufacturer and constitutes the FAA Approved Airplane Flight Manual.

This handbook is not designed as a substitute for adequate and competent flight instruction, knowledge of current airworthiness directives, applicable federal air regulations or advisory circulars. It is not intended to be a guide for basic flight instruction or a training manual and should not be used for operational purposes unless kept in a current status.

Assurance that the airplane is in an airworthy condition is the responsibility of the owner. The pilot in command is responsible for determining that the airplane is safe for flight. The pilot is also responsible for remaining within the operating limitations as outlined by instrument markings, placards, and this handbook.

Although the arrangement of this handbook is intended to increase its in-flight capabilities, it should not be used solely as an occasional operating reference. The pilot should study the entire handbook to familiarize himself with the limitations, performance, procedures and operational handling characteristics of the airplane before flight.

The handbook has been divided into numbered (arabic) sections each provided with a "finger-tip" tab divider for quick reference. The limitations and emergency procedures have been placed ahead of the normal procedures, performance and other sections to provide easier access to information that may be required in flight. The Emergency Procedures Section has been furnished with a red tab divider to present an instant reference to the section. Provisions for expansion of the handbook have been made by the deliberate omission of certain paragraph numbers, figure numbers, item numbers and pages noted as being intentionally left blank.

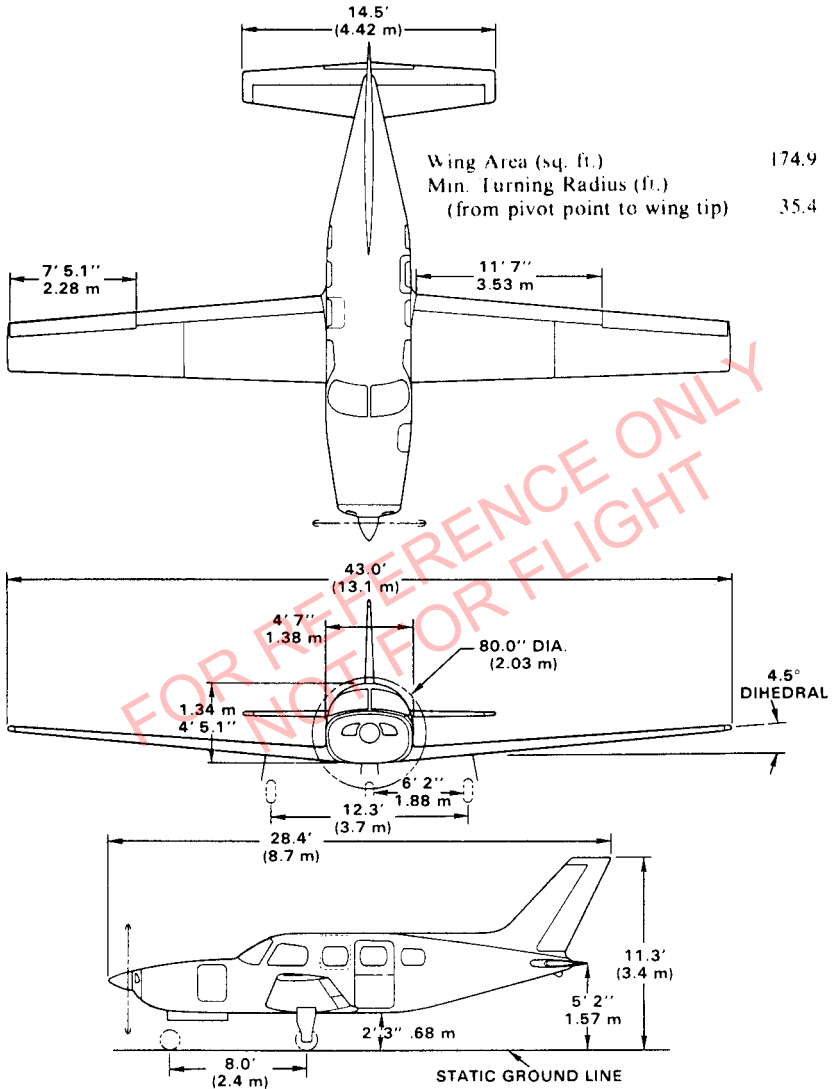

THREE VIEW
Figure 1-1

1.3 ENGINE

(a) Number of Engines	1
(b) Engine Manufacturer	Teledyne Continental
(c) Engine Model Number	TSIO-520-BE
(d) Rated Horsepower	310
(e) Rated Speed (rpm)	2600
(f) Maximum Manifold Pressure (in. Hg.)	38.0
(g) Bore (inches)	5.25
(h) Stroke (inches)	4.00
(i) Displacement (cubic inches)	520
(j) Compression Ratio	7.5:1
(k) Engine Type	Six Cylinder, Direct Drive, Horizontally Opposed, Air Cooled, Turbocharged, Fuel Injected

1.5 PROPELLER

(a) Number of Propellers	1
(b) Propeller Manufacturer	Hartzell
(c) Blade Model	F8052()
(d) Number of Blades	2
(e) Hub Model	BHC-C2YF-1BF
(f) Propeller Diameter (inches)	
(1) Minimum	78
(2) Maximum	80
(g) Propeller Type	Constant Speed, Hydraulically Actuated

1.7 FUEL

AVGAS ONLY

(a) Fuel Capacity (U.S. gal.) (total)	122
(b) Usable Fuel (U.S. gal.) (total)	120
(c) Fuel	
(1) Minimum Grade	100- Green or 100LL Blue Aviation Grade
(2) Alternate Fuels	Refer to latest revision of Continental Service Bulletin (Recommended Fuel and Oil Grades)

1.9 OIL

- (a) Oil Capacity (U.S. quarts) 8
- (b) Oil Specification Refer to latest revision of Continental Service Bulletin (Recommended Fuel and Oil Grades)
- (c) Oil Viscosity per Average Ambient Temperature for Starting

	Aviation Grade	S.A.E. No.	Multi-Viscosity Grade
Below 40°F	65	30	15W - 50 20W - 50
Above 40°F	100	50	15W - 50 20W - 50 25W - 60

When operating temperatures overlap indicated ranges, use the lighter grade oil. Multi-viscosity oils meeting TCM specification MHS-24A are approved.

1.11 MAXIMUM WEIGHTS

- (a) Maximum Ramp Weight (lbs.) 4118
- (b) Maximum Takeoff Weight (lbs.) 4100
- (c) Maximum Landing Weight (lbs.) 3900
- (d) Maximum Zero Fuel Weight (lbs.) 3900
- (e) Maximum Weights in Baggage Compartments (lbs.)
 - (1) Forward 100
 - (2) Aft 100

1.13 STANDARD AIRPLANE WEIGHTS

Refer to Figure 6-5 for the Standard Empty Weight and the Useful Load.

1.15 CABIN AND ENTRY DIMENSIONS (IN.)

(a) Cabin Width (max.)	49.5
(b) Cabin Length (Instrument panel to rear bulkhead)	148
(c) Cabin Height (max.)	47
(d) Entry Width	24
(e) Entry Height	46

1.17 BAGGAGE SPACE AND ENTRY DIMENSIONS

(a) Compartment Volume (cu. ft.)	
(1) Forward	14
(2) Aft	20
(b) Entry Dimensions (in.)	
(1) Forward	19 x 23
(2) Aft	24 x 46

1.19 SPECIFIC LOADING

(a) Wing Loading (lbs. per sq. ft.)	23.4
(b) Power Loading (lbs. per hp)	13.2

THIS PAGE INTENTIONALLY LEFT BLANK

FOR REFERENCE ONLY
NOT FOR FLIGHT

1.21 SYMBOLS, ABBREVIATIONS AND TERMINOLOGY

The following definitions are of symbols, abbreviations and terminology used throughout the handbook and those which may be of added operational significance to the pilot.

(a) General Airspeed Terminology and Symbols

CAS	Calibrated Airspeed means the indicated speed of an aircraft, corrected for position and instrument error. Calibrated airspeed is equal to true airspeed in standard atmosphere at sea level.
KCAS	Calibrated Airspeed expressed in ``Knots.’’
GS	Ground Speed is the speed of an airplane relative to the ground.
IAS	Indicated Airspeed is the speed of an aircraft as shown on the airspeed indicator when corrected for instrument error. IAS values published in this handbook assume zero instrument error.
KIAS	Indicated Airspeed expressed in ``Knots.’’
M	Mach Number is the ratio of true airspeed to the speed of sound.
TAS	True Airspeed is the airspeed of an airplane relative to undisturbed air which is the CAS corrected for altitude, temperature and compressibility.
V _A	Maneuvering Speed is the maximum speed at which application of full available aerodynamic control will not overstress the airplane.
V _{FE}	Maximum Flap Extended Speed is the highest speed permissible with wing flaps in a prescribed extended position.

V _{LE}	Maximum Landing Gear Extended Speed is the maximum speed at which an aircraft can be safely flown with the landing gear extended.
V _{LO}	Maximum Landing Gear Operating Speed is the maximum speed at which the landing gear can be safely extended or retracted.
V _{NE/MNE}	Never Exceed Speed or Mach Number is the speed limit that may not be exceeded at any time.
V _{NO}	Maximum Structural Cruising Speed is the speed that should not be exceeded except in smooth air and then only with caution.
V _S	Stalling Speed or the minimum steady flight speed at which the airplane is controllable.
V _{SO}	Stalling Speed or the minimum steady flight speed at which the airplane is controllable in the landing configuration.
V _X	Best Angle-of-Climb Speed is the airspeed which delivers the greatest gain of altitude in the shortest possible horizontal distance.
V _Y	Best Rate-of-Climb Speed is the airspeed which delivers the greatest gain in altitude in the shortest possible time.

(b) Meteorological Terminology

ISA	International Standard Atmosphere in which: <ol style="list-style-type: none">(1) The air is a dry perfect gas;(2) The temperature at sea level is 15° Celsius (59° Fahrenheit);(3) The pressure at sea level is 29.92 inches hg. (1013.2 mb);(4) The temperature gradient from sea level to the altitude at which the temperature is -56.5°C (-69.7°F) is -0.00198°C (-0.003564°F) per foot and zero above that altitude.
OAT	Outside Air Temperature is the free air static temperature obtained either from inflight temperature indications or ground meteorological sources, adjusted for instrument error and compressibility effects.
Indicated Pressure Altitude	The number actually read from an altimeter when the barometric subscale has been set to 29.92 inches of mercury (1013.2 millibars).
Pressure Altitude	Altitude measured from standard sea-level pressure (29.92 in. Hg) by a pressure or barometric altimeter. It is the indicated pressure altitude corrected for position and instrument error. In this handbook, altimeter instrument errors are assumed to be zero.
Station Pressure	Actual atmospheric pressure at field elevation.
Wind	The wind velocities recorded as variables on the charts of this handbook are to be understood as the headwind or tailwind components of the reported winds.

(c) Power Terminology

Takeoff Power	Maximum power permissible for takeoff.
Maximum Continuous Power	Maximum power permissible continuously during flight.
Maximum Climb Power	Maximum power permissible during climb.
Maximum Cruise Power	Maximum power permissible during cruise.

(d) Engine Instruments

T.I.T. Gauge	Turbine Inlet Temperature
--------------	---------------------------

(e) Airplane Performance and Flight Planning Terminology

Climb Gradient	The demonstrated ratio of the change in height during a portion of a climb, to the horizontal distance traversed in the same time interval.
Demonstrated Crosswind Velocity	The demonstrated crosswind velocity is the velocity of the crosswind component for which adequate control of the airplane during takeoff and landing was actually demonstrated during certification tests.
Accelerate-Stop Distance	The distance required to accelerate an airplane to a specified speed and, assuming failure of an engine at the instant that speed is attained, to bring the airplane to a stop.
Route Segment	A part of a route. Each end of that part is identified by (1) a geographical location or (2) a point at which a definite radio fix can be established.

(f) Weight and Balance Terminology

Reference Datum	An imaginary vertical plane from which all horizontal distances are measured for balance purposes.
Station	A location along the airplane fuselage usually given in terms of distance from the reference datum.
Arm	The horizontal distance from the reference datum to the center of gravity (C.G.) of an item.
Moment	The product of the weight of an item multiplied by its arm. (Moment divided by a constant is used to simplify balance calculations by reducing the number of digits.)
Center of Gravity (C.G.)	The point at which an airplane would balance if suspended. Its distance from the reference datum is found by dividing the total moment by the total weight of the airplane.
C.G. Arm	The arm obtained by adding the airplane's individual moments and dividing the sum by the total weight.
C.G. Limits	The extreme center of gravity locations within which the airplane must be operated at a given weight.
Usable Fuel	Fuel available for flight planning.
Unusable Fuel	Fuel remaining after a runout test has been completed in accordance with governmental regulations.
Standard Empty Weight	Weight of a standard airplane including unusable fuel, full operating fluids and full oil.

**SECTION 1
GENERAL**

**PIPER AIRCRAFT CORPORATION
PA-46-310P, MALIBU**

Basic Empty Weight	Standard empty weight plus optional equipment.
Payload	Weight of occupants, cargo and baggage.
Useful Load	Difference between takeoff weight, or ramp weight if applicable, and basic empty weight.
Maximum Ramp Weight	Maximum weight approved for ground maneuver. (It includes weight of start, taxi and run up fuel.)
Maximum Takeoff Weight	Maximum Weight approved for the start of the takeoff run.
Maximum Landing Weight	Maximum weight approved for the landing touchdown.
Maximum Zero Fuel Weight	Maximum weight exclusive of usable fuel.

FOR REFERENCE ONLY
NOT FOR FLIGHT

TABLE OF CONTENTS

SECTION 2

LIMITATIONS

Paragraph No.		Page No.
2.1	General	2-1
2.3	Airspeed Limitations	2-1
2.5	Airspeed Indicator Markings	2-2
2.7	Power Plant Limitations	2-3
2.9	Leaning Limitations	2-3
2.11	Power Plant Instrument Markings	2-4
2.13	Weight Limits	2-4
2.15	Center of Gravity Limits	2-5
2.17	Maneuver Limits	2-5
2.19	Flight Load Factors	2-5
2.21	Kinds of Operation Equipment List	2-6
2.23	Fuel Limitations	2-7
2.25	Operating Altitude Limitations	2-8
2.27	Cabin Pressurization Limits	2-8
2.29	Noise Level.....	2-8
2.31	Maximum Seating Configuration	2-8
2.32	Icing Information.....	2-9
2.33	Placards	2-10

THIS PAGE INTENTIONALLY LEFT BLANK

FOR REFERENCE ONLY
NOT FOR FLIGHT

**SECTION 2
LIMITATIONS**

2.1 GENERAL

This section provides the FAA Approved operating limitations, instrument markings, color coding and basic placards necessary for operation of the airplane and its systems.

Limitations associated with those optional systems and equipment which require handbook supplements can be found in Section 9 (Supplements).

2.3 AIRSPEED LIMITATIONS

SPEED	KIAS	KCAS
Never Exceed Speed (V_{NE}) - Do not exceed this speed in any operation.	203	200
Maximum Structural Cruising Speed (V_{NO}) - Do not exceed this speed except in smooth air and then only with caution.	173	170
Design Maneuvering Speed (V_A) - Do not make full or abrupt control movements above this speed.		
At 4100 LBS. Gross Weight	135	133
At 2450 LBS. Gross Weight	103	102

CAUTION

Maneuvering speed decreases at lighter weight as the effects of aerodynamic forces become more pronounced. Linear interpolation may be used for intermediate gross weights. Maneuvering speed should not be exceeded while operating in rough air.

**SECTION 2
LIMITATIONS**

**PIPER AIRCRAFT CORPORATION
PA-46-310P, MALIBU**

SPEED	KIAS	KCAS
Maximum Speed for Pneumatic Boot Inflation.	183	180
Maximum Flaps Extended Speed (V_{FE}) - Do not exceed this speed at the given flap setting.		
10°	170	167
20°	135	132
36°	120	115
Maximum Landing Gear Extension Speed (V_{LO}) - Do not exceed this speed when extending the landing gear.	170	167
Maximum Landing Gear Retraction Speed (V_{LO}) - Do not exceed this speed when retracting the landing gear.	130	128
Maximum Landing Gear Extended Speed (V_{LE}) Do not exceed this speed with the landing gear extended.	200	197

2.5 AIRSPEED INDICATOR MARKINGS

MARKING	IAS
Red Radial Line (Never Exceed)	203 KTS
Yellow Arc (Caution Range - Smooth Air Only)	173 KTS to 203 KTS
Green Arc (Normal Operating Range)	69 KTS to 173 KTS
White Arc (Flap Down)	58 KTS to 120 KTS

2.7 POWER PLANT LIMITATIONS

(a) Number of Engines	1
(b) Engine Manufacturer	Teledyne Continental
(c) Engine Model No.	TSIO-520-BE
(d) Engine Operating Limits	
(1) Maximum Engine Speed	2600 RPM
(2) Maximum Oil Temperature	240° F
(3) Maximum Cylinder Head Temperature	460° F
(4) Turbine Inlet Temperature	
a. Maximum Continuous	1750° F
b. Maximum Temporary (30 Seconds)	1800° F
(5) Maximum Manifold Pressure	
a. At or below 24000 feet	38.0 in. Hg.
b. Above 24000 feet	35.0 in. Hg.
(e) Oil Pressure	
Minimum (red line)	10 PSI
Maximum (red line)	100 PSI
(f) Fuel Flow	
Maximum (red line)	40.0 gal/hr
(g) Fuel (AVGAS ONLY) (minimum grade)	100 or 100LL Aviation Grade
(h) Number of Propellers	1
(i) Propeller Manufacturer	Hartzell
(j) Propeller Hub and Blade Model	BHC-C2YF-1BF/F8052-()
(k) Propeller Diameter (inches)	
Minimum	78
Maximum	80
(l) Blade Angle Limits	
Low Pitch Stop	16.0° ± 0.2°
High Pitch Stop	38.0° ± 1°

2.9 LEANING LIMITATIONS

Mixture full RICH at all engine powers above 2400 RPM and 31 inches of Hg. manifold pressure (75% power).

2.11 POWER PLANT INSTRUMENT MARKINGS

- | | |
|---|----------------------------|
| (a) Tachometer | |
| Green Arc (Normal Operating Range) | 600 to 2600 RPM |
| Red Line (Maximum) | 2600 RPM |
| (b) Manifold Pressure | |
| Green Arc (Normal Operating Range) | 10 to 38.0 in. Hg |
| Red Line (Takeoff Power) | 38.0 in. Hg |
| (c) Oil Temperature | |
| Green Arc (Normal Cruise Range) | 100° to 200°F |
| Red Line (Maximum) | 240°F |
| (d) Oil Pressure | |
| Green Arc (Normal Cruise Range) | 30 PSI to 60 PSI |
| Yellow Arc (Caution Range) (Idle) | 10 PSI to 30 PSI |
| Yellow Arc (Caution Range)
(Start and Warm Up) | 60 PSI to 100 PSI |
| Red Line (Minimum) | 10 PSI |
| Red Line (Maximum) | 100 PSI |
| (e) Fuel Flow | |
| Green Arc (Normal Operating Range) | 6 gal/hr. to
40 gal/hr. |
| Red Line (Maximum) | 40 gal/hr. |
| (f) Turbine Inlet Temperature | |
| Green Arc (Normal Operating Range) | 1200°F to 1750°F |
| Red Line (Maximum) | 1750°F |
| (g) Cylinder Head Temperature | |
| Green Arc (Normal Operating Range) | 240°F to 420°F |
| Red Line (Maximum) | 460°F |
| (h) Vacuum Pressure | |
| Green Arc (Normal Operating Range) | 4.8 to 5.2 in. Hg |
| Red Line (Minimum) | 4.8 In. Hg |
| Red Line (Maximum) | 5.2 In. Hg |

2.13 WEIGHT LIMITS

- | | |
|--|-----------|
| (a) Maximum Ramp Weight | 4118 LBS. |
| (b) Maximum Takeoff Weight | 4100 LBS. |
| (c) Maximum Landing Weight | 3900 LBS. |
| (d) Maximum Zero Fuel Weight | 3900 LBS. |
| (e) Maximum Baggage (100 lbs.
each compartment) | 200 LBS. |

NOTE

Refer to Section 5 (Performance) for maximum weight as limited by performance.

2.15 CENTER OF GRAVITY LIMITS

Weight Pounds	Forward Limit Inches Aft of Datum	Rearward Limit Inches Aft of Datum
4100	143.3	147.1
3680	136.1	147.1
2450 (and less)	130.7	147.1

NOTES

Straight line variation between points given.

The datum used is 100.0 inches ahead of the forward pressure bulkhead.

It is the responsibility of the airplane owner and the pilot to insure that the airplane is properly loaded. See Section 6 (Weight and Balance) for proper loading instructions.

2.17 MANEUVER LIMITS

No acrobatic maneuvers including spins approved.

2.19 FLIGHT LOAD FACTORS

- (a) Positive Load Factor (Maximum)
 - (1) Flaps Up 3.8 G
 - (2) Flaps Down 2.0 G
- (b) Negative Load Factor (Maximum) No inverted maneuvers approved

2.21 KINDS OF OPERATION EQUIPMENT LIST

This airplane may be operated in day or night VFR, day or night IFR and known or forecast icing when the appropriate equipment is installed and operable.

The following equipment list identifies the systems and equipment upon which type certification for each kind of operation was predicated and must be installed and operable for the particular kind of operation indicated.

(a) Day VFR

- (1) Airspeed indicator
- (2) Altimeter
- (3) Magnetic compass
- (4) Tachometer
- (5) Oil pressure indicator
- (6) Oil temperature indicator
- (7) Fuel flow indicator
- (8) Manifold pressure indicator
- (9) Cylinder head temperature indicator
- (10) Turbine inlet temperature indicator
- (11) Fuel quantity indicator - each tank
- (12) Flap position indicator
- (13) Elevator/rudder trim position indicator
- (14) Volt-ammeter
- (15) Alternator
- (16) Gear position indicator lights
- (17) Gear warning horn
- (18) Safety restraint - each occupant
- (19) Hydraulic pressure gauge

(b) Night VFR

- (1) All equipment required for Day VFR
- (2) Position lights
- (3) Instrument lights
- (4) Anti-collision (strobe) lights

2.21 KINDS OF OPERATION EQUIPMENT LIST (Continued)

- (c) Day IFR
 - (1) All equipment required for Day VFR
 - (2) Vacuum pump
 - (3) Gyro suction indicator
- (d) Night IFR
 - (1) All equipment required for Day and Night VFR
 - (2) All equipment required for Day IFR
- (e) Required For Pressurized Flight
 - (1) Cabin Altimeter
 - (2) Cabin differential pressure indicator
 - (3) Cabin rate of climb indicator
 - (4) Pressure control valve
 - (5) Safety valve, pressure relief
 - (6) Pressurization controller
 - (7) Cabin altitude warning light
 - (8) Vacuum pump
- (f) Required For Flight Into Known Icing Conditions
 - (1) Refer to Section 9 Supplement 10.

NOTE

The above system and equipment list does not include specific flight instruments and communication/navigation equipment required by the FAR Part 91 and 135 operating requirements.

2.23 FUEL LIMITATIONS

- (a) Total Capacity.....122 U.S. GAL.
- (b) Unusable Fuel.....2 U.S. GAL.
The unusable fuel for this airplane has been determined as 1.0 gallon in each wing in critical flight attitudes.
- (c) Usable Fuel.....120 U.S. GAL.
The usable fuel in this airplane has been determined as 60 gallons in each wing.

2.21 KINDS OF OPERATION EQUIPMENT LIST (CONTINUED)

2.25 OPERATING ALTITUDE LIMITATIONS

Flight above 25,000 feet pressure altitude is not approved. Flight up to and including 25,000 feet is approved if equipped with avionics in accordance with F.A.R. 91 or F.A.R. 135.

2.27 CABIN PRESSURIZATION LIMITS

- (a) Pressurized flight operation approved at maximum cabin differential pressure of 5.5 psi.
- (b) Pressurized landing not approved.

2.29 NOISE LEVEL

The corrected noise level of this aircraft is 74.8 dB(A).

No determination has been made by the Federal Aviation Administration that the noise levels of this airplane are or should be acceptable or unacceptable for operation at, into, or out of, any airport.

The above statement notwithstanding, the noise level stated above has been verified by and approved by the Federal Aviation Administration in noise level test flights conducted in accordance with F.A.R. 36, Noise Standards - Aircraft Type and Airworthiness Certification. This aircraft model is in compliance with all F.A.R. 36 noise standards applicable to this type.

2.31 MAXIMUM SEATING CONFIGURATION

The maximum seating capacity is 6 (six) persons.

2.32 ICING INFORMATION

"WARNING"

Severe icing may result from environmental conditions outside of those for which the airplane is certified. Flight in freezing rain, freezing drizzle, or mixed icing conditions (supercooled liquid water and ice crystals) may result in ice build-up on protected surfaces exceeding the capability of the ice protection system, or may result in ice forming aft of the protected surfaces. This ice may not be shed using the ice protection systems, and may seriously degrade the performance and controllability of the airplane.

During flight, severe icing conditions that exceed those for which the airplane is certificated shall be determined by the following visual cues. If one or more of these visual cues exists, immediately request priority handling from Air Traffic Control to facilitate a route or an altitude change to exit the icing conditions.

Unusually extensive ice accumulation on the airframe and windshield in areas not normally observed to collect ice.

Accumulation of ice on the upper surface of the wing, aft of the protected area.

Accumulation of ice on the engine cowling and propeller spinner farther aft than normally observed.

Since the autopilot, when installed and operating, may mask tactile cues that indicate adverse changes in handling characteristics, use of the autopilot is prohibited when any of the visual cues specified above exist, or when unusual lateral trim requirements or autopilot trim warnings are encountered while the airplane is in icing conditions.

All wing icing inspection lights must be operative prior to flight into known or forecast icing conditions at night. [NOTE: This supersedes any relief provided by the Master Minimum Equipment List (MMEL).]

2.33 PLACARDS

In full view of the pilot:

The markings and placards installed in this airplane contain operating limitations which must be complied with when operating this airplane in the normal category. Other operating limitations which must be complied with when operating this airplane in this category are contained in the airplane flight manual. No acrobatic maneuvers, including spins, approved.

This aircraft approved for V.F.R., I.F.R., day and night icing flight when equipped in accordance with the Airplane Flight Manual.

In full view of the pilot, the following takeoff and landing checklists will be installed:

TAKEOFF CHECKLIST

Fuel on Proper Tank	Flaps Set
Engine Gauges Checked	Trim Set
Induction Air - Primary	Controls Free
Seat Backs Erect	Door Secured
Mixture Set	Air Conditioner Off
Propeller Set	Pressurization System - Set
Fasten Belts/Harnesses	

LANDING CHECKLIST

Fuel on Proper Tank	Gear Down
Seat Backs Erect	Flaps Set
Fasten Belts/Harnesses	Air Conditioner Off
Mixture - Rich	Cabin Pressure - Depressurized
Propeller - Set	

On the instrument panel in full view of the pilot:

V_A 135 KIAS at 4100 LBS
(See A.F.M.)

In full view of the pilot:

VLO 170 DN, 130 UP
VLE 200 MAX

Near emergency gear release:

EMERGENCY GEAR EXTENSION
PULL TO RELEASE. SEE A.F.M.
BEFORE RE-ENGAGEMENT

On the face of the turbine inlet temperature gauge:

CRUISE MIXTURE SETTING IS
50° LEAN OF PEAK T.I.T.
(See A.F.M.)

In full view of the pilot:

WARNING

TURN OFF STROBE LIGHTS WHEN IN
CLOSE PROXIMITY TO GROUND OR
DURING FLIGHT THROUGH CLOUD,
FOG OR HAZE.

Near the magnetic compass:

CAUTION - COMPASS CALIBRATION
MAY BE IN ERROR WITH ELECTRICAL
EQUIPMENT OTHER THAN AVIONICS
ON.

In full view of the pilot when the air conditioner is installed:

**WARNING - AIR CONDITIONER MUST
BE OFF TO INSURE NORMAL TAKEOFF
CLIMB PERFORMANCE.**

On the inside of the forward baggage door:

**MAXIMUM BAGGAGE THIS COMPART-
MENT 100 LBS.**

On aft baggage closeout:

**MAXIMUM BAGGAGE THIS COMPART-
MENT 100 LBS.**

In full view of the pilot:

PRESSURIZED LANDING NOT APPROVED

Adjacent to fuel tank filler caps:



Over emergency exit handle:

**EMERGENCY EXIT
REMOVE GLASS
PULL DOOR IN - LIFT UP**

TABLE OF CONTENTS
SECTION 3
EMERGENCY PROCEDURES

Paragraph No.		Page No.
3.1	General 3-1	
3.3	Emergency Procedures Checklist	3-2
	Engine Fire During Start	3-2
	Engine Power Loss During Takeoff.....	3-2
	Engine Power Loss In Flight	3-2
	Power Off Landing	3-3
	Fire In Flight.....	3-4
	Loss of Oil Pressure.....	3-5
	Loss of Fuel Flow	3-5
	Engine Driven Fuel Pump Failure	3-5
	High Oil Temperature.....	3-5
	High Cylinder Head Temperature.....	3-6
	Turbine Inlet Temperature (TIT) Indicator Failure.....	3-6
	Electrical Failures	3-6
	Electrical Overload	3-7
	Propeller Overspeed	3-9
	Emergency Landing Gear Extension	3-9
	Spin Recovery.....	3-10
	Engine Roughness	3-10
	Emergency Descent	3-10
	Pressurization System Malfunction.....	3-11
	Cabin Air Contamination/Smoke	
	Evacuation (Pressurized).....	3-12
	Gyro Suction Failure	3-12
	Inadvertent Icing Encounter or Flight	
	in Snow.....	3-13
	Hydraulic System Malfunction.....	3-13
	Flap System Malfunction	3-13

TABLE OF CONTENTS (cont)

SECTION 3 (cont)

Paragraph No.		Page No.
3.5	Amplified Emergency Procedures (General)	3-14
3.7	Engine Fire During Start	3-14
3.9	Engine Power Loss During Takeoff	3-14
3.11	Engine Power Loss In Flight	3-15
3.13	Power Off Landing	3-17
3.15	Fire In Flight.....	3-18
3.17	Loss of Oil Pressure	3-19
3.19	Loss of Fuel Flow.....	3-19
3.21	Engine Driven Fuel Pump Failure	3-20
3.23	High Oil Temperature.....	3-20
3.25	High Cylinder Head Temperature	3-21
3.26	Turbine Inlet Temperature (TIT) Indicator Failure	3-21
3.27	Electrical Failures.....	3-21
3.29	Electrical Overload.....	3-22
3.31	Propeller Overspeed	3-24
3.33	Emergency Landing Gear Extension.....	3-24
3.35	Spin Recovery	3-24
3.37	Engine Roughness	3-25
3.39	Emergency Descent	3-25
3.41	Pressurization System Malfunction.....	3-26
3.43	Cabin Air Contamination/Smoke Evacuation	3-26
3.45	Gyro Suction Failure	3-27
3.47	Inadvertent Icing Encounter or Flight in Snow	3-27
3.48	Hydraulic System Malfunction	3-28
3.49	Flap System Malfunction	3-28

**SECTION 3
EMERGENCY PROCEDURES**

3.1 GENERAL

The recommended procedures for coping with various types of emergencies and critical situations are provided by this section. All of the required (FAA regulations) emergency procedures and those necessary for operation of the airplane as determined by the operating and design features of the airplane are presented.

Emergency procedures associated with those optional systems and equipment which require handbook supplements are provided in Section 9 (Supplements).

The first portion of this section consists of an abbreviated emergency checklist which supplies an action sequence for critical situations with little emphasis on the operation of systems.

The remainder of the section is devoted to amplified emergency procedures containing additional information to provide the pilot with a more complete understanding of the procedures.

These procedures are suggested as a course of action for coping with the particular condition described, but are not a substitute for sound judgment and common sense. Pilots should familiarize themselves with the procedures given in this section and be prepared to take appropriate action should an emergency arise.

Most basic emergency procedures, such as a power off landings, are a normal part of pilot training. Although these emergencies are discussed here, this information is not intended to replace such training, but only to provide a source of reference and review, and to provide information on procedures which are not the same for all aircraft. It is suggested that the pilot review standard emergency procedures periodically to remain proficient in them.

3.3 EMERGENCY PROCEDURES CHECKLIST

ENGINE FIRE DURING START

- Startercrank engine
- Mixtureidle cut-off
- Throttleopen
- Aux. fuel pumpOFF
- Fuel selectorOFF
- Abandon if fire continues

ENGINE POWER LOSS DURING TAKEOFF

If sufficient runway remains for a normal landing, leave gear down and land straight ahead.

If area ahead is rough, or if it is necessary to clear obstructions:

- Landing gear selectorUP

If sufficient altitude has been gained to attempt a restart:

- Maintain safe airspeed
- Fuel selectorswitch to tank containing fuel
- Induction airALTERNATE
- Aux. fuel pumpHIGH
- Throttlereduce as necessary (approx. 75% power)

Upon restart, if normal engine operation is not established, promptly select LOW boost pump setting.

CAUTION

If normal engine operation and fuel flow is not immediately re-established, the aux. fuel pump should be turned OFF. The lack of fuel flow indication could indicate a leak in the fuel system.

ENGINE POWER LOSS IN FLIGHT

- Fuel selectorswitch to tank containing fuel

Aux. fuel pump.....LOW
Induction air.....ALTERNATE
Engine gaugescheck for indication
of cause of power loss

If power is restored:

Induction airPRIMARY
Aux. fuel pumpOFF

If power is not restored within ten seconds:

Aux. fuel pumpHIGH
MixtureFULL RICH
Throttleapprox. 75% power

CAUTION

If normal engine operation and fuel flow is not immediately re-established, the aux. fuel pump should be turned OFF. The lack of fuel flow indication could indicate a leak in the fuel system.

If power is not restored, prepare for power off landing.

Trim for 90 KIAS

POWER OFF LANDING

Prop control.....Full DECREASE

Best gliding angle 90 KIAS

Locate suitable field.

Establish spiral pattern.

1000 ft. above field at downwind position for normal landing approach.

When field can easily be reached slow to 77 KIAS for shortest landing.

Touchdowns should normally be made at lowest possible airspeed with flaps as required.

When committed to landing:

Gearas required

ThrottleCLOSED

Mixtureidle cut-off

Magneto switchesOFF

SECTION 3
EMERG PROCEDURES

PIPER AIRCRAFT CORPORATION
PA-46-310P, MALIBU

Aux. fuel pumpOFF
Fuel selectorOFF
Flapsas required
Battery switchOFF
ALTR switch(es)OFF
Seat belt and harnesstight

FIRE IN FLIGHT

Source of firecheck

NOTE

If pressurized, the following procedure will result in an immediate loss of pressurization and the cabin altitude will rise at an uncontrolled rate.

Electrical fire (smoke in cabin):

Cabin dump switchDUMP
Cabin pressurization controlPULL to unpressurize

After 5 second delay:

Battery switchOFF
ALTR switch(es)OFF
Cabin heatOFF

CAUTION

The dump valve will remain open if activated prior to turning the aircraft electrical system OFF. This provides maximum airflow through the cabin for smoke evacuation. Do not turn the cabin dump switch OFF. The dump valve will close and cannot be reactivated unless electrical power is turned on.

Emergency descentbelow 12,500 feet
Land as soon as possible.

WARNING

If emergency oxygen is installed, use ONLY if flames and heat are not present.

Engine fire:

- ThrottleCLOSED
 - Mixtureidle cut-off
 - Fuel selectorOFF
 - Magneto switchesOFF
 - Aux. fuel pumpcheck OFF
 - Heater and defrosterOFF
- Proceed with power off landing procedure.

LOSS OF OIL PRESSURE

Land as soon as possible and investigate cause. Prepare for power off landing.

LOSS OF FUEL FLOW

- Aux. fuel pumpLOW
- Fuel selectorcheck on tank
containing usable fuel

If power restored:

- Aux. fuel pumpOFF
- Mixtureas required

If power not restored within ten seconds:

- Aux. fuel pumpHIGH
- MixtureFULL RICH
- Throttleapprox. 75% power

ENGINE DRIVEN FUEL PUMP FAILURE

- Throttleretard
- Aux. fuel pumpHIGH
- Throttlereset as required
- Mixturereset as required

CAUTION

If normal engine operation and fuel flow is not immediately re-established, the auxiliary fuel pump should be turned OFF. The lack of a fuel flow indication could indicate a leak in the fuel system.

HIGH OIL TEMPERATURE

Land at nearest airport and investigate the problem. Prepare for power off landing.

HIGH CYLINDER HEAD TEMPERATURE

Powerreduce
Mixture.....enrich if practical
Land at nearest airport and investigate problem.

TURBINE INLET TEMPERATURE (TIT) INDICATOR FAILURE

CAUTION

Aircraft POH range and endurance data presented in Section 5 will no longer be applicable. Less range/endurance will result due to higher fuel flow/fuel consumption.

If failure occurs during takeoff, climb, descent, or landing:

MixtureFULL RICH

If failure occurs after setting cruise power:

Mixture6 GPH fuel flow above value in section 5 Power Setting Table

Cylinder Head and Oil TemperaturesMONITOR

NOTE

Repair TIT indicator as soon as possible.

ELECTRICAL FAILURES

CAUTION

The alternator output circuit breakers should never be opened manually when the alternators are functioning properly, as voltage regulator damage may occur.

ALTERNATOR annunciator light illuminated

Ammeter.....check to verify inop. alt.

Reduce electrical loads to minimum

ALTR circuit breakerscheck and reset as required

If ammeter shows zero

ALTR switch(es)OFF for 1 second, then ON

If power not restored (single alternator system)

ALTR switch.....OFF
Battery switch.....OFF
EMER BUS switch.....ON

Land as soon as practical. The battery is the only remaining source of electrical power.

NOTE

If the battery is depleted, the flaps will not operate and a flaps up landing will be required. The landing gear must be lowered using emergency extension procedures. The gear position lights will be inoperative.

If power not restored (dual alternator system)

ALTR switch (affected alternator)OFF
Electrical loadsreduce
Ammeter (operating alternator).....monitor

ELECTRICAL OVERLOAD (alternator more than 20 amps above known electrical load)

AIRCRAFT EQUIPPED WITH SINGLE ALTERNATOR

Electrical load.....reduce
ALTR No. 1 switch.....ON
Battery switch.....OFF

If alternator loads are reduced

Electrical loadreduce to minimum

Land as soon as practical.

NOTE

Due to increased system voltage and radio noise, operation with ALTR No. 1 switch ON and the battery switch OFF should be made only when required by an electrical system failure.

If alternator loads are not reduced

ALTR No. 1 switch.....OFF
Battery switchOFF
EMER BUS switch.....ON

Land as soon as possible. Anticipate complete electrical failure.

NOTE

If the battery is depleted, the landing gear must be lowered using the emergency extension procedure. The gear position lights will be inoperative. The flaps will also be inoperative and a flaps up landing will be required.

AIRCRAFT EQUIPPED WITH DUAL ALTERNATORS

Electrical load.....reduce below 60 amps
ALTR No. 1 switch.....OFF
ALTR No. 2 switch.....ON
Battery switchOFF

If alternator loads are reduced

Electrical loadreduce to minimum
ALTR No. 1 switch.....ON

Land as soon as practical.

NOTE

Due to increased system voltage and radio noise, operation with the ALTR switches ON and the battery switch OFF should be made only when required by an electrical system failure.

If alternator loads are not reduced

Battery switch.....ON
ALTR No. 2 switch.....OFF
ALTR No. 1 switch.....ON

If overload is not present, continue flight with ALTR No. 2 switch OFF.

If overload still persists

- ALTR No. 1 switch.....OFF
- ALTR No. 2 switch.....OFF
- Battery switchOFF
- EMER BUS switch.....ON

Land as soon as possible. Anticipate complete electrical failure.

NOTE

If the battery is depleted, the landing gear must be lowered using the emergency extension procedure. The gear position lights will be inoperative. The flaps will also be inoperative and a flaps up landing will be required.

PROPELLER OVERSPEED

- Throttleretard
- Oil pressurecheck
- Prop controlfull DECREASE rpm,
then set if any
control available
- Airspeed.....reduce
- Throttle.....as required to remain
below 2600 rpm

EMERGENCY LANDING GEAR EXTENSION

If all electrical power has been lost, the landing gear must be extended using the following procedures. The gear position indicator lights will not illuminate.

Prior to emergency extension procedure:

- Battery switchcheck ON
- Circuit breakers.....check
- DAY/NIGHT dimmer switchDAY (in daytime)

If landing gear does not check down and locked:

- Airspeedbelow 90 KIAS
- Hydraulic pump circuit breaker (25 amp).....PULL
- Landing gear selector.....DOWN
- Emergency gear extend control.....PULL
(while fishtailing airplane)

CAUTION

The emergency gear extension procedure will require the pilot to pull the emergency gear extend control knob through a region of high resistance (up to 25 pounds) in order to reach the stop and extend the landing gear.

SPIN RECOVERY

Rudder.....full opposite to
direction of rotation
Control wheel.....full forward while
neutralizing ailerons
ThrottleCLOSED
Rudder.....neutral (when rotation stops)
Control wheelas required to smoothly
regain level flight attitude

ENGINE ROUGHNESS

Mixture.....adjust for maximum smoothness
Induction air.....ALTERNATE
Aux. fuel pump.....LOW
Fuel selectorselect another tank

EMERGENCY DESCENT

NOTE

If pressurized, the following procedure will result in an immediate loss of pressurization and the cabin altitude will rise at an uncontrolled rate.

Seat belts and shoulder harnessessecure
ThrottleCLOSED
Prop control.....full INCREASE
Mixtureas required
Landing gearDOWN
(170 KIAS max.)
FlapsUP

SMOOTH AIR

Airspeed after landing gear is fully extended180-200 KIAS

ROUGH AIR

Airspeed after landing gear is fully extended4100 lbs. 135 KIAS
2450 lbs. 103 KIAS

PRESSURIZATION SYSTEM MALFUNCTION

Should the differential pressure rise above 5.5 psi maximum or a structural failure appear imminent, proceed as follows:

Cabin dump switchDUMP
Cabin pressurization controlPULL to unpressurize
Emergency descentbelow 12,500 feet

NOTE

If emergency oxygen is installed, don masks, activate oxygen generators, and check flow. Descend below 12,500 feet.

Should the aircraft suddenly lose pressurization, proceed as follows:

Cabin dump switchcheck OFF
Cabin pressurization controlcheck IN
Emergency descentbelow 12,500 feet

NOTE

If emergency oxygen is installed, don masks, activate oxygen generators, and check flow. Descend below 12,500 feet.

CABIN AIR CONTAMINATION/SMOKE EVACUATION (Pressurized)

Cabin dump switchDUMP
Cabin pressurization controlPULL to unpressurize
Vent/Defog fanON
Cabin recirculation fan.....OFF
Storm windowclosed
Emergency descent.....below 12,500 feet

NOTES

If emergency oxygen is installed, don masks, activate oxygen generators, and check flow. Descend below 12,500 feet.

If fumes/smoke dissipate land as soon as practical to investigate problem. If fumes/smoke persist, refer to Fire in Flight paragraph 3.15.

GYRO SUCTION FAILURE (Suction below 4.8 in. Hg.) (Aircraft not equipped with stand-by vacuum pump)

Unpressurized flight
Cabin dumpOFF
Cabin pressurization controlIN
Cabin differential pressureabove 2.3 PSID
Pressurized flight
Cabin differential pressureabove 2.3 PSID

NOTES

Cabin pressurization will supply a backup vacuum source above 2.3 PSID.

Monitor electrical directional gyro.

INADVERTENT ICING ENCOUNTER OR FLIGHT IN SNOW

Pitot heat.....ON
Cabin heatfull ON
Windshield defrost.....ON
Vent/Defog Fan.....ON

Change heading and/or altitude to exit icing conditions or snow.

Induction air.....monitor,
ALTERNATE if required

HYDRAULIC SYSTEM MALFUNCTION

HYD PUMP annunciator light illuminates continuously, or cycles on and off rapidly.

HYD PUMP circuit breaker.....pull
Land as soon as possible and investigate the cause.

FLAP SYSTEM MALFUNCTION

FLAPS annunciator light illuminated.

FLAP WARN/RESET circuit breaker Pull and reset
Verify normal flap operation.

If FLAPS annunciator light remains illuminated:

FLAP MOTOR circuit breakerPull

Land as soon as possible and investigate the cause.

3.5 AMPLIFIED EMERGENCY PROCEDURES (GENERAL)

The following paragraphs are presented to supply additional information for the purpose of providing the pilot with a more complete understanding of the recommended course of action and probable cause of an emergency situation.

3.7 ENGINE FIRE DURING START

Engine fires during start are usually the result of overpriming. The first attempt to extinguish the fire is to try to start the engine and draw the excess fuel back into the induction system.

If a fire is present before the engine has started, move the mixture control to idle cut-off, open the throttle and crank the engine. This is an attempt to draw the fire back into the engine.

If the engine has started, continue operating to try to pull the fire into the engine.

In either case (above), if fire continues more than a few seconds, the fire should be extinguished by the best available external means.

The fuel selector valve should be OFF and the mixture at idle cut-off if an external fire extinguishing method is to be used.

3.9 ENGINE POWER LOSS DURING TAKEOFF

The proper action to be taken if loss of power occurs during takeoff will depend on the circumstances of the particular situation.

If sufficient runway remains to complete a normal landing, leave the landing gear down and land straight ahead.

If the area ahead is rough, or if it is necessary to clear obstructions, move the landing gear selector switch to the UP position and prepare for a gear up landing.

If sufficient altitude has been gained to attempt a restart, maintain a safe airspeed and switch the fuel selector to another tank containing fuel. Move the induction air lever to the ALTERNATE position. Turn the auxiliary fuel pump on HIGH and retard the throttle until power is regained (approx. 75%).

Upon restart, if normal engine operation is not established promptly, select LOW pump setting.

If engine failure was caused by engine driven fuel pump failure the throttle must be retarded to regain power. The auxiliary fuel pump will not supply sufficient fuel to run the engine at full power.

If engine failure was caused by fuel exhaustion, power will not be regained after switching fuel tanks until the empty fuel lines are filled. This may require up to ten seconds.

If power is not regained, proceed with Power Off Landing procedure (refer to paragraph 3.13).

CAUTION

Actuation of the HIGH switch position of the auxiliary fuel pump after the engine is operating normally will cause engine roughness and/or power loss.

3.11 ENGINE POWER LOSS IN FLIGHT

Complete engine power loss is usually caused by fuel flow interruption and power will be restored shortly after fuel flow is restored. The first step is to prepare for a power off landing (refer to paragraph 3.13). An airspeed of at least 90 KIAS should be maintained.

If altitude permits, switch the fuel selector to another tank containing fuel and turn the auxiliary fuel pump on LOW. Reset the mixture control as required and move the induction air to ALTERNATE. Check the engine gauges for an indication of the cause of the power loss.

If power is restored move the induction air to the PRIMARY position (unless induction ice is suspected). Turn OFF the auxiliary fuel pump and adjust the mixture control as necessary.

If power is not restored within ten seconds, select auxiliary fuel pump switch to HIGH, mixture FULL RICH and throttle to approximately 75% power.

CAUTION

If normal engine operation and fuel flow is not immediately re-established, the auxiliary fuel pump should be turned OFF. The lack of fuel flow indication could indicate a leak in the fuel system.

If the preceding steps do not restore power, prepare for a power off landing.

If previous procedure has not restored power and time permits, place auxiliary fuel pump to LOW. Secure one mag at a time, then back to both ON. Move the throttle and mixture control levers to different settings. This may restore power if the problem is too rich or too lean a mixture or if there is a partial fuel system restriction. Water in the fuel could take some time to be used up, and allowing the engine to windmill may restore power. If power loss is due to water, fuel flow indications will be normal.

If engine failure was caused by fuel exhaustion, power will not be restored after switching fuel tanks until the empty fuel lines are filled. This may require up to ten seconds.

If power is not regained, proceed with the Power Off Landing procedure (refer to paragraph 3.13).

CAUTION

The auxiliary fuel pump has no standby function. Actuation of the HIGH switch position after the engine is operating normally will cause engine roughness and/or power loss. If the auxiliary fuel pump switch or primer switch fails causing the auxiliary fuel pump to be activated in the HIGH mode while the engine driven fuel pump is operating normally, engine roughness and or/power loss will occur. Should this condition exist pull out the L. FUEL or R. FUEL pull-type circuit breaker for the selected fuel tank.

3.13 POWER OFF LANDING

If loss of power occurs at altitude, trim the aircraft for best gliding angle, (90 KIAS) and look for a suitable field. If measures taken to restore power are not effective, and if time permits, check your charts for airports in the immediate vicinity; it may be possible to land at one if you have sufficient altitude. At best gliding angle, with no wind, with the engine windmilling and the propeller control in full DECREASE rpm, the aircraft will travel approximately 2 miles for each thousand feet of altitude. If possible, notify the FAA or any other authority by radio of your difficulty and intentions. If another pilot or passenger is aboard, let him help.

When you have located a suitable field, establish a spiral pattern around this field. Try to be at 1000 feet above the field at the downwind position, to make a normal landing approach. When the field can easily be reached, slow to 77 KIAS with flaps down for the shortest landing. Excess altitude may be lost by widening your pattern, using flaps or slipping, or a combination of these.

Whether to attempt a landing with gear up or down depends on many factors. If the field chosen is obviously smooth and firm, and long enough to bring the plane to a stop, the gear should be down. If there are stumps or rocks or other large obstacles in the field, the gear in the down position will better protect the occupants of the aircraft. If however, the field is suspected to be excessively soft or short, or when landing in water of any depth, a wheels-up landing will normally be safer and do less damage to the airplane.

Touchdowns should normally be made at the lowest possible airspeed with flaps as required.

When committed to landing, verify the landing gear selector position as required by field conditions. Close the throttle, move the mixture to idle cut-off, and shut OFF the magneto switches. Move the fuel selector valve to OFF. After final flap setting, turn the battery and alternator switch(es) OFF. The seat belts and shoulder harness (if installed) should be tightened.

NOTE

If the battery and alternator switch(es) are OFF, the gear position lights and flaps will be inoperative.

3.15 FIRE IN FLIGHT

The presence of fire is noted through smoke, smell and heat in the cabin. It is essential that the source of the fire be promptly identified through instrument readings, character of smoke, or other indications since the action to be taken differs somewhat in each case.

Check for the source of the fire first.

If an electrical fire is indicated (smoke in cockpit), activate the cabin dump switch and PULL the cabin pressurization control to clear the smoke. After a delay of 5 seconds the battery and alternator switches and the cabin heat should be turned OFF.

CAUTION

The dump valve will remain open if activated prior to turning the aircraft electrical system OFF. This provides maximum airflow through the cabin for smoke evacuation. Do not turn the cabin dump switch OFF. The dump valve will close and cannot be reactivated unless electrical power is turned ON.

An emergency descent should be executed to an altitude of 12,500 feet or less and a landing made as soon as possible.

WARNING

If emergency oxygen is installed, use ONLY if flames and heat are not present.

If an engine fire is present, close the throttle, move the mixture control to idle cut-off and place the fuel selector in the OFF position. Turn the magneto switches OFF and check that the auxiliary fuel pump is OFF. In all cases, the heater and defroster should be OFF. If radio communication is not required turn the battery and alternator switch(es) OFF. If the terrain permits, a landing should be made immediately. Remember the flaps and landing gear position lights become inoperative with the battery and alternator switch(es) OFF. Ensure battery and alternator switch(es) are OFF after final flap and gear selection is made.

NOTE

The possibility of an engine fire in flight is extremely remote. The procedure given is general and pilot judgment should be the determining factor for action in such an emergency.

3.17 LOSS OF OIL PRESSURE

Loss of oil pressure may be either partial or complete. A partial loss of oil pressure usually indicates a malfunction in the oil pressure regulating system, and a landing should be made as soon as possible to investigate the cause and prevent engine damage.

A complete loss of oil pressure indication may signify oil exhaustion or may be the result of a faulty gauge. In either case, proceed toward the nearest airport and be prepared for a forced landing. If the problem is not a pressure gauge malfunction, the engine may stop suddenly. Maintain altitude until such time as a power off landing can be accomplished. Do not change power settings unnecessarily, as this may hasten complete power loss.

Depending on the circumstances, it may be advisable to make an off airport landing while power is still available, particularly if other indications of actual oil pressure loss, such as sudden increases in temperatures, or oil smoke, are apparent, and an airport is not close.

If engine stoppage occurs, proceed with Power Off Landing procedure (refer to paragraph 3.13).

3.19 LOSS OF FUEL FLOW

The most probable cause of loss of fuel flow is either fuel depletion in the fuel tank selected or failure of the engine driven fuel pump. If loss of fuel flow occurs, turn the auxiliary fuel pump on LOW and check that the fuel selector is on a tank containing usable fuel.

If power is restored, turn OFF the auxiliary fuel pump and adjust the mixture control as necessary.

If power is not restored within ten seconds, select auxiliary fuel pump switch to HIGH, mixture FULL RICH and throttle to approximately 75% power.

CAUTION

If normal engine operation and fuel flow is not immediately re-established, the auxiliary fuel pump should be turned OFF. The lack of a fuel flow indication could indicate a leak in the fuel system.

If loss of fuel flow is due to failure of the engine driven fuel pump the HIGH position of the auxiliary fuel pump will supply sufficient fuel flow for approximately 75% power or less. Adjust the throttle and mixture as required for smooth engine operation.

3.21 ENGINE DRIVEN FUEL PUMP FAILURE

If an engine driven fuel pump failure is indicated, retard the throttle and turn the auxiliary fuel pump on HIGH. The throttle and mixture should then be reset as required. The HIGH position of the auxiliary fuel pump will supply fuel flow for approximately 75% power or less. A landing should be made at the nearest appropriate airport as soon as possible and the cause of the failure investigated.

CAUTION

If normal engine operation and fuel flow is not immediately re-established, the aux. fuel pump should be turned OFF. The lack of a fuel flow indication could indicate a leak in the fuel system.

3.23 HIGH OIL TEMPERATURE

An abnormally high oil temperature indication may be caused by a low oil level, an obstruction in the oil cooler, damaged or improper baffle seals, a defective gauge, or other causes. Land as soon as practical at an appropriate airport and have the cause investigated.

A steady rapid rise in oil temperature is a sign of trouble. Land at the nearest airport and let a mechanic investigate the problem. Watch the oil pressure gauge for an accompanying loss of pressure.

3.25 HIGH CYLINDER HEAD TEMPERATURE

Excessive cylinder head temperature may parallel excessive oil temperature. In any case, reduce power and/or enrich the mixture as necessary. If the problem persists, land as soon as practical at an appropriate airport and have the cause investigated. Do not operate in cruise with a mixture setting other than 50° lean of peak T.I.T.

3.26 TURBINE INLET TEMPERATURE (TIT) INDICATOR FAILURE

CAUTION

Aircraft POH range and endurance data presented in Section 5 will no longer be applicable. Less range/endurance will result due to higher fuel flow/fuel consumption.

If TIT indication fails during takeoff, climb, descent or landing, maintain FULL RICH mixture to assure adequate fuel flow for engine cooling.

If TIT indication fails after cruise power has been set, maintain cruise power setting and lean to 6 GPH fuel flow above that specified in the Power Setting Table in Section 5 of this handbook. Continually monitor engine cylinder head and oil temperatures to avoid exceeding limits.

The TIT indicating system must be repaired as soon as possible after failure has occurred.

Continued operation with failed TIT indication is not authorized.

3.27 ELECTRICAL FAILURES

CAUTION

The alternator output circuit breakers should never be opened manually when the alternators are functioning properly, as voltage regulator damage may occur.

Loss of alternator output is detected through zero reading on the ammeter and illumination of the ALTERNATOR annunciator light. Before executing the following procedure, ensure that the reading is zero and not merely low by momentarily actuating an electrically powered device, such as the taxi lights. If no increase in the ammeter reading is noted, alternator failure can be assumed.

The electrical load should be reduced as much as possible. Check the ALTNR circuit breakers for an open circuit.

The next step is to attempt to reset the alternator control unit. This is accomplished by moving the ALTR switch to OFF for one second and then to ON. If the trouble was caused by a momentary overvoltage condition (32 volts and up) this procedure should return the ammeter to a normal reading.

If the ammeter continues to indicate zero output, or if the alternator will not remain reset, the course of action depends on the alternator system installed.

If the aircraft is equipped with a single alternator, turn OFF the ALTR switch. Turn the battery switch OFF and turn the EMER BUS switch ON. Activation of the emergency bus switch will allow the use of the minimum equipment necessary to operate the aircraft and will provide maximum flight time prior to battery depletion. (Refer to the Electrical Schematics in Section 7 for a list of electrical equipment supplied by the emergency bus.) Land as soon as practical. All electrical load is being supplied by the battery.

If the aircraft is equipped with dual alternators, turn OFF the ALTR switch of the affected alternator, insure electrical loads are below 60 amps, and continue the flight. Monitor the ammeter of the operating alternator since the ALTERNATOR annunciator light will remain on. The ammeter is the only indication of the condition of the remaining alternator.

3.29 ELECTRICAL OVERLOAD (Alternator more than 20 amps above known electrical load)

If abnormally high alternator output is observed (more than 20 amps above known electrical load for the operating conditions) it may be caused by a low battery, a battery fault or other abnormal electrical load. If the cause is a low battery, the indication should begin to decrease toward normal within 5 minutes.

If the overload condition persists, use the following procedure to determine the probable cause and appropriate action to be taken.

- (a) Reduce the electrical load as much as possible. If equipped with dual alternators ensure that the total load is less than 60 amps.
- (b) If the aircraft is equipped with dual alternators, turn the ALTR No. 1 switch OFF and turn the volt/ammeter selector switch to monitor alternator No. 2.

NOTE

The alternator annunciator light will be illuminated when either ALTR switch is in the OFF position.

- (c) Ensure that the ALTR No. 1 switch is ON for single alternator equipped aircraft or that the ALTR No. 2 switch is on for dual alternator aircraft. Turn the battery switch OFF.
- (1) If the ammeter indication decreases, a battery fault is indicated. Turn the battery switch ON and continue to monitor the ammeter. If the alternator output does not decrease within 5 minutes, turn the battery switch OFF, turn the ALTR No. 1 switch ON if equipped with dual alternators and land as soon as practical. All electrical loads are being supplied by the alternator(s).

NOTE

Due to higher voltage and radio frequency noise, operation with the ALTR switch(es) ON and the battery switch OFF should be made only when required by an electrical failure.

- (2) If the ammeter indication does not decrease when the battery switch is turned OFF, an alternator fault is indicated. If the aircraft is equipped with a single alternator, turn the ALTR No. 1 switch OFF and the battery switch OFF and turn the EMER BUS switch ON. Activation of the emergency bus switch will allow the use of the minimum equipment necessary to operate the aircraft and will provide maximum flight time prior to battery depletion. Refer to the Electrical Schematics in Section 7 for a list of equipment supplied by the emergency bus. All electrical loads are being supplied by the battery. If the aircraft is equipped with dual alternators, turn the battery switch ON, the ALTR No. 2 switch OFF and the ALTR No. 1 switch ON. If the overload condition is not present, the fault is in the No. 2 alternator. Continue the flight with the ALTR No. 2 switch OFF. If the overload condition persists, turn both ALTR switches OFF and the battery switch OFF and turn the EMER BUS switch ON. All electrical loads are being supplied by the battery. Land as soon as possible.

NOTE

If the battery is depleted, the landing gear must be lowered using the emergency extension procedure. The gear position lights will be inoperative and a flaps up landing will be required.

3.31 PROPELLER OVERSPEED

Propeller overspeed is caused by a malfunction in the propeller governor or low oil pressure which allows the propeller blades to rotate to full low pitch.

If propeller overspeed should occur, retard the throttle and check the oil pressure. The prop control should be moved to full DECREASE rpm and then reset if any control is available. Airspeed should be reduced and throttle used to maintain 2600 RPM.

3.33 EMERGENCY LANDING GEAR EXTENSION

Prior to proceeding with an emergency gear extension, check to ensure that the battery switch is ON and that the circuit breakers have not popped. If it is daytime, the Day/Night dimmer switch should be in the DAY position.

If the landing gear does not check down and locked, reduce the airspeed to below 90 KIAS, pull out the HYD PUMP circuit breaker, place the landing gear selector in the DOWN position, pull the emergency gear extend control OUT and fishtail the airplane. Verify the landing gear position lights indicate down and locked.

CAUTION

The emergency gear extension procedure will require the pilot to pull the emergency gear extend control knob through a region of high resistance (up to 25 pounds) in order to reach the stop and extend the landing gear.

If all electrical power has been lost, the landing gear must be extended using the above procedures. The gear position indicator lights will not illuminate.

3.35 SPIN RECOVERY

Intentional spins are prohibited in this airplane. If a spin is inadvertently entered, immediately apply full rudder opposite to the direction of rotation. Move the control wheel full forward while neutralizing the ailerons. CLOSE the throttle. When the rotation stops, neutralize the rudder and relax forward pressure on the control wheel as required to smoothly regain a level flight attitude.

3.37 ENGINE ROUGHNESS

Engine roughness may be caused by dirt in the injector nozzles, induction filter icing, ignition problems, or other causes.

First adjust the mixture for maximum smoothness. The engine will run rough if the mixture is too rich or too lean.

Move the induction air to ALTERNATE and turn the auxiliary fuel pump on LOW.

Switch the fuel selector to another tank to determine if fuel contamination is the problem.

Check the engine gauges for abnormal readings. If any gauge readings are abnormal proceed accordingly.

The magneto switches should then be turned OFF individually and then both turned back ON. If operation is satisfactory on either magneto, proceed on that magneto at reduced power to a landing at the first available airport.

If roughness persists, prepare for a precautionary landing at pilot's discretion.

3.39 EMERGENCY DESCENT

NOTE

If pressurized, the following procedure will result in the immediate loss of pressurization and the cabin altitude will rise at an uncontrolled rate.

In the event an emergency descent becomes necessary, the seat belts and shoulder harnesses should be snugged down securely, retard the throttle to idle and move the prop control to the full INCREASE position. The mixture should be reset as required to ensure the engine will continue operating. Lower the landing gear and immediately initiate a descent. If in smooth air,

descend at 180 to 200 KIAS maximum. If extremely rough air is encountered, the airspeed should be limited according to the following airspeed versus Gross Weight Table:

4100 lbs.— 135 KIAS
2450 lbs. — 103 KIAS

After reaching a safe altitude, advance the throttle and adjust mixture and prop controls for power as required.

3.41 PRESSURIZATION SYSTEM MALFUNCTION

Should the differential pressure rise above 5.5 psi maximum or a structural failure appear imminent, an immediate decrease in differential pressure is required. To accomplish this, activate the cabin dump switch and PULL the cabin pressurization control. This will cause the cabin altitude to rise at an uncontrolled rate and cabin differential pressure to decrease, subsequently relieving the over-pressure condition. If emergency oxygen is not installed execute an emergency descent to 12,500 feet or below. If emergency oxygen is installed, don the oxygen masks, activate the oxygen generators and descend to an altitude of 12,500 feet or below.

Should the aircraft suddenly lose pressurization, check that the cabin dump switch has not been activated and that the cabin pressurization control is pushed in. If the aircraft does not begin to re-pressurize and emergency oxygen is not installed, execute an emergency descent to 12,500 feet or below. If emergency oxygen is installed, don the oxygen masks, activate the oxygen generators and descend to an altitude of 12,500 feet or below.

3.43 CABIN AIR CONTAMINATION/SMOKE EVACUATION

Strong fumes or smoke in the cabin may indicate a malfunction in the pressurization system or a fire. In any event, the primary concern is to establish maximum airflow through the cabin in order to vent the fumes or smoke. To accomplish this, actuate the cabin dump switch and PULL the cabin pressurization control out. Turn ON the vent/defog fan and turn OFF the cabin air recirculation fan. Do not open the storm window. This procedure will provide the maximum flow of outside ram air through the cabin. If

emergency oxygen is not installed, execute an emergency descent to an altitude of 12,500 feet or less. If emergency oxygen is installed, don the oxygen masks, activate the oxygen generators and descend to an altitude of 12,500 feet or below. If the fumes or smoke have disappeared after reaching 12,500 feet, a pressurization malfunction can be assumed. Land as soon as practical and investigate the cause. If the fumes or smoke persist the problem may be a fire (see paragraph 3.15, Fire In Flight).

3.45 GYRO SUCTION FAILURE (Suction below 4.8 in. Hg.) (Aircraft not equipped with stand-by vacuum pump)

A malfunction of the instrument suction will be indicated by a reduction of the suction reading on the gage..

In the event of a suction system malfunction during unpressurized flight, turn the cabin dump switch OFF, push the cabin pressurization control IN and select a cabin altitude to maintain at least 2.3 PSID. During pressurized flight select a cabin altitude to maintain at least 2.3 PSID.

Monitor the electrical directional gyro.

3.47 INADVERTENT ICING ENCOUNTER OR FLIGHT IN SNOW

WARNING

Flight into known icing conditions is prohibited unless Ice Protection System is installed and operable. Refer to Section 9, Supplement 10.

If icing conditions or snow are inadvertently encountered, turn the pitot heat ON. Set the cabin heat control to maximum and turn ON the windshield defrost and vent/defog fan to keep the windshield as clear as possible. Change aircraft heading and/or altitude to exit icing conditions or snow as soon as possible. If a loss of manifold pressure occurs, select ALTERNATE induction air and adjust manifold pressure as required.

3.48 HYDRAULIC SYSTEM MALFUNCTION

A hydraulic system malfunction, which causes the hydraulic pump to either run continuously (more than 15-20 seconds), or cycle on and off rapidly (more than 6-8 times), may be detected by the illumination of the HYD PUMP amber annunciator light. Pull the HYD PUMP circuit breaker to stop operation. The pump is not designed for continuous duty and will fail if left running. Land as soon as possible and investigate the cause. It may be necessary to lower the landing gear using the emergency extension control.

3.49 FLAP SYSTEM MALFUNCTION

Illumination of the FLAPS annunciator would normally be the result of an overcurrent condition in the flap motor/actuator circuit. If an overcurrent fault occurs the flap protection circuit will sense the malfunction and automatically remove power from the flap motor/actuator and flap operation will stop. Pulling and resetting the FLAP WARN/RESET circuit breaker will restore flap power to normal operation.

After resetting, normal operation of the flaps should be verified.

If normal flap operation is not regained, or the FLAPS annunciator remains illuminated, pull the FLAP MOTOR circuit breaker and land as soon as possible to ascertain the cause of the problem. The flaps will remain in the same position as when the malfunction occurred.

TABLE OF CONTENTS
SECTION 4
NORMAL PROCEDURES

Paragraph No.		Page No.
4.1	General	4-1
4.3	Airspeeds for Safe Operations.....	4-1
4.5	Normal Procedures Checklist.....	4-3
	Preflight Check.....	4-3
	Before Starting Engine	4-7
	Starting Engine	4-7
	Starting Engine When Flooded	4-8
	Starting With External Power Source.....	4-8
	Warm-Up	4-9
	Taxiing	4-9
	Ground Check.....	4-10
	Before Takeoff	4-10
	Takeoff.....	4-11
	Takeoff Climb.....	4-12
	Cruise Climb.....	4-12
	Cruising	4-12
	Descent	4-13
	Approach And Landing	4-13
	Go-Around.....	4-14
	Stopping Engine	4-14
	Parking.....	4-14
4.7	Amplified Normal Procedures (General)	4-15
4.9	Preflight Check.....	4-15
4.11	Before Starting Engine	4-18
4.13	Starting Engine	4-19

TABLE OF CONTENTS (cont)

SECTION 4 (cont)

Paragraph No.		Page No.
4.15	Warm-Up	4-21
4.17	Taxiing.....	4-22
4.19	Ground Check	4-22
4.21	Before Takeoff.....	4-23
4.23	Takeoff.....	4-24
4.25	Climb.....	4-26
4.27	Cruising	4-26
4.29	Descent	4-29
4.31	Approach and Landing.....	4-29
4.33	Go-Around	4-30
4.35	Stopping Engine	4-31
4.37	Parking.....	4-31
4.39	Stalls	4-31
4.41	Turbulent Air Operation.....	4-32
4.43	Landing Gear.....	4-32
4.45	Cabin Pressurization System.....	4-33
4.47	Weight and Balance.....	4-34
4.49	Icing Information.....	4-35

**SECTION 4
NORMAL PROCEDURES**

4.1 GENERAL

This section describes the recommended procedures for the conduct of normal operations for the airplane. All of the required (FAA regulations) procedures and those necessary for operation of the airplane as determined by the operating and design features of the airplane are presented.

Normal procedures associated with those optional systems and equipment which require handbook supplements are provided by Section 9 (Supplements).

These procedures are provided to present a source of reference and review and to supply information on procedures which are not the same for all aircraft. Pilots should familiarize themselves with the procedures given in this section in order to become proficient in the normal operations of the airplane.

The first portion of this section consists of a short form checklist which supplies an action sequence for normal operations with little emphasis on the operation of the systems.

The remainder of the section is devoted to amplified normal procedures which provide detailed information and explanations of the procedures and how to perform them. This portion of the section is not intended for use as an in-flight reference due to the lengthy explanation. The short form checklist should be used for this purpose.

4.3 AIRSPEEDS FOR SAFE OPERATIONS

The following airspeeds are those which are significant to the safe operation of the airplane. These figures are for standard airplanes flown at gross weight under standard conditions at sea level.

Performance for a specific airplane may vary from published figures depending upon the equipment installed, the condition of the engine, airplane and equipment, atmospheric conditions and piloting technique.

- (a) Best Rate of Climb Speed110 KIAS
- (b) Best Angle of Climb Speed90 KIAS
- (c) Turbulent Air Operating Speed (See Subsection 2.3)135 KIAS
- (d) Landing Final Approach Speed (Full Flaps)77 KIAS
- (e) Maximum Demonstrated Crosswind Velocity17 KTS
- (f) Maximum Flaps Extended Speed
 - 10°170 KIAS
 - 20°135 KIAS
 - Full Flaps (36°)120 KIAS

FOR REFERENCE ONLY
NOT FOR FLIGHT

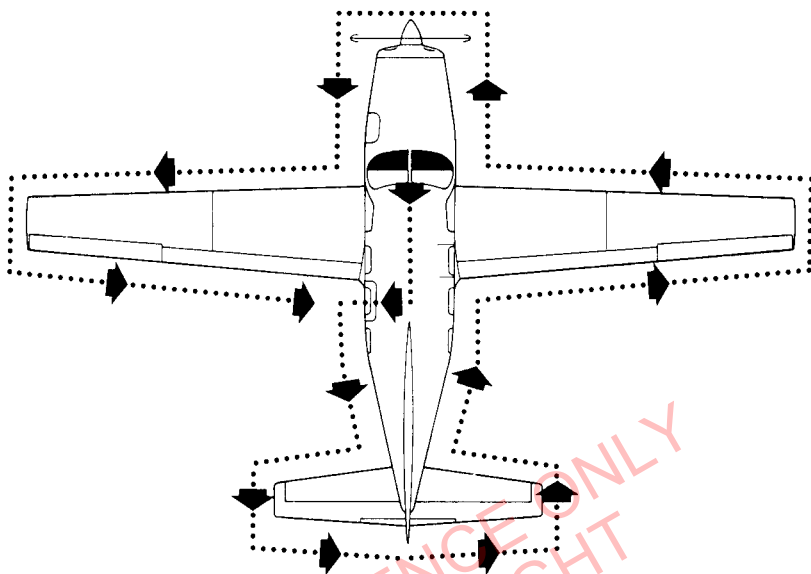

WALK-AROUND

Figure 4-1

4.5 NORMAL PROCEDURES CHECKLIST

PREFLIGHT CHECK

COCKPIT

- Control wheelrelease restraints
- Parking brakeset
- Gear handleDOWN
- All switchesOFF
- AvionicsOFF
- Mixtureidle cut-off
- Battery switch.....ON
- Fuel gaugescheck quantity
- Annunciator panel.....check
- Oxygen light (if installed).....check
- Flapsextend
- Battery switchOFF
- Primary flight controls.....proper operation

Trim.....neutral
Static systemdrain
Emergency exitcheck
Windows.....check clean
Required paperscheck on board
Baggagestow properly - secure

EMPENNAGE

Antennascheck
Surface conditionclear of ice, frost, snow
Left static portclear
Alternate static portclear
Elevatorcheck
Rudder.....check
Static wicks.....check
Tie down.....remove
Right static portclear

RIGHT WING

Surface conditionclear of ice, frost, snow
Flap and hingescheck
Aileron and hingescheck
Static wicks.....check
Wing tip and lights.....check
Fuel tank.....check supply
visually - secure cap
Fuel tank ventclear
Tie down and chock.....remove
Main gear strut.....proper
inflation (2.5 +/- .25 in.)
Tire.....check
Brake block and disc.....check
Fuel tank sump.....drain and check
for water, sediment
and proper fuel

CAUTION

When draining any amount of fuel, care should be taken to ensure that no fire hazard exists before starting engine.

NOSE SECTION

- General condition.....check
Fuel filter sump.....drain and check
for water, sediment
and proper fuel
Cowling.....secure
Windshield.....clean
Propeller and spinner.....check
Air inlets.....clear
Landing light.....check
Chock.....remove
Nose gear strut.....proper
inflation (1.5 +/- .25 in.)
Nose wheel tire.....check
Engine baffle seals.....check
Oil check quantity
Dipstick.....properly seated
Oil filler cap.....secure
Tow bar.....stow properly - secure
Baggage door.....close and secure
- LEFT WING**
- Surface condition.....clear of ice, frost, snow
Fuel tank sump.....drain and check
for water, sediment
and proper fuel

CAUTION

When draining any amount of fuel, care should be taken to ensure that no fire hazard exists before starting engine.

- Tie down and chock.....remove
Main gear strut.....proper
inflation (2.5 +/- .25 in.)
Tire.....check
Brake block and disc.....check
Pitot head.....holes clear
Fuel tank.....check supply
visually - secure cap
Fuel tank vent.....clear

Wing tip and lightscheck
Aileron and hingescheck
Static wickscheck
Flap and hingescheck

MISCELLANEOUS

Oxygen system (if installed)check masks and hoses
Battery switchON
Flapsretract
Interior lightingON and check
Pitot heat switchON

CAUTION

Care should be taken when an operational check of the heated pitot head is being performed. The unit becomes very hot. Ground operation should be limited to three minutes maximum to avoid damaging the heating elements.

Exterior lighting switchesON and check
Pitotcheck - warm
Stall warning horncheck
All lighting switchesOFF
Pitot heat switchOFF
Battery switchOFF
Passengersboard
Doorsclose and latch
Door pinsall indicators green

WARNING

Do not initiate any flight if all four door pin indicators are not green and/or the DOOR AJAR annunciator is lit.

Seat belts and harnessfasten/adjust
check inertia reel

BEFORE STARTING ENGINE

Parking brakeset

WARNING

No braking will occur if aircraft brakes are applied while parking brake handle is pulled and held.

Prop control.....full INCREASE
Fuel selector.....desired tank
RadiosOFF
Alternator(s)ON
Cabin altitude selectorset
Cabin altitude rate controlset
Cabin pressurization control.....set
Cabin dump switchset
Induction air.....check

STARTING ENGINE

Mixture.....full RICH
Throttlefull FORWARD
Prop control.....full INCREASE
Battery switch.....ON
Mag switches.....ON
Aux. fuel pump.....OFF
Primer.....ON

NOTE

The amount of prime required depends on engine temperature. Familiarity and practice will enable the operator to estimate accurately the amount of prime to use. If the engine is hot, use prime pump only long enough to purge fuel system of accumulative vapor.

CAUTION

The STARTER ENGAGED annunciator will illuminate during engine cranking. If the annunciator remains lit after the engine is running, stop the engine and determine the cause.

Throttle1/2" to 3/4" OPEN
Starter.....engage immediately
At temperatures below +20°F continue priming while cranking until engine starts.

When engine starts firing, open throttle very slowly to raise engine speed to 1000 RPM. As engine speed accelerates through 500 RPM, release starter.

Aux. fuel pump.....low only as necessary
to obtain smooth engine
operation (1-3 minutes
will be required when
temp. is below 20°F)

Oil presscheck
Alternator(s).....check
Gyro suction.....check

STARTING ENGINE WHEN FLOODED

Mixtureidle cut-off
Throttle.....full FORWARD
Prop control.....full INCREASE
Battery switch.....ON
Aux. fuel pumpOFF
Propellerclear
Starter.....engage

When engine fires:

Throttleretard
Mixtureadvance slowly
Oil pressurecheck

STARTING WITH EXTERNAL POWER SOURCE

Battery switchOFF
Alternator(s).....OFF
All electrical equipment.....OFF
Terminalsconnect
External power plug.....insert in receptacle

Proceed with normal start

CAUTION

Care should be exercised because if the ship's battery has been depleted, the external power supply can be reduced to the level of the ship's battery. This can be tested by turning the battery switch ON momentarily while the starter is engaged. If cranking speed increases, the ship's battery is at a higher level than the external power supply.

- Throttlelowest possible RPM
- External power plugdisconnect from receptacle
- Baggage doorclosed and secure
- Battery switch.....ON
- Alternator(s).....ON - check ammeter
- Oil pressurecheck

WARM-UP

CAUTION

Do not operate engine above 1200 RPM with cabin doors open.

- Throttle1000 to 1200 RPM

TAXIING

- Chocks.....removed
- Parking brakereleased
- Taxi areaclear
- Prop control.....full INCREASE
- Throttleapply slowly
- Brakescheck
- Steeringcheck

GROUND CHECK

CAUTION

Alternate air is unfiltered. Use of alternate air during ground or flight operations, when dust or other contaminants are present, may result in engine damage from particle ingestion.

- Parking brakeset
- Prop control.....full INCREASE
- Throttle2000 RPM
- Magnetosmax. drop 150 RPM
- max. diff. 50 RPM
- Gyro suction.....4.8 to 5.2 in. Hg.
- Stand-by vacuum pumpcheck

NOTE

If flight into icing conditions (in visible moisture below +5°C) is anticipated, conduct a preflight check of the icing systems per Supplement No. 10 - Ice Protection System.

- Ice protection equipment.....CHECK AS REQUIRED
- Volt/ammeter.....check
- Oil temp.check
- Oil pressure.....check
- Propeller.....exercise - then
full INCREASE
- Throttleretard
- Air conditioner.....check
- Annunciator panel.....press-to-test
- Manifold pressure linedrain

BEFORE TAKEOFF

- Battery switch.....ON
- Alternator(s)ON
- Pressurization controls.....set
- Flight instrumentscheck
- Fuel selector.....proper tank

Aux. fuel pumpOFF
Engine gaugescheck
Induction airPRIMARY

NOTE

If flight into icing conditions (in visible moisture below +5°C) is anticipated, conduct a preflight check of the icing systems per Supplement No. 10 - Ice Protection System.

Pitot heatAS REQUIRED
Stall warning heatAS REQUIRED
Wshld heatAS REQUIRED
Prop heatAS REQUIRED
Seat backserect
Seatsadjusted & locked in position
Mixturefull RICH
Prop controlfull INCREASE
Belts/harnessfastened/adjusted
Empty seatsseat belts snugly fastened
Flapsset
Trimset
Controlsfree
Doorlatched
Air conditionerOFF
Parking brakereleased

TAKEOFF

NORMAL

Flapsset
Trimset
Throttlefull power

WARNING

If flight into icing conditions (visible moisture below +5°C) is anticipated or encountered during climb, cruise or descent, activate the aircraft ice protection system including the pitot heat, as described in supplement No. 10 - Ice Protection System.

Accelerate to 77 KIAS

Control wheelback pressure to
rotate to climb attitude

SHORT OR SOFT FIELD, OBSTACLE CLEARANCE

Flaps20°
Trimset
Throttlefull power prior to
brake release

NOTE

Takeoffs are normally made with full throttle. However, under some off standard conditions manifold pressure and/or fuel flow indications can exceed their indicated limits at full throttle. Limit manifold pressure to 38 in. Hg maximum. (See Section 7)

Accelerate to 70 KIAS.

Control wheelback pressure to
rotate to climb attitude

After breaking ground, accelerate to 74 KIAS.

GearUP

Accelerate to climb speed

FlapsUP

TAKEOFF CLIMB

NOTE

Power should be reduced to cruise climb setting after all obstacles are cleared.

Mixturefull RICH

Prop speed2600 RPM

Manifold pressurefull power

Climb speed

Best angle90 KIAS

Best rate110 KIAS

Aux. fuel pumpLOW - if required

Pressurization controlsset

CRUISE CLIMB

Mixture.....	full RICH
Prop speed.....	2500 RPM
Manifold pressure	35 in. Hg.
Climb speed	125 KIAS below 22,000 ft 115 KIAS above 22,000 ft
Aux. fuel pump	LOW - if required
Pressurization controls.....	set

CRUISING

WARNING

Operation above 25,000 ft is not approved.

NOTE

The cruise mixture must be set in strict accordance with the procedure outlined in the amplified procedures of this section. Failure to do so will result in excess fuel burn and reduced engine life.

NOTE

Maximum continuous T.I.T. is 1750°F. Temporary operation up to 1800°F is permitted in order to define peak T.I.T. In no case should the aircraft be operated more than 30 seconds with a T.I.T. in excess of 1750°F.

Reference Section 5 power setting table and performance charts.

Maximum cruise power	75%
Power	set per power table
Mixture.....	50 lean of peak T.I.T.
Aux. fuel pump	OFF
Pressurization controls.....	check

DESCENT

NORMAL

Powercruise
Mixture.....cruise setting
Gearas required
Airspeed.....as required
Pressurization controls.....set

REDUCED POWER

Mixture1500°F T.I.T.
Throttleabove 20 in. Hg.
Prop speed.....cruise setting
Pressurization controls.....set

APPROACH AND LANDING

Fuel selectorproper tank
Seat backserect
Belts/harnessfasten/adjust
Aux. fuel pumpOFF
Cabin pressuredepressurized
Mixtureset
Prop controlset
Geardown - 170 KIAS max.
Flaps.....set
Air conditioner.....OFF
Toe brakesdepress to check

WARNING

After pumping several times, if one or both toe
brakes are inoperative, DO NOT attempt
landing on a short field.

NORMAL TECHNIQUE

Flapsas required
Airspeed85 KIAS
Throttleas required

SHORT FIELD TECHNIQUE

Flapsfull DOWN
Airspeed77 KIAS
Throttle.....closed

GO-AROUND

Mixture.....full RICH
Prop control.....full INCREASE
Throttlefull power
Control wheelback pressure to
rotate to climb attitude
Airspeed80 KIAS
GearUP
Flapsretract slowly
Trimas required

STOPPING ENGINE

Flapsretract
Radios and electrical equipmentOFF
Air conditionerOFF
Prop control.....full INCREASE
ThrottleCLOSED
Mixtureidle cut-off
Magnetos.....OFF
Alternator(s).....OFF
Battery switchOFF

PARKING

Parking brakeset
Control wheelsecured with belts
Flapsfull up
Wheel chocks.....in place
Tie downssecure

THIS PAGE INTENTIONALLY LEFT BLANK

**FOR REFERENCE ONLY
NOT FOR FLIGHT**

4.7 AMPLIFIED NORMAL PROCEDURES (GENERAL)

The following paragraphs are provided to supply detailed information and explanations of the normal procedures necessary for operation of the airplane.

4.9 PREFLIGHT CHECK

The airplane should be given a thorough preflight and walk-around check. The preflight should include a check of the airplane's operational status, computation of weight and C.G. limits, takeoff distance and in-flight performance. A weather briefing should be obtained for the intended flight path, and any other factors relating to a safe flight should be checked before takeoff.

COCKPIT

Upon entering the cockpit, release the seat belts securing the control wheel. Set the parking brake by first depressing and holding the toe brake pedals and then pull the parking brake knob.

Check that the landing gear selector is in the DOWN position. Ensure that all electrical switches and the magneto switches are OFF. Turn OFF all avionics equipment (to save power and prevent wear on the units). The mixture should be in idle cut-off. Turn ON the battery switch, check the fuel quantity gauges for adequate supply and check that the annunciator panel illuminates. If the supplemental oxygen system is installed and its annunciator is lit, the expended canisters must be replaced if oxygen capability is desired for the flight. Extend the flaps for the walk-around inspection. Turn OFF the battery switch. Check the primary flight controls and flaps for proper operation and set the trim to neutral. Open the static system drain to remove any moisture that has accumulated in the lines. Check that the emergency exit is in place and securely latched. Check the windows for cleanliness and that the required papers are on board. Properly stow any baggage and secure.

EMPENNAGE

Begin the walk-around at the left side of the aft fuselage. Check the condition of any antennas located on the fuselage. All surfaces of the empennage must be clear of ice, frost, snow or other extraneous substances. Fairings and access covers should be attached properly. Ensure that the

primary airspeed system static ports on the left and right side of the aft fuselage and the alternate static port on the underside of the aft fuselage are clear of obstructions. The elevator and rudder should be operational and free from damage or interference of any type. Elevator and rudder static wicks should be firmly attached and in good condition. Check the condition of the tab and ensure that all hinges and push rods are sound and operational. If the tail has been tied down, remove the tie down rope.

RIGHT WING

Check that the wing surface and control surfaces are clear of ice, frost, snow or other extraneous substances. Check the flap, aileron and hinges for damage and operational interference. Static wicks should be firmly attached and in good condition. Check the wing tip and lights for damage.

Open the fuel cap and visually check the fuel color. The quantity should match the indication that was on the fuel quantity gauge. Replace cap securely. The fuel tank vent should be clear of obstructions.

Remove the tie down and chock.

Next, complete a check of the landing gear. Check the gear strut for proper inflation. There should be 2.5 +/- .25 inches of strut exposure under a normal static load. Check the tire for cuts, wear, and proper inflation. Make a visual check of the brake block and disc.

Drain the fuel tank sump through the quick drain located on the lower surface of the wing just inboard of the gear well, making sure that enough fuel has been drained to ensure that all water and sediment is removed. The fuel system should be drained daily prior to the first flight and after each refueling.

CAUTION

When draining any amount of fuel, care should be taken to ensure that no fire hazard exists before starting engine.

NOSE SECTION

Check the general condition of the nose section; look for oil or fluid leakage and that the cowling is secure. Drain the fuel filter sump located on the lower fuselage aft of the cowling. Check the windshield and clean if

necessary. The propeller and spinner should be checked for detrimental nicks, cracks, or other defects. The air inlets should be clear of obstructions. The landing light should be clean and intact.

Remove the chock and check the nose gear strut for proper inflation. There should be 1.5 +/- 0.25 inches of strut exposure under a normal static load. Check the tire for cuts, wear, and proper inflation. Check the engine baffle seals. Check the oil level; maximum endurance flights should begin with 8 quarts of oil. Make sure that the dipstick has been properly seated and that the oil filler cap has been properly secured. Ensure that the tow bar is secured in the nose baggage area.

Close and secure the nose baggage door.

LEFT WING

The wing surface should be clear of ice, frost, snow, or other extraneous substances. Drain the left fuel tank sump in the same manner as the right wing. Remove the tie down and chock. Check the main gear strut for proper inflation: there should be 2.5 +/- 0.25 inches of strut exposure under a normal static load. Check the tire and the brake block and disc.

If installed, remove the cover from the pitot head on the underside of the wing. Make sure the holes are open and clear of obstructions.

Open the fuel cap and visually check the fuel color. The quantity should match the indication that was on the fuel quantity gauge. Replace cap securely. The fuel tank vent should be clear of obstructions.

Check the wing tip and lights for damage. Check the aileron, flap, and hinges for damage and operational interference and that the static wicks are firmly attached and in good condition.

MISCELLANEOUS

Enter the cockpit and check oxygen masks and hoses if oxygen system is installed.

Turn the battery switch ON and retract the flaps. Check the interior lights by turning ON the necessary switches. After the interior lights are checked, turn ON the pitot heat switch and the exterior light switches. Next, perform a walk-around check on the exterior lights and check the heated pitot head for proper heating.

CAUTION

Care should be taken when an operational check of the heated pitot head is being performed. The unit becomes very hot. Ground operation should be limited to three minutes maximum to avoid damaging the heating elements.

Check the stall warning horn by raising the lift detector slightly and listening for the horn to sound.

Reenter the cockpit and turn all switches OFF. When all passengers are on board, the pilot should check that the cabin door is properly closed and latched, and visually check that all four door pin indicators are green.

WARNING

Do not initiate any flight if all four door pin indicators are not green and/or the DOOR AJAR annunciator is lit.

Seat belts on empty seats should be snugly fastened. All passengers should fasten their seat belts and shoulder harnesses. A pull test of the inertia reel locking restraint feature should be performed.

4.11 BEFORE STARTING ENGINE

WARNING

No braking action will occur if aircraft brakes are applied while parking brake handle is pulled and held.

Before starting the engine, the parking brake should be set and the prop control moved to the full INCREASE position. The fuel selector should then be moved to the desired tank. Check to make sure all the circuit breakers are in and the radios are OFF. Turn the alternator switch(es) ON.

If the flight is to be made unpressurized, the cabin pressurization control should be pulled out to dump bleed air overboard and the cabin dump switch should be ON in order to provide maximum cabin airflow. If pressurization is to be used during the flight, set the cabin altitude selector to 1000 feet

above the field elevation and the cabin altitude rate control to the 9 o'clock position. The cabin pressurization control must be pushed in and the cabin dump switch must be OFF.

Check induction air control for freedom of movement by moving lever to ALTERNATE and back to PRIMARY.

4.13 STARTING ENGINE

(a) Normal Starting

Advance the mixture to full RICH and the throttle and prop controls to full FORWARD. Turn the battery switch and the magneto switches ON. The auxiliary fuel pump should be OFF. Push primer switch and hold for the required priming time. Retard throttle to 1/2" to 3/4" OPEN and immediately engage starter. With ambient temperatures above +20°F, starts may be made by discontinuing priming before engaging starter.

NOTE

The amount of prime required depends on engine temperature. Familiarity and practice will enable the operator to estimate accurately the amount of prime to use. If the engine is hot, use prime pump only long enough to purge fuel system of accumulative vapor.

CAUTION

The STARTER ENGAGED annunciator will illuminate during engine cranking. If the annunciator remains lit after the engine is running, stop the engine and determine the cause.

With ambient temperatures below +20°F, starts should be made by continuing to prime during cranking period. Do not release starter until engine accelerates through 500 RPM, then SLOWLY advance throttle to obtain 1000 RPM. Release primer and immediately place auxiliary fuel pump switch to LOW. Auxiliary fuel pump operation will be required for one to three minutes during initial engine warm-up when temperature is below 20°F.

If oil pressure is not indicated within thirty seconds, stop the engine and determine the trouble.

NOTE

When cold weather engine starts are made without the use of engine preheating (refer to TCM Operator's Manual), longer than normal elapsed time may be required before an oil pressure indication is observed.

Check the volt/ammeter for indication of alternator output and the gyro suction gauge for positive indication.

(b) Starting Engine When Flooded

If an engine is flooded, move the mixture control to idle cut-off and advance the throttle and prop controls full forward. Turn ON the battery switch and magneto switches. The auxiliary fuel pump should be OFF. After ensuring that the propeller is clear, engage the starter. When the engine fires, retard the throttle and advance the mixture slowly. Check for positive indication of oil pressure.

(c) Starting Engine With External Power Source

An optional feature allows the operator to use an external battery to crank the engine without having to gain access to the airplane's battery.

Turn the battery and alternator switches OFF and turn all electrical equipment OFF. Connect the RED lead of the jumper cable to the POSITIVE (+) terminal of an external 24-volt battery and the BLACK lead to the NEGATIVE (-) terminal. Insert the plug of the jumper cable into the socket located inside the forward baggage door. Note that when the plug is inserted, the electrical system is ON. Proceed with the normal starting technique.

After the engine has started, reduce power to the lowest possible RPM to reduce sparking, disconnect the jumper cable from the aircraft and secure the baggage door. Turn the battery and alternator switches ON and check for an indication of output. **DO NOT ATTEMPT FLIGHT IF THERE IS NO INDICATION OF ALTERNATOR OUTPUT.**

NOTE

For all normal operations using the jumper cables, the battery switch should be OFF, but it is possible to use the ship's battery in parallel by turning the battery switch ON. This will give longer cranking capabilities, but will not increase the amperage.

CAUTION

Care should be exercised because if the ship's battery has been depleted, the external power supply can be reduced to the level of the ship's battery. This can be tested by turning the battery switch ON momentarily while the starter is engaged. If cranking speed increases, the ship's battery is at a higher level than the external power supply.

When the engine is firing evenly, advance the throttle to 1000 RPM. If oil pressure is not indicated within thirty seconds, stop the engine and determine the trouble. In cold weather it will take a few seconds longer to get an oil pressure indication.

Starter manufacturers recommend that cranking periods be limited to thirty seconds with a two minute rest between cranking periods. Longer cranking periods will shorten the life of the starter.

4.15 WARM-UP

CAUTION

Do not operate engine above 1200 RPM with cabin doors open.

Warm up the engine at 1000 to 1200 RPM. Avoid prolonged idling at low RPM, as this practice may result in fouled spark plugs.

Takeoff may be made as soon as the ground check is completed and the engine is warm.

Do not operate the engine at high RPM when running up or taxiing over ground containing loose stones, gravel or any loose material that may cause damage to the propeller blades.

4.17 TAXIING

Before attempting to taxi the airplane, ground personnel should be instructed and approved by a qualified person authorized by the owner. Ascertain that the propeller back blast and taxi areas are clear.

Release the parking brake by first depressing and holding the toe brake pedals and then push in on the parking brake knob. Power should be applied slowly to start the taxi roll. Taxi a few feet forward and apply the brakes to determine their effectiveness. Taxi with the prop control set to full INCREASE. While taxiing, make slight turns to ascertain the effectiveness of the steering.

Observe wing clearances when taxiing near buildings or other stationary objects. If possible, station an observer outside the airplane.

Avoid holes and ruts when taxiing over uneven ground.

Do not operate the engine at high RPM when taxiing over ground containing loose stones, gravel or any loose material that may cause damage to the propeller blades.

4.19 GROUND CHECK

CAUTION

Alternate air is unfiltered. Use of alternate air during ground or flight operations when dust or other contaminants are present may result in damage from particle ingestion.

Set the parking brake. The magnetos should be checked at 2000 RPM with the prop control set at full INCREASE. Drop off on either magneto should not exceed 150 RPM and the difference between the magnetos should not exceed 50 RPM. Operation on one magneto should not exceed 10 seconds.

NOTE

If flight into icing conditions (in visible moisture below +5°C) is anticipated, conduct a preflight check of the icing systems per Supplement No. 10 - Ice Protection System.

Check the suction gauge; the indicator should read 4.8 to 5.2 in. Hg at 2000 RPM. If the aircraft is equipped with dual vacuum pumps check that the left side red flow button is pulled in. Turn the STANDBY VAC pump switch ON and observe that the right side red flow button is pulled in to verify proper operation of the standby system. Turn the STANDBY VAC pump switch OFF for normal operations. Conduct a preflight check of the ice protection systems for proper operation.

Check the volt/ammeter for proper voltage and alternator output(s). Check oil temperature and oil pressure. The temperature may be low for some time if the engine is being run for the first time of the day.

The propeller control should be moved through its complete range to check for proper operation and then placed in full INCREASE rpm for takeoff. Do not allow a drop of more than 500 RPM during this check. In cold weather, the propeller control should be cycled from high to low RPM at least three times before takeoff to make sure that warm engine oil has circulated.

Retard the throttle and check the annunciator panel lights with the press-to-test button. Check the operation of the air conditioner if installed.

Drain the manifold pressure line by running the engine at 1000 RPM and depressing the drain valve, located on the left side of the control pedestal under the instrument panel, for 5 seconds. Do not depress the valve when the manifold pressure exceeds 25 inches Hg.

4.21 BEFORE TAKEOFF

WARNING

If flight into icing conditions (visible moisture below +5°C) is anticipated or encountered during climb, cruise or descent, activate the aircraft ice protection system including the pitot heat, as described in supplement No. 10 - Ice Protection System.

Ensure that the battery and alternator switches are ON. Check that the cabin pressurization controls are properly set. Check and set all of the flight instruments as required. Check the fuel selector to make sure it is on the proper tank (fullest). Ensure auxiliary fuel pump is OFF. Check all engine gauges. The induction air should be in the PRIMARY position. Turn pitot, stall warning, windshield, and propeller heat ON if necessary.

All seat backs should be erect. Seats should be adjusted and locked in position.

The mixture and propeller control levers should be set, and the seat belts and shoulder harnesses should be fastened. Fasten the seat belts snugly around the empty seats.

Exercise and set the flaps and trim. Ensure proper flight control movement and response. The door should be properly latched and the door ajar annunciator light out. On air conditioned models, the air conditioner must be OFF to ensure normal takeoff climb performance. Release the parking brake.

4.23 TAKEOFF

NORMAL TECHNIQUE (See Chart, Section 5)

When the available runway length is well in excess of that required and obstacle clearance is no factor, the normal takeoff technique may be used. The flaps should be set in the retracted position and the pitch trim set slightly aft of neutral. Align the airplane with the runway, apply full power, and accelerate to 77 KIAS.

NOTE

Takeoffs are normally made with full throttle. However, under some off standard conditions manifold pressure and/or fuel flow indications can exceed their indicated limits at full throttle. Limit manifold pressure to 38 in. Hg maximum. (See Section 7)

Apply back pressure to the control wheel to lift off, then control pitch attitude as required to attain the desired climb speed. Retract the landing gear when a straight-ahead landing on the runway is no longer possible.

NOTE

During landing gear operation it is normal for the HYD PUMP annunciator light to illuminate until full system pressure is restored.

SHORT FIELD TECHNIQUE (See Chart, Section 5)

For short or soft field takeoff, flaps should be lowered to 20° and the pitch trim set slightly aft of neutral. Align the airplane with the runway, set the brakes, and advance the throttle to full power.

NOTE

Takeoffs are normally made with full throttle. However, under some off standard conditions manifold pressure and/or fuel flow indications can exceed their indicated limits at full throttle. Limit manifold pressure to 38 in. Hg maximum. (See Section 7)

Release the brakes, allow the airplane to accelerate to 70 KIAS depending on weight, and apply back pressure to rotate for lift off. After breaking ground, accelerate to 74 KIAS and select gear UP. Continue to climb while accelerating to the flaps up best rate-of-climb speed, 110 KIAS, if no obstacle is present, or to the flaps up best angle-of-climb speed, 90 KIAS, if obstacle clearance is a consideration. Retract the flaps while climbing out.

NOTE

During landing gear operation it is normal for the HYD PUMP annunciator light to illuminate until full system pressure is restored.

4.25 CLIMB

The best rate of climb at gross weight and maximum continuous power will be obtained at 110 KIAS. The best angle of climb may be obtained at 90 KIAS. The recommended procedure for climb is to use maximum power until all obstacles are cleared and then reduce to cruise climb power. Although there is no time limit on the use of maximum power, the use of cruise climb will result in reduced fuel burn, reduced cabin noise, increased visibility, significantly extended engine life and provide a comfortable rate of climb to cruise altitude.

TAKEOFF CLIMB

The power setting for takeoff climb, with the mixture full RICH, is 2600 RPM and full throttle. Under some off standard conditions manifold pressure and/or fuel flow indications will exceed their indicated limits at full throttle. (See Section 7) It is recommended that this power setting be used only until all obstacles are cleared.

CRUISE CLIMB

Once all obstacles are cleared, the power should be reduced to the cruise climb setting of 2500 RPM, 35 in. Hg. and mixture full RICH, with an airspeed of 125 KIAS below 22,000 ft altitude and 115 KIAS above 22,000 ft altitude.

Use of the auxiliary fuel pump should not be required in the climb due to the design of the engine driven fuel pump. However, if fuel flow fluctuations are noted at high altitude or during operations at very high ambient temperatures, the auxiliary fuel pump should be set to the LO position. Adjust the mixture to maintain the required T.I.T.

Set cabin pressurization controls during the climb in accordance with Paragraph 4.45.

4.27 CRUISING

NOTE

The cruise mixture must be set in strict accordance with the following procedure. Failure to do so will result in excess fuel burn and reduced engine life.

NOTE

Maximum continuous T.I.T. is 1750°F. Temporary operation up to 1800°F is permitted in order to define peak T.I.T. In no case should the aircraft be operated more than 30 seconds with a T.I.T. in excess of 1750°F.

The cruising speed is determined by many factors, including power setting, altitude, temperature, loading and equipment installed in the airplane.

The engine has been designed to attain the maximum possible fuel efficiency while maintaining the desired cruise power. This requires operating on the lean side of peak T.I.T. Although this procedure is different from conventional leaning procedures, it will produce the maximum fuel efficiency and will actually produce cooler engine temperatures than conventional peak T.I.T. or rich of peak operation. The cruise mixture setting is 50° lean of peak T.I.T.

After leveling off at cruise altitude, set the RPM and manifold pressure for the desired cruise power in accordance with the power setting table. Using the fuel flow indicator as a reference, lean the mixture to approximately 4 gallons per hour above the cruise fuel flow value listed in the power setting table. From this point on use the T.I.T. gage as a reference. Slowly lean to peak T.I.T. and continue leaning until the T.I.T. has fallen 50°F.

The manifold pressure may increase above cruise setting as the mixture is leaned toward peak T.I.T., when operating at or near the altitude limits of the lower power/rpm settings, or at or near 25,000 feet pressure altitude, if the ambient temperature is above standard for either condition. Should this occur, select a power setting from the power table (fig. 5-21) requiring a higher rpm or lower manifold pressure. Manifold pressure fluctuations during leaning may be prevented by reducing cruise altitude.

NOTE

The induction system must be properly maintained to obtain certified engine performance. Small leaks will significantly reduce altitude capability.

The engine power setting table defines the cruise power at the desired mixture setting of 50° lean of peak. Operation at the same manifold pressure and a richer mixture setting will produce a higher horsepower, increased engine temperatures and in the case of 75% power will exceed the approved horsepower for leaning the engine. Do not operate the aircraft in cruise with a mixture setting other than 50° lean of peak T.I.T.

For maximum service life, cylinder head temperature should be maintained below 420°F during cruise operation. If cylinder head temperatures become too high during flight, reduce them by decreasing power.

Following level-off for cruise, the pressurization system should be checked.

The pilot should monitor weather conditions while flying, and be alert for meteorological conditions which might lead to icing. Even aircraft equipped with a complete deicing option are not approved for flight in heavy icing, heavy snow, or freezing rain. (See Section 9.) Immediate steps shall be taken to exit any area where such icing conditions are inadvertently encountered. Saturated air accelerating through the induction system filter can form ice although ambient temperatures are above freezing. If induction system icing is suspected, place the induction air control in the ALTERNATE position. Alternate air should also be selected before entering clouds. Manifold pressure may decrease when alternate air is selected depending on altitude, power setting, and other factors. If ice is forming on the filter, manifold pressure could continue to deteriorate after selecting alternate air. When manifold pressure stabilizes reestablish cruise configuration. The primary filter may retain ice after leaving icing conditions, making the selection of PRIMARY induction air impractical until ice melts or sublimates.

During flight, keep account of time and fuel used in connection with power settings to determine how the fuel flow and fuel quantity gauging systems are operating.

There are no mechanical uplocks in the landing gear system. In the event of a hydraulic system malfunction, check valves should prevent the gear from extending. However, some hydraulic system malfunctions may cause the gear to free-fall to the gear down position. The true airspeed with gear down is approximately 70% of the gear retracted airspeed for any given power setting. Allowances for the reduction in airspeed and range should be made when planning extended flight between remote airfields or flight over water.

In order to keep the airplane in best lateral trim during cruise flight, the fuel should be used alternately from each tank at one hour intervals or less.

4.29 DESCENT

The recommended procedure for descent is to leave the engine controls at the cruise settings and increase the airspeed to give the desired rate of descent. Monitor the manifold pressure and adjust to maintain the cruise setting. Leave the mixture leaned to the cruise setting. This will prevent rapid engine cooling which may damage the engine. If descending with the gear retracted does not provide the desired rate of descent the gear may be extended at speeds up to 170 KIAS and the aircraft operated at speeds up to 200 KIAS with the gear extended. This procedure will significantly increase rate of descent and should provide adequate rate of descent for all normal circumstances. Should additional rate of descent be required, power can be reduced down to 20 in. Hg. while maintaining cabin pressurization. At reduced power maintain at least 1500°F T.I.T. in order to keep engine temperatures from cooling too rapidly.

Shortly after letdown is initiated, set the Cabin Altitude Controller to 1000 feet above the pressure altitude of the landing field. Adjust the rate control high enough to allow the cabin to descend to the landing setting before the aircraft descends to that altitude. For normal letdown the rate knob should be at the nine o'clock position. A higher setting should be selected for rapid descents so that the aircraft altitude does not catch up with cabin altitude.

4.31 APPROACH AND LANDING

Accomplish the Landing Checklist early in the landing approach.

The fuel selector should be on the fullest tank. Seat backs must be fully erect and seat belts and shoulder harnesses fastened and properly adjusted. The auxiliary fuel pump should be OFF. Check to ensure that the cabin is fully depressurized. The mixture and prop controls should be set. The landing gear may be lowered at speeds up to 170 KIAS and the flaps at speeds as follows:

- 10° 170 KIAS maximum
- 20° 135 KIAS maximum
- 36° 120 KIAS maximum

NOTE

During landing gear operation it is normal for the HYD PUMP annunciator light to illuminate until full system pressure is restored.

NOTE

Pump toe brakes to ensure that the system is positioned for maximum and uniform braking during landing rollout.

WARNING

After pumping several times, if one or both toe brakes are inoperative, **DO NOT** attempt landing on a short field.

The air conditioner should be OFF to ensure maximum rate of climb in the event of a go-around.

Depending on the field length and other factors the following procedures are appropriate:

NORMAL TECHNIQUE (No Performance Chart Furnished)

When available runway length is in excess of required runway length, a normal approach and landing technique may be utilized. The aircraft should be flown down the final approach course at 85 KIAS with power required to maintain the desired approach angle. The amount of flap used during approach and landing and the speed of the aircraft at contact with the runway should be varied according to the landing surface, conditions of wind and aircraft loading. It is generally good practice to contact the ground at the minimum possible safe speed consistent with existing conditions. As landing distances with this technique will vary, performance charts are not furnished.

SHORT FIELD LANDING APPROACH POWER OFF (See Chart, Section 5)

When available runway length is minimal or obstacle clearance to landing is of major concern, this approach/landing technique may be employed. The aircraft should be flown on the final approach at 77 KIAS with full flaps, gear down and idle power. The glide path should be stabilized as early as possible. Reduce the speed slightly during landing flareout and contact the ground close to stall speed. After ground contact, retract the flaps and apply full aft travel on the control wheel and maximum braking consistent with existing conditions.

4.33 GO-AROUND

To initiate a go-around from a landing approach, the mixture should be set to full RICH, the prop control should be at full INCREASE, and the throttle should be advanced to full power while the pitch attitude is increased to obtain the balked landing climb speed of 80 KIAS. Retract the landing gear and slowly retract the flaps when a positive climb is established. Allow the airplane to accelerate to the best angle of climb speed (90 KIAS) for obstacle clearance or to the best rate of climb speed (110 KIAS) if obstacles are not a factor. Reset the longitudinal trim as required.

4.35 STOPPING ENGINE

Prior to shutdown the flaps should be raised and all radio and electrical equipment should be turned OFF.

The air conditioner should be turned OFF, the prop control set in the full INCREASE position, and the engine stopped by pulling the mixture control back to idle cut-off. The throttle should be CLOSED to avoid engine vibration while stopping. Then the magneto, alternator, and battery switches must be turned OFF.

4.37 PARKING

If necessary, the airplane should be moved on the ground with the aid of the nose wheel tow bar provided with each airplane and secured in the forward baggage area. The aileron and elevator controls should be secured by looping the safety belt through the control wheel and pulling it snug. The flaps should be fully retracted.

Tie downs can be secured to the main gear and to the tail skid. The rudder is held in position by its connections to the nose wheel steering and normally does not have to be secured.

4.39 STALLS

The stall characteristics of the Malibu are conventional. An approaching stall is indicated by a stall warning horn which is activated between five and ten knots above stall speed. Mild airframe buffeting and pitching may also precede the stall.

The gross weight stalling speed with power off and full flaps is 58 KIAS. With the flaps up this speed is increased to 69 KIAS. Loss of altitude during

stalls can be as great as 550 feet, depending on configuration and power.

NOTE

The stall warning system is inoperative with the battery and alternator switches OFF.

During preflight, the stall warning system should be checked by turning the battery switch on and raising the lift detector to determine if the horn is actuated.

4.41 TURBULENT AIR OPERATION

In keeping with good operating practice used in all aircraft, it is recommended that when turbulent air is encountered or expected, the airspeed be reduced to maneuvering speed to reduce the structural loads caused by gusts and to allow for inadvertent speed build-ups which may occur as a result of the turbulence or of distractions caused by the conditions. (Refer to paragraph 2.3 for maneuvering speeds.)

4.43 LANDING GEAR

The pilot should become familiar with the function and significance of the landing gear position indicators and warning lights.

The red GEAR WARNING annunciator and gear warning horn will operate simultaneously under the following conditions:

- (a) In flight when the throttle is reduced to the point at which manifold pressure is approximately 14 inches of mercury or below and the landing gear selector is not in the DOWN position.
- (b) In flight when the flaps are extended more than 10° and the landing gear selector is in the UP position.
- (c) On the ground when the landing gear selector is in the UP position. The landing gear squat switch activates to prevent operation of the retract side of the hydraulic pump on the ground.

The three green lights on the instrument panel operate individually as each associated gear is locked in the extended position.

NOTE

Day/night dimmer switch must be in the DAY position to obtain full intensity of the gear position indicator lights during daytime flying. When aircraft is operated at night the switch should be in the NIGHT position to dim the gear lights.

4.45 CABIN PRESSURIZATION SYSTEM

Cabin pressurization system controls, gauges and switches are located in the lower left instrument panel. (Refer to Section 7, Figure 7-21.)

The cabin pressurization system controls, gauges and switches are as follows:

- (a) Cabin Altitude Controller with Rate of Change Control
- (b) Cabin Pressure Altitude/Differential Pressure/Rate of Climb Gauge
- (c) Cabin Dump Switch
- (d) Cabin Pressurization Control

Prior to starting engines, check the operation of the cabin pressurization control. Note that a firm effort is required to move the lever out of either the outside air or the pressurized air position. If little effort is required to move the lever, be suspicious of a broken control cable. If a cable is broken, the air control valve may have failed in either the open or closed position. If failed open, pressurized flight will not be possible, but unpressurized flight will be possible. If failed closed, pressurized flight would be possible but should not be attempted, as it would not be possible to bring in fresh air should contamination occur.

Set cabin altitude on the cabin altitude controller to 1000 feet above the field pressure altitude before takeoff. (Cabin pressurization will begin as the cabin passes through the altitude selected.) Cabin altitude will remain at the selected altitude until maximum cabin differential (5.5 PSI) is reached, at which time the cabin altitude will begin to climb until at 25000 feet aircraft pressure altitude the cabin pressure altitude will be approximately 8000 feet.

For flight below an airplane altitude of 12500 feet, the cabin altitude control should be left at the takeoff setting. For flight above 12500 feet, at which point maximum differential will be achieved, set the cabin altitude on the cabin altitude controller to 1000 feet above field elevation for takeoff. Once the cabin has begun to pressurize and the controller has captured isobaric control, reset the aircraft altitude on the cabin altitude controller to 1000 feet above the cruise altitude and adjust the cabin rate of climb as desired. The normal 9 o'clock position should provide a cabin rate of climb of approximately 500 feet per minute. No additional adjustment should be required prior to descent unless cruise altitude is changed, at which point the aircraft altitude should be reset to 1000 feet above the new cruise altitude.

To descend for landing be certain that the selected cabin altitude is higher than the pressure altitude of the landing field. Shortly after letdown is initiated, set the cabin altitude to 1000 feet above the pressure altitude of the landing field and adjust the rate control high enough to allow the cabin to descend to the landing setting before the aircraft descends to that altitude. For normal letdown the rate knob should be at the normal 9 o'clock position. A higher setting should be selected for rapid descents so that the aircraft altitude does not catch up with the cabin altitude.

WARNING

Do not land with aircraft pressurized.

To repressurize while in flight push the pressurization control in and turn the dump switch OFF.

4.47 WEIGHT AND BALANCE

It is the responsibility of the owner and pilot to determine that the airplane remains within the allowable weight vs. center of gravity envelope while in flight.

For weight and balance data, refer to Section 6 (Weight and Balance).

4.49 ICING INFORMATION

"THE FOLLOWING WEATHER CONDITIONS MAY BE CONDUCTIVE TO SEVERE IN-FLIGHT ICING"

Visible rain at temperatures below 0 degrees Celsius ambient air temperature.

Droplets that splash or splatter on impact at temperature below 0 degrees Celsius ambient air temperature.

"PROCEDURES FOR EXITING THE SEVERE ICING ENVIRONMENT"

These procedures are applicable to all flight phases from takeoff to landing. Monitor the ambient air temperature. While severe icing may form at temperatures as cold as -18 degrees Celsius, increased vigilance is warranted at temperatures around freezing with visible moisture present. If the visual cues specified in the Limitations Section of the AFM for identifying severe icing conditions are observed, accomplish the following:

Immediately request priority handling from Air Traffic Control to facilitate a route or an altitude change to exit the severe icing conditions in order to avoid extended exposure to flight conditions more severe than those for which the airplane has been certificated.

Avoid abrupt and excessive maneuvering that may exacerbate control difficulties.

Do not engage the autopilot.

If the autopilot is engaged, hold the control wheel firmly and disengage the autopilot.

If an unusual roll response or uncommanded roll control movement is observed, reduce the angle-of-attack.

Do not extend flaps when holding in icing conditions. Operation with flaps extended can result in a reduced wing angle-of-attack, with the possibility of ice forming on the upper surface further aft on the wing than normal, possibly aft of the protected area.

If the flaps are extended, do not retract them until the airframe is clear of ice.

Report these weather conditions to Air Traffic Control.

THIS PAGE INTENTIONALLY LEFT BLANK

**FOR REFERENCE ONLY
NOT FOR FLIGHT**

**TABLE OF CONTENTS
SECTION 5
PERFORMANCE**

Paragraph No.		Page No.
5.1	General	5-1
5.3	Introduction - Performance and Flight Planning.....	5-1
5.5	Flight Planning Example	5-3
5.7	Performance Graphs	5-9
	List of Figures.....	5-9

FOR REFERENCE ONLY
NOT FOR FLIGHT

THIS PAGE INTENTIONALLY LEFT BLANK

FOR REFERENCE ONLY
NOT FOR FLIGHT

**SECTION 5
PERFORMANCE**

5.1 GENERAL

All of the required (FAA regulations) and complementary performance information is provided by this section.

Performance information associated with those optional systems and equipment which require handbook supplements is provided by Section 9 (Supplements).

5.3 INTRODUCTION - PERFORMANCE AND FLIGHT PLANNING

The performance information presented in this section is based on measured Flight Test Data corrected to I.C.A.O. standard day conditions and analytically expanded for the various parameters of weight, altitude, temperature, etc.

The performance charts are unfactored and do not make any allowance for varying degrees of pilot proficiency or mechanical deterioration of the aircraft. This performance, however, can be duplicated by following the stated procedures in a properly maintained airplane.

Effects of conditions not considered on the charts must be evaluated by the pilot, such as the effect of soft or grass runway surface on takeoff and landing performance, or the effect of winds aloft on cruise and range performance. Endurance can be grossly affected by improper leaning procedures, and inflight fuel flow quantity checks are recommended.

REMEMBER! To get chart performance, follow the chart procedures.

The information provided by paragraph 5.5 (Flight Planning Example) outlines a detailed flight plan using performance charts in this section. Each chart includes its own example to show how it is used.

WARNING

Performance information derived by extrapolation beyond the limits shown on the charts should not be used for flight planning purposes.

**FOR REFERENCE ONLY
NOT FOR FLIGHT**

5.5 FLIGHT PLANNING EXAMPLE

(a) Aircraft Loading

The first step in planning the flight is to calculate the airplane weight and center of gravity by utilizing the information provided by Section 6 (Weight and Balance) of this handbook.

The basic empty weight for the airplane as licensed at the factory has been entered in Figure 6-5. If any alterations to the airplane have been made affecting weight and balance, reference to the aircraft logbook and Weight and Balance Record (Figure 6-7) should be made to determine the current basic empty weight of the airplane.

Make use of the Weight and Balance Loading Form (Figure 6-11) and the C.G. Range and Weight graph (Figure 6-15) to determine the total weight of the airplane and the center of gravity position.

After proper utilization of the information provided, the following weights have been determined for consideration in the flight planning example.

The landing weight cannot be determined until the weight of the fuel to be used has been established (refer to item (g) (1).

(1) Basic Empty Weight	2625 lbs.
(2) Occupants (4 x 170 lbs.)	680 lbs.
(3) Baggage and Cargo	100 lbs.
(4) Fuel (6 lb./gal. x 60)	360 lbs.
(5) Takeoff Weight	3765 lbs.
(6) Landing Weight	
(a)(5) minus (g)(1),	
(3765 lbs. minus 230 lbs.)	3535 lbs.

The takeoff weight is below the maximum of 4100 lbs. and the weight and balance calculations have determined the C.G. position within the approved limits.

(b) Takeoff and Landing

Now that the aircraft loading has been determined, all aspects of the takeoff and landing must be considered.

All of the existing conditions at the departure and destination airport must be acquired, evaluated and maintained throughout the flight.

Apply the departure airport conditions and takeoff weight to the appropriate Takeoff Ground Roll and Takeoff Distance (Figures 5-9, 5-11, 5-13 and 5-15) to determine the length of runway necessary for the takeoff and/or the obstacle clearance.

The landing distance calculations are performed in the same manner using the existing conditions at the destination airport and, when established, the landing weight.

The conditions and calculations for the example flight are listed below. The takeoff and landing distances required for the flight have fallen well below the available runway lengths.

	Departure Airport	Destination Airport
(1) Pressure Altitude	500 ft.	2000 ft.
(2) Temperature	15°C	12°C
(3) Wind Component (Headwind)	10 KTS	0 KTS
(4) Runway Length Available	3400 ft.	5000 ft.
(5) Takeoff and Landing Distance Required	1750 ft.*	1770 ft.**

*reference Figures 5-9, 5-11, 5-13, 5-15

**reference Figures 5-33, 5-35

NOTE

The remainder of the performance charts used in this flight plan example assume a no wind condition. The effect of winds aloft must be considered by the pilot when computing climb, cruise and descent performance.

(c) Climb

The next step in the flight plan is to determine the necessary climb segment components.

The desired cruise pressure altitude and corresponding cruise outside air temperature values are the first variables to be considered in determining the climb components from the Time, Distance, and Fuel to Climb graph (Figure 5-19). After the fuel, distance and time for the cruise pressure altitude and outside air temperature values have been established, apply the existing conditions at the departure field to graph (Figure 5-19). Now, subtract the values obtained from the graph for the field of departure conditions from those for the cruise pressure altitude.

The remaining values are the true fuel, distance and time components for the climb segment of the flight plan corrected for field pressure altitude and temperature.

The following values were determined from the above instructions in the flight planning example.

- | | |
|---|--------------------|
| (1) Cruise Pressure Altitude | 20000 ft. |
| (2) Cruise OAT | -15° C |
| (3) Time to Climb
(19 min. minus 1 min.) | 18 min.* |
| (4) Distance to Climb (39
nautical miles minus
1 nautical mile) | 38 nautical miles* |
| (5) Fuel to Climb (11 gal
minus 1 gal.) | 10 gal.* |

*reference Figure 5-19

(d) Descent

The descent data will be determined prior to the cruise data to provide the descent distance for establishing the total cruise distance.

Utilizing the cruise pressure altitude and OAT, determine the basic time, distance and fuel for descent (Figure 5-27). These figures must be adjusted for the field pressure altitude and temperature at the destination airport. To find the necessary adjustment values, use the existing pressure altitude and temperature conditions at the destination airport as variables to find the fuel, distance and time values from the graph (Figure 5-27). Now, subtract the values obtained from the field conditions from the values obtained from the cruise conditions to find the true fuel, distance and time values needed for the descent segment of the flight plan.

The values obtained by proper utilization of the graphs for the descent segment of the example are shown below.

- | | |
|--|--------------------|
| (1) Time to Descend
(18 min. minus 3 min.) | 15 min* |
| (2) Distance to Descend
(60 nautical miles minus
7 nautical miles) | 53 nautical miles* |
| (3) Fuel to Descend
(3.5 gal. minus 1.0 gal.) | 2.5 gal* |

(e) Cruise

Using the total distance to be traveled during the flight, subtract the previously calculated distance to climb and distance to descend to establish the total cruise distance. Refer to the appropriate Teledyne Continental Operator's Manual and the Power Setting Table (refer to page 5-22) when selecting the cruise power setting. The established pressure altitude and temperature values and the selected cruise power should not be utilized to determine the true airspeed from the Cruise Speed Vs. Altitude (Figure 5-21).

*reference Figure 5-27

Calculate the cruise fuel consumption for the cruise power setting from the information provided by the Teledyne Continental Operator's Manual and the Power Setting Table (refer to page 5-22).

The cruise time is found by dividing the cruise distance by the cruise speed and the cruise fuel is found by multiplying the cruise fuel consumption by the cruise time.

The cruise calculations established for the cruise segment of the flight planning example are as follows:

- | | |
|------------------------------|--------------------|
| (1) Total Distance | 400 nautical miles |
| (2) Cruise Distance | |
| (e)(1) minus (c)(4) minus | |
| (d)(2), (400 nautical | |
| miles minus 38 nautical | |
| miles minus 53 nautical | |
| miles) | 309 nautical miles |
| (3) Cruise Power | |
| (50° lean of peak T.I.T.) | 75% rated power |
| (4) Cruise Speed | 206 KTS TAS* |
| (5) Cruise Fuel Consumption | 15.5 GPH* |
| (6) Cruise Time | |
| (e)(2) divided by (e)(4), | |
| 309 nautical miles divided | |
| by 206 KTS | 1.5 hrs. (90 min.) |
| (7) Cruise Fuel | |
| (e)(5) multiplied by (e)(6), | |
| (15.5 GPH multiplied | |
| by 1.5 hrs.) | 23.2 gal. |
| (f) Total Flight Time | |

The total flight time is determined by adding the time to climb, the time to descend and the cruise time. Remember! The time values taken from the climb and descent graphs are in minutes and must be converted to hours before adding them to the cruise time.

*reference Figure 5-21 and Page 5-22

The following flight time is required for the flight planning example:

- (1) Total Flight Time
(c)(3) plus (d)(1) plus (e)(6),
(.30 hrs. plus .25 hrs. plus 1.50 hrs.) 2.05 hrs.
(18 min. plus 15 min. plus 90 min.) 123 min.

(g) Total Fuel Required

Determine the total fuel required by adding the fuel for start, taxi, and takeoff (2.7 gal., calculated by allowing 5 minutes of fuel flow at takeoff power), the fuel to climb, the fuel to descend, and the cruise fuel. When the total fuel (in gallons) is determined, multiply this value by 6 lb/gal to determine the total fuel weight used for the flight.

The total fuel calculations for the example flight plan are shown below.

- (1) Total Fuel Required
Fuel for Start, Taxi and Takeoff plus
(c)(5) plus (d)(3) plus (e)(7), (2.7 gal.
plus 10 gal. plus 2.5 gal. plus 23.2 gal.) 38.4 gal.
(38.4 gal. multiplied by 6 lb/gal.) 230 lbs.

FOR REFERENCE ONLY
NOT FOR FLIGHT

5.7 PERFORMANCE GRAPHS

LIST OF FIGURES

Figure No.		Page No.
5-1	Airspeed Calibration	5-11
5-3	Angle of Bank Vs. Stall Speed.....	5-12
5-5	Temperature Conversion.....	5-13
5-7	Wind Components	5-14
5-9	Takeoff Ground Roll, 0° Flaps	5-15
5-11	Takeoff Ground Roll, 20° Flaps	5-16
5-13	Takeoff Distance Over 50 Ft. Obstacle, 0° Flaps	5-17
5-15	Takeoff Distance Over 50 Ft. Obstacle, 20° Flaps	5-18
5-17	Rate of Climb	5-19
5-19	Maximum Continuous Power Time,	5-20
	Distance and Fuel to Climb	
5-20	Cruise Climb Time, Distance and	5-21
	Fuel to Climb	
5-21	Cruise Speed Vs. Altitude	5-23
5-23	Range.....	5-24
5-25	Endurance	5-25
5-27	Time, Distance and Fuel to Descend.....	5-26
5-29	Glide Time and Distance	5-27
5-31	Balked Landing Climb	5-28
5-33	Landing Distance Over 50 Ft. Obstacle	5-29
5-35	Landing Ground Roll	5-30

THIS PAGE INTENTIONALLY LEFT BLANK

FOR REFERENCE ONLY
NOT FOR FLIGHT

AIRSPEED CALIBRATION

Example:

Gear up, Flaps 0°:
Air speed: 140 KIAS / 138 KCAS
Gear down, Flaps down:
Air speed: 110 KIAS / 105 KCAS

ASSOCIATED CONDITIONS:
WEIGHT 4100 LBS.
WITH OR WITHOUT DE-ICE BOOTS
ZERO INSTRUMENT ERROR

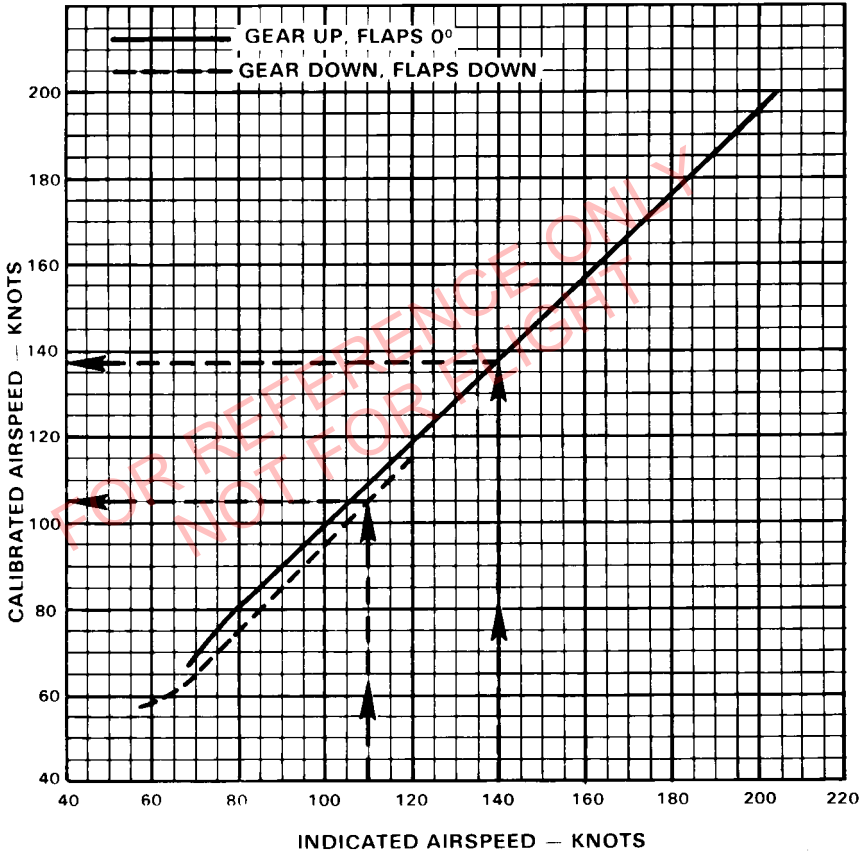

AIRSPEED CALIBRATION

Figure 5-1

ANGLE OF BANK VS. STALL SPEED

ASSOCIATED CONDITIONS:
WEIGHT 4100 LBS.
WITH OR WITHOUT DE-ICE BOOTS
ZERO INSTRUMENT ERROR

Example:

Gear up, Flaps 0°:

Stall speed: 82 KIAS at 45° angle of bank

Gear down, Flaps down:

Stall speed: 75 KIAS at 45° angle of bank

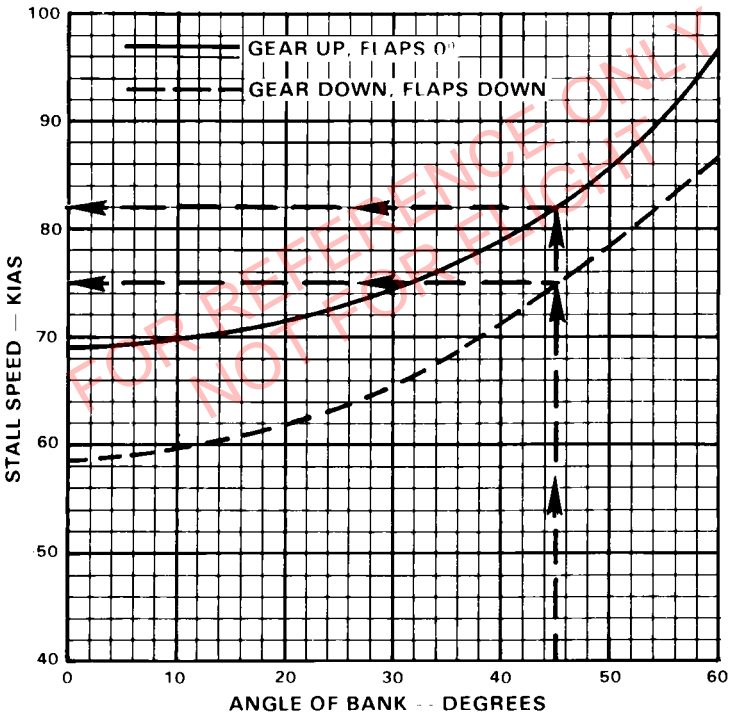

ANGLE OF BANK VS. STALL SPEED

Figure 5-3

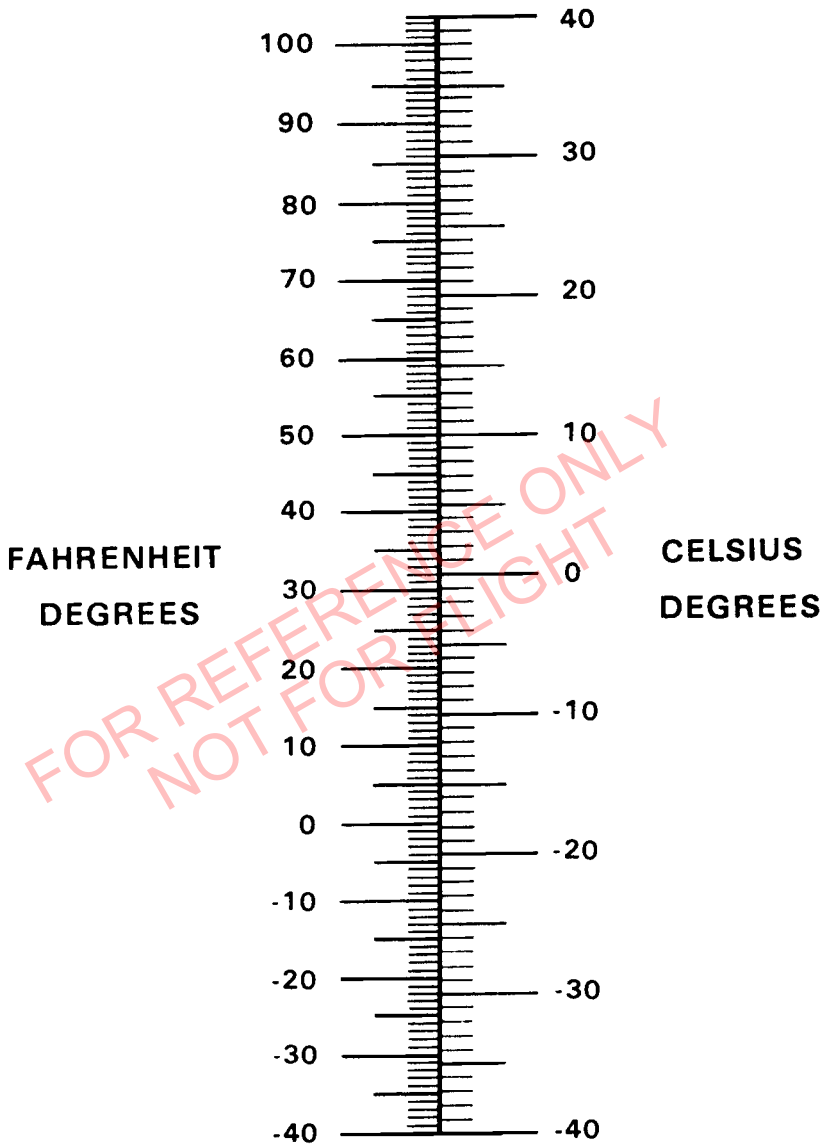

TEMPERATURE CONVERSION

Figure 5-5

WIND COMPONENTS

Example:

Wind velocity: 30 knots

Angle between flight path and wind: 30°

Headwind component: 26 knots

Crosswind components: 15 knots

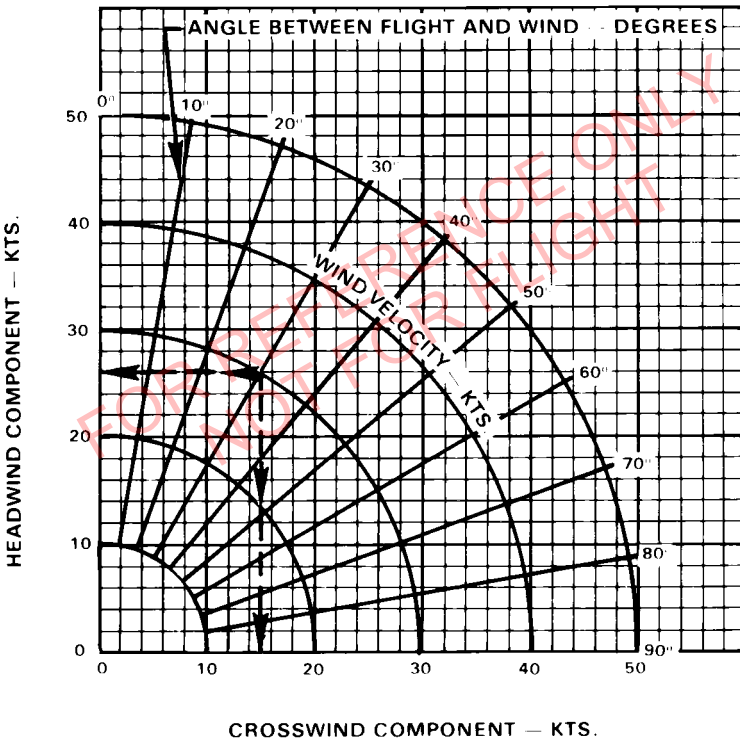

WIND COMPONENTS

Figure 5-7

TAKEOFF GROUND ROLL 0° FLAPS

Example:

Pressure altitude: 500 Ft.

Outside air temperature: 15°C

Weight: 3765 Pounds

Wind: 10 Kts. Headwind

Takeoff ground roll: 1490 Ft.

ASSOCIATED CONDITIONS:

FLAPS 0°, 2600 RPM & FULL THROTTLE BEFORE

BRAKE RELEASE, LIFTOFF SPEED 77 KIAS

PAVED LEVEL DRY RUNWAY

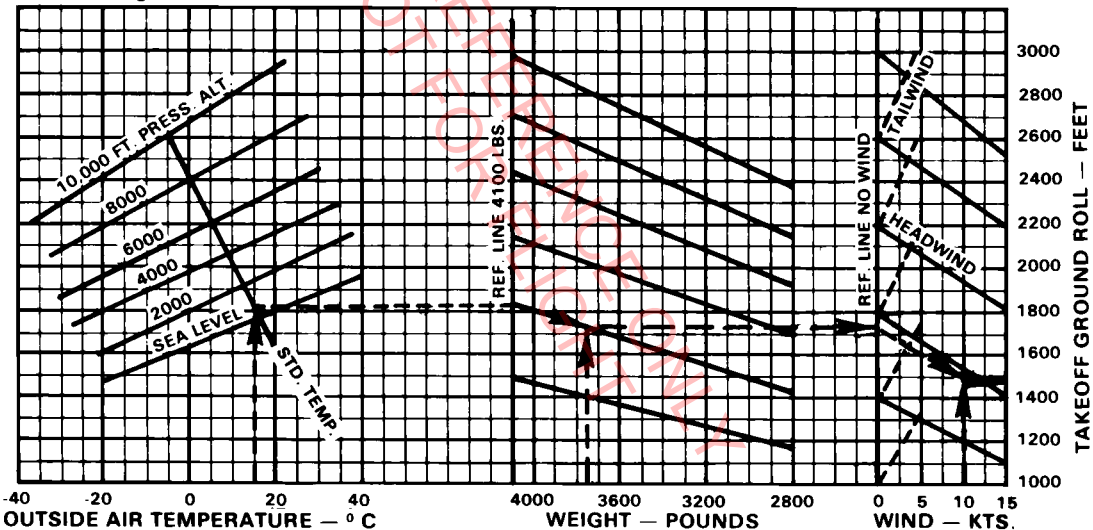

TAKEOFF GROUND ROLL, 0° FLAPS

Figure 5-9

TAKEOFF GROUND ROLL 20° FLAPS

Example:

Pressure altitude: 500 Ft.

Outside air temperature: 15° C

Weight: 3765 Pounds

Wind: 10 Kts. Headwind

Takeoff ground roll: 1170 Ft.

ASSOCIATED CONDITIONS:

FLAPS 20°, 2600 RPM & FULL THROTTLE BEFORE

BRAKE RELEASE, LIFTOFF SPEED 70 KIAS

PAVED LEVEL DRY RUNWAY

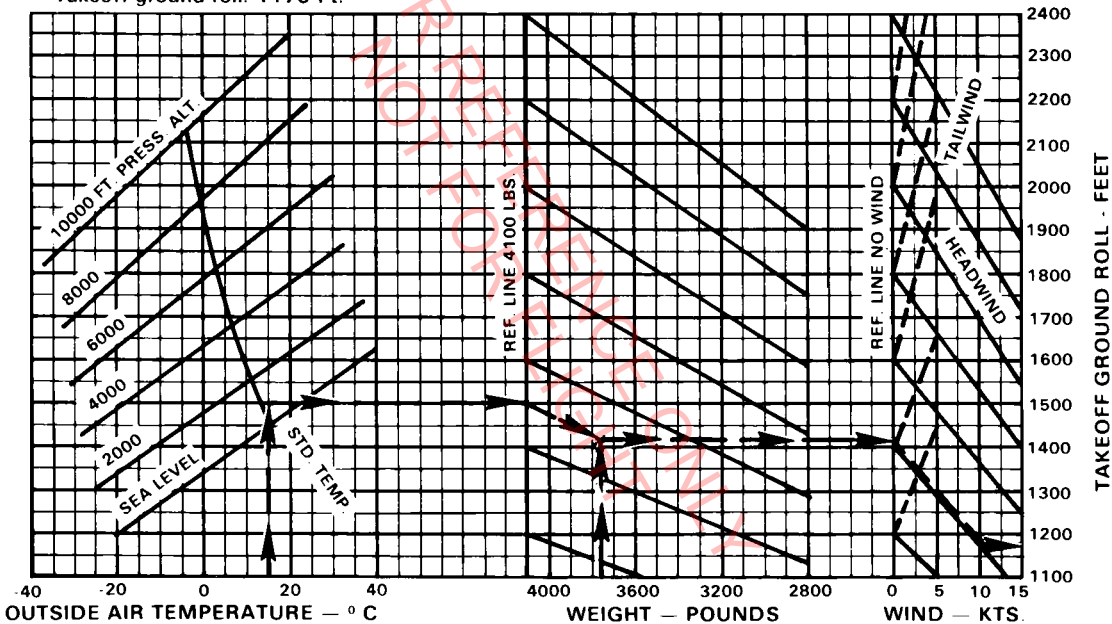

TAKEOFF GROUND ROLL, 20° FLAPS

Figure 5-11

TAKEOFF DISTANCE OVER 50 FT. OBSTACLE 0° FLAPS

Example:

Pressure altitude: 500 Ft.
Outside air temperature: 15° C
Weight: 3765 Pounds
Wind: 10 Kts. Headwind
Takeoff distance: 2350 Ft.

ASSOCIATED CONDITIONS:

FLAPS 0°, 2600 RPM & FULL THROTTLE BEFORE
BRAKE RELEASE, LIFTOFF SPEED 77 KIAS &
OBSTACLE CLEARANCE SPEED 89 KIAS
PAVED LEVEL DRY RUNWAY

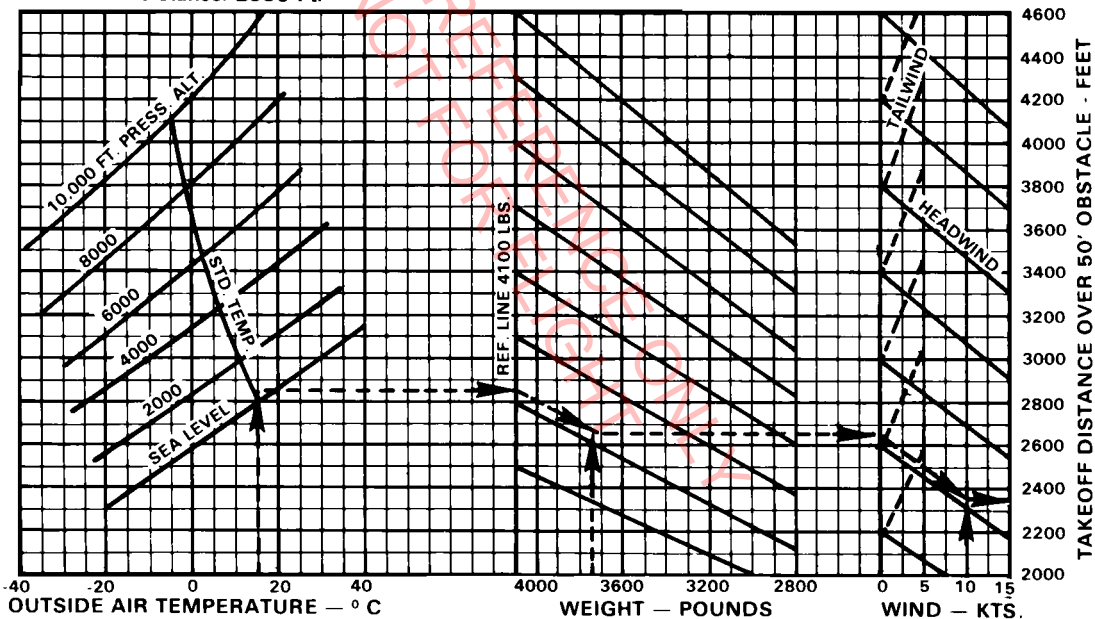

TAKEOFF DISTANCE OVER 50 FT. OBSTACLE, 0° FLAPS

Figure 5-13

PA-46-310P

TAKEOFF DISTANCE OVER 50 FT. OBSTACLE 20° FLAPS

Example:

Pressure altitude: 500 Ft.

Outside air temperature: 15° C

Weight: 3765 Pounds

Wind: 10 Kts. Headwind

Takeoff distance: 1750 Ft.

ASSOCIATED CONDITIONS:

FLAPS 20°, 2600 RPM & FULL THROTTLE BEFORE

BRAKE RELEASE, LIFTOFF SPEED 70 KIAS &

OBSTACLE CLEARANCE SPEED 74 KIAS

PAVED LEVEL DRY RUNWAY

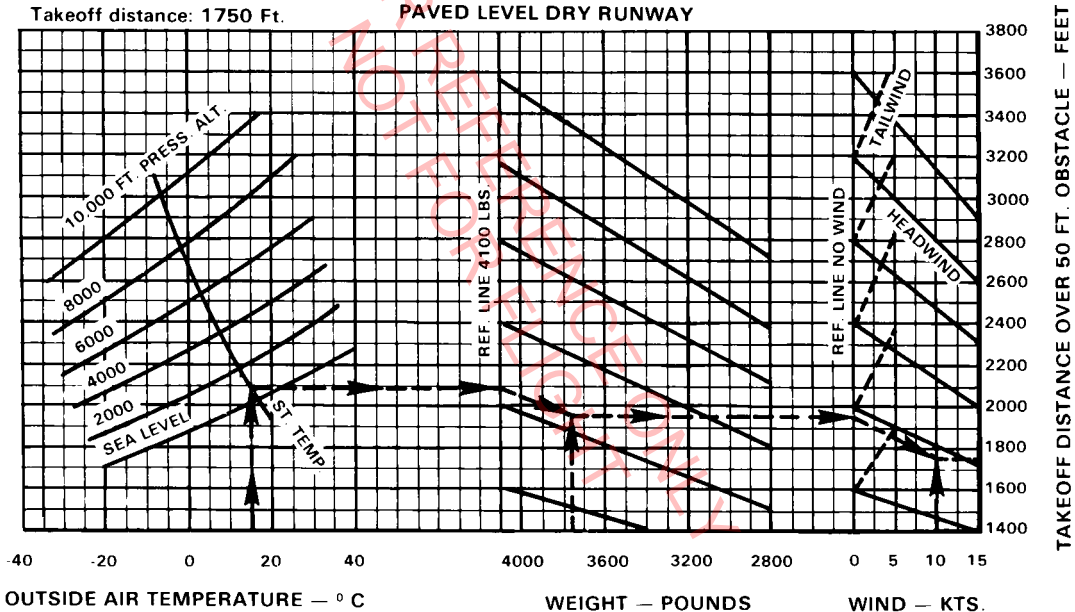

TAKEOFF DISTANCE OVER 50 FT. OBSTACLE, 20° FLAPS

Figure 5-15

RATE OF CLIMB

Example:

Pressure altitude: 4000 ft.
Outside air temperature: 25° C
Weight: 3500 lbs.
Rate of climb: 1335 FPM

ASSOCIATED CONDITIONS:
GEAR UP, FLAPS 0°
2600 RPM & FULL THROTTLE
CLIMB SPEED, 110 KIAS

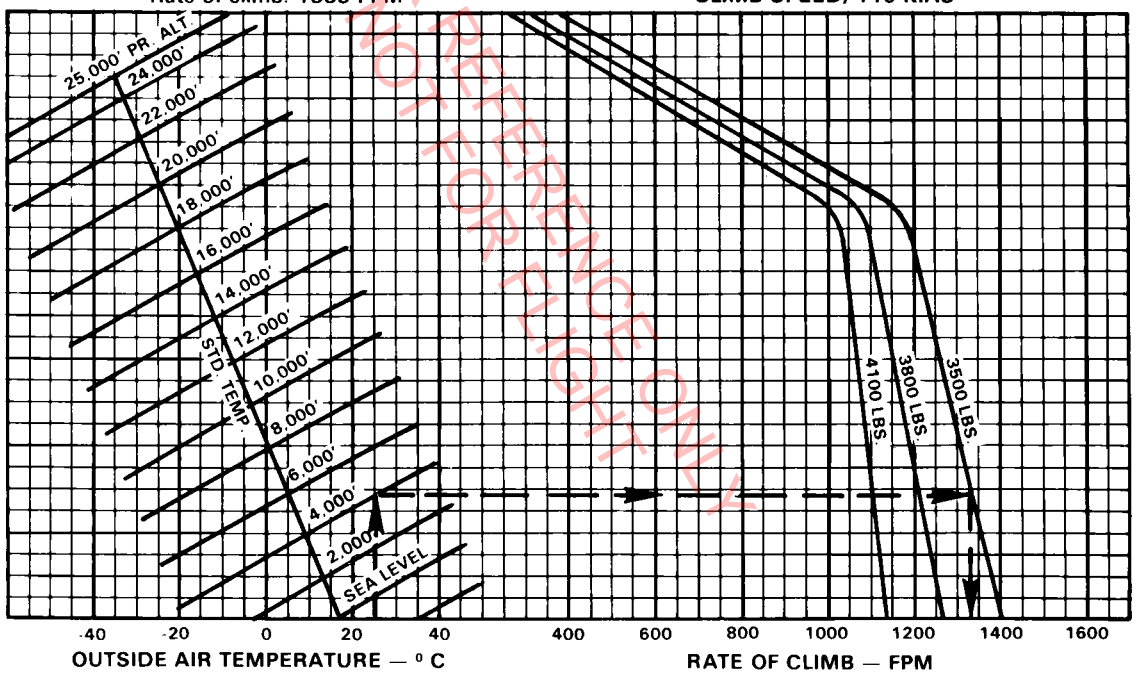

RATE OF CLIMB

Figure 5-17

MAXIMUM CONTINUOUS POWER TIME DISTANCE AND FUEL TO CLIMB

Example:

Departure: 500 Ft. Press. Alt. OAT: 15° C
 Cruise: 20000 Ft. Press. Alt. OAT: -15° C
 Fuel to climb: 11-1 10 gal.
 Time to climb: 19-1 18 min.
 Distance to climb: 39-1 38 naut. miles

ASSOCIATED CONDITIONS:
 GEAR UP, FLAPS 0°
 2600 RPM, FULL THROTTLE
 WEIGHT 4100 LBS.
 CLIMB SPEED 110 KIAS

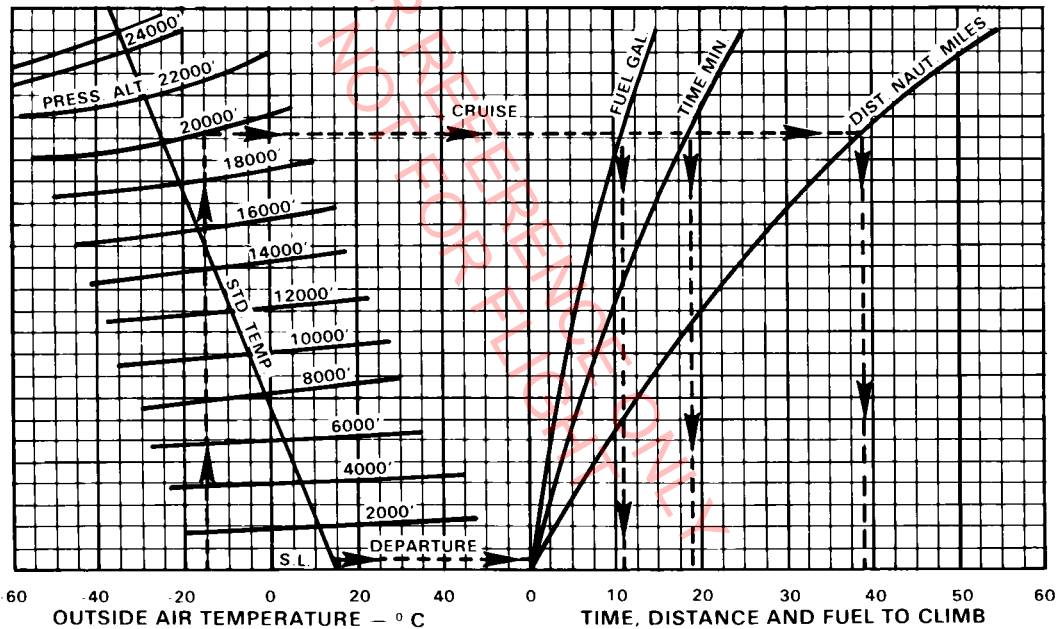

TIME, DISTANCE AND FUEL TO CLIMB

Figure 5-19

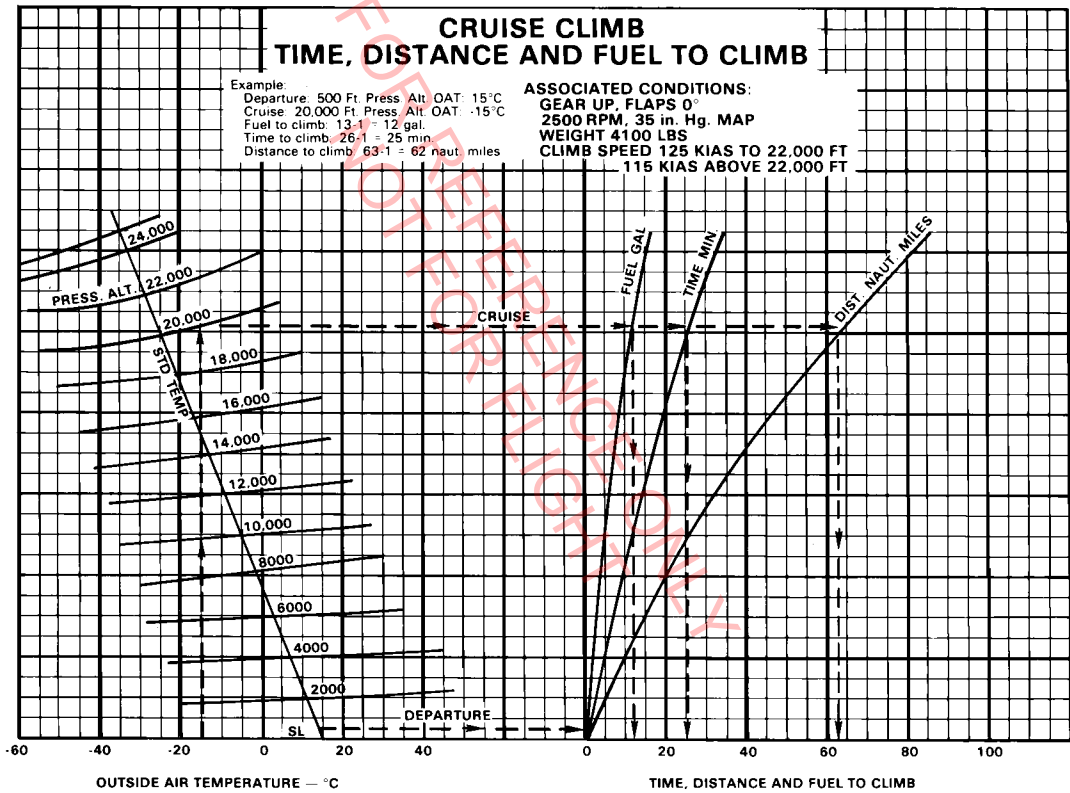

CRUISE CLIMB
TIME, DISTANCE AND FUEL TO CLIMB
Figure 5-20

POWER SETTING TABLE
REFERENCE FIG. 5-21

ASSOCIATED CONDITIONS

	RPM	Man. Press.	Approx. Fuel Flow	TIT
High Speed Cruise (75%)	2400	31" Hg.	16 GPH	50° Lean of Peak
	2500	29.5" Hg.		
Economy Cruise (65%)	2300	28" Hg.	14 GPH	50° Lean of Peak
	2400	26.5" Hg.		
	2500	25" Hg.		
Long Range Cruise (55%)	2200	25" Hg.	12 GPH	50° Lean of Peak
	2300	24" Hg.		
	2400	23" Hg.		
Holding	2200	21" Hg.	10 GPH	50° Lean of Peak

The higher rpm settings should be used at altitudes above 20,000 ft. (see Section 4.27). Holding power is not attainable or intended for use at high altitude.

Cruise fuel flow increases one GPH for each 20° C below standard temperature and decreases one GPH for each 20° C above standard temperature.

The cruise speeds shown are at mid-cruise weight, 3740 pounds. The speed differential for weight is 0.8 knots per 100 pounds, faster at lesser weights and slower at heavier weights.

The leaning procedure to establish 50° lean of peak T.I.T. is discussed in Section 4.

*Example:

Cruise altitude: 20, ft.

Cruise power: High speed cruise (75%)

Cruise O.A.T.: -15° C (10° C above std.)

Cruise weight: 3650 lbs. (90 lbs. below mid-cruise weight)

Cruise fuel flow: 15.5 gph (16.0 - 0.5 gph for non std. temp.)

Cruise speed: 206 KTAS (205 + 1 KTAS for weight below mid-cruise)

*reference Figure 5-21

CRUISE SPEED VS. ALTITUDE

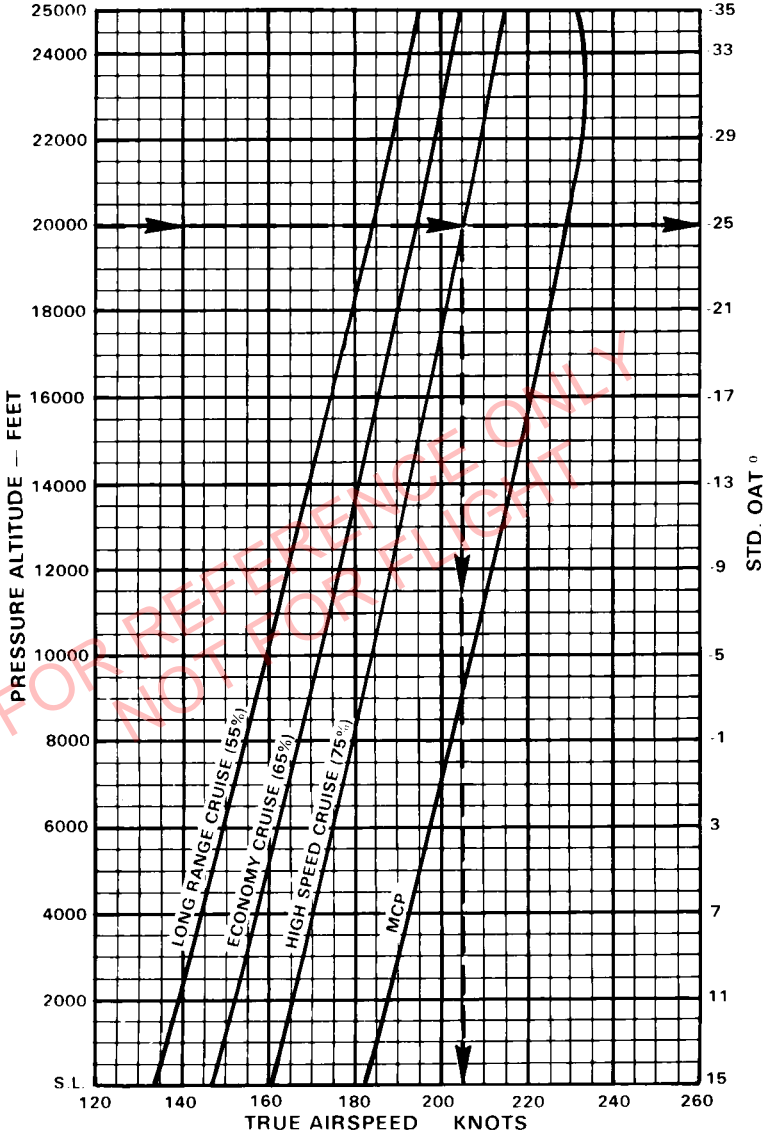

CRUISE SPEED VS. ALTITUDE

Figure 5-21

RANGE

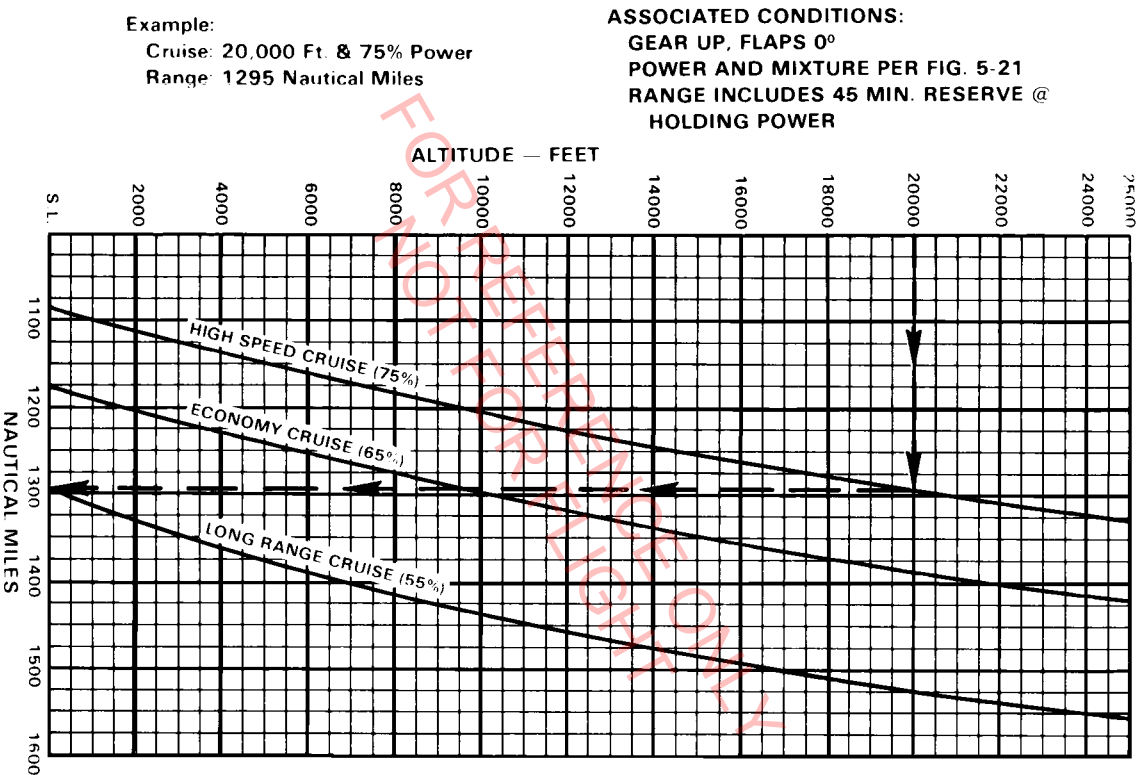

ASSOCIATED CONDITIONS:
GEAR UP, FLAPS 0°
POWER AND MIXTURE PER FIG. 5-21
RANGE INCLUDES 45 MIN. RESERVE @
HOLDING POWER

Example:
Cruise: 20,000 Ft. & 75% Power
Range: 1295 Nautical Miles

RANGE

Figure 5-23

ENDURANCE

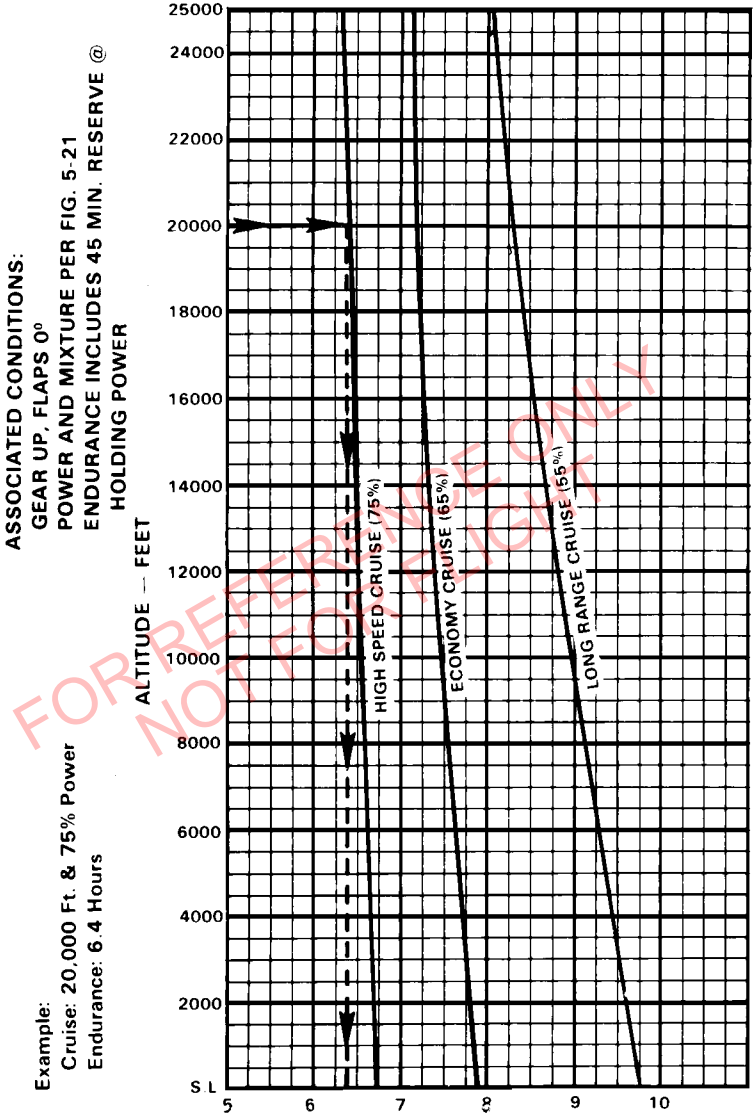

ENDURANCE

Figure 5-25

TIME DISTANCE AND FUEL TO DESCEND

Example:

Cruise: 20,000 Ft. Press. Alt. OAT: -15° C
 Destination: 2000 Ft. Press. Alt. OAT: 12° C
 Fuel to descend 3.5-1 2.5 Gal.
 Time to descend 18-3 15 Min.
 Dist. to descend 60-7 53 Naut. Miles

ASSOCIATED CONDITIONS:
 GEAR UP, FLAPS 0°
 2200 RPM, 25" HG. MAP
 DESCENT SPEED 173 KIAS

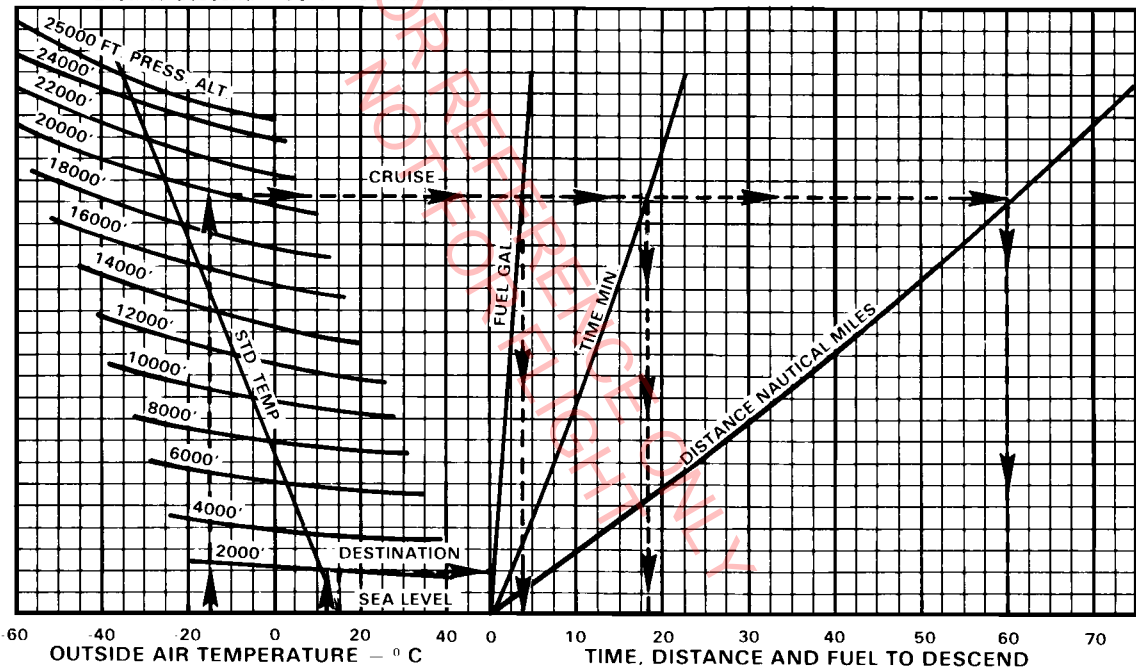

TIME, DISTANCE AND FUEL TO DESCEND

Figure 5-27

GLIDE TIME AND DISTANCE

Example:

Cruise: 20,000 Ft. OAT: -15° C
Glide time: 27 Min.
Glide distance: 46 Nautical Miles

ASSOCIATED CONDITIONS:

GEAR UP, FLAPS 0°, POWER OFF
PROPELLER CONTROL FULL DECREASE
GLIDE SPEED 90 KIAS

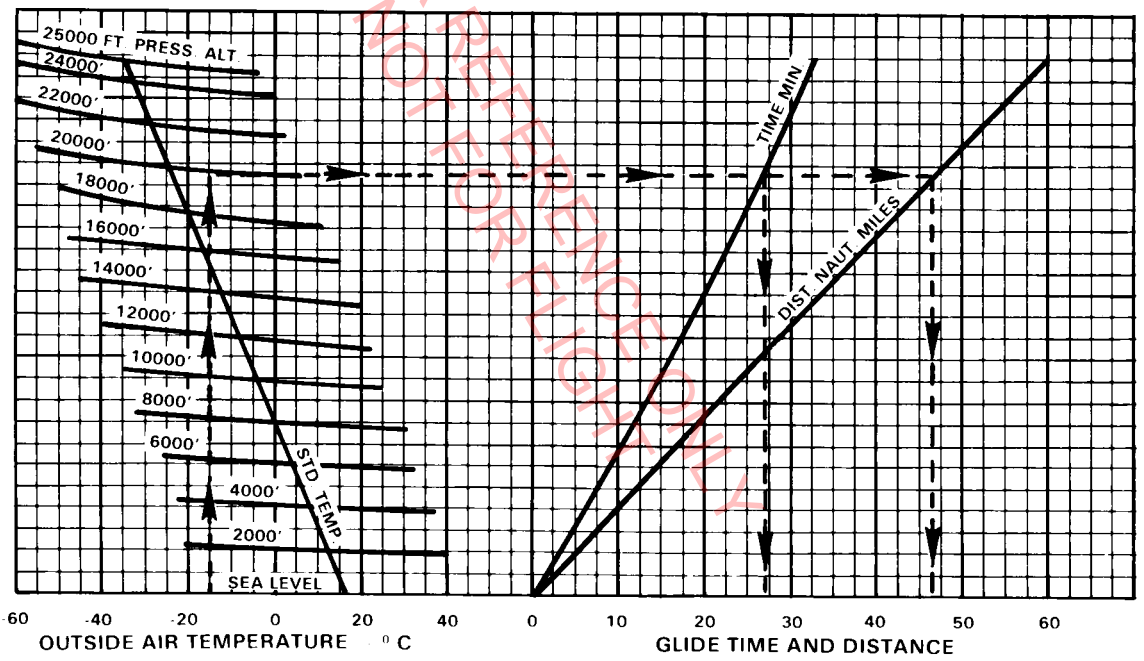

GLIDE TIME AND DISTANCE

Figure 5-29

BALKED LANDING CLIMB

Example:

Pressure altitude: 500 Ft.
Outside air temperature: 15° C
Weight: 3150 Pounds
Rate of Climb: 775 FPM

ASSOCIATED CONDITIONS:
GEAR DOWN, WING FLAPS FULL DOWN
2600 RPM & FULL THROTTLE
CLIMB SPEED 80 KIAS



BALKED LANDING CLIMB

Figure 5-31

PA-46-310P

LANDING DISTANCE OVER 50 FT. OBSTACLE

ASSOCIATED CONDITIONS:
GEAR EXTENDED, FLAPS FULL DOWN
THROTTLE CLOSED
APPROACH SPEED 77 KIAS
FULL STALL TOUCHDOWN
MAXIMUM BRAKING
PAVED LEVEL DRY RUNWAY

Example:
Pressure altitude: 2000 ft.
Outside air temperature: 12° C
Weight: 3535 pounds
Wind: None
Landing distance over 50 ft. obstacle: 1770 ft.

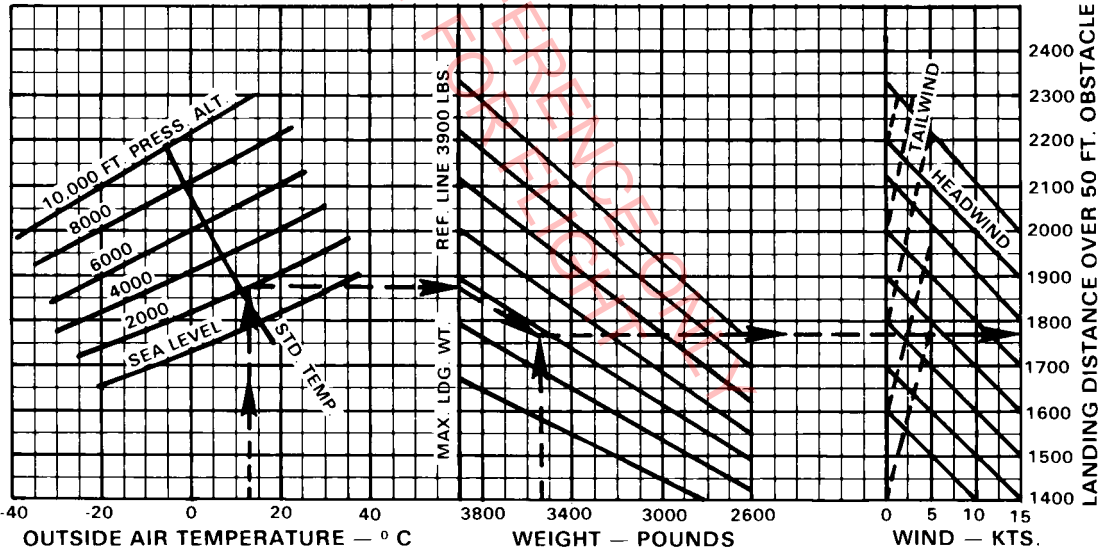

LANDING DISTANCE OVER 50 FT. OBSTACLE
Figure 5-33

LANDING GROUND ROLL

Example:

Pressure altitude: 2000 Ft.
Outside air temperature: 12° C
Weight: 3535 Pounds
Wind: none
Landing ground roll: 1025 Ft.

ASSOCIATED CONDITIONS:

GEAR EXTENDED, WING FLAPS FULL DOWN
THROTTLE CLOSED, FULL STALL TOUCHDOWN
MAXIMUM BRAKING, PAVED LEVEL DRY RUNWAY

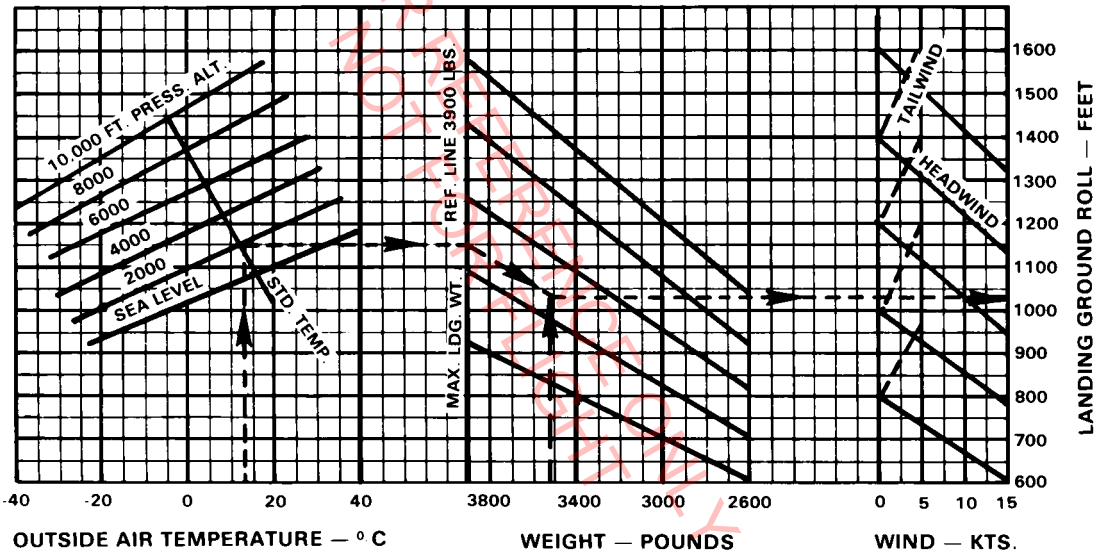

LANDING GROUND ROLL

Figure 5-35

**TABLE OF CONTENTS
SECTION 6
WEIGHT AND BALANCE**

Paragraph No.		Page No.
6.1	General	6-1
6.3	Airplane Weighing Procedure	6-2
6.5	Weight and Balance Data and Record	6-5
6.7	General Loading Recommendations	6-9
6.9	Weight and Balance Determination for Flight	6-10
6.11	Instructions for Using the Weight and Balance Plotter	6-15
	Equipment List (Form 240-0026)	Supplied with aircraft paperwork

SECTION 6
WEIGHT AND BALANCE

6.1 GENERAL

In order to achieve the performance and flying characteristics which are designed into the airplane, it must be flown with the weight and center of gravity (C.G.) position within the approved operating range (envelope). Although the airplane offers flexibility of loading, it cannot be flown with the maximum number of adult passengers, full fuel tanks and maximum baggage. With the flexibility comes responsibility. The pilot must insure that the airplane is loaded within the loading envelope before he makes a takeoff.

Misloading carries consequences for any aircraft. An overloaded airplane will not take off, climb or cruise as well as a properly loaded one. The heavier the airplane is loaded, the less climb performance it will have.

Center of gravity is a determining factor in flight characteristics. If the C.G. is too far forward in any airplane, it may be difficult to rotate for takeoff or landing. If the C.G. is too far aft, the airplane may rotate prematurely on takeoff or tend to pitch up during climb. Longitudinal stability will be reduced. This can lead to inadvertent stalls and even spins; and spin recovery becomes more difficult as the center of gravity moves aft of the approved limit.

A properly loaded airplane, however, will perform as intended. Before the airplane is licensed, a basic empty weight and C.G. location is computed (basic empty weight consists of the standard empty weight of the airplane plus the optional equipment). Using the basic empty weight and C.G. location, the pilot can determine the weight and C.G. position for the loaded airplane by computing the total weight and moment and then determining whether they are within the approved envelope.

The basic empty weight and C.G. location are recorded in the Weight and Balance Data Form (Figure 6-5) and the Weight and Balance Record (Figure 6-7). The current values should always be used. Whenever new equipment is added or any modification work is done, the mechanic responsible for the work is required to compute a new basic empty weight and C.G. position and to write these in the Aircraft Log Book and the Weight and Balance Record. The owner should make sure that it is done.

A weight and balance calculation is necessary in determining how much fuel or baggage can be boarded so as to keep within allowable limits. Check calculations prior to adding fuel to insure against improper loading.

The following pages are forms used in weighing an airplane in production and in computing basic empty weight, C.G. position, and useful load. Note that the useful load includes usable fuel, baggage, cargo and passengers. Following this is the method for computing takeoff weight and C.G.

6.3 AIRPLANE WEIGHING PROCEDURE

At the time of licensing, Piper Aircraft Corporation provides each airplane with the basic empty weight and center of gravity location. This data is supplied by Figure 6-5.

The removal or addition of equipment or airplane modifications can affect the basic empty weight and center of gravity. The following is a weighing procedure to determine this basic empty weight and center of gravity location:

(a) Preparation

- (1) Be certain that all items checked in the airplane equipment list are installed in the proper location in the airplane.
- (2) Remove excessive dirt, grease, moisture, and foreign items such as rags and tools, from the airplane before weighing.
- (3) Defuel airplane. Then open all fuel drains until all remaining fuel is drained. Operate engine on each tank until all undrainable fuel is used and engine stops. Then add the unusable fuel (2 gallons total, 1 gallon each wing).

CAUTION

Whenever the fuel system is completely drained and fuel is replenished it will be necessary to run the engine for a minimum of three minutes at 1000 RPM on each tank to insure that no air exists in the fuel supply lines.

- (4) Fill with oil to full capacity.
 - (5) Place pilot and copilot seats in fifth (5th) notch, aft of forward position. Put flaps in the fully retracted position and all control surfaces in the neutral position. Tow bar should be in the proper location and all entrance and baggage doors closed.
 - (6) Weigh the airplane inside a closed building to prevent errors in scale readings due to wind.
- (b) Leveling
- (1) With the airplane on scales, insert a 3.4-inch spacer on each of the main gear struts and a 3.0-inch spacer on the nose gear strut.
 - (2) Level airplane (refer to Figure 6-3) deflating (or inflating, as required) nose wheel tire, to center bubble on level.
- (c) Weighing - Airplane Basic Empty Weight
- (1) With the airplane level and brakes released, record the weight shown on each scale. Deduct the tare, if any, from each reading.

Scale Position and Symbol	Scale Reading	Tare	Net Weight
Nose Wheel (N)			
Right Main Wheel (R)			
Left Main Wheel (L)			
Basic Empty Weight, as Weighed (T)			

WEIGHING FORM

Figure 6-1

(d) Basic Empty Weight Center of Gravity

(1) The following geometry applies to the airplane when it is level. Refer to Leveling paragraph 6.3 (b).

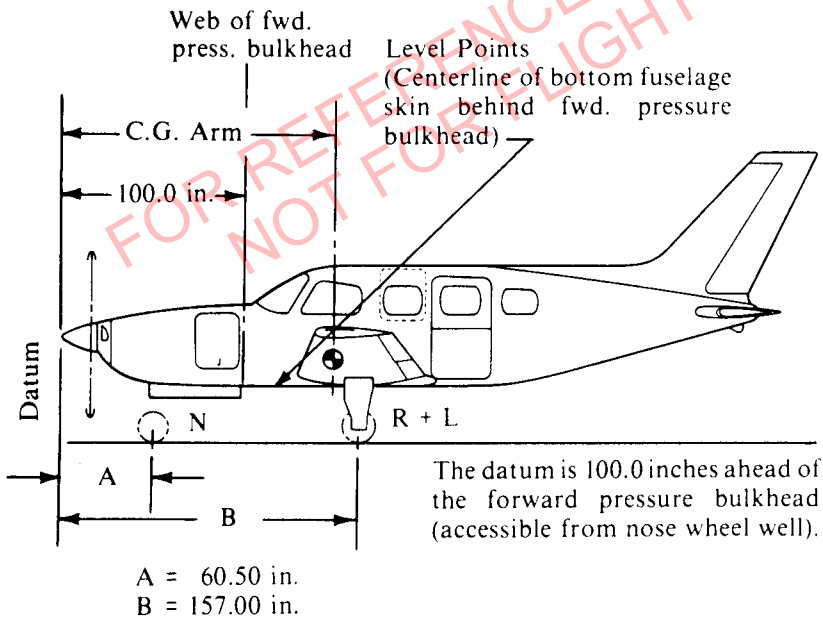

LEVELING DIAGRAM

Figure 6-3

- (2) The basic empty weight center of gravity (as weighed including optional equipment, full oil and unusable fuel) can be determined by the following formula:

$$\text{C.G. Arm} = \frac{N(A) + (R + L)(B)}{T} \text{ inches}$$

Where: $T = N + R + L$

6.5 WEIGHT AND BALANCE DATA AND RECORD

The Basic Empty Weight, Center of Gravity Location and Useful Load listed in Figure 6-5 are for the airplane as licensed at the factory. These figures apply only to the specific airplane serial number and registration number shown.

The basic empty weight of the airplane as licensed at the factory has been entered in the Weight and Balance Record (Figure 6-7). This form is provided to present the current status of the airplane basic empty weight and a complete history of previous modifications. Any change to the permanently installed equipment or modification which affects weight or moment must be entered in the Weight and Balance Record.

**SECTION 6
WEIGHT AND BALANCE**

**PIPER AIRCRAFT CORPORATION
PA-46-310P, MALIBU**

MODEL PA-46-310P MALIBU

Airplane Serial Number _____

Registration Number _____

Date _____

AIRPLANE BASIC EMPTY WEIGHT

Item	Weight (Lbs)	x	C.G. Arm (Inches Aft of Datum)	= Moment (In-Lbs)
Standard Empty Weight*	Actual			Computed
Optional Equipment				
Basic Empty Weight				

*The standard empty weight includes full oil capacity and 2.0 gallons of unusable fuel.

AIRPLANE USEFUL LOAD - NORMAL CATEGORY OPERATION

(Ramp Weight) - (Basic Empty Weight) + Useful Load

(4118 lbs) - (lbs) = lbs.

THIS BASIC EMPTY WEIGHT, C.G. AND USEFUL LOAD ARE FOR THE AIRPLANE AS LICENSED AT THE FACTORY. REFER TO APPROPRIATE AIRCRAFT RECORD WHEN ALTERATIONS HAVE BEEN MADE.

WEIGHT AND BALANCE DATA FORM

Figure 6-5

PA-46-310P		Serial Number	Registration Number			Page Number		
Date	Item No.	Description of Article or Modification	Added (+) Removed (-)	Weight Change			Running Basic Empty Weight	
				Wt. (Lb.)	Arm (In.)	Moment /100	Wt. (Lb.)	Moment /100

WEIGHT AND BALANCE RECORD
Figure 6-7

PA-46-310P		Serial Number	Registration Number				Page Number		
Date	Item No.	Description of Article or Modification	Added (+)	Removed (-)	Weight Change			Running Basic Empty Weight	
					Wt. (Lb.)	Arm (In.)	Moment /100	Wt. (Lb.)	Moment /100

NOT FOR REFERENCE ONLY

WEIGHT AND BALANCE RECORD (cont)
Figure 6-7 (cont)

6.7 GENERAL LOADING RECOMMENDATIONS

For all airplane configurations, it is the responsibility of the pilot in command to make sure that the airplane always remains within the allowable weight vs. center of gravity while in flight.

The following general loading recommendation is intended only as a guide. The charts, graphs, instructions and plotter should be checked to assure that the airplane is within the allowable weight vs. center of gravity envelope.

- (a) Pilot Only
Load rear baggage compartment first.
- (b) 2 Occupants - Pilot and Passenger in Front
Load rear baggage compartment first. Without aft baggage, fuel load may be limited by forward envelope for some combinations of optional equipment.
- (c) 3 Occupants - 2 in front, 1 in rear
Baggage in nose may be limited by forward envelope.
- (d) 4 Occupants - 2 in front, 2 in rear
Fuel may be limited for some combinations of optional equipment.
- (e) 5 Occupants - 2 in front, 1 in middle, 2 in rear
Investigation is required to determine optimum baggage load.
- (f) 6 Occupants - 2 in front, 2 in middle, 2 in rear
With six occupants fuel and/or baggage may be limited by envelope.
Load forward baggage compartment first.

For all airplane configurations, it is the responsibility of the pilot in command to make sure that the airplane always remains within the allowable weight vs. center of gravity while in flight.

6.9 WEIGHT AND BALANCE DETERMINATION FOR FLIGHT

- (a) Add the weight of all items to be loaded to the basic empty weight.
- (b) Use the Loading Graph (Figure 6-13) to determine the moment of all items to be carried in the airplane.
- (c) Add the moment of all items to be loaded to the basic empty weight moment.
- (d) Divide the total moment by the total weight to determine the C.G. location.
- (e) By using the figures of item (a) and item (d) (above), locate a point on the C.G. range and weight graph (Figure 6-15). If the point falls within the C.G. envelope, the loading meets the weight and balance requirements.
- (f) Add the fuel allowance (18 lbs.) for engine start, taxi and runup to the airplane takeoff weight determined in part (a).

FOR REFERENCE ONLY
NOT FOR FLIGHT

	Weight (Lbs)	Arm Aft Datum (Inches)	Moment (In-Lbs)
Basic Empty Weight	2645	133.70	353637
Pilot and Front Passenger	340	135.50	46070
Passengers (Center Seats)		177.0	
Passengers (Rear Seats)	340	218.75	74375
Fuel (120 Gallon Maximum Usable)	693	150.31	104165
Baggage (Forward) (100 Lb. Limit)		88.60	
Baggage (Aft) (100 Lb. Limit)	100	248.23	24823
Ramp Weight (4118 Lbs. Max.)	4118	146.45	603070
Fuel Allowance for Engine Start, Taxi & Runup	-18	150.31	-2706
Takeoff Weight (4100 Lbs. Max.)	4100	146.43	600364

The center of gravity (C.G.) for the takeoff weight of this sample loading problem is at 146.43 inches aft of the datum line. Locate this point (146.43) on the C.G. range and weight graph (Figure 6-15). Since this point falls within the weight - C.G. envelope, this loading meets the weight and balance requirements.

Takeoff Weight	4100	146.43	600364
Minus Estimated Fuel Burn-off (climb & cruise) @ 6.0 Lbs/Gal.	-350	150.31	-52609
Landing Weight	3750	146.07	547755

Locate the center of gravity of the landing weight on the C.G. range and weight graph (Figure 6-15). Since this point falls within the weight - C.G. envelope, the loading is acceptable for landing.

IT IS THE RESPONSIBILITY OF THE PILOT AND AIRCRAFT OWNER TO INSURE THAT THE AIRPLANE IS LOADED PROPERLY AT ALL TIMES.

SAMPLE LOADING PROBLEM
(NORMAL CATEGORY)

Figure 6-9

**SECTION 6
WEIGHT AND BALANCE**

**PIPER AIRCRAFT CORPORATION
PA-46-310P, MALIBU**

	Weight (Lbs)	Arm Aft Datum (Inches)	Moment (In-Lbs)
Basic Empty Weight			
Pilot and Front Passenger		135.50	
Passengers (Center Seats)		177.0	
Passengers (Rear Seats)		218.75\	
Fuel (120 Gallon Maximum Usable)		150.31\	
Baggage (Forward) (100 Lb. Limit)		88.60	
Baggage (Aft) (100 Lb. Limit)		248.23	
Ramp Weight (4118 Lbs. Max.)			
Fuel Allowance for Engine Start, Taxi & Runup	-18	150.31	-2706
Takeoff Weight (4100 Lbs. Max.)		146.43	

The center of gravity (C.G.) for the takeoff weight of this sample loading problem is at 146.43 inches aft of the datum line. Locate this point (146.43) on the C.G. range and weight graph (Figure 6-15). Since this point falls within the weight - C.G. envelope, this loading meets the weight and balance requirements.

Takeoff Weight			
Minus Estimated Fuel Burn-off (climb & cruise) @ 6.0 Lbs/Gal.		150.31	
Landing Weight			

Locate the center of gravity of the landing weight on the C.G. range and weight graph (Figure 6-15). Since this point falls within the weight - C.G. envelope, the loading is acceptable for landing.

IT IS THE RESPONSIBILITY OF THE PILOT AND AIRCRAFT OWNER TO INSURE THAT THE AIRPLANE IS LOADED PROPERLY AT ALL TIMES.

**WEIGHT AND BALANCE LOADING FORM
(NORMAL CATEGORY)**

Figure 6-11

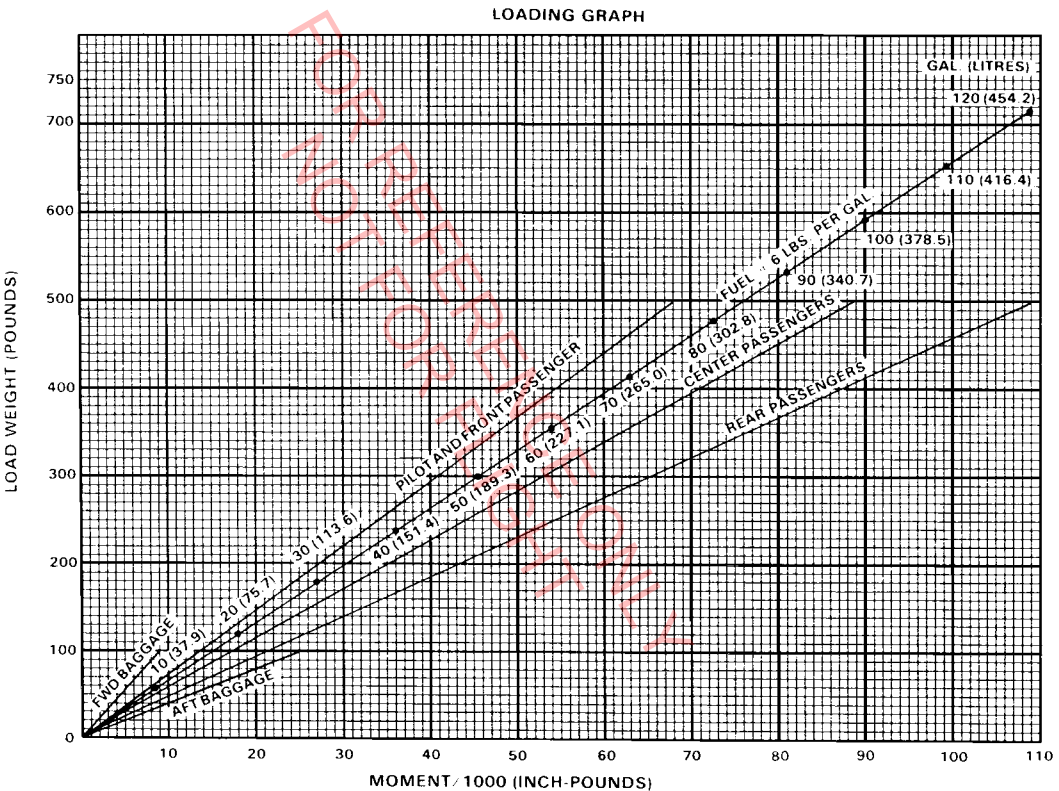

LOADING GRAPH
Figure 6-13

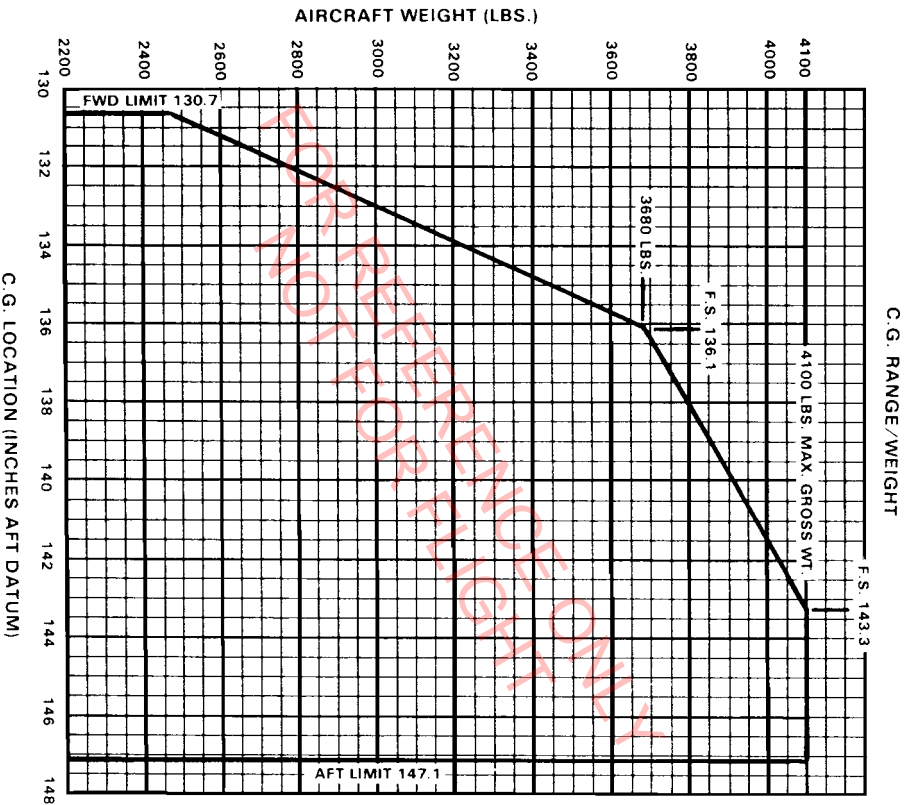

C. G. RANGE AND WEIGHT GRAPH

Figure 6-15

6.11 INSTRUCTIONS FOR USING THE WEIGHT AND BALANCE PLOTTER

This plotter is provided to enable the pilot quickly and conveniently to:

- (a) Determine the total weight and C.G. position.
- (b) Decide how to change his load if his first loading is not within the allowable envelope.

Heat can warp or ruin the plotter if it is left in the sunlight. Replacement plotters may be purchased from Piper dealers and distributors.

The "Basic Empty Weight and Center of Gravity" location is taken from the Weight and Balance Form (Figure 6-5), the Weight and Balance Record (Figure 6-7) or the latest FAA major repair or alteration form.

The plotter enables the user to add weights and corresponding moments graphically. The effect of adding or disposing of useful load can easily be seen. The plotter does not cover the situation where cargo is loaded in locations other than on the seats or in the baggage compartments.

Brief instructions are given on the plotter itself. To use it, first plot a point on the grid to locate the basic weight and C.G. location. This can be put on more or less permanently because it will not change until the airplane is modified. Next, position the zero weight end of any one of the loading slots over this point. Using a pencil, draw a line along the slot to the weight which will be carried in that location. Then position the zero weight end of the next slot over the end of this line and draw another line representing the weight which will be located in this second position. When all the loads have been drawn in this manner, the final end of the segmented line locates the total load and the C.G. position of the airplane for takeoff. If this point is not within the allowable envelope it will be necessary to remove fuel, baggage, or passengers and/or to rearrange baggage and passengers to get the final point to fall within the envelope.

Gear movement does not significantly affect the center of gravity.

SAMPLE PROBLEM

A sample problem will demonstrate the use of the weight and balance plotter. Assume a basic weight and C.G. location of 2645 pounds at 133.70 inches respectively. We wish to carry a pilot and three passengers: the pilot and one passenger will occupy the front seats, and the other two passengers will occupy the rear seats. Each occupant weighs 170 pounds. We wish to carry 100 pounds of baggage in the rear baggage compartment and 75 gallons of fuel. Will we be within the safe envelope?

- (1) Place a dot on the plotter grid at 2645 pounds and 133.70 inches to represent the basic airplane (see illustration).
- (2) Slide the slotted plastic into position so that the dot is under the slot for the forward seats, at zero weight.
- (3) Draw a line up the slot to the 340 pound position ($170 + 170$) and put a dot.
- (4) Move the slotted plastic again to get the zero end of the rear seat slot over this dot.
- (5) Draw a line up this slot to the 340 pound position ($170 + 170$) and place the third dot.
- (6) Continue moving the plastic and plotting points to account for weight in the rear baggage compartment (100 pounds) and in the fuel tanks (450 pounds; 75 gallons).
- (7) As can be seen from the illustration, the final dot shows the total weight to be 3875 pounds with the C.G. at 146.2. This is well within the envelope.
- (8) Fuel allowance for engine start, taxi and runup is 18 pounds.

As fuel is burned off, the weight and C.G. will follow down the fuel line and stay within the envelope for landing.

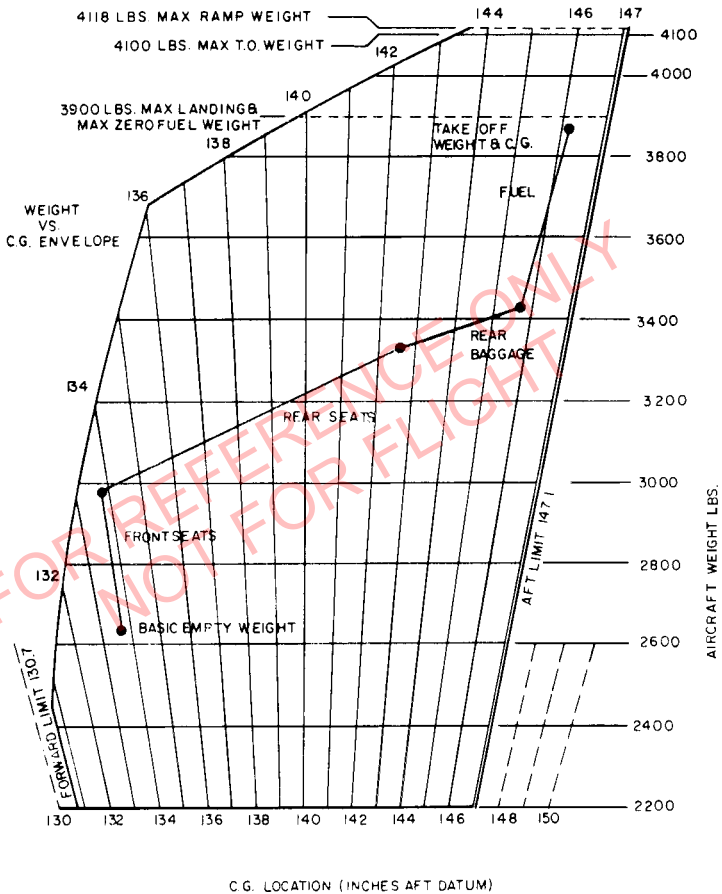

SAMPLE PROBLEM
 Figure 6-17

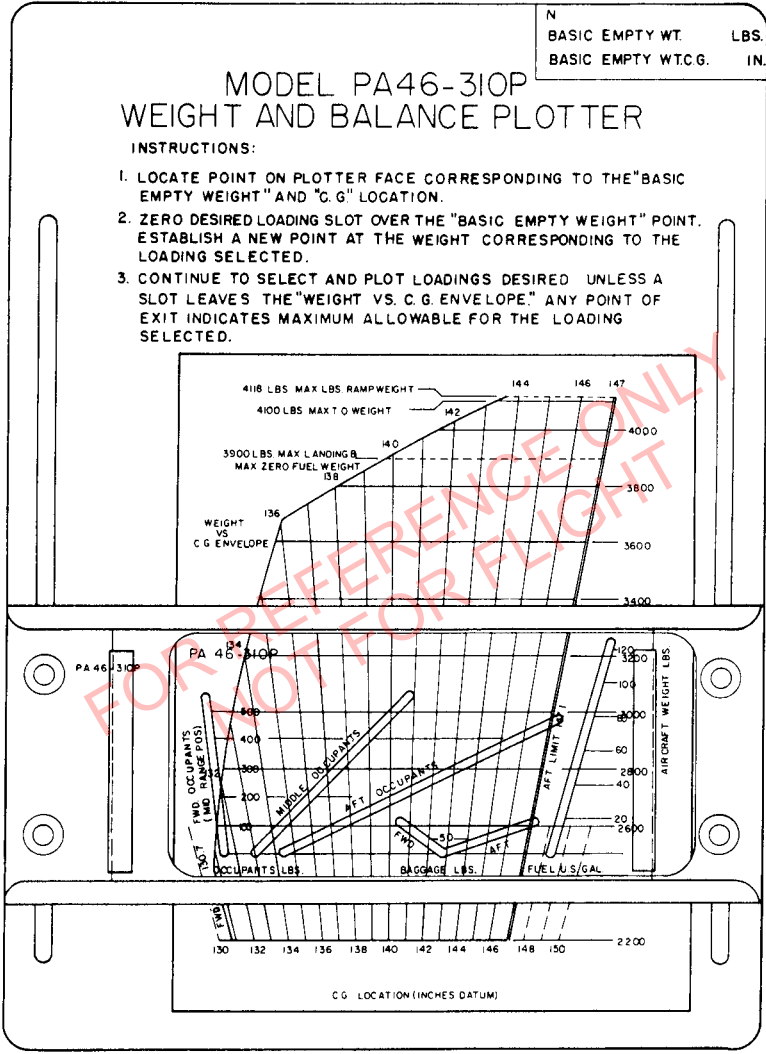

WEIGHT AND BALANCE PLOTTER
Figure 6-19

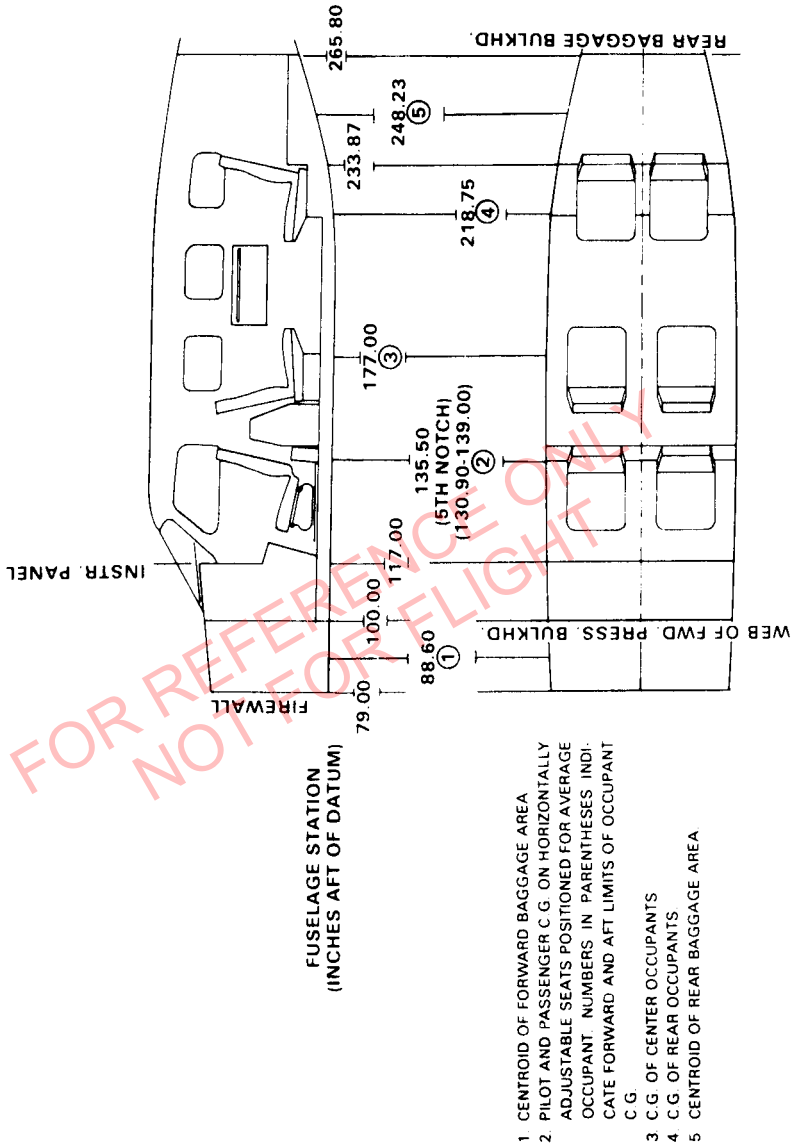

LOADING ARRANGEMENTS

Figure 6-21

TABLE OF CONTENTS

SECTION 7

**DESCRIPTION AND OPERATION
OF THE AIRPLANE AND ITS SYSTEMS**

Paragraph No.		Page No.
7.1	The Airplane.....	7-1
7.3	The Airframe.....	7-1
7.5	Engine and Propeller.....	7-2
7.6	Air Induction System.....	7-6
7.7	Engine Controls.....	7-6
7.9	Hydraulic System.....	7-9
7.11	Landing Gear.....	7-11
7.13	Brake System.....	7-14
7.15	Flight Control System.....	7-14
7.17	Fuel System.....	7-15
7.19	Electrical System.....	7-20
7.21	Instrument Panel.....	7-26
7.23	Pitot Static System.....	7-30
7.25	Environmental System.....	7-32
7.27	Bleed Air, Conditioning & Pressurization System.....	7-34
7.29	Vacuum System (Standard).....	7-37
7.31	Cabin Features.....	7-41
7.33	Baggage Area.....	7-43
7.35	Finish.....	7-43
7.37	Stall Warning.....	7-43
7.39	Emergency Locator Transmitter.....	7-44
7.41	External Power.....	7-45
7.43	Radar.....	7-45

SECTION 7

DESCRIPTION AND OPERATION OF THE AIRPLANE AND ITS SYSTEMS

7.1 THE AIRPLANE

The PA-46-310P Malibu is a single engine, all metal, retractable landing gear, low wing, turbocharged airplane. It has a pressurized cabin with seating for six occupants and two separate luggage compartments.

7.3 THE AIRFRAME

The primary airframe is of aluminum alloy construction, with a steel combination engine mount - nose gear support structure. The nose cowl and rear section of the dorsal fairing are fiberglass.

The fuselage is an all metal, semi-monocoque structure with flush riveted skin. The skin has internally bonded doublers and is butt jointed at all seams not in the airflow direction. There are three basic fuselage sections: the forward baggage section, the pressurized cabin section, and the tail cone section. The cabin section is sealed to maintain pressurization.

The seating arrangement includes two crew seats and four passenger seats. The forward passenger seats face aft, and all passenger seats have adjustable backs with built-in headrests. An inside baggage area is provided aft of the rear passenger seats.

Cabin access is through the main cabin door, located on the left side, aft of the wing. The main door is a horizontally split door with retractable steps in the lower half. The upper half is held open by a gas spring. A plug type, inward releasing, emergency egress door is located on the right side adjacent to the aft facing seat.

Windows include a two-piece windshield, pilot and copilot windows, a storm window in the pilot's window, and three passenger windows on each side.

The forward baggage compartment is unpressurized and has a locking door on the left side, forward of the wing.

The wing is in effect a three section structure. The center section built-up main spar extends through the lower fuselage and outboard of each main landing gear. This section has a forward spar and a rear spar which are pin jointed at the fuselage sides. The main landing gear retracts inward into recesses located aft of the main spar. The outboard section of each wing, to within approximately 18 inches of the tip, is a sealed integral fuel cell. Portions of the wing structure are adhesively bonded, and skins are butt jointed and flush riveted for a smooth airfoil surface.

The all-metal flaps are electrically actuated through a mechanical linkage. The flaps extend aft and down on three tracks and have four preselect positions.

The all-metal ailerons are mass balanced and operated by a cable system mounted on the aft wing spar.

The empennage is of conventional fin and rudder, stabilizer and elevator design with aerodynamic and mass balanced control surfaces. Surfaces are of all-metal construction and the single-piece elevator assembly carries a center-mounted trim tab. This tab operates to combine anti-servo and trim functions.

Various access panels on the fuselage, wings and empennage are removable for service or inspection purposes.

Electrical bonding is provided to ensure good electrical continuity between components. Lightning strike protection is provided in accordance with presently accepted practices. Anti-static wicks are provided on trailing edges of ailerons, elevator and rudder to discharge static electricity that might cause avionics interference.

7.5 ENGINE AND PROPELLER

ENGINE

The Malibu is powered by a Teledyne Continental TSIO-520-BE engine. It is a direct drive, horizontally opposed, overhead valve, fuel injected, air cooled, turbocharged-aftercooled with variable waste gate, sloped control system. Maximum rated power is 310 HP 2600 RPM and 38 in. Hg.

manifold pressure. Accessories normally installed include one gear-driven alternator, a propeller governor, two magnetos, an oil filter, an air/oil separator, a starter and one gear-driven vacuum pump. Optional accessories include a second belt-driven alternator, a second gear-driven vacuum pump, and a belt-driven air conditioning compressor.

Turbocharging is accomplished by two Garrett - A.I.D. turbo-compressors, one located on each side of the engine. Turbochargers extract energy from engine cylinder exhaust gases and use this energy to compress engine induction air. This allows the engine to maintain rated power at altitude. When engine induction air is compressed by the turbocharger, the air temperature is increased. The elevated air temperature is reduced by air aftercoolers located on each side of the engine. This aids in engine cooling and improves engine power and efficiency.

Each turbocharger extracts exhaust energy from its respective bank of cylinders to pressurize the induction air. Air flows through the induction inlet louvers into the induction air box, where it is filtered and divided for distribution to the left and right turbo compressors. At the compressor, air pressure and temperature are increased. Pressure increases air density making a greater mass of air available to the engine cylinders on each intake stroke. Air then flows through an aftercooler where air temperature is reduced, further increasing the density of air available to each cylinder. Downstream the aftercoolers, air flow joins at the "Y" junction of intake tubes on the top front of the engine, then passes the throttle butterfly valve and is divided to individual intake pipes flowing to each cylinder. Metered fuel is injected into the cylinder head, upstream of the intake valve. After the fuel burns in the cylinder, exhaust gases flow into the exhaust manifold and then to turbocharger turbines where exhaust energy is extracted to drive the compressor.

Turbo compressed air is throttled across the throttle butterfly valve as set by the throttle lever. A sloped control system monitors pressure differential and uses engine oil pressure to automatically position the waste gate valve. The waste gate bleeds excess exhaust gas from the exhaust manifold crossover pipe and out the left exhaust stack, bypassing the turbocharger. Thus the controller automatically maintains manifold pressure.

The engine is well protected against overboost damage from excessive manifold pressure. The waste gate controller senses manifold pressure and will continually adjust turbocharger output, maintaining the manifold pressure set by the throttle. The controller automatically protects the engine

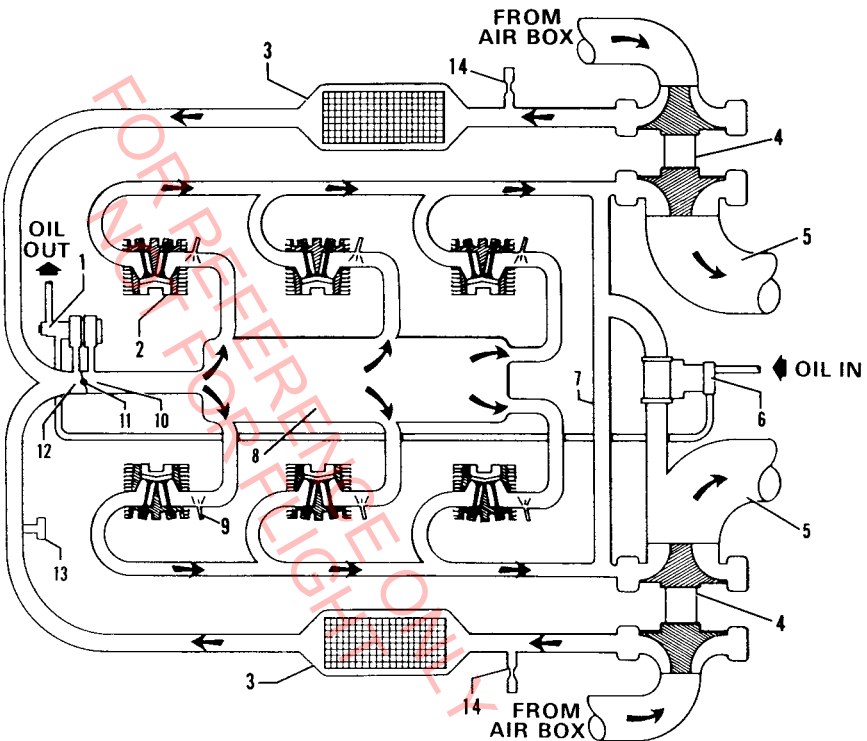

TURBO-INDUCTION SYSTEM

Figure 7-1

from overboost damage by limiting manifold pressure to 38 in. Hg. In the event of a controller malfunction, there is a pressure relief valve on the induction manifold which will relieve manifold pressure at 42 in. Hg.

Manifold pressure limits can be exceeded with full throttle operation during certain off standard ambient conditions and low engine oil temperature. During such conditions limit manifold pressure to 38 in. Hg maximum.

When descending from altitude, care should be exercised to maintain engine power and temperatures (oil, CHT). Turbocharger compressors supply air for cabin pressurization and power reduction below that recommended could cause a decrease in cabin pressure. Sudden cooling or gradual extreme cooling of engine cylinders will accelerate engine wear. Follow normal descent procedures described in Section 4.

The fuel injection system has four basic components and one continually moving part in the fuel pump. The primary functions of the engine driven pump include supplying fuel under pressure to the injection system and performing certain metering functions. The metering unit controls the proportioning of fuel to air. The manifold valve divides metered fuel flow equally between the six nozzles in the system. The nozzles continuously spray and atomize metered fuel into the intake valve port of the engine cylinder head.

Fuel is supplied to the engine driven pump at a greater rate than required. The excess is returned to the wing tank selected.

To assist engine starting, an injection primer button can be found to the right of the starter button, just left of the pilot's control column. The primer system diverts a large percentage of fuel intended for injection nozzles into the intake manifold pipes through a single primer nozzle, just aft and downstream of the throttle valve.

Engine oil sump capacity is 8 quarts. Maximum endurance flights should begin with 8 quarts of oil. Oil is drawn from the sump through a suction tube to the intake side of the engine driven oil pump. Outlet oil is directed to a full-flow, replaceable-element oil filter. A bypass valve incorporated in the filter opens in the event it becomes clogged. The oil pump has an oil pressure relief valve in the housing. A second gear-driven pump, located below the starter, scavenges oil from the turbochargers. Engine oil is cooled by ram air passing through the oil cooler on the left rear of the engine. Oil is distributed throughout the engine, providing lubrication, cooling, and oil to the propeller governor and turbocharger waste gate. Oil

temperature and pressure information is available from the combination gauge on the lower right of the pilot's instrument panel. Engine crankcase gases are discharged to an air/oil separator behind the oil cooler and then vented out the left exhaust stack.

PROPELLER

The propeller is a Hartzell, all metal, two blade, constant speed unit with an 80-inch diameter. Constant propeller rotational speed (RPM) is maintained by a balance of air load and engine rotational forces. The Hartzell propeller governor, mounted on the left front of the engine, pressurizes and regulates the flow of engine oil to a piston in the propeller dome. The piston is linked by a sliding rod and fork arrangement to propeller blades. Governor oil pressure against the piston works to increase propeller blade pitch, thus decreasing propeller and engine RPM. Centrifugal twisting moments on the propeller blades work to decrease propeller blade pitch and increase RPM. Simple control of the interaction of these and other forces to maintain a constant RPM is provided by the propeller control lever in the cockpit.

The propeller control lever, linked by cable to the propeller governor, determines a wide range of in-flight RPM. Governor range is more limited during ground operation. Pushing the lever forward selects increased or higher RPM. Pulling the lever aft selects decreased or lower RPM. When in flight the RPM should not fluctuate significantly from that set, regardless of throttle setting.

The propeller may be operated within the full range of RPM indicated by the tachometer, up to the red radial line. In cruise, always use the power setting charts provided. Avoid exceeding maximum RPM and excessive engine stress by moving propeller and throttle levers in smooth deliberate motions. On cold days during run-up, exercise the propeller several times to flow warm oil into the propeller hub. This assures propeller governing for takeoff.

7.6 AIR INDUCTION SYSTEM

CAUTION

Alternate air is unfiltered. Use of alternate air during ground or flight operations when dust or other contaminants are present may result in engine damage from particle injection.

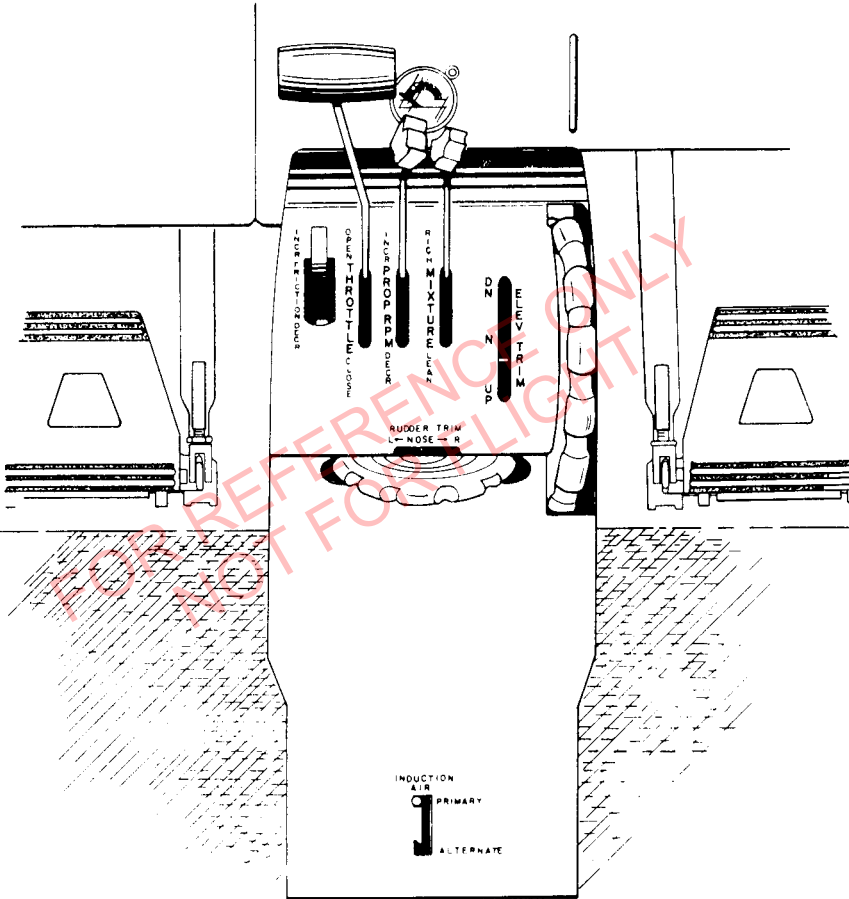

CONTROL PEDESTAL
Figure 7-3

7.6 AIR INDUCTION SYSTEM (Continued)

The engine air induction system receives ram air through forward facing ram air louvers located on the lower cowl below the propeller. Air enters these louvers and flows through a removable air filter mounted adjacent to the louvers. The filter removes dust and other foreign matter from the induction air. However, in the event the ram air louvers or the filter should become obstructed by ice or other causes, the pilot must manually select alternate air to provide air to the engine. This alternate air control is located on the center console just below engine control quadrant. When the induction air lever is up, or on primary air, the engine is operating on filtered air drawn through the forward facing ram air louvers. When the lever is down, or on alternate air, the engine is operating on unfiltered air, drawn through the aft facing louvers immediately aft of the ram air louvers. Since the alternate air bypasses the air filter, alternate air should never be used during ground operations, except for checking its operation.

Application of alternate air will result in a loss of manifold pressure when operating with a combination of high altitude and low RPM where the turbocharger wastegate is closed. Loss of manifold pressure of up to 8 inches Hg can result at maximum continuous power, with a possible greater reduction resulting at cruise power settings. Some of this manifold pressure loss may be recovered with throttle and / or RPM adjustment.

7.7 ENGINE CONTROLS

The engine is controlled by throttle, propeller and mixture control levers, located on the control quadrant on the lower central instrument panel. The controls utilize teflon-lined control cables to reduce friction and binding.

The throttle lever is used to control engine power by moving the butterfly valve in the fuel-air control unit, thus adjusting manifold pressure. The throttle lever incorporates a gear-up warning horn switch, which is activated during the last portion of travel of the throttle lever to the low power position. If the landing gear is not locked down, the horn will sound until the gear is down and locked, or until the power setting is increased. This is a safety feature to warn the pilot of an inadvertent gear-up landing. All throttle operations should be made with a smooth, deliberate movement to prevent unnecessary engine wear or damage and to allow time for the turbocharger speed to stabilize.

The propeller control lever is used to adjust engine speed (RPM) at the propeller governor. Propeller speed controls power availability, which is increased by increasing RPM when the lever is moved forward. The lever is moved aft to reduce RPM. Propeller operations should be smooth and deliberate to avoid unnecessary wear.

The mixture control lever is used to adjust the fuel-to-air ratio at the fuel-air control unit. Full forward is rich mixture. Normal engine shutdown is accomplished by placing the mixture in the idle cutoff position.

The friction adjustment lever, located on the far left of the control quadrant, may be adjusted to increase or decrease the friction holding the throttle, propeller and mixture controls.

7.9 HYDRAULIC SYSTEM

The hydraulic system (refer to Figure 7-5) provides the power to retract and extend the landing gear.

The electric motor driven hydraulic pump assembly is located aft of the rear baggage compartment and is accessible through the baggage compartment aft closeout panel. The pump assembly has an integral reservoir with filler plug, sight gauge and vent. The pump assembly incorporates pressure switches, bypass relief valves, and thermal relief valves in both the UP and DOWN sides. A shuttle valve is also incorporated to allow for unequal volumes of hydraulic fluid displaced during UP and DOWN gear actuation. Normal system operating pressure is controlled by the pressure switches. Maximum system operating pressure is limited by the bypass relief valves, and maximum system holding or trapped pressure is limited by the thermal relief valves.

The motor which drives the hydraulic pump is reversible and runs in one direction to supply gear UP pressure and in the opposite direction to supply gear DOWN pressure. The direction in which the pump runs is controlled electrically by the position of the gear selector switch on the instrument panel.

Other major components of the hydraulic system are the three gear actuators and the emergency gear extension valve. Operation of these components is covered in the landing gear section.

3571

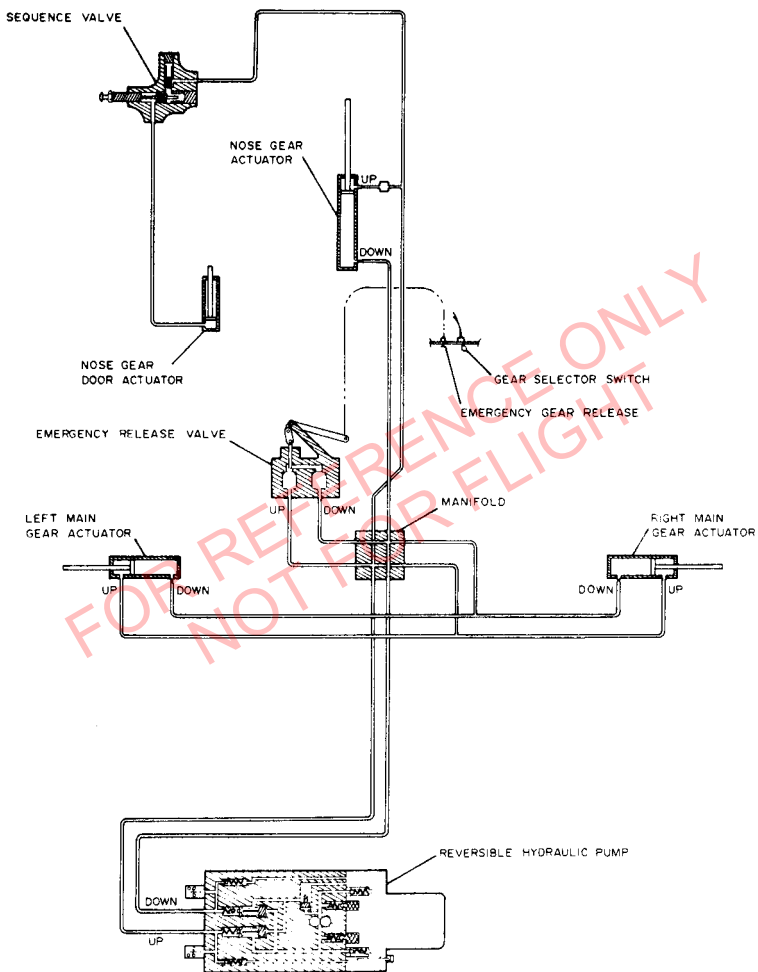

HYDRAULIC SYSTEM

Figure 7-5

7.11 LANDING GEAR

The aircraft is equipped with hydraulically operated, fully retractable, tricycle landing gear.

Locking-type actuators are used for main and nose gears. The actuator assembly provides mechanical gear-down locking at the fully extended position and is hydraulically unlocked. The actuator also acts as the gear brace in the extended position.

The main gear retracts inboard into the wing root area. A mechanically linked door covers the strut assembly.

Hydraulic pressure for gear operation is furnished by an electrically driven hydraulic pump (refer to Figures 7-5 and 7-9). Gear operation is initiated by a two position selector with a wheel shaped knob located to the left of the engine control quadrant (Figure 7-7). Three green lights, which are individually activated as each gear mechanically locks into the DOWN position are located above the landing gear selector. The landing gear selector knob must be pulled outward to release it from a detent in the DOWN position prior to moving it to the UP position. In addition, there is a "squat" switch on the left main gear which prevents operation of the gear UP electrical circuit when the aircraft weight is on the gear. If the landing gear selector is placed in the UP position with the aircraft weight on the gear, the gear warning horn will sound, and the red GEAR WARNING annunciator will illuminate.

The landing gear is held in the UP position by hydraulic pressure which is trapped in the system UP lines by a check valve in the pump assembly. When normal pump operation is stopped by the pressure switch, a check valve in the pump assembly closes to trap fluid pressure in the UP side of the system. Emergency gear extension is accomplished by a manually actuated valve which relieves the pressure in the UP side and bypasses fluid to the DOWN side of the system. The additional fluid required for DOWN operation comes directly from the reservoir.

The landing gear is held in the DOWN position by spring loaded mechanical locking mechanisms built into each of the three actuating cylinders. The individual gear safe light switches are also mechanically operated when each mechanism is in the LOCKED position. With the hydraulic pump and system operating normally, hydraulic pressure is also trapped in the DOWN side of the system. This DOWN pressure is not required to mechanically lock the cylinders and is not available if the hydraulic pump is inoperative.

The EMERGENCY GEAR extension system allows the landing gear to free fall, with spring assist on the nose gear, into the extended position where the mechanical locks engage. Approximately 25 pounds of force is required to pull the EMERGENCY GEAR extension control. If a gear system malfunction has been indicated and the EMERGENCY GEAR extension system used, it is recommended that the EMERGENCY GEAR extension control and the HYD PUMP circuit breaker be left in the pulled position until the aircraft is safely on jacks. See the Service Manual for proper landing gear system check-out procedures. If the aircraft is being used for training purposes or a pilot check-out flight the EMERGENCY GEAR extension control and HYD PUMP circuit breaker must be reset in order for hydraulic pressure to be generated in the UP side of the system and the gear retracted.

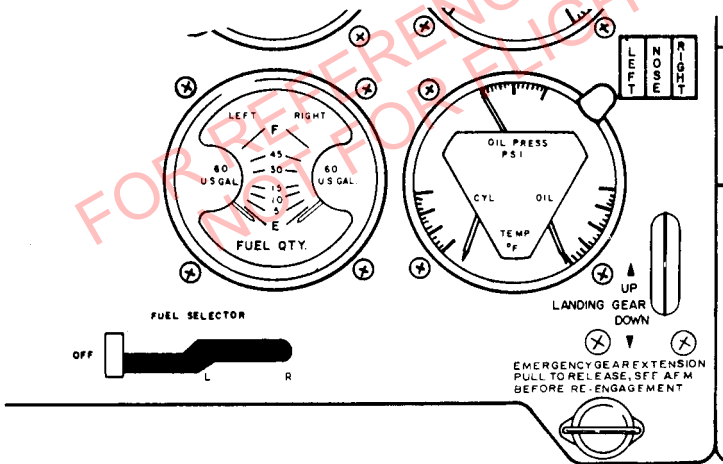

LANDING GEAR SELECTOR

Figure 7-7

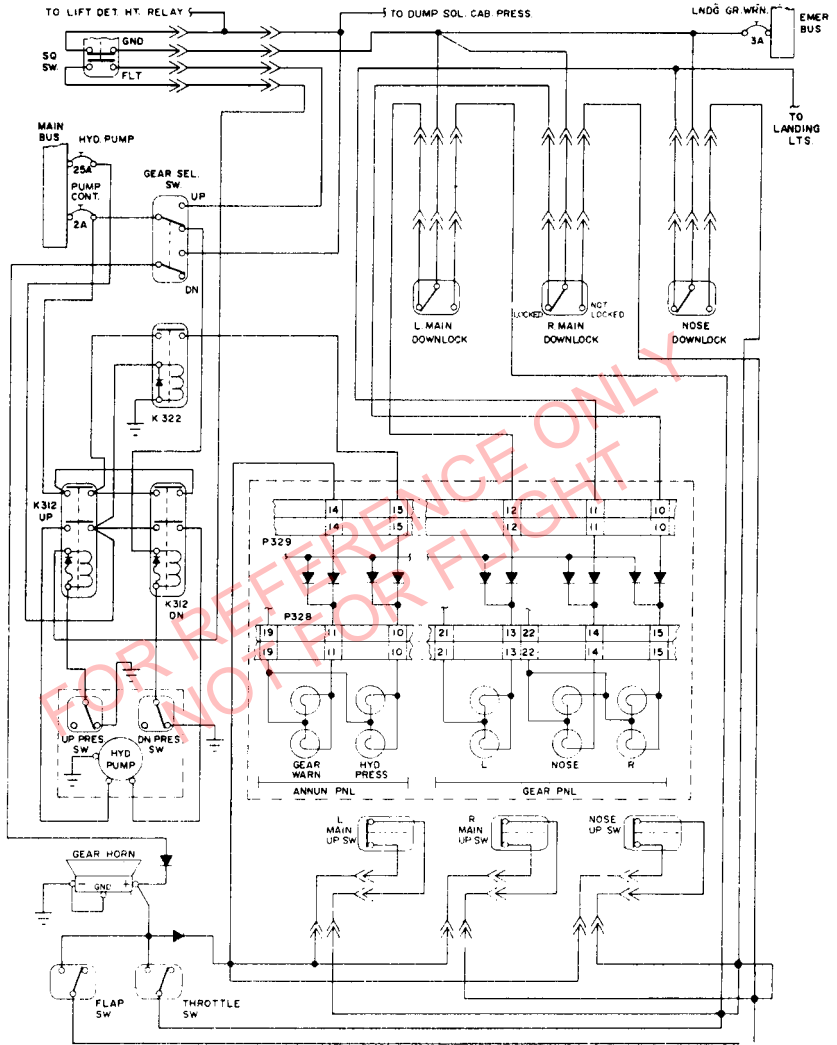

NOTE
GEAR SHOWN DOWN
AND LOCKED WITH
WEIGHT ON WHEELS

LANDING GEAR ELECTRICAL DIAGRAM

Figure 7-9

The annunciator panel contains two lights pertaining to landing gear operation. A red GEAR WARNING annunciator is activated whenever all three gears are not fully down and locked, or not fully up with the gear doors closed. This annunciator comes on during normal gear operation to indicate that the gear is in transit. If it does not go out within approximately 10 seconds during normal gear operation or illuminates steadily during flight with the landing gear selector in the UP position, a system malfunction is indicated. There is also an amber HYD PUMP annunciator which indicates that the hydraulic pump motor is being supplied with electrical power. The annunciator is illuminated during normal landing gear operation for approximately the same duration as the GEAR WARNING annunciator. If the light remains on or begins cycling intermittently after gear operation, a system malfunction is indicated.

7.13 BRAKE SYSTEM

The brake system is designed to meet all normal braking needs. Two single-disc, double puck brake assemblies, one on each main gear, are actuated by toe brake pedals mounted on both the pilot's and copilot's rudder pedals. A brake system reservoir, independent of the hydraulic system reservoir, is located behind the aft access panel in the forward baggage compartment. Brake fluid should be maintained at the level marked on the reservoir. For further information see "Brake Service" in Section 8 of this handbook.

The parking brake knob is located just below the left control column. To set the parking brake, first depress and hold the toe brake pedals and then pull the parking brake knob. To release the parking brake, first depress and hold the toe brake pedals and then push in on the parking brake knob.

WARNING

No braking will occur if aircraft brakes are applied while parking brake handle is pulled and held.

7.15 FLIGHT CONTROL SYSTEM

The primary flight controls are conventional and are operated by dual control wheels and rudder pedals. The control wheel operates the ailerons and elevator. The rudder pedals actuate the rudder and nose wheel steering. The toe brakes, which are an integral part of the pedals, operate the wheel brakes. The ailerons and rudder are interconnected through a spring system, which is activated only when controls are out of harmony. In normal coordinated flight the system is inactive. All flight control systems are operated by closed circuit cable systems.

Secondary control is by elevator and rudder trim. The controls are located on the pedestal (Figure 7-3). Aileron trim is provided by a fixed, ground-adjustable tab. The elevator trim control wheel is located on the right side of the pedestal. The wheel is rotated forward for nose-down trim and aft for nose-up trim. The rudder trim wheel is located on the aft face of the pedestal. The wheel is rotated to the right (counterclockwise) for nose right and left (clockwise) for nose left. Trim indications for the individual systems are located on the pedestal.

The wing flaps are electrically controlled by a selector lever mounted on the instrument panel immediately to the right of the control pedestal. The flap position indicator is located to the left of the selector lever. The flaps may be set to four positions; up (0°), 10°, 20°, and full down (36°). Each position is detented on the flap selector panel. The flaps will automatically move to the selected position, and the indicator will display the actual flap position. The flaps may be extended to 10° at airspeeds below 170 KIAS, 20° below 135 KIAS, and 36° flap extension is limited to airspeeds below 120 KIAS. A FLAPS annunciator light is provided as part of the annunciator panel located in the upper portion of the pilots instrument panel. If the annunciator light illuminates, it is indicative of a system malfunction in which case the flap protection circuit automatically removes power from the electric flap motor. Resetting of the FLAP WARN/RESET circuit breaker will restore normal operating power to the flap motor. If, after resetting, and operation of the flaps, the annunciator illuminates again then a system malfunction is indicated and the flap motor circuit breaker should be pulled.

7.17 FUEL SYSTEM

Fuel is stored in two main integral wing tanks (see Figure 7-11), located outboard of the mid-wing splice. Fuel quantity held by each wing tank is 60 usable gallons with one gallon of unusable fuel, for a total of 122 gallons. The minimum fuel grade is 100 or 100LL aviation grade. Each tank gravity feeds fuel through finger screens into three lines leading to collector/sump tanks located at the root of each wing, just aft of the main spar. During preflight the collector/sump tank and one of the three lines can be inspected

in each main wheel well. Collector/sump tanks vent back to the main tanks by a fourth line located forward of the main spar. The main tanks vent to the atmosphere by non-icing vents installed in the most outboard forward access panels of each wing tank. Reverse fuel flow from collector tanks to main tanks is prevented by 2 flapper check valves installed in each collector tank. Collector tank sumps are the lowest points in the fuel system, and each has a drain valve for draining collector and main tanks.

WARNING

Avoid prolonged uncoordinated flight to prevent uncovering of fuel tank outlets and subsequent fuel starvation.

Each tank separately vents air in and fumes out to equalize pressure with ambient conditions. This is accomplished through combination valves in non-icing fuel tank vents located at the most outboard, forward tank access panels.

NOTE

When opening the fuel tank filler cap, a rush of air will normally be heard and felt. This is caused by the large volume of vapor space in the wing tank, which is under a slight pressure differential. This pressure is the minimum required to open the combination valve in the vent and does not represent a hazard.

CAUTIONS

Do not insert objects into the wing vent as damage to the combination valve could result in fuel leakage.

A plugged vent could result in fuel starvation. If a restricted vent is suspected, select the opposite tank immediately. Monitor the suspect wing and land as soon as possible.

Fuel quantity is indicated by gauges located above the fuel selector handle. Each tank has two sensor sending units. Gauges are electrical and will operate when the battery switch is ON. Fuel tanks can be visually confirmed full if fuel level is up to the filler neck.

NOTE

Removal of the fuel filler cap from a wing tank that is sitting low or from an overfilled tank caused by thermal expansion could result in fuel spillage.

Quantity gauges should be monitored at regular intervals during flight. Fuel tank selection should be alternated accordingly to maintain wing balance.

NOTE

Aircraft should be refueled in a wings level condition. At times, this will require alternate filling of left and right tanks until the full condition is reached.

Each collector/sump tank has a submerged, electric, centrifugal fuel pump having 2 speed selections available through a switch on the instrument panel. LOW speed is intended for vapor suppression at altitude and may be used during normal engine operation both on the ground and in flight. Unstable engine operation or fluctuating fuel flow indications are signs of vapor in the fuel lines.

The HIGH pump speed selection on the instrument panel should be used only in the event of engine failure if an engine-driven pump failure is suspected. Adequate pressure and fuel flow will be supplied for up to approximately 75% power.

NOTE

Excessive fuel pressure and very rich fuel/air mixtures will occur if the HIGH position is energized when the injection system is functioning normally.

The fuel pump will run at high speed automatically when the engine primer is being used. Selection of left or right auxiliary fuel pump is determined at the fuel selector by moving the selector handle to the left or right tank. Neither pump will operate if OFF or a position between detents is selected on the fuel selector.

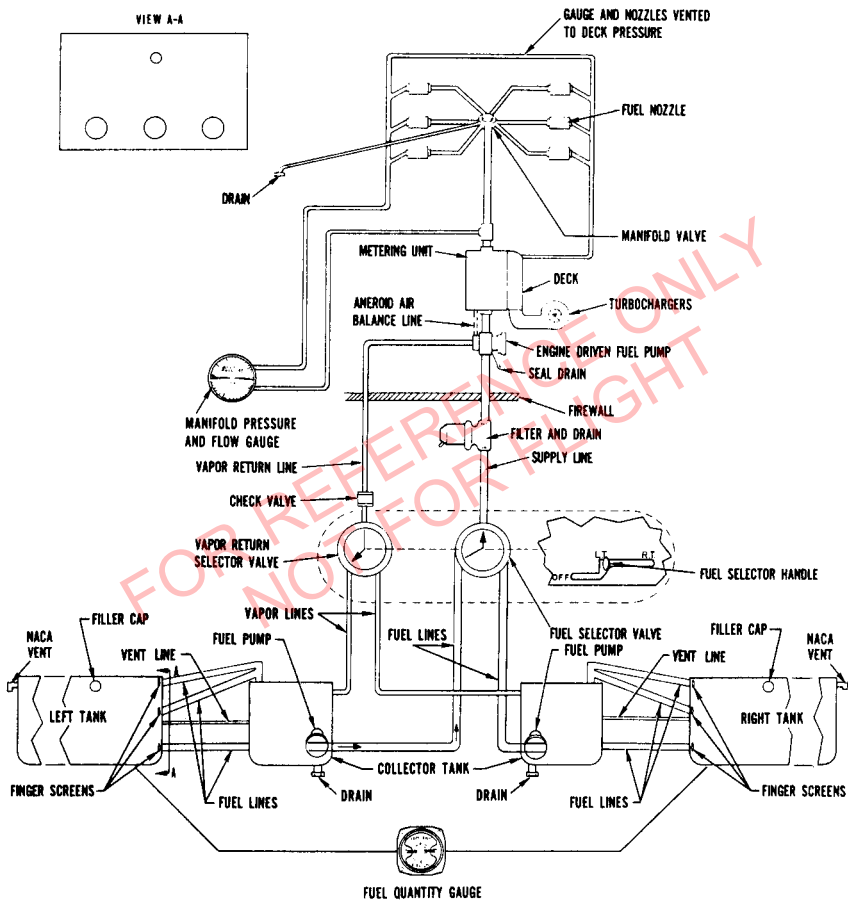

FUEL SYSTEM SCHEMATIC

Figure 7-11

Fuel leaving the left or right collector/sump tank flows to a selector valve which is located on the right fuselage side behind the co-pilot's seat in a non-pressurized compartment. All fuel lines passing through the pressurized cabin are metal tubes surrounded by plastic cushion and encased by a second metal tube. This second tube is sealed from the cabin environment to preclude fuel from entering the cabin area or pressurized cabin air from entering fuel lines in the event of a leak.

The selector valve is cable controlled by a thumbsized handle just below the fuel quantity gauges. The detented selections are OFF, LEFT, RIGHT. LEFT or RIGHT positions direct fuel flow to the engine from the tank selected and route engine vapor return back to the same tank. To select OFF the fuel selector must be moved to the left tank position, moved down against spring pressure, then moved to the far left, or OFF position.

Fuel flows from the fuel selector forward to the fuel filter located below the baggage floor on the right side. The filter drain is a nylon tube located on the right side of the aircraft, forward of the wing. To drain fuel simply push in the nylon tube. If contaminants clog the filter, an internal relief valve will allow fuel to bypass the filter. This will allow unfiltered fuel to reach the engine and could contaminate the fuel distribution system in the engine.

NOTE

Regular servicing of the filter and examination of fuel samples for contamination is required.

Fuel flows from the filter, forward through the fire wall and into the engine compartment, where lines and fittings up to the engine-driven pump are protected by shielding. One shield protecting lines and fittings attached to the fire wall has a tube drain on the right side of the cowl between the exhaust fairing and the nose gear door.

WARNING

Do not start the engine with fuel leaking from the shielding tube drain. Fuel here indicates a possible leak in main fuel or vapor return lines in the engine compartment.

In the engine-driven fuel pump, vapor in the fuel is separated for return to the selected tank. Vapor lines generally run parallel with fuel lines. A vapor return check valve is located below the baggage compartment near the

fuel filter. This valve prevents reverse flow of vapor back to the engine. Vapor is returned to the selected collector/sump tank where it flows by buoyancy through the vent line to the selected main tank.

When established in the cruise configuration, the mixture should be leaned. See Section 4 for proper leaning procedure. This aircraft flies most efficiently with a balanced fuel load in the wing, requiring minimal aileron force to keep the wing level. As the flight progresses, the pilot should endeavor to maintain a schedule, monitoring fuel gauges and switching fuel tanks as required. Fuel cannot be used from both tanks simultaneously.

The pilot should monitor the fuel flow as this gauge may provide the first indication of fuel vaporization. Activation of the auxiliary fuel pump on the LOW setting will eliminate vapor formation that is associated with high altitude.

Unusable fuel quantity for this aircraft is one gallon each side. Fuel quantity gauges are calibrated to indicate usable fuel.

7.19 ELECTRICAL SYSTEM

The standard electrical power system (refer to Figure 7-13) is 28 V.D.C., negative ground, single main bus, with a 15.5 amp/hr. lead acid battery located in the lower left area of the forward baggage compartment beneath the floor. The manifold type battery is vented with an acid recovery system provided. The standard electrical system uses a single 60 amp self-exciting alternator with solid state alternator control unit (A.C.U.). The maximum continuous output of a single alternator system is 60 amps.

The optional dual system (refer to Figure 7-15) is also 28 V.D.C., negative ground, and is available for use either as a dual or a single alternator system with complete backup. This optional dual alternator system becomes mandatory on those aircraft equipped for flight into known icing conditions or air conditioning.

NOTE

The second alternator of the dual system is a non-self-exciting alternator which requires battery voltage for proper operation and stabilization. Total dual alternator system capacity is 120 amps.

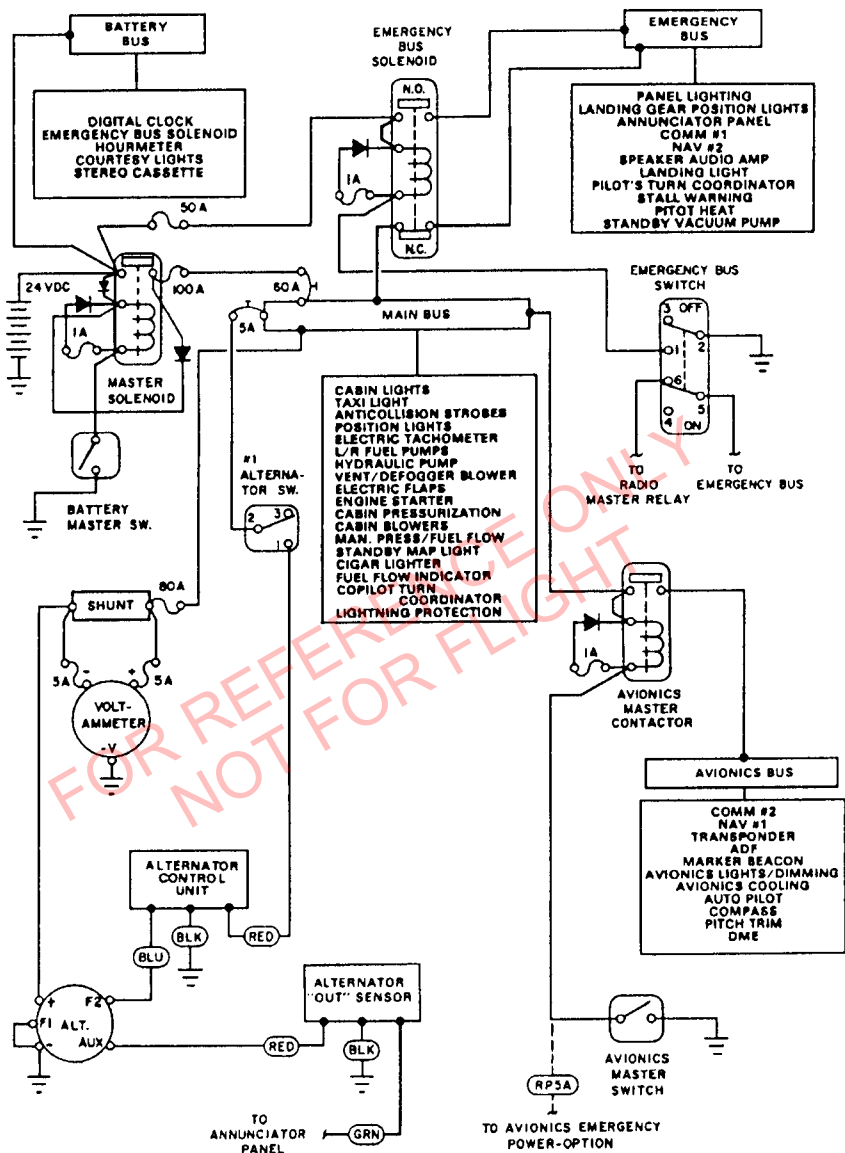

ELECTRICAL DISTRIBUTION SYSTEM (TYPICAL)
SINGLE ALTERNATOR - STANDARD SYSTEM

Figure 7-13

THIS PAGE INTENTIONALLY LEFT BLANK

FOR REFERENCE ONLY
NOT FOR FLIGHT

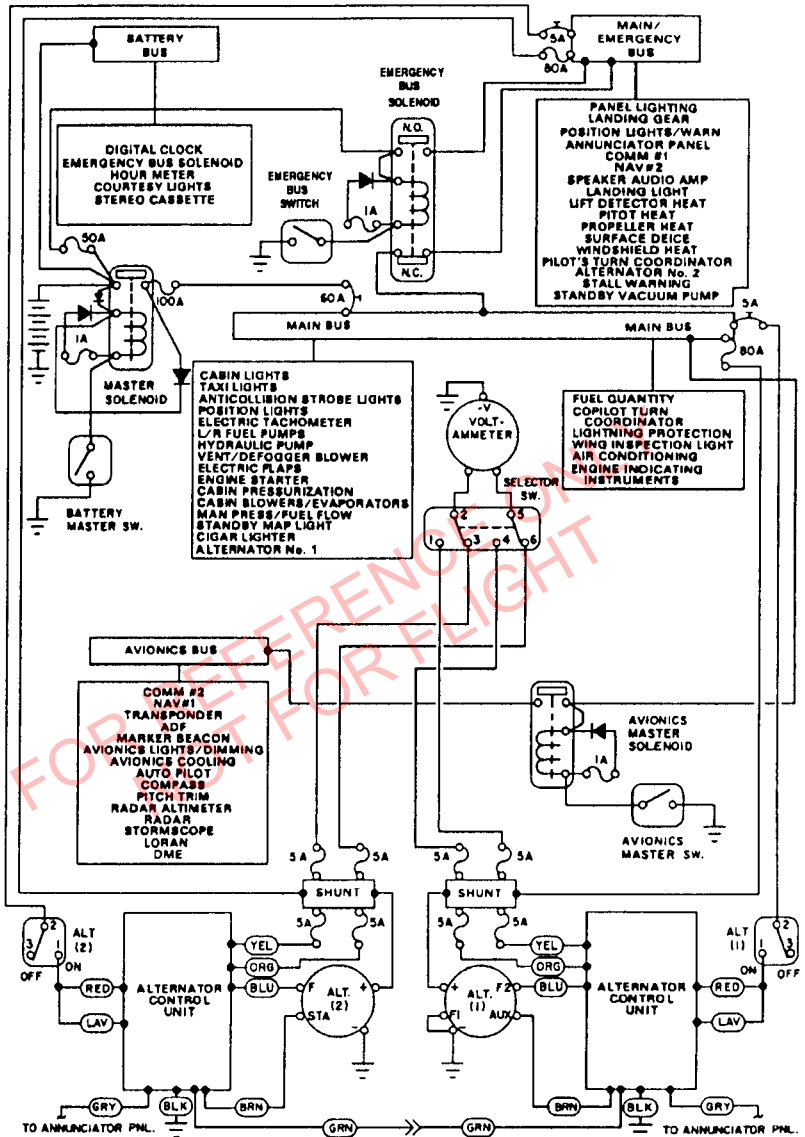

**ELECTRICAL POWER DISTRIBUTION SYSTEM (TYPICAL)
DUAL ALTERNATOR - OPTIONAL**

Figure 7-15

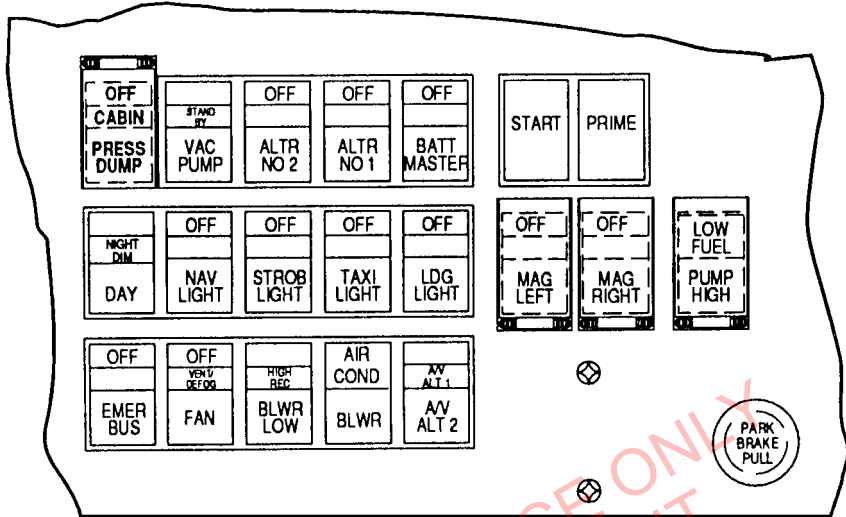

ELECTRICAL SWITCH PANEL

Figure 7-17

In both the single and dual systems, an emergency bus is provided. This bus is controlled by a double acting emergency bus solenoid and by an emergency bus switch. A combination volt/ammeter is provided in both systems, presenting system voltage and/or alternator output current. The standard electrical power system is powered by a 28 V.D.C. negative ground, Teledyne Critten - 60 amp alternator. The optional electrical power system adds a Ford 60 amp alternator providing alternator paralleling.

The standard single alternator feeds its positive output to the single main power distribution bus via the shunt resistor and the 80 amp main bus current limiter. The shunt resistor taps feed the ammeter, therefore ammeter indications represent total system current flow.

The optional electrical power system feeds its positive output to the main power distribution bus via separate shunt resistors and 80 amp main bus current limiters. These shunt resistors feed a single volt/amp meter through a switching circuit, therefore meter readings represent the output from each alternator.

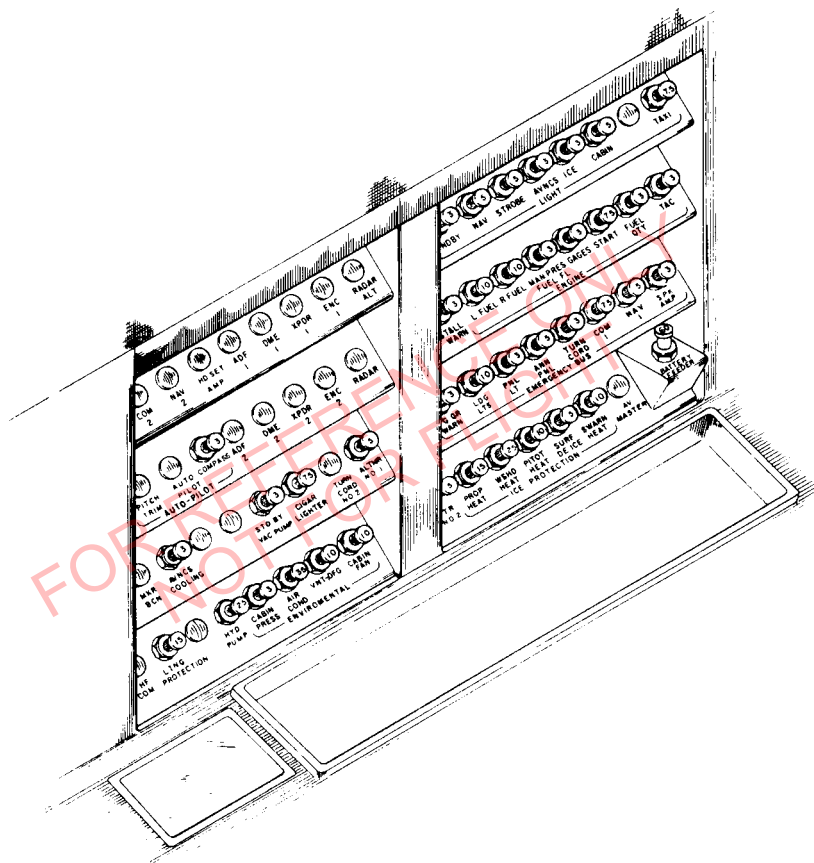

TYPICAL C/B PANEL

Figure 7-19

Voltage regulation is provided by a solid state alternator control unit (A.C.U.). The A.C.U. monitors, and automatically regulates, alternator field current. Should an overvoltage condition occur, the A.C.U. shuts off field winding voltage; thus, an overvoltage relay is not required. The alternator output can be manually shut off by the alternator ON-OFF switch, which also interrupts field winding voltage.

The optional system also feeds the main bus. Each alternator system has its own A.C.U. and alternator ON-OFF switch. The Ford alternator No. 2 is a paralleling alternator. In the dual alternator system, the volt/ammeter is switchable between either alternator.

A separate avionics bus is provided in both system configurations. This avionics bus is powered through a main bus tie or through an optional avionics master switch.

7.21 INSTRUMENT PANEL

The instrument panel is designed to accommodate the customary advanced flight instruments and the normally required power plant instruments. The artificial horizon is vacuum operated and located in the center of the left instrument panel. The vacuum gauge is located on the left side of the pilot's instrument panel. The directional gyro, located in the center of the left instrument panel and the turn and bank indicator, on the left side, are electrically operated.

The heat, defrost, pressurization controls, and pressurization triple indicator are located on the pilot's left instrument panel. The instrument for monitoring the pressurization system is a three-in-one gauge, providing information on cabin rate of climb, cabin altitude, and cabin differential pressure.

The radios are located in the center section of the panel, and the circuit breakers are on the left side panel. An optional radio master switch is located on the top of the center instrument panel. It controls the power to all radios through the radio master contactor. An emergency bus switch, also provides auxiliary power to the Comm #1, speaker amplifier, Nav #2, landing gear warning, turn and bank, panel lights, stall warning and landing light. The emergency bus switch is located on the pilot's bottom left switch panel.

An annunciator panel consisting of a group of warning lights is located across the upper left instrument panel. Monitored functions include: GEAR WARNING, DOOR AJAR, OIL PRESSURE, VACUUM LOW, FUEL PUMP HIGH, SURFACE DEICE, CABIN ALTITUDE, STARTER ENGAGE, ALTERNATOR, FLAPS, OXYGEN, and HYD PUMP.

A ground clearance energy saver system is available to provide direct power to Comm #1 and speaker amplifier without turning on the battery switch. The ground clearance switch is located on the top center instrument panel. When the switch is engaged, direct aircraft battery power is applied to Comm #1 and audio amplifier (speaker). The switch must be turned OFF or depletion of the battery could result.

The manifold pressure line has a drain valve located on the left side of the center console, below and forward of the instrument panel, normally above the pilot's right knee. This allows any moisture which may have collected from condensation to be pulled into the engine. This is accomplished by depressing the valve for 5 seconds while operating the engine at 1000 RPM.

NOTE

Do not depress the valve when manifold pressure exceeds 25 inches Hg.

The column of gauges on the right side of the pilot's panel are engine related instruments. From top to bottom they are turbine inlet temperature (T.I.T.), combination manifold pressure/fuel flow, tachometer (RPM), and combination oil pressure, oil temperature, cylinder head temperature (C.H.T.). The normal operating range for ground and flight operation is indicated on the instruments by a green arc. Yellow arcs indicate either a takeoff or precautionary range. Red radial lines identify the established maximum or minimum limits. When an instrument needle point touches the edge of the red radial nearest the yellow or green arc, the limit is met.

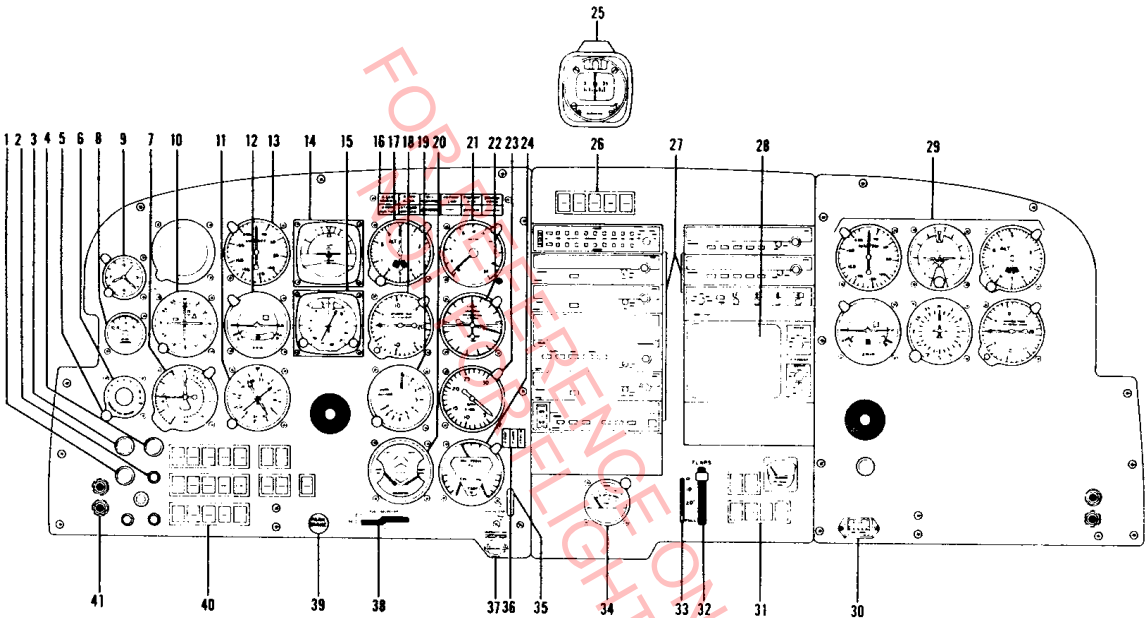

INSTRUMENT PANEL

Figure 7-21

1. CABIN PRESSURE CONTROL
2. DIMMER CONTROL
3. CABIN TEMP. CONTROL
4. DEFROST CONTROL
5. CABIN RATE CHANGE
6. CABIN PRESSURE CONTROLLER
7. TRIPLE INDICATOR
 - (a) CABIN RATE OF CLIMB
 - (b) CABIN ALTITUDE
 - (c) DIFFERENTIAL PRESSURE
8. GYRO SUCTION
9. CLOCK
10. VOR INDICATOR
11. ADF/RMI
12. TURN AND BANK
13. PILOT'S AIRSPEED
14. ATTITUDE INDICATOR
15. HSI
16. ANNUNCIATOR PANEL
17. ALTIMETER
18. VERTICAL SPEED INDICATOR
19. RADAR ALTIMETER
20. FUEL GAUGE
21. T.I.T. GAUGE
22. MANIFOLD PRESSURE/FUEL FLOW
23. RPM
24. OIL PRESSURE/OIL TEMP./CYLINDER HEAD TEMP.
25. COMPASS
26. AVIONICS SWITCHES
27. AVIONICS INSTALLATION
28. RADAR
29. COPILOT'S INSTRUMENTS
30. HOBBS METER
31. DEICE PANEL
32. FLAP SELECTOR
33. FLAP INDICATOR
34. VOLT/AMMETER
35. GEAR HANDLE
36. GEAR INDICATOR LIGHTS
37. EMERGENCY GEAR EXTENSION
38. FUEL SELECTOR
39. PARKING BRAKE
40. ELECTRICAL SWITCH PANEL
41. PHONE/MIKE JACK

INSTRUMENT PANEL (cont)

Figure 7-21 (cont)

7.23 PITOT STATIC SYSTEM

Pitot pressure for the airspeed indicator is sensed by a heated pitot head installed on the bottom of the left wing and is carried through lines within the wing and fuselage to the gauge on the instrument panel (refer to Figure 7-23). Static pressure for the altimeter, vertical speed and airspeed indicators is sensed by two static source pads, one on each side of the rear fuselage forward of the elevator. They connect to a single line leading to the instruments. The dual pickups balance out differences in static pressure caused by slight side slips or skids. Static pressure for the pressurization system outflow valve is sensed by a separate static pad located on the aft bottom of the aircraft in close proximity to the alternate static pad.

An alternate static source control valve is located below the instrument panel to the left of the pilot. For normal operation, the lever remains down. To select alternate static source, place the lever in the up position. When the alternate static source is selected the airspeed and altimeter and vertical speed indicator are vented to the alternate static pad on the bottom aft fuselage. During alternate static source operation, these instruments may give slightly different readings. The pilot can determine the effects of the alternate static source on instrument readings by switching from standard to alternate sources at different airspeeds.

If one or more of the pitot static instruments malfunction, the system should be checked for dirt, leaks or moisture. The static lines may be drained by a valve located on the side panel next to the pilot's seat. The pitot system drains through the pitot mast.

WARNING

Do not attempt to drain static system during pressurized flight.

The holes in the sensors for pitot and static pressure must be fully open and free from blockage. Blocked sensor holes will give erratic or zero readings on the instruments.

The heated pitot head, which alleviates problems with icing and heavy rain, is standard equipment and the switch for pitot heat is located on the lower center instrument panel. Static source pads have been demonstrated to be non-icing; however, in the event icing does occur, selecting the alternate static source will alleviate the problem.

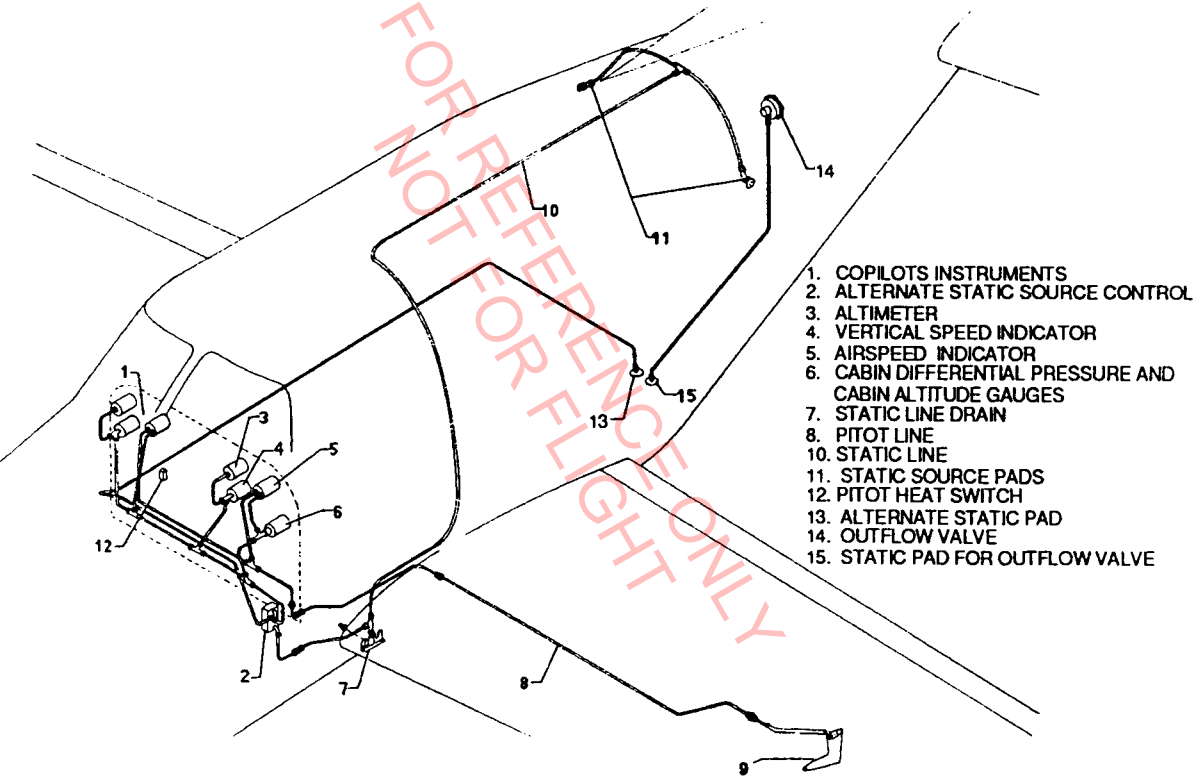

PITOT STATIC SYSTEM

Figure 7-23

7.25 ENVIRONMENTAL SYSTEM

The environmental system consists of an engine bleed air and conditioning system, cabin air distribution system, pressurization and control system, ventilating air system and optional air conditioning system.

The engine bleed air system provides the air supply for pressurizing the cabin. Temperature of the bleed air is controlled using an air-to-air heat exchanger which utilizes ambient air to cool the bleed air, hot air from an exhaust shroud to heat the bleed air, or a mixture of ambient and hot air to obtain the bleed air temperature necessary to maintain the desired cabin comfort level.

The cabin air distribution system consists of left and right side panel ducting, windshield defrost, and ventilation blowers. The side panel ducts provide for overall air distribution throughout the length of the cabin as well as individual controllable air outlets at each seat (eyeball outlets). The defrost control will allow part of the bleed air to be diverted to the windshield defrost outlet. The ventilation blowers supply airflow to the portion of the side wall ducts containing the individual seat outlets (eyeballs).

The cabin pressurization and control system consist of an outflow valve (isobaric), safety valve, cabin altitude and rate selector, electrically operated vacuum solenoid valve, surge tank and associated interconnecting plumbing and wiring. Cabin altitude, differential pressure, and rate of change are displayed on a single 3-inch diameter indicator. Pilot warning (displayed on the annunciator panel) is provided to indicate a cabin altitude above 10,000 feet.

Cabin ventilating air for ground and unpressurized flight operation is supplied from the ambient air source to the bleed air heat exchanger through a ram air selector valve and check valve. A vane-axial blower is provided in the left duct below the forward baggage floor. This will supplement air flow primarily in ground operation. This air source is capable of being heated by mixing with hot air from the exhaust shroud.

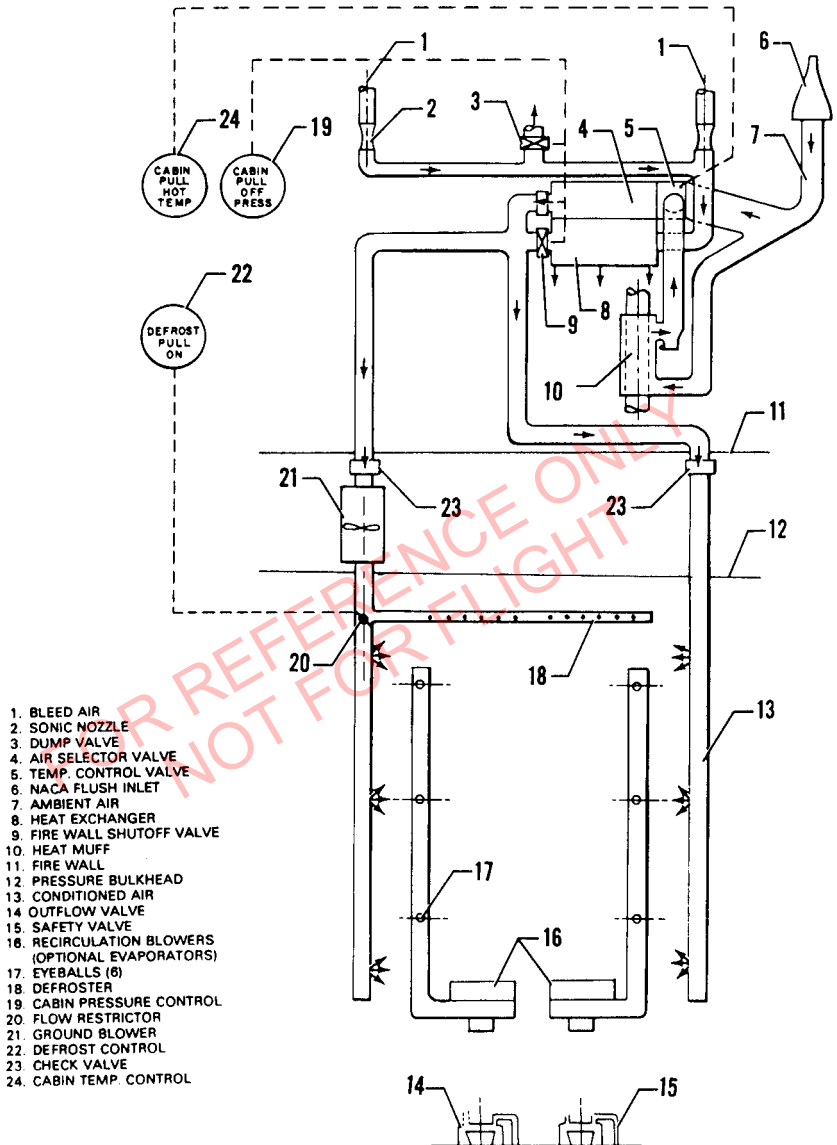

ENVIRONMENTAL SYSTEM

Figure 7-25

NOTE

During extreme cold weather conditions, maximum cabin heat for ground operation and low altitude flight will be obtained when operating with the CABIN PRESS control full out.

7.27 BLEED AIR, CONDITIONING & PRESSURIZATION SYSTEM

Air for cabin pressure is obtained from the engine turbocharger induction air system through two sonic venturi tubes. Bleed air is routed through the bleed air heat exchanger for the temperature conditioning to provide the desired cabin comfort level. Ram air (ambient) is routed across the heat exchanger to cool the bleed air, and hot ambient air from the heat muff is routed across the heat exchanger to heat the bleed air. Mixtures of ambient and hot ambient may also be selected.

Cabin air is controlled by the CABIN PRESS control located on the lower left side of the pilot's instrument panel. Bleed air for cabin air is provided when the control is fully in. Ambient ventilating air is provided when the control is fully out. This control operates three valves: the fire wall shut off valve, the bleed air dump valve, and the ram air selector valve. When fully in, the fire wall shut off valve is open, the bleed air dump valve is closed and the ram air selector valve is positioned to route ambient air across the bleed air heat exchanger. When the control is fully out (pull), the fire wall shut off valve is closed, the bleed air dump valve is open and the ram air selector valve is positioned to route ambient air into the conditioned air ducts through the check valve and into the cabin.

Controls needed to operate the cabin pressurization system are located on the lower left side of the pilot's instrument panel. They include the CABIN PRESS and CABIN TEMP controls, cabin pressure and rate controller, and CABIN DUMP switch.

For pressurized flight, set the cabin pressure controller at 1000 feet above the airport pressure altitude, CABIN PRESS control full in and the CABIN DUMP switch OFF. The rate of cabin change (ascent and descent) is controlled with the rate knob (left lower corner of the cabin pressure controller) and may be adjusted between approximately 200 and 2000 feet per minute, as desired. Setting the rate knob arrow to the 9 o'clock position provides a cabin rate of change of approximately 500 feet per minute. This position gives a comfortable rate for normal operations.

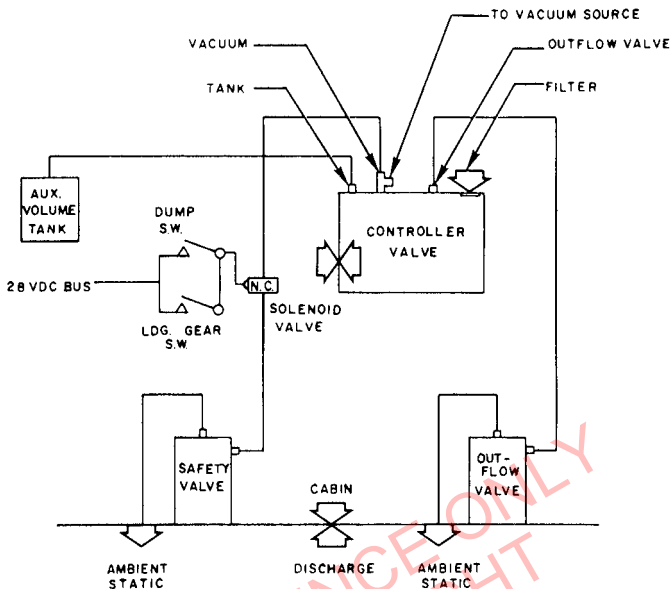

PRESSURIZATION CONTROL SCHEMATIC

Figure 7-27

Next to the cabin pressure controller, a triple indicator simplifies monitoring the system's operation. The triple indicator displays the cabin altitude, cabin rate of change and the differential pressure between the cabin and the outside atmosphere. Maximum cabin differential pressure is 5.5 psi.

A CABIN ALTITUDE warning light on the annunciator display warns the pilot when the cabin altitude is above 10,000 feet. Cabin pressure is automatically regulated to a maximum of 5.5 psi pressure differential. Should the cabin outflow valve malfunction, the cabin safety valve will maintain a maximum of 5.6 cabin differential pressure. The landing gear squat switch, on the left main landing gear, prevents the cabin from being pressurized while the airplane is on the ground.

For complete instructions on the operation of the cabin pressurization system, refer to Section 4 - Normal Procedures.

The CABIN DUMP switch electrically opens a solenoid valve allowing vacuum suction pressure to open the safety valve and rapidly dump cabin pressure to ambient pressure.

CABIN ALTITUDE VS. AIRPLANE ALTITUDE

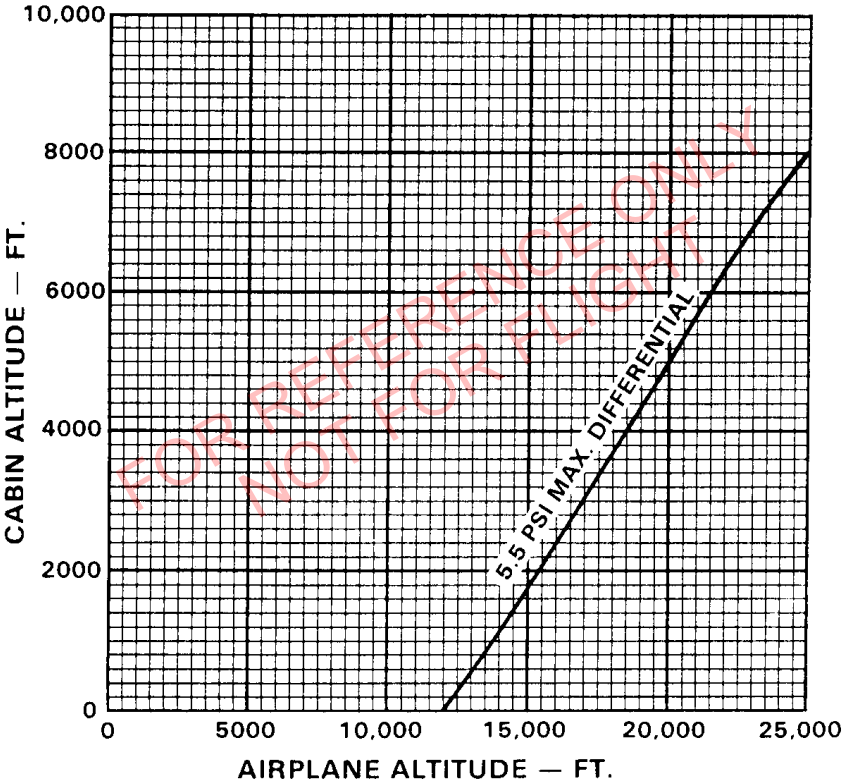

CABIN ALTITUDE VS. AIRPLANE ALTITUDE

Figure 7-29

For unpressurized flight the CABIN PRESS control should be pulled fully out. Activating the cabin dump switch will provide maximum airflow through the cabin. Cabin temperature will continue to be controlled by the CABIN TEMP control.

For complete instructions on pressurization malfunctions, refer to Section 3 - Emergency Procedures.

7.29 VACUUM SYSTEM (STANDARD)

The standard vacuum system consists of an engine driven dry air vacuum pump, regulator, vacuum gauge, inlet filter and plumbing connecting the autopilot, attitude indicator, cabin pressure controller and vacuum solenoid valve. The latter two components are part of the cabin pressurization control system.

The vacuum gauge, mounted on the left side of the pilot's instrument panel (refer to Figure 7-21), provides information to the pilot regarding the operation of the vacuum system. A decrease in vacuum in a system that has remained constant over an extended period, may indicate a dirty filter, dirty screens, possibly a sticking vacuum regulator, or a leak in the system. Zero gauge reading indicates either a sheared pump drive, defect in pump, possibly a defective gauge, or a collapsed line. In the event of any gauge variation from the norm, the pilot should have a mechanic check the system to prevent possible damage to the system components or eventual failure of the system.

The vacuum regulator, mounted on the forward pressure bulkhead inside the cabin, controls the system vacuum between 4.8 and 5.2 inches of mercury (as shown on the vacuum gauge).

During unpressurized cabin flight mode, the vacuum pump supplies vacuum to the system.

During pressurized cabin flight mode, the vacuum pump supplies vacuum to the system until the cabin pressure differential increases to approximately 2.3 PSID. Above this, cabin pressure unloads the vacuum pump and supplies sufficient airflow to operate the gyros (4.0 inches of vacuum). Under these operating conditions, should a vacuum pump failure occur, no decrease in the vacuum gauge will be observed. Should the vacuum gauge fall below 4.0 inches of mercury, a system failure must be considered.

(OPTIONAL VACUUM SYSTEM WITH STAND-BY PUMP)

The optional vacuum system adds a second clutch-driven dry air vacuum pump, a second regulator and a vacuum manifold/check valve.

The vacuum gauge provides the same information to the pilot regarding operation of the vacuum system as the standard system and additionally incorporates two red flow buttons which indicate when the respective vacuum pump is operating. The left flow button indicates the primary pump and the right flow button indicates the standby pump. If the flow button is visible the pump is not operating.

The system incorporates two vacuum regulators mounted on the forward pressure bulkhead in the forward baggage compartment and a vacuum manifold/check valve mounted on the forward pressure bulkhead inside the cabin. The vacuum in the system is regulated between 4.8 and 5.2 inches of mercury (as shown on the vacuum gauge).

The standby vacuum pump is operated by the STANDBY VAC PUMP switch located on the main switch panel on the left side of the pilot's instrument panel. For normal operations the standby pump is OFF and the right side red flow button will be visible on the vacuum gauge. Should the left side red flow button appear the STANDBY VAC PUMP switch should be turned ON. The vacuum gauge reading will return to normal and the right side red flow button will disappear. The standby vacuum pump has the same capacity as the primary pump and all vacuum systems will function normally. If a primary pump failure has occurred, the problem should be corrected prior to any further flights.

Cabin pressurization will not provide a back up vacuum supply in aircraft equipped with the optional system.

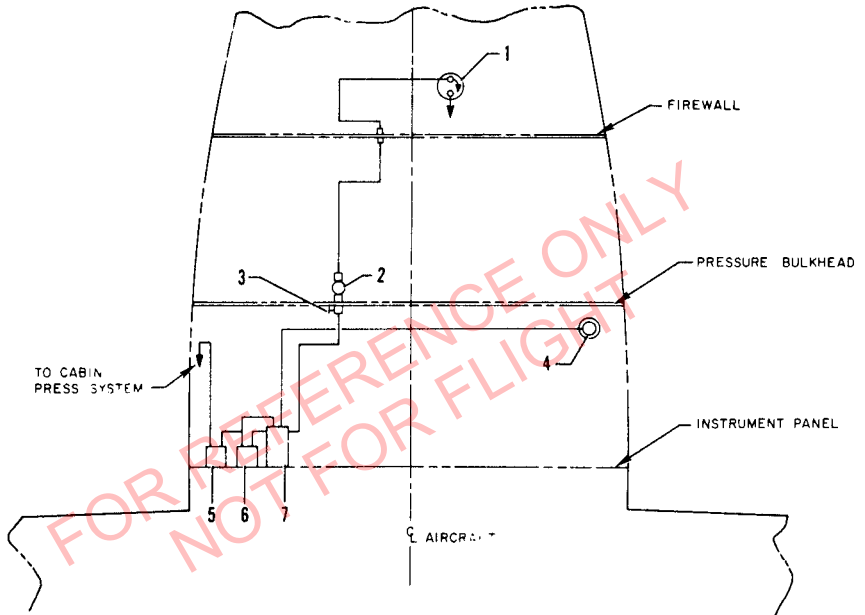

1. VACUUM PUMP
2. VACUUM REGULATOR
3. VACUUM PRESSURE SWITCH
4. INLINE FILTER
5. CABIN PRESSURE GAUGE
6. VACUUM GAUGE
7. PILOT'S ATTITUDE GYRO

VACUUM SYSTEM (STANDARD)

Figure 7-31

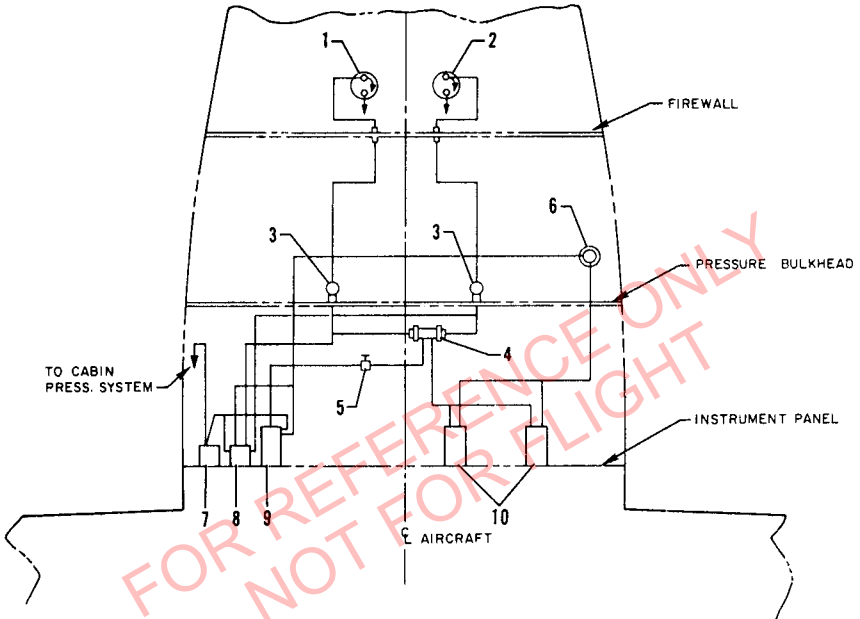

1. VACUUM PUMP (CONTINUOUS)
2. CLUTCH DRIVEN STAND-BY PUMP
3. VACUUM REGULATOR
4. VACUUM MANIFOLD/CHECK VALVE
5. VACUUM PRESSURE SWITCH
6. INLINE FILTER
7. CABIN PRESSURE CONTROLLER
8. VACUUM GAUGE
9. PILOT'S ATTITUDE GYRO
10. COPILOT'S AIR DRIVEN GYROS

VACUUM SYSTEM (WITH STAND-BY PUMP)

Figure 7-33

7.31 CABIN FEATURES

The front seats are adjustable fore and aft and vertically. Pivoting armrests are provided on the inboard side of each seat.

Shoulder harnesses with inertia reels are standard equipment for all seats. On early models shoulder harnesses were not installed on aft facing seats.* The inertia reel should be checked by tugging sharply on the strap. The reel will lock in place under this test and prevent the strap from extending. Under normal movement the strap will extend and retract as required.

The shoulder harness is routed over the shoulder adjacent to the windows and attached to the lap belt buckle.

Shoulder harnesses shall be worn during takeoff, landing and during an emergency situation.

Standard cabin features include a pilot's storm window, ash trays, map pockets, cup holders, a cigar lighter, sun visors, stowage drawers under the aft facing seats and a baggage restraint net behind the rear seats.

Two combination instrument panel flood/map lights are provided forward, and four passenger reading lights are provided aft. A cabin entrance flood light is located above the door.

The four passenger seats with folding armrests and headrests are positioned in a club seating arrangement. The center seats face aft. The seat backs recline by pushing a button mounted in the outboard armrest.

An optional conference table located between the right passenger seats is available. The table is extended by pulling in on the upper edge of the leaf and then upward. The leaf is then rotated down into position and unfolded. Reverse this procedure for stowage.

Optional cabinets located behind the pilot seats are available. The right cabinet is designed for Jeppesen manual stowage in the bottom and contains a drawer for general use.

The left cabinet contains a removable ice chest, a tray, space for six canned drinks, and a fold down cup holder in the lower drawer. The upper drawer has space for thermos containers, cups and miscellaneous items.

*On aircraft serial numbers 4608008 through 4608044, aft facing seats are equipped with lap belts only.

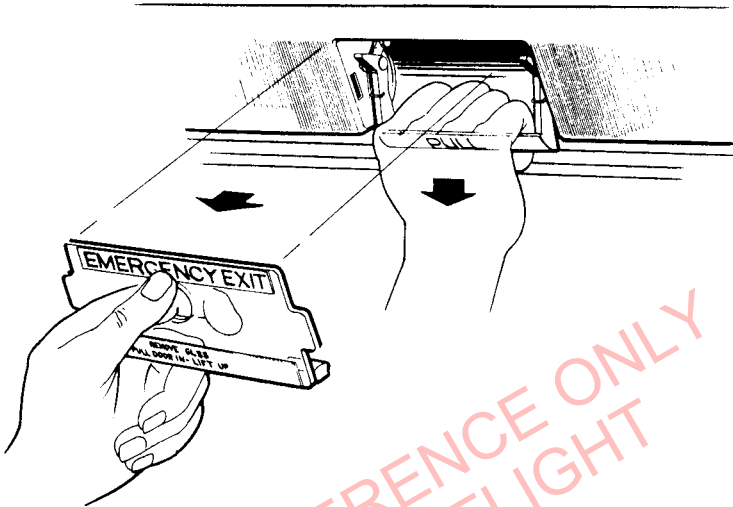

EMERGENCY EXIT

Figure 7-35

Optional passenger oxygen generators and masks are available and, if installed, are located in a drawer under the right aft facing seat.

Crew oxygen is located under the copilot's seat, readily available to either crew member. An annunciator light illuminates when any of the three generators have been activated. The light remains illuminated with the battery switch ON, until the system is serviced.

An optional fire extinguisher is available and, if installed, is located either behind the spar or on top of the right cabinet.

The emergency exit is located on the right side of the fuselage, adjacent to the aft facing seat. Instructions for opening the emergency exit are placarded on the cover over the handle. To open, remove the cover and pull the handle. The window releases inward. The cabin must be unpressurized to open the exit.

7.33 BAGGAGE AREA

The airplane has two separate baggage areas each with a 100-pound capacity. A 14-cubic-foot forward baggage compartment, located just aft of the fire wall, is accessible through a 19 x 23 inch door on the left side of the fuselage. An aft baggage compartment, which is accessible from inside the cabin, is located behind the back seats.

A forward baggage door annunciation system senses the baggage door latch position. If the baggage door is not closed and latched, the DOOR AJAR annunciator light will illuminate on the annunciator panel.

NOTE

It is the pilot's responsibility to be sure when the baggage is loaded that the airplane's C.G. falls within the allowable C.G. range (refer to Section 6, Weight and Balance).

7.35 FINISH

All exterior surfaces are primed and finished with polyurethane. To keep the finish attractive looking, polyurethane touch-up paint is available from Piper Dealers.

7.37 STALL WARNING

An approaching stall is indicated by a stall warning horn which is activated between five and ten knots above stall speed. Mild airframe buffeting may also precede the stall. Stall speeds are shown on a graph in the Performance Charts Section. The stall warning indication consists of a continuous sounding horn located behind the instrument panel. The landing gear warning horn has a different sound from that of the stall warning horn. The landing gear warning horn has a 90 cycles per minute beeping sound. The stall warning horn is activated by a lift detector on the leading edge of the left wing.

7.39 EMERGENCY LOCATOR TRANSMITTER*

The Emergency Locator Transmitter (ELT) meets the requirements of FAR 91.52. It operates on self-contained batteries and is located in the aft fuselage section. It is accessible through a cover on the bottom right side.

A battery replacement date is marked on the transmitter. To comply with FAA regulations, the battery must be replaced on or before this date. The battery must also be replaced if the transmitter has been used in an emergency situation, if the accumulated test time exceeds one hour, or if the unit has been inadvertently activated for an undetermined time period.

NOTE

If for any reason a test transmission is necessary, the test transmission should be conducted only in the first five minutes of any hour and limited to three audio sweeps. If a test must be made at any other time, the test should be coordinated with the nearest FAA tower or flight service station.

NARCO ELT 10 OPERATION

On the ELT unit itself is a three position switch placarded ON, OFF and ARM. The ARM position sets the ELT so that it will transmit after impact and will continue to transmit until its battery is drained. The ARM position is selected when the ELT is installed in the airplane and it should remain in that position.

To use the ELT as a portable unit in an emergency, remove the cover and unlatch the unit from its mounting base. The antenna cable is disconnected by a left quarter-turn of the knurled nut and a pull. A sharp tug on the two small wires will break them loose. Deploy the self-contained antenna by pulling the plastic tab marked PULL FULLY TO EXTEND ANTENNA. Move the switch to ON to activate the transmitter.

In the event the transmitter is activated by an impact, it can only be turned off by moving the switch on the ELT unit to OFF. Normal operation can then be restored by pressing the small clear plastic reset button located on the top of the front face of the ELT and then moving the switch to ARM.

*Optional equipment

A pilot's remote switch located on the top center instrument panel is provided to allow the transmitter to be turned on from inside the cabin. The pilot's remote switch is a three-position covered switch (ON, ARMED, and OFF). The switch is normally in the center, ARMED position, with the cover closed. Lifting the cover and moving the switch to the ON position will activate the transmitter. Closing the cover repositions the switch to the ARMED position. This will deactivate the ELT only if the impact switch was not activated.

The ELT should be checked to make certain the unit has not been activated during the ground check. Check by selecting 121.50 MHZ on an operating receiver. If there is an oscillating chirping sound, the ELT may have been activated and should be turned off immediately. This requires removal of the access cover and moving the switch to OFF, then press the reset button and return the switch to ARM. Recheck with the receiver to ascertain the transmitter is silent.

7.41 EXTERNAL POWER*

An optional external power receptacle allows the airplane engine to be started from an external battery without the necessity of gaining access to the airplane battery. The cable from the external battery can be attached to a receptacle, located on the aft side of the forward baggage compartment. Instructions on a placard located on the cover of the receptacle should be followed when starting with external power. For instructions on the use of external power, refer to Starting Engines - Section 4.

7.43 RADAR*

A weather radar system can be installed in this airplane. The basic components of this installation are a Receiver-Transmitter Antenna and a cockpit indicator. The function of the weather radar system is to detect weather conditions along the flight path and to visually display a continuous weather outline on the cockpit indicator. Through interpretation of the advance warning given on the display, the pilot can make an early decision on the most desirable weather avoidance course.

*Optional equipment

NOTE

When operating weather avoidance radar systems inside of moderate to heavy precipitation, it is advisable to set the range scale of the radar to its lowest scale.

For detailed information on the weather radar system and for procedures to follow in operating and adjusting the system to its optimum efficiency, refer to Section 9, Supplements, or the appropriate operating and service manuals provided by the radar system manufacturer.

WARNING

Heating and radiation effects of radar can cause serious damage to the eyes and tender organs of the body. Personnel should not be allowed within fifteen feet of the area being scanned by the antenna while the system is transmitting. Do not operate the radar during refueling or in the vicinity of trucks or containers accommodating explosives or flammables. Flashbulbs can be exploded by radar energy. Before operating the radar, direct the nose of the airplane so that the forward 120 degree sector is free of any metal objects such as other aircraft or hangars for a distance of at least 100 yards, and tilt the antenna upward 12 degrees. Do not operate the radar while the airplane is in a hangar or other enclosure.

TABLE OF CONTENTS

SECTION 8

AIRPLANE HANDLING, SERVICING AND MAINTENANCE

Paragraph No.		Page No.
8.1	General	8-1
8.3	Airplane Inspection Periods	8-2
8.5	Preventive Maintenance	8-3
8.7	Airplane Alterations	8-3
8.9	Ground Handling.....	8-4
8.11	Engine Induction Air Filter	8-7
8.13	Brake Service	8-7
8.15	Hydraulic System Service.....	8-9
8.17	Landing Gear Service.....	8-9
8.19	Propeller Service	8-10
8.21	Oil Requirements.....	8-11
8.23	Fuel System	8-12
8.25	Tire Inflation.....	8-16
8.27	Battery Service	8-16
8.29	Emergency Oxygen System (Optional).....	8-16
8.31	Pressurization System	8-16
8.33	Lubrication	8-17
8.35	Cleaning	8-17
8.36	Cleaning and Maintenance of Relief Tube System	8-22

SECTION 8

AIRPLANE HANDLING, SERVICING, AND MAINTENANCE

8.1 GENERAL

This section provides guidelines relating to the handling, servicing, and maintenance of the Malibu. For complete maintenance instructions, refer to the PA-46 Maintenance Manual.

WARNING

Inspection, maintenance and parts requirements for all non-PIPER approved STC installations are not included in this handbook. When a non-PIPER approved STC installation is incorporated on the airplane, those portions of the airplane affected by the installation must be inspected in accordance with the inspection program published by the owner of the STC. Since non-PIPER approved STC installations may change systems interface, operating characteristics and component loads or stresses on adjacent structures, PIPER provided inspection criteria may not be valid for airplanes with non-PIPER approved STC installations.

WARNING

Modifications must be approved in writing by PIPER prior to installation. Any and all other installations, whatsoever, of any kind will void this warranty in it's entirety.

8.1 GENERAL (CONTINUED)

WARNING

Use only genuine PIPER parts or PIPER approved parts obtained from PIPER approved sources, in connection with the maintenance and repair of PIPER airplanes.

Genuine PIPER parts are produced and inspected under rigorous procedures to insure airworthiness and suitability for use in PIPER airplane applications. Parts purchased from sources other than PIPER, even though identical in appearance, may not have had the required tests and inspections performed, may be different in fabrication techniques and materials, and may be dangerous when installed in an airplane.

Additionally, reworked or salvaged parts or those parts obtained from non-PIPER approved sources, may have service histories which are unknown or cannot be authenticated, may have been subjected to unacceptable stresses or temperatures or may have other hidden damage not discernible through routine visual or nondestructive testing. This may render the part, component or structural assembly, even though originally manufactured by PIPER, unsuitable and unsafe for airplane use.

PIPER expressly disclaims any responsibility for malfunctions, failures, damage or injury caused by use of non-PIPER approved parts.

8.1 GENERAL (CONTINUED)

Every owner should stay in close contact with an authorized Piper Service Center or Piper's Customer Service Department to obtain the latest information pertaining to their airplane, and to avail themselves of Piper Aircraft's support systems.

Piper Aircraft Corporation takes a continuing interest in having owners get the most efficient use from their airplane and keeping it in the best mechanical condition. Consequently, Piper Aircraft, from time to time, issues service releases including Service Bulletins, Service Letters, Service Spares Letters, and others relating to the airplane.

Piper Service Bulletins are of special importance and Piper considers compliance mandatory. These are sent to the latest FAA-registered owners in the United States (U.S.) and Piper Service Centers worldwide. Depending on the nature of the release, material and labor allowances may apply. This information is provided to all authorized Piper Service Centers.

Service Letters deal with product improvements and servicing techniques pertaining to the airplane. They are sent to Piper Service Centers and, if necessary, to the latest FAA-registered owners in the U.S. Owners should give careful attention to Service Letter information.

Service Spares Letters offer improved parts, kits, and optional equipment which were not available originally, and which may be of interest to the owner.

Piper Aircraft Corporation offers a subscription service for Service Bulletins, Service Letters, and Service Spares Letters. This service is available to interested persons such as owners, pilots, and mechanics at a nominal fee, and may be obtained through an authorized Piper Service Center or Piper's Customer Services Department.

Maintenance manuals, parts catalogs, and revisions to both, are available from Piper Service Centers or Piper's Customer Services Department.

Any correspondence regarding the airplane should include the airplane model and serial number to ensure proper response.

8.3 AIRPLANE INSPECTION PERIODS

WARNING

All inspection intervals, replacement time limits, overhaul time limits, the method of inspection, life limits, cycle limits, etc., recommended by PIPER are solely based on the use of new, remanufactured or overhauled PIPER approved parts. If parts are designed, manufactured, remanufactured, overhauled and/or approved by entities other than PIPER, then the data in PIPER'S maintenance/service manuals and parts catalogs are no longer applicable and the purchaser is warned not to rely on such data for non-PIPER parts. All inspection intervals, replacement time limits, overhaul time limits, the method of inspection, life limits, cycle limits, etc., for such non-PIPER parts must be obtained from the manufacturer and/or seller of such non-PIPER parts.

Piper Aircraft Corporation has developed inspection items and required inspection intervals (i.e. 50, 100, 500, and 1000 hours) for the specific model aircraft. Appropriate forms are contained in the applicable Piper Service/Maintenance Manual, and should be complied with by a properly trained, knowledgeable, and qualified mechanic at a Piper authorized Service Center or a reputable repair shop. Piper Aircraft Corporation cannot accept responsibility for the continued airworthiness of any aircraft not maintained to these standards, and/or not brought into compliance with applicable Service Bulletins issued by Piper Aircraft Corporation, instructions issued by the engine, propeller, or accessory manufacturers, or Airworthiness Directives issued by the FAA.

A programmed Inspection, approved by the Federal Aviation Administration (FAA), is also available to the owner. This involves routine and detailed inspections to allow maximum utilization of the airplane. Maintenance inspection costs are reduced, and the maximum standard of continued airworthiness is maintained. Complete details are available from Piper Aircraft Corporation.

In addition, but in conjunction with the above, the FAA requires periodic inspections on all aircraft to keep the Airworthiness Certificate in effect. The owner is responsible for assuring compliance with these inspection requirements and for maintaining proper documentation in logbooks and/or maintenance records.

8.3 AIRPLANE INSPECTION PERIODS (CONTINUED)

A spectrographic analysis of the engine oil is available from several sources. This inspection, performed properly, provides a good check of the internal condition of the engine. To be accurate, induction air filters must be cleaned or changed regularly, and oil samples must be taken and sent in at regular intervals.

8.5 PREVENTIVE MAINTENANCE

The holder of a pilot certificate issued under Federal Aviation Regulations (FAR) Part 61 may perform certain preventive maintenance as defined in the FARs. This maintenance may be performed only on an aircraft which the pilot owns and operates, and which is not used in air carrier or air taxi/commercial operations service.

All other aircraft maintenance must be accomplished by a person or facility appropriately certificated by the Federal Aviation Administration (FAA) to perform that work.

Anytime maintenance is accomplished, an entry must be made in the appropriate aircraft maintenance records. The entry shall include:

- (a) The date the work was accomplished.
- (b) Description of the work.
- (c) Number of hours on the aircraft.
- (d) The certificate number of pilot performing the work.
- (e) Signature of the individual doing the work.

8.7 AIRPLANE ALTERATIONS

If the owner desires to have his aircraft modified, he must obtain FAA approval for the alteration. Major alterations accomplished in accordance with advisory Circular 43.13-2, when performed by an A & P mechanic, may be approved by the local FAA office. Major alterations to the basic airframe or systems not covered by AC 43.13-2 require a Supplemental Type Certificate.

The owner or pilot is required to ascertain that the following Aircraft Papers are in order and in the aircraft.

- (a) To be displayed in the aircraft at all times:
 - (1) Aircraft Airworthiness Certificate Form FAA-8100-2.
 - (2) Aircraft Registration Certificate Form FAA-8050-3.
 - (3) Aircraft Radio Station License if transmitters are installed.

- (b) To be carried in the aircraft at all times:
 - (1) Pilot's Operating Handbook.
 - (2) Weight and Balance data plus a copy of the latest Repair and Alteration Form FAA-337, if applicable.
 - (3) Aircraft equipment list.

Although the aircraft and engine logbooks are not required to be in the aircraft, they should be made available upon request. Logbooks should be complete and up to date. Good records will reduce maintenance cost by giving the mechanic information about what has or has not been accomplished.

8.9 GROUND HANDLING

- (a) Towing

The airplane may be moved on the ground by the use of the nose wheel steering bar that is stowed in the forward baggage compartment or by power equipment that will not damage or excessively strain the nose gear steering assembly.

CAUTIONS

When towing with power equipment, do not turn the nose gear beyond its steering radius in either direction, as this will result in damage to the nose gear and steering mechanism.

Do not tow the airplane when the controls are secured.

In the event towing lines are necessary, ropes should be attached to both main gear struts as high up on the tubes as possible. Lines should be long enough to clear the nose and/or tail

by not less than fifteen feet, and a qualified person should ride in the pilot's seat to maintain control by use of the brakes.

(b) Taxiing

CAUTION

Do not operate engine above 1200 RPM with cabin doors open.

Before attempting to taxi the airplane, ground personnel should be instructed and approved by a qualified person authorized by the owner. Engine starting and shut-down procedures as well as taxi techniques should be covered. When it is ascertained that the propeller back blast and taxi areas are clear, power should be applied to start the taxi roll, and the following checks should be performed:

- (1) Taxi a few feet forward and apply the brakes to determine their effectiveness.
- (2) Taxi with the propeller set in low pitch, high RPM setting.
- (3) While taxiing, make slight turns to ascertain the effectiveness of the steering.
- (4) Observe wing clearance when taxiing near buildings or other stationary objects. If possible, station an observer outside the airplane.
- (5) When taxiing over uneven ground, avoid holes and ruts.
- (6) Do not operate the engine at high RPM when running up or taxiing over ground containing loose stones, gravel, or any loose material that may cause damage to the propeller blades.

(c) Parking

When parking the airplane, be sure that it is sufficiently protected from adverse weather conditions and that it presents no danger to other aircraft. When parking the airplane for any length of time or overnight, it is suggested that it be moored securely.

- (1) To park the airplane, head it into the wind if possible.
- (2) The parking brake knob is located just below the left control column. To set the parking brake, first depress and hold the toe brakes and then pull out on the parking brake knob. To release the parking brake, first depress the brake pedals and then push in on the parking brake knob.

WARNING

No braking will occur if aircraft brakes are applied while parking brake handle is pulled and held.

CAUTION

Care should be taken when setting brakes that are overheated or during cold weather when accumulated moisture may freeze a brake.

- (3) Aileron and elevator controls should be secured with the front seat belt and chocks used to properly block the wheels.

(d) Mooring

The airplane should be moored for immovability, security and protection. The following procedures should be used for the proper mooring of the airplane:

- (1) Head the airplane into the wind if possible.
- (2) Retract the flaps.
- (3) Immobilize the ailerons and elevator by looping the seat belt through the control wheel and pulling it snug.
- (4) Block the wheels.
- (5) Secure tie-down ropes to the main gear assemblies and to the tail ring at approximately 45 degree angles to the ground. When using rope of non-synthetic material, leave sufficient slack to avoid damage to the airplane should the ropes contract.

CAUTION

Use bowline knots, square knots or locked slip knots. Do not use plain slip knots.

NOTE

Additional preparations for high winds include using tie-down ropes from the nose landing gear and securing the rudder.

- (6) Install a pitot head cover if available. Be sure to remove the pitot head cover before flight.
- (7) Cabin and baggage door should be locked when the airplane is unattended.

8.11 ENGINE INDUCTION AIR FILTER

(a) Removing Induction Air Filter

- (1) Remove louvered induction air panel assembly at nose of aircraft by removing screws.
- (2) Remove screws around perimeter of filter on induction air inlet to withdraw inlet and filter.

(b) Cleaning Induction Air Filter

The induction air filter must be cleaned at least once every 50 hours, and more often, even daily, when operating in dusty conditions. Extra filters are inexpensive, and a spare should be kept on hand for use as a rapid replacement.

To clean the filter:

- (1) Tap filter gently to remove dirt particles. Do not use compressed air or cleaning solvents.
- (2) Inspect filter. If paper element is torn or ruptured or gasket is damaged, the filter should be replaced. The usable life of the filter should be restricted to one year or 500 hours, whichever comes first.
- (3) After cleaning check all components for dirt and damage. Wipe the filter and inlet clean. Do not oil the filter.

(c) Installation of Induction Air Filter

Replace filter, inlet and screws. Reinstall induction air panel assembly.

8.13 BRAKE SERVICE

The brake system is filled with MIL-H-5606 (petroleum base) hydraulic fluid. The fluid level should be checked periodically or at every 100 hour inspection and replenished when necessary. The brake fluid reservoir is

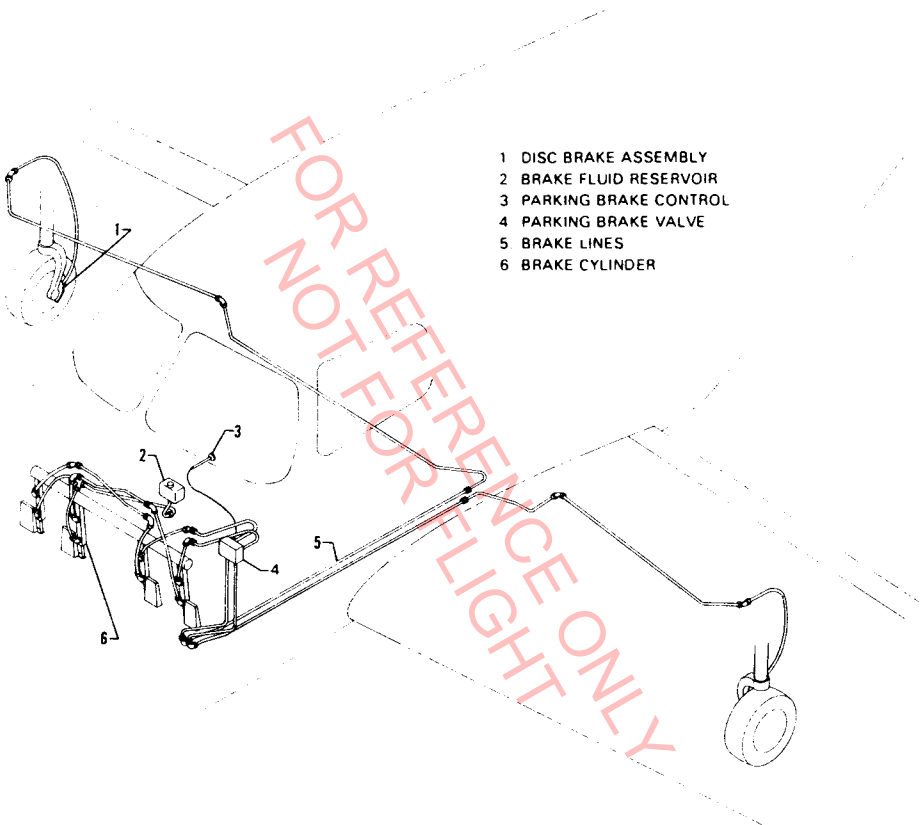

BRAKE SYSTEM
Figure 8-1

located behind the aft access panel in the forward baggage compartment. If the entire system must be refilled, fill with fluid under pressure from the brake end of the system. This will eliminate air from the system.

No adjustment of the brake clearances is necessary. If, after extended service, brake blocks become excessively worn they should be replaced with new segments.

8.15 HYDRAULIC SYSTEM SERVICE

The hydraulic system reservoir is an integral part of the electric hydraulic pump assembly. It is located aft of the aft cabin baggage compartment and is accessible through the baggage compartment aft closeout panel. Fill the reservoir with MIL-H-5606 hydraulic fluid. The fluid level should be checked periodically or every 100 hour inspection and replenished when necessary. With the landing gear down and the system up to pressure, fill to the FULL line on the sight gauge.

8.17 LANDING GEAR SERVICE

The main landing gear uses Cleveland Aircraft Products 6.00 x 6 wheels with 6.00 x 6, eight-ply rating tires and tubes. The nose wheel uses a McCauley or a Cleveland Aircraft Products 5.00 x 5 wheel with a 5.00 x 5 six-ply rating, type III tire and tube. (Refer to paragraph 8.25.)

Wheels are removed by taking off the hub cap, cotter pin, axle nut, and the two bolts holding the brake segment in place. Mark tire and wheel for reinstallation; then dismount by deflating the tire, removing the three through-bolts from the wheel and separating the wheel halves.

Landing gear oleos should be serviced according to the instructions on the units. The main oleos should be extended under normal static load until 2.5 +/- 0.25 inches of oleo piston tube is exposed, and the nose gear should show 1.5 +/- 0.25 inches. To add air to the oleo struts, attach a strut pump to the valve assembly near the top of the oleo strut housing and pump the oleo to the desired position. To add oil, jack the aircraft, release the air pressure in the strut, remove the valve core and add oil through this opening with the strut extended. After the strut is full, compress it slowly and fully to allow excess air and oil to escape. With the strut still compressed reinsert the valve core and pump up the strut as above.

In jacking the aircraft for landing gear or other service, two hydraulic jacks and a tail stand should be used. At least 400 pounds of ballast should be placed on the base of the tail stand before the airplane is jacked up. The hydraulic jacks should be placed under the jack points on the bottom of the wing and the airplane jacked up until the tail skid is at the right height to attach the tail stand. After the tail stand is attached and the ballast added, jacking may be continued until the airplane is at the height desired.

The steering rods from the rudder pedals to the transverse bellcrank in the nose wheel tunnel are factory adjusted and should be readjusted only in accordance with the applicable rigging specification. Nose wheel alignment is accomplished by adjusting the rod end(s) on the steering bungee assembly in such a way that the nose wheel is in line with the fore and aft axis of the plane when the rudder pedals are centered. Alignment of the nose wheel can be checked by pushing the airplane back and forth with the rudder two degrees to the right to determine that the plane follows a straight line. The turning arc of the nose wheel is $30^\circ \pm 1^\circ$ in either direction and is limited by stops at the trunnion forging or the forward steering contact arm mounted on the engine mount.

NOTE

The rudder is set to 2° right with the rudder pedals neutralized and the nose wheel centered.

8.19 PROPELLER SERVICE

The spinner and backing plate should be cleaned and inspected for cracks frequently. Before each flight the propeller should be inspected for nicks, scratches, and corrosion. Significant damage must be repaired by a qualified mechanic prior to flight. Nicks or scratches cause an area of increased stress which can lead to serious cracks or the loss of a propeller tip. The back face of the blades should be painted when necessary with flat black paint to retard glare. To prevent corrosion, the surface should be cleaned and waxed periodically.

8.21 OIL REQUIREMENTS

NOTE

Refer to current Continental Service Bulletin (Recommended Fuel and Oil Grades) for further information.

The oil capacity of the Teledyne Continental engine is 8 quarts with an inflight minimum quantity of approximately 3.5 quarts. Maximum endurance flights should begin with 8 quarts of oil. For all shorter flights, it is recommended that oil be added if the quantity falls to 7 quarts. It is recommended that engine oil be drained and renewed every 100 hours, or sooner under unfavorable conditions. Full flow cartridge type oil filters should be replaced each 50 hours of operation. Teledyne Continental recommends that *only* the larger (approximately 5.8 inch high) full flow oil filter be used on the TSIO520BE engine. The following grades are required for temperatures:

OIL VISCOSITY

	Aviation Grade	SAE #	Multi-Viscosity Grade SAE #
Below 40°F	65	30	15W - 50 20W - 50
Above 40°F	100	50	15W - 50 20W - 50 25W - 60

8.23 FUEL SYSTEM

(a) Servicing Fuel System

At every 100 hour inspection or after an extended downtime, the fuel filter strainer must be cleaned. The fuel filter strainer is located below the floor on the lower right side of the forward baggage compartment.

(b) Fuel Requirements (AVGAS ONLY)

The minimum aviation grade fuel is for the PA-46-310P is 100. Since the use of lower grades can cause serious engine damage in a short period of time, the engine warranty is invalidated by the use of lower octanes.

Whenever 100 or 100LL grade fuel is not available, commercial grade 100/130 should be used. (See Fuel Grade Comparison Chart.) Refer to the latest issue of Continental Service Bulletin (Recommended Fuel and Oil Grades).

A summary of the current grades as well as the previous fuel designation is shown in the following chart:

FUEL GRADE COMPARISON CHART

Previous Commercial Fuel Grades (ASTM-D910)			Current Commercial Fuel Grades (ASTM-D910-75)			Current Military Fuel Grades (MIL-G-5572E) Amendment No. 3		
Grade	Color	Max. TEL ml/U.S. Gal.	Grade	Color	Max. TEL ml/U.S. Gal.	Grade	Color	Max. TEL ml/U.S. Gal.
80/87	red	0.5	80	red	0.5	80/87	red	0.5
91/98	blue	2.0	*100LL	blue	2.0	none	none	none
100/130	green	3.0	100	green	**3.0	100/130	green	**3.0
115/145	purple	4.6	none	none	none	115/145	purple	4.6

* -Grade 100LL fuel in some overseas countries is currently colored green and designated as "100L."
 ** -Commercial fuel grade 100 and grade 100/130 (both of which are colored green) having TEL content of up to 4 ml/U.S. gallon are approved for use in all engines certificated for use with grade 100/130 fuel.

The operation of the aircraft is approved with an anti-icing additive in the fuel. When an anti-icing additive is used it must meet the specification MIL-1-27686, must be uniformly blended with the fuel while refueling, must not exceed .15% by volume of the refueled quantity, and to ensure its effectiveness should be blended at not less than .10% by volume. One and one half liquid ounces per ten gallons of fuel would fall within this range. A blender supplied by the additive manufacturer should be used. Except for the information contained in this section, the manufacturer's mixing or blending instructions should be carefully followed.

CAUTIONS

Assure that the additive is directed into the flowing fuel stream. The additive flow should start after and stop before the fuel flow. Do not permit the concentrated additive to come in contact with the aircraft painted surfaces or the interior surfaces of the fuel tanks.

Some fuels have anti-icing additives pre-blended in the fuel at the refinery, so no further blending should be performed.

Fuel additive can not be used as a substitute for preflight draining of the fuel system drains.

(c) Filling Fuel Tanks

WARNINGS

Do not operate any avionics or electrical equipment on the airplane during refueling. Do not allow open flame or smoking in the vicinity of the airplane while refueling.

During all refueling operations, fire fighting equipment must be available. Two ground wires from different points on the airplane to separate approved grounding stakes shall be used.

Observe all safety precautions required when handling gasoline. Fill the fuel tanks through the filler located on the forward slope of the wing. Each wing holds a maximum of 60 U.S. gallons. When using less than the standard 120 gallon capacity, fuel should be distributed equally between each side.

NOTE

Aircraft should be refueled in a wing level condition. At times this will require alternate filling of left and right tanks until the full condition is reached.

(d) Draining Fuel Strainer, Sumps and Lines

The fuel tank sumps and filter should be drained before the first flight of the day and after refueling. Set fuel selector on left or right tank before draining. The fuel collector/sump tanks, located at the root of each wing, are the lowest points in the system. Each tank drain is accessible through a hole in the bottom wing skin adjacent to the wheel well. The fuel filter drain is located on the right hand side of the fuselage several feet forward of the wing. Sumps and filter should be drained until sufficient fuel has flowed to ensure the removal of any contaminants. When draining sumps, use the end on sampler cup to push in valve, catching fuel in the cup. (Refer to Figure 8-3) To drain filter, hold sampler cup under nylon tube and push in tube. Always inspect fuel for contaminants, water and fuel grade (color). Assure that valves have sealed after draining.

NOTE

Sump drains will lock open if valve is pushed in and turned. Continue turning to release lock.

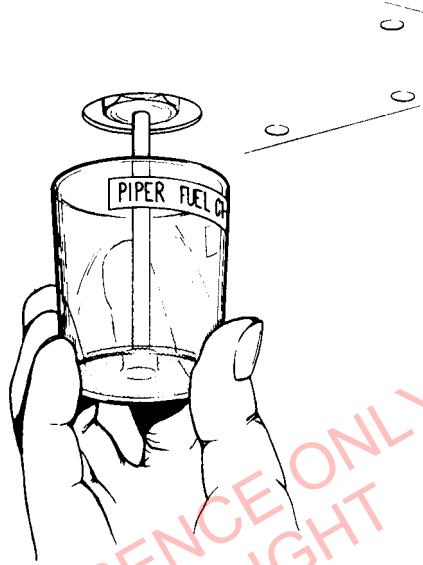

FUEL TANK DRAIN

Figure 8-3

(e) Emptying Fuel System

Drain the bulk of fuel at sump tanks. Set fuel selector on left or right tank. Push in sump drain valves and twist 1/4 turn to lock open. Remaining fuel may be drained through the filter drain. Close sump drain valves before refueling.

CAUTION

Whenever the fuel system is completely drained and fuel is replenished it will be necessary to run the engine for a minimum of three minutes at 1000 RPM on each tank to insure that no air exists in the fuel supply lines.

8.25 TIRE INFLATION

For maximum service from the tires, keep them inflated to the proper pressures - 45 psi for the nose and 40 psi for the main tires. All wheels and tires are balanced before original installation, and the relationship of tire, tube, and wheel should be maintained upon reinstallation. Unbalanced wheels can cause extreme vibration in the landing gear; therefore, in the installation of new components, it may be necessary to rebalance the wheels with the tires mounted. When checking tire pressure, examine the tires for wear, cuts, bruises, and slippage.

8.27 BATTERY SERVICE

Access to the 24-volt battery is gained by opening the forward baggage door and removing the left floor of the forward baggage compartment. The battery should be checked for proper fluid level. **DO NOT** fill the battery above the baffle plates. **DO NOT** fill the battery with acid - use water only. A hydrometer check will determine the percent of charge in the battery.

Inspect overflow sump for presence of battery fluid. Fluid in the sump is not a normal condition and indicates either a battery or charging system problem. If fluid is present, the electrical system must be serviced to eliminate cause and the neutralizer media in the sump jar replaced.

If the battery is not up to charge, recharge starting at a 3 amp rate and finishing with a 1.5 amp rate. Quick charges are not recommended.

8.29 EMERGENCY OXYGEN SYSTEM (OPTIONAL)

The optional emergency oxygen system must be serviced if used. The canister generators must be replaced with new units to restore the emergency system to a useable condition.

8.31 PRESSURIZATION SYSTEM

The system should be given an operational check before each flight. Should the operational check show any malfunction of the pressurization system, refer to the PA-46-310P Service Manual.

8.33 LUBRICATION

For lubricating instructions, a chart showing lubrication points and types of lubricants to be used, and lubrication methods, refer to the PA-46-310P Service Manual.

8.35 CLEANING

(a) Cleaning Engine Compartment

- (1) Place a large pan under the engine to catch waste.
- (2) With the engine cowling removed, spray or brush the engine with solvent or a mixture of solvent and degreaser. In order to remove especially heavy dirt and grease deposits, it may be necessary to brush areas that were sprayed.

CAUTION

Do not spray solvent into the alternator, vacuum pump, starter, or air intakes.

- (3) Allow the solvent to remain on the engine from five to ten minutes. Then rinse the engine clean with additional solvent and allow it to dry.

CAUTION

Do not operate the engine until excess solvent has evaporated or otherwise been removed.

- (4) Lubricate the controls, bearing surfaces, etc., in accordance with the Lubrication Chart in the applicable Service Manual.
- (5) Assure that all engine exhaust deposits and stains are removed frequently from bottom of aircraft around exhaust outlets. *Accumulation of exhaust deposits left even over short periods of time will cause corrosion.*

(b) Cleaning Landing Gear

Before cleaning the landing gear, place a plastic cover or similar material over the wheel and brake assembly.

CAUTION

Do not brush the micro switches.

- (1) Place a pan under the gear to catch waste.
- (2) Spray or brush the gear area with solvent or a mixture of solvent and degreaser, as desired. Where heavy grease and dirt deposits have collected, it may be necessary to brush areas that were sprayed, in order to clean them.
- (3) Allow the solvent to remain on the gear from five to ten minutes. Then rinse the gear with additional solvent and allow to dry.
- (4) Remove the cover from the wheel and remove the catch pan.
- (5) Lubricate the gear in accordance with the Lubrication Chart.

(c) Cleaning Exterior Surfaces

The airplane should be washed with a mild soap and water. Harsh abrasives or alkaline soaps or detergents could make scratches on painted or plastic surfaces or could cause corrosion of metal. Cover areas where cleaning solutions could cause damage. To wash the airplane, use the following procedure:

CAUTION

Do not direct any stream of water or cleaning solutions at the openings in the pitot head, static ports, alternate static ports or fuselage belly drains.

- (1) Flush away loose dirt with water.
- (2) Apply cleaning solution with a soft cloth, a sponge or a soft bristle brush.
- (3) To remove exhaust stains, allow the solution to remain on the surface longer.
- (4) To remove stubborn oil and grease, use a cloth dampened with naphtha.
- (5) Rinse all surfaces thoroughly.
- (6) Any good automotive wax may be used to preserve painted surfaces. Soft cleaning cloths or a chamois should be used to prevent scratches when cleaning or polishing. A heavier coating of wax on the leading surfaces will reduce the abrasion problems in these areas.

(d) Cleaning Windshield and Windows

CAUTION

Use only mild soap and water when cleaning the heated windshield. Use of ANY other cleaning agent or material may cause distortion or damage to windshield coatings.

- (1) Remove dirt, mud and other loose particles from exterior surfaces with clean water.
- (2) Wash with mild soap and warm water or with aircraft plastic cleaner. Use a soft cloth or sponge in a straight back and forth motion. Do not rub harshly.
- (3) Remove oil and grease with a cloth moistened with kerosene.

CAUTION

Do not use gasoline, alcohol, benzene, carbon tetrachloride, thinner, acetone, or window cleaning sprays.

- (4) After cleaning plastic surfaces, apply a thin coat of hard polishing wax. Rub lightly with a soft cloth. Do not use a circular motion.
- (5) A minor scratch or mar in plastic can be removed by rubbing out the scratch with jeweler's rouge. Smooth both sides and apply wax. Deep scratches may lead to failure when pressurized.
- (6) If a deep scratch or crack is found in any of the windshields or windows, do not pressurize cabin until serviced at authorized repair station.

(e) Cleaning Headliner, Side Panels and Seats

- (1) For normal soiling and smudges, simply use the dry cleaning pad provided. This pad contains an exclusive grit-free powder with unusual power to absorb dirt.

Squeeze and twist the pad so the powder sifts through the meshes and adheres to the cloth. Then rub the soiled part in any direction, as hard as necessary to clean.

Even though the pad eventually becomes soiled, this soil will not transfer back to the headliner.

- (2) For simple stains (e.g. coffee, cola) clean headliner with a sponge and a common household suds detergent (e.g. Tide). Dirty grease stains should be first spot cleaned with a lighter fluid containing Naphtha to remove the solvent soluble matter. Any stain residue should then be shampooed with a household upholstery cleaner (e.g. Carbona upholstery and rug shampoo).

With proper care, your Malibu headliner will provide years of excellent appearance and durability.

CAUTION

Solvent cleaners require adequate ventilation.

- (3) Leather should be cleaned with saddle soap or a mild hand soap and water.
- (f) Cleaning Carpets
- To clean carpets, first remove loose dirt with a whisk broom or vacuum. For soiled spots and stubborn stains use a noninflammable dry cleaning fluid. Floor carpets may be cleaned like any household carpet.
- (g) Cleaning Oxygen Equipment
- (1) Clean the mask assemblies with a suitable oil-free disinfectant.
 - (2) Wipe dirt and foreign particles from the unit with a clean, dry, lint-free cloth.
- (h) Cleaning Surface Deicing Equipment*

The deicers should be cleaned when the aircraft is washed using a mild soap and water solution.

In cold weather, wash the boots with the airplane inside a warm hangar if possible. If the cleaning is to be done outdoors, heat the soap and water solution before taking it out to the

*Optional equipment

airplane. If difficulty is encountered with the water freezing on boots, direct a blast of warm air along the region being cleaned using a portable ground heater.

As an alternate cleaning solvent, use benzol or nonleaded gasoline. Moisten the cleaning cloth in the solvent, scrub lightly, and then, with a clean, dry cloth, wipe dry so that the cleaner does not have time to soak into the rubber. Petroleum products such as these are injurious to rubber, and therefore should be used sparingly if at all.

With the deicer boots properly cleaned, a coating of Agemaster No. 1 should be applied as described in the PA-46-310P Service Manual. This treatment helps protect the boot rubber from ozone attack, aging and weathering.

After the Agemaster coating is dry, a coating of B.F. Goodrich Icx may be applied to the boots if icing conditions are anticipated. For specific instructions refer to the PA-46-310P Service Manual.

FOR REFERENCE ONLY
NOT FOR FLIGHT

8.36 CLEANING AND MAINTENANCE OF RELIEF TUBE SYSTEM

When the aircraft is equipped with a relief tube system, the corrosive effects of urine or other liquids poured through the system are extreme and require much attention to the cleanliness of this system both inside and outside of the aircraft. From the interior standpoint, the funnel tube assembly, rubber hose and surrounding sheet metal should be cleaned at termination of flight when the system has been used. Likewise, attention to the exterior of the aircraft is equally as important and must be cleaned as described below.

The corrosive affects of urine on painted and unpainted surfaces cannot be understated. Corrosion may appear in surrounding areas if allowed to go uncleaned for even one day!

(a) Interior

After each use of the relief tube, the area surrounding the relief tube should be examined for spillage and cleaned according to the cleaning procedures listed in paragraphs 8.35(e) and (f) above. Clean area inside the box and access door, funnel and tube using mild soap and water. After cleaning, assure that no soapy residue remains by flushing with clean water. Dry system thoroughly.

CAUTION

Should spillage extending into the fuselage be evident, maintenance actions must occur which include removing panels to access the floor structure to neutralize urine spillage in the aircraft structure.

Prepare to flush the relief tube assembly by placing a catch can underneath the relief tube outlet. Flush tube by pouring a solution of baking soda (10%) and water through the tube, flushing out the entire system. Flush again with at least 1/2 gallon of clear water. (Shop air, at low pressure, may be blown through the relief tube system to dry the system.)

(b) Exterior

Exterior bottom painted surfaces of the aircraft must be cleaned from the firewall to the tip of the tail including the bottom of the tail surfaces, at termination of each flight when the relief tube system has been used. Cleaning should occur in accordance with paragraph 8.35(c) with the following exception: After completion of washing, a solution of baking soda (10%) and water should be applied to the entire area and allowed to remain for a few minutes. The area then must be thoroughly rinsed with clean water. The area should be thoroughly dried and observed for paint chips and corrosion, with touch up as necessary.

FOR REFERENCE ONLY
NOT FOR FLIGHT

TABLE OF CONTENTS

SECTION 9

SUPPLEMENTS

Paragraph/Supplement No.		Page No.
9.1	General	9-1
1	King 150 Series Flight Control System and KAS 297B Vertical Speed And Altitude Selector DELETED.....(1 Page)	9-3
2	King KNS-80 Area Navigation System	(14 Pages) 9-37
3	King KNS-81 Area Navigation System	(12 Pages) 9-51
4	Minneapolis Honeywell (Sperry) WeatherScout Radar System.....	(6 Pages) 9-63
5	Emergency Oxygen	(6 Pages) 9-69
6	Air Conditioning System.....	(4 Pages) 9-75
7	3M (Ryan) Stormscope, WX-10A.....	(6 Pages) 9-79
8	Prop Heat, Heated Windshield Panel and Wing Ice Detection Light.....	(6 Pages) 9-85
9	TI 9000 Loran C Navigator With KAP/KFC 150 Autopilot System	(6 Pages) 9-91
10	Ice Protection System	(16 Pages) 9-97
11	3M (Ryan) Stormscope, WX-11	(6 Pages) 9-113
12	ARNAV R-30 Loran C Navigator and RS08 Series Remote Switch with KAP/KFC 150 Autopilot System	(6 Pages) 9-119
13	Northstar M1 Loran C Navigator with KAP/KFC 150 Autopilot System	(4 Pages) 9-125
14	Supplemental Electric Heater	(6 Pages) 9-129
15	II Morrow, Inc., Apollo II, Model 612, Loran C Navigation System with KAP/KFC 150 Autopilot System	(6 Pages) 9-135
16	Bendix/King RDS 81/82/82VP Digital Weather Radar	(10 Pages) 9-141

**SECTION 9
SUPPLEMENTS**

9.1 GENERAL

This section provides information in the form of supplements which are necessary for efficient operation of the airplane when it is equipped with one or more of the various optional systems and equipment not approved with the standard airplane.

All of the supplements provided in this section are FAA Approved and consecutively numbered as a permanent part of this handbook. The information contained in each supplement applies only when the related equipment is installed in the airplane.

FOR REFERENCE ONLY
NOT FOR FLIGHT

**PILOT'S OPERATING HANDBOOK
AND
FAA APPROVED AIRPLANE FLIGHT MANUAL
SUPPLEMENT NO. 1
FOR
KING 150 SERIES FLIGHT CONTROL SYSTEM
AND
KING KAS 297B VERTICAL SPEED AND ALTITUDE SELECTOR**

This supplement has been DELETED as the FAA Approved Operational Supplement to the Bendix/King 150 Series Flight Control System as installed per STC SA1778CE-D. Effective this revision Bendix/King will be responsible to supply and revise the operational supplement. It is permitted to include the Bendix/King supplement in this location of the Pilots Operating Handbook unless otherwise stated by Bendix/King.

(pages 9-4 through 9-36 DELETED)

**PILOT'S OPERATING HANDBOOK
AND
FAA APPROVED AIRPLANE FLIGHT MANUAL**

**SUPPLEMENT NO. 2
FOR
KING KNS-80 AREA NAVIGATION SYSTEM**

This supplement must be attached to the Pilot's Operating Handbook and FAA Approved Airplane Flight Manual when the King KNS-80 Area Navigation System is installed per Piper Drawing No. 84376-3. The information contained herein supplements or supersedes the information in the basic Pilot's Operating Handbook and FAA Approved Airplane Flight Manual only in those areas listed herein. For limitations, procedures and performance information not contained in this supplement, consult the basic Pilot's Operating Handbook and FAA Approved Airplane Flight Manual.

FAA APPROVED



D. H. TROMPLER
D.O.A. NO. SO.-1
PIPER AIRCRAFT CORPORATION
VERO BEACH, FLORIDA

DATE OF APPROVAL AUGUST 6, 1986

SECTION 1 - GENERAL

This supplement supplies information necessary for the operation of the airplane when the optional King KNS-80 Area Navigation System is installed in accordance with FAA Approved Piper data.

SECTION 2 - LIMITATIONS

- (a) The Area Navigation or VOR PAR mode can only be used with co-located facilities (VOR and DME signals originating from the same geographical location).

SECTION 3 - EMERGENCY PROCEDURES

No change.

SECTION 4 - NORMAL PROCEDURES

GROUND TEST PROCEDURES

The following test can be used to determine if the system is operating properly.

- (a) Tune the KNS 80 to a VORTAC (VOR/DME) within 25 NM of the airplane.
- (b) Place the KNS 80 in VOR mode and rotate the OBS until the course deviation needle centers with the TO/FROM flag giving a FROM indication.
- (c) Using the appropriate controls, select a value for the waypoint radial equal to the OBS value determined in Step (b). In addition, select a value for the waypoint distance equal to the indicated DME value in Step (b).
- (d) Place the KNS 80 in RNAV ENR mode. The system is operating properly if the distance to station is ± 1.0 NM and the course deviation needle is within a dot of being centered.

ENROUTE NAVIGATION

(a) Load Waypoint 1 Data

- (1) Put waypoint 1 in the DSP window by depressing the DSP button. (If there is a 2 in the DSP window initially, push the DSP button three times to go through the 2-3-4-1 sequence to reach 1.)

The previously selected frequency (stored in memory) for waypoint 1 will be displayed and "1" will be flashing unless USE and DSP are the same.

- (2) Select a waypoint 1 frequency using the data input controls which are the two concentric knobs on the right. The smaller of the 2 knobs controls the .1 MHz and .05 MHz digits. The outer knob changes the 1 MHz and 10MHz displays. The selected frequency will appear in the display and be placed in memory.
- (3) Select a waypoint 1 radial by first depressing the DATA button. This will cause the radial for the previous waypoint 1 to appear in the data display over the annunciation RAD. Select the radial with the data input controls. The outer knob controls the 10° and 100° digits; the center knob IN position controls the 1° and the center knob OUT position controls the 0.1° digit. The selected radial will appear in the display and be placed in memory.
- (4) Select a waypoint 1 distance by again depressing the DATA button, causing display of the previous waypoint 1 distance in the data display over the annunciation DST. Select the distance with the data input controls. The outer knob controls the 10 NM digit, the center knob IN position controls the 1 NM digit, and the center knob OUT position controls the 0.1 NM digit. The selected distance will appear in the display and be placed in memory.

NOTE

Throughout this sequence, the number 1 over DSP annunciation will blink. It will stop blinking and remain steady only when the waypoint number in DSP is the same as the waypoint number in USE. This is a safety feature.

(b) Load Remaining Waypoint Data

(1) Put waypoint 2 in the DSP window by depressing DSP button. The data display will automatically display the frequency of the last selected number 2 waypoint and FRQ will be annunciated. All other displays will remain as before. Waypoint 2 may now be loaded the same as waypoint 1 was previously.

(2) The remaining waypoints may be loaded in a similar manner.

(c) Takeoff and Fly to Waypoint 1

Before takeoff, check to be sure that RNV/ENR is still the active mode, then depress the DSP button to place waypoint 1 in the DSP position. The selected waypoint 1 frequency will automatically appear in the data display.

Depress the DATA button to check the radial, and again to check distance in the data display.

Now depress the USE button to place waypoint 1 in the USE position. The number 1 in the DSP position will stop blinking, indicating that the displayed data and "in use" data are the same.

After takeoff, and line of sight altitude is reached, the DME will lock on. The dashes that were present in the distance display of the KNS 80 will disappear and display distance to waypoint 1. CDI or HSI will also be flagged until both VOR and DME are valid.

Ground speed and time-to-station information will not be accurate unless flying directly to or from the VORTAC or waypoint.

CAUTION

When installed, an RMI will continue to display the bearing to the VOR station; it will not display bearing to the RNAV waypoint.

Soon after being on course direct to waypoint 1, ground speed and TTS will become accurate.

At this point you may also want to check the ident of the VOR by pulling the ON/OFF/Volume switch to place it in the OUT position. When satisfied, return the switch to the IN position to mute the ident tones.

(d) Change Over to Waypoint 2

Depress the DSP button and the number 2 will appear (blinking) over the DSP annunciation and the waypoint 2 frequency will appear in the data display. The DME display will not change because waypoint 1 data is still "in use". At this point, if desired, waypoint 2 radial and distance data may be rechecked by depressing the DSP button for each.

When satisfied, depress the USE button to put waypoint 2 data "in use". The number 2 will appear in the USE annunciated space; the number 2 in the DSP space will stop blinking. Waypoint 2 frequency will automatically appear.

Following VOR/DME receiver acquisition of the new VORTAC frequency, distance display will begin reading distance (NM), ground speed (KT) and TTS (MIN) to waypoint 2. The CDI TO/FROM flag will move to the TO position and continue flying course directly to waypoint 2.

(e) Flying Direct to a VOR/DME Facility

(1) Depress the VOR button and RNV/ENR will disappear from the mode annunciator and VOR will appear. The distance display will change to show distance to the VORTAC instead of to the waypoint. Ground speed (KTS) and time-to-station (MIN) displays will also change accordingly.

Center the needle to the CDI and you will be on a course direct to the VORTAC. However, the CDI will display conventional (angular) crosstrack deviation of ± 10 full scale.

- (2) Push the VOR button again and VOR/PAR mode will appear with linear crosstrack deviation displayed on the CDI as ± 5 NM full scale (as in RNV/ENR). This permits flying accurately direct to the station or on a parallel course up to 5 NM either side of the direct course.

CAUTION

Whenever flying directly to or from a VORTAC facility, always select either the VOR or VOR/PAR mode.

- (f) Tune an ILS Frequency Without Losing DME

To retain DME, depress the HOLD button. Now select the ILS frequency using the data input controls and checking it in the data display. HLD will now annunciate. The distance will continue to read to the VORTAC and VOR/PAR function will remain annunciated along with the active ILS function.

Now reselect the same VOR and the ILS annunciation will cancel and it will revert back to VOR/PAR mode. HLD will cancel since VOR and DME frequency are again the same. The DME HOLD button will remain depressed (it is a two position button). Thus the HOLD button functions as a Hold ARM when in the IN position and actual Hold (HLD) annunciation occurs only when VOR/ILS and DME frequencies are different.

If the HOLD function is mistakenly used in the RNAV modes, as soon as the frequency is changed, the HLD function will annunciate, DME displays (NM, KT, and MIN) will flag (display dashes) and the CDI or HSI will flag since this is not a valid RNAV signal. Use of HOLD in VOR PAR mode will result in a CDI or HSI flag and the DME displays will be to the VORTAC on HOLD.

- (g) RNAV Approach

The RNV APR mode may be used for runway location (by placing a waypoint at the approach end of the runway) during an approach to an airport.

If in the RNV ENR mode, depress the RNAV pushbutton and RNV APR mode is immediately activated. In RNV APR the deviation needle on the CDI will display crosstrack deviation as $\pm 1 \frac{1}{4}$ NM full scale, or NM (1519 ft.) per dot. All other aspects of the RNV APR mode are identical with the RNV ENR mode.

Prior to beginning the approach, it is recommended that the waypoints and corresponding waypoint numbers be assigned as follows to reduce pilot workload during the final approach segment:

Waypoint Number

- 1 Use repetitively for initial and intermediate fixes. See note below.
- 2 Final Approach Fix (FAF) Coordinates.
- 3 Missed Approach Point (MAP) Coordinates.
- 4 Missed Approach Fix (MAF) Coordinates.

NOTE

If flying an autopilot coupled approach, the pilot should revert to HEADING mode at the waypoint to make the required course corrections while revising the KNS 80 waypoint 1. Do not adjust the controls for setting waypoint when in RNAV mode or the VOR frequency when USE and DSP are showing the same number and the autopilot is coupled to the KNS 80 system.

FINAL APPROACH PLANNING

If the length of the final approach segment for a given angle of intercept is less than the figures given below, a satisfactory approach will not be obtainable. The figures are in accordance with FAA Advisory Circular 90-45A, Appendix D, guidelines for establishment of IFR approaches.

**MINIMUM LENGTH OF FINAL APPROACH SEGMENT
IN NAUTICAL MILES**

Approach Category	Category Approach Speed Requirements	Magnitude of Turn Over Final Approach Waypoint (Intercept Angle)					
		10°	20°	30°	40°	50°	60°
A	Less than 91 knots	1.0	1.5	2.0	3.0	4.0	5.0
B	91 to 120 knots	1.5	2.0	2.5	3.5	4.5	5.5
C	121 to 140 knots	2.0	2.5	3.0	4.0	5.0	6.0

SECTION 5 - PERFORMANCE

No change.

SECTION 6 - WEIGHT AND BALANCE

Factory installed optional equipment is included in the licensed weight and balance data in Section 6 of the basic Pilot's Operating Handbook.

SECTION 7 - DESCRIPTION AND OPERATION

The KNS 80 is a panel mounted navigation system consisting of a VOR/Localizer Receiver, DME Interrogator, RNAV Computer, and Glide Slope Receiver in a single unit. When combined with an appropriate CDI Indicator, the unit becomes a complete navigation system featuring two modes of VOR, two modes of RNAV, and ILS. The unit also simultaneously displays distance to station (waypoint), velocity to station (waypoint), time to station (waypoint), and chosen parameter (frequency, radial or distance) of one of the four waypoints. Separate system flexibility is maintained with a DME HOLD button which allows "freezing" the DME frequency while tuning to a different ILS or VOR frequency. The various modes, (VOR, VOR PAR, RNV ENR, and RNV APR), are selected by pressing the appropriate VOR or RNAV pushbutton. If an ILS frequency is placed in the active data, the system will automatically go to the ILS mode. When switched out of an ILS frequency the system will revert back to the mode in which it was at the time the ILS frequency was selected.

When energized, the system will go to the mode in which it was when switched off. In addition, it will retain all waypoint data through a power shutdown.

Additional features include an automatic dimming circuit to compensate for changes in ambient light level, and a CMOS memory powered by two silver-oxide watch cells enabling long term waypoint storage (2 years typical cell life). If the batteries should become weak, waypoint storage will be lost and the radio will tune to 110.00 MHz, waypoint 1 in USE and DSP, VOR mode, and dashes in the DME display. The unit may then be operated normally during the flight, but no memory will be retained after turning the radio master switch OFF.

The KNS 80 Digital Area Navigation System consists of the following controls and displays:

DISPLAYS

- (a) NM Display
 - (1) VOR and VOR PAR (VOR Parallel) Modes
 - Displays DME distance.
 - 0 to 99.9 NM in 0.1 NM steps, 100 to 200 NM in 1 NM steps.
 - Most significant digit is zero blanked.
 - Displays dashes whenever DME goes into search.

- (2) RNV APR and RNV ENR Modes
 - Displays RNAV distance to waypoint.
 - 0 to 99.9 NM in 0.1 NM steps, 100 to 400 NM in 1 NM steps.
 - Displays dashes if DME is in search, if VOR flags, if DME and VOR are tuned to different frequencies.

- (b) KT Display
 - (1) VOR and VOR PAR Modes
 - Displays ground speed to the DME ground station.
 - 0 to 999 knots in 1 knot steps.
 - Update rate is once per second.
 - Most significant digit is zero blanked.
 - Displays dashes whenever DME goes into search.
 - (2) RNV APR and RNV ENR Modes
 - Displays ground speed to the active waypoint.
 - 0 to 999 knots in 1 knot steps.
 - Update rate is once per second.
 - Most significant digit is zero blanked.
 - Displays dashes whenever DME goes into search.

- (c) ILS Display
 - Indicates that the frequency in use is an ILS frequency.

- (d) MIN Display
 - (1) VOR and VOR PAR Modes
 - Displays time to DME ground station.
 - 0 to 99 minutes in 1 minute steps.
 - Most significant digit is zero blanked.
 - Displays dashes whenever DME goes into search or when calculated value exceeds 99 minutes.
 - (2) RNV APR and RNV ENR Modes
 - Displays time to the active waypoint.
 - 0 to 99 minutes in 1 minute steps.
 - Most significant digit is zero blanked.
 - Displays dashes if DME is in search, if VOR flags, if DME and VOR are tuned to different frequencies, or if calculated value exceeds 99 minutes.

- (e) FRQ, RAD, DST Display
- (1) FRQ Mode
Displays frequency from 108.00 to 117.95 MHz.
1 MHz digit overflows into (or underflows from) 10 MHz digit.
Rolls over from 118 to 108 or vice versa.
Least significant digit displays only zero or five.
 - (2) RAD Mode
Displays ground station radial on which the waypoint is located from 0.0 to 359.9 degrees.
The two most significant digits are zero blanked.
10 degree digit overflows into (or underflows from) 100 degree digit.
 - (3) DST Mode
Displays the distance offset of the waypoint from the ground station over range of 0.0 to 199.9 NM.
The two most significant digits are zero blanked.
10 NM digit overflows into (or underflows from) 100 NM digit.
The two most significant digits roll over from 190 to 0 NM and vice versa.
- (f) USE Display
Displays waypoint number of data actually being used by system.
In VOR Modes only the frequency has meaning.
Range 1 to 4.
When changed always takes on new value equal to DSP value.
- (g) DSP Display
Displays waypoint number of data being displayed.
Range 1 to 4.
When changed increments by 1.
Rolls over at 4 and blinks when not equal to USE value.
- (h) PAR, VOR, ENR, APR, RNV Displays
System status lights.
- (i) HLD Display
Indicates when the frequency to which the DME is actually tuned is different from the frequency to which the VOR is tuned.
- (j) Course Deviation
Located on remote indicator. When flagged, the needle centers.
- (1) VOR Mode
Full scale sensitivity equals $\pm 10^\circ$.

- (2) VOR PAR Mode
Full scale sensitivity equals 5 NM.
Flagged if VOR or DME data is invalid, or if the VOR and DME are tuned to different channels.
- (3) RNV ENR Mode
Full scale sensitivity equals 5 NM.
Flagged if VOR or DME data is invalid, or if the VOR and DME are tuned to different channels.
- (4) RNV APR Mode
Full scale sensitivity equals 1.25 NM.
Flagged if the VOR or DME data is invalid, or if the VOR and DME are tuned to different channels.
- (5) ILS Mode
Full scale sensitivity equals 3 to 6 degrees (depending upon ground facility).
Flagged if localizer data is invalid.

CONTROLS

- (a) VOR Button
Momentary pushbutton.
When pushed while system is in either RNV mode causes system to go to VOR mode.
When pushed while system is in either VOR mode causes system to toggle between VOR and VOR PAR modes.
- (b) RNAV Button
Momentary pushbutton.
When pushed while system is in either VOR mode causes system to go to RNV ENR mode.
When pushed while system is in either RNV mode causes system to toggle between RNV ENR and RNV APR modes.
- (c) HOLD Button
Two position pushbutton.
When in depressed position inhibits DME from channeling to new frequency.
- (d) USE Button
Momentary pushbutton.
Causes active waypoint to take on same value as displayed waypoint and data display to go to FRQ mode.

- (e) DSP Button
Momentary pushbutton.
Causes displayed waypoint to increment by 1 and data display to go to FRQ mode.
- (f) DATA Button
Momentary pushbutton.
Causes waypoint data display to change from FRQ to RAD to DST and back to FRQ.
- (g) OFF/ON/Ident Control
 - (1) Power OFF-ON/Volume Function
Rotate clockwise for power ON.
 - (2) VOR Audio Level Control
Rotate clockwise for increased audio level.
 - (3) VOR IDENT Mute Function
Push-Pull switch.
Enables the VOR Ident tone to be heard in OUT position.
- (h) Data Input Control
Dual concentric knobs. Center knob has IN and OUT positions.
 - (1) Frequency Data
Outer knob varies 1 MHz digit.
A carry occurs from units to tens position.
Rollover occurs from 117 to 108.
Center knob varies frequency in 50 KHz steps.
 - (2) Radial Data
Outer knob varies 10 degrees digit.
A carry occurs from the tens to hundreds position.
Rollover to zero occurs at 200 NM.
Center knob IN position varies 1 NM digit.
Center knob OUT position varies 0.1 NM digit.
 - (3) Distance Data
Outer knob varies 10 NM digits.
A carry occurs from the tens to hundreds place.
A rollover to zero occurs at 200 NM.
Center knob IN position varies 1 NM digit.
Center knob OUT position varies 0.1 NM digit.
- (i) Course Select Knob
Located in remote unit.
Selects desired course through the VOR ground station or way-point.

For additional information consult the King KNS-80 Pilot's Guide.

FOR REFERENCE ONLY
NOT FOR FLIGHT

**PILOT'S OPERATING HANDBOOK
AND
FAA APPROVED AIRPLANE FLIGHT MANUAL
SUPPLEMENT NO. 3
FOR
KING KNS-81 AREA NAVIGATION SYSTEM**

This supplement must be attached to the Pilot's Operating Handbook and FAA Approved Airplane Flight Manual when the King KNS-81 Area Navigation System is installed per Piper Drawing No. 84388-2. The information contained herein supplements or supersedes the information in the basic Pilot's Operating Handbook and FAA Approved Airplane Flight Manual only in those areas listed herein. For limitations, procedures and performance information not contained in this supplement, consult the basic Pilot's Operating Handbook and FAA Approved Airplane Flight Manual.

FAA APPROVED



D. H. TROMPLER
D.O.A. NO. SO.-1
PIPER AIRCRAFT CORPORATION
VERO BEACH, FLORIDA

DATE OF APPROVAL AUGUST 6, 1986

SECTION 1 - GENERAL

This supplement supplies information necessary for the operation of the airplane when the optional King KNS-81 Area Navigation System is installed in accordance with FAA Approved Piper data.

SECTION 2 - LIMITATIONS

- (a) The Area Navigation may be used as the primary navigation system under IFR conditions on approved approach procedures, approved airways, or random area navigation routes only when approved by Air Traffic Control.
- (b) The Area Navigation (RNAV) modes and the VOR PAR mode may only be used with co-located facilities (VOR and DME signals originate from the same geographical location).

SECTION 3 - EMERGENCY PROCEDURES

No change.

SECTION 4 - NORMAL PROCEDURES

AREA NAVIGATION FUNCTIONAL TEST

The following procedure applies only to airports equipped with, or in range of, a co-located VOR/DME station.

- (a) Place the KNS 81 in VOR mode.
- (b) Find and record the angle from the VOR station by centering the course deviation needle and the TO/FROM flag giving a FROM indication.
- (c) Program a waypoint radial angle equal to the OBS value determined in Step (b).
- (d) Program a waypoint distance equal to the indicated DME value.
- (e) Place the KNS 81 in RNV.

The KNS 81 is operating properly if the distance to waypoint is 0 ± 1.0 NM and the course deviation needle is within a dot of being centered.

PROGRAMMING

Pertinent information (waypoint number, station frequency, waypoint radial, and waypoint distance) for up to nine waypoints is entered into the memory. Programming may be completed prior to takeoff or during the flight. Any combination of navigational facilities (RNAV waypoint, VOR/DME, ILS) may be loaded into the computer; however, it is desirable that each facility be numbered and loaded into the computer in the sequence it will be used.

(a) RNAV WAYPOINTS

- (1) Turn the system on by rotating the ON/OFF switch clockwise.
- (2) Put waypoint 1 in the WPT window by turning the WPT knob. Turn the knob in either direction to get "1".
- (3) Select the waypoint 1 frequency using the data input controls.
- (4) Select the waypoint 1 radial by depressing the DATA button. This will move the >< (caret) from FRQ to RAD. Select the new radial with the data input controls.
- (5) Select the waypoint 1 distance by again depressing the DATA button. This will move the >< from RAD to DST. Select the new distance with the data input controls.
- (6) This completes the programming for the first waypoint. Follow these procedures for all selected waypoints up to a maximum of nine.

(b) CONVENTIONAL VOR

- (1) The programming technique for conventional navigation directly toward or away from a VOR facility without a colocated DME is similar to that for RNAV waypoints. Inputting the waypoint number and frequency into the memory is accomplished in the same manner. The RAD and DST displays will display dashes during VOR and VOR PAR operation.

(c) ILS APPROACH (Front course and Back course)

- (1) Programming an ILS approach is accomplished in the same manner as programming conventional VOR.

(d) MISSED APPROACH

- (1) If the published missed approach utilizes an RNAV waypoint or VOR facility, it may be entered into the memory any time prior to the approach. This is accomplished in the same manner set forth in CONVENTIONAL VOR and RNAV WAYPOINTS in this section.

(e) INFLIGHT

- (1) Preset waypoints may be recalled from memory and put into active use as required.

Turn the WPT knob as required to select the desired waypoint. The preset waypoint number, frequency, radial and distance will appear in their respective displays. The WPT display will blink to indicate that the waypoint displayed is other than the active waypoint.

- (2) Verify that the data is correct.

NOTE

Revisions to the waypoint data can be programmed at this time by entering the new waypoint parameters.

- (3) When return to the active waypoint is desired press the RTN button. The active waypoint, along with its data, will be displayed.
- (4) When navigation to the displayed (blinking WPT) waypoint is desired, press the USE button. The WPT display will cease blinking and the displayed waypoint becomes the active waypoint.

RNAV OPERATION

If the system is receiving valid signals from a co-located VOR-DME facility, it will supply linear deviation information to the Horizontal Situation Indicator (or Course Deviation Indicator). Enroute (RNV) sensitivity, available by turning the MODE selector knob until RNV is displayed, provides a constant course width of +/- 5 NM full scale.

Approach (RNV APR) sensitivity, available by turning the MODE selector knob until RNV APR is displayed, provides a constant course width of +/- 1 1/4 NM full scale. Approach sensitivity should be selected just prior to final approach course interception. Time and distance to the station, and computed ground speed are displayed on the DME display.

CONVENTIONAL VOR OPERATION

VOR or VOR-PAR modes are selected by turning the MODE selector knob until VOR or VOR PAR is displayed. In VOR mode the remote DME is automatically tuned when the KNS 81 is selected as the tuning source. Upon Lock-on, distance, ground speed and time to the VORTAC station will be displayed on the DME display. The HSI (CDI) will display conventional angular crosstrack deviation from the selected course (+/- 10° full scale). In VOR-PAR mode, operation is identical to VOR except the HSI (CDI) will display crosstrack deviation of +/- 5 NM full scale from the selected course. Course width will be constant irrespective of distance from the VORTAC.

Anytime the RAD button is engaged, the radial from the station will be displayed on the DME knots display along with an "F" on the DME time to station display.

NOTE

The RAD switch is not the momentary type, therefore, the switch must be pressed again for the normal DME information to be displayed.

CAUTION

Whenever flying directly to or from a VORTAC facility, always select either the VOR or VOR PAR mode.

ILS OPERATION

Whenever an ILS Frequency is put "IN USE" the mode display will remain the same (either VOR, VOR PAR, RNAV, RNAV APR displayed) but the RAD and DST displays will be blanked. Absence of the LOC/GS functions is annunciated by the NAV and GS flags in the HSI (CDI). Only angular deviation is provided in the ILS mode.

RNAV APPROACH

The RNAV Approach (RNV APR) mode may be used for runway location (by placing a waypoint at the approach end of the runway) during an approach to an airport. Turn the MODE selector knob to select RNV APR. In RNV APR the deviation needle on the HSI (CDI) will display crosstrack deviation of +/- 1 1/4 NM full scale or 1/4 NM (1519 ft) per dot. All other aspects of the RNV APR mode are identical to the RNV mode.

NOTE

Prior to beginning an approach (ILS, RNAV, VOR, etc.), it is recommended that the missed approach navigation fixes be programmed into the KNS 81. This will reduce pilot workload during the final approach segment and subsequent missed approach should this become necessary.

FINAL APPROACH PLANNING

If the length of the final approach segment for a given angle of intercept is less than the figures given below, a satisfactory approach will not be obtainable. The figures are in accordance with FAA Advisory Circular 90-45A, Appendix D, guidelines for establishment of IFR approaches.

**MINIMUM LENGTH OF FINAL APPROACH SEGMENT
IN NAUTICAL MILES**

Approach Category	Category Approach Speed Requirements	Magnitude of Turn Over Final Approach Waypoint (Intercept Angle)					
		10°	20°	30°	40°	50°	60°
A	Less than 91 knots	1.0	1.5	2.0	3.0	4.0	5.0
B	91 to 120 knots	1.5	2.0	2.5	3.5	4.5	5.5
C	121 to 140 knots	2.0	2.5	3.0	4.0	5.0	6.0

SECTION 5 - PERFORMANCE

No change.

SECTION 6 - WEIGHT AND BALANCE

Factory installed optional equipment is included in the licensed weight and balance data in Section 6 of the basic Pilot's Operating Handbook.

SECTION 7 - DESCRIPTION AND OPERATION

The King KNS 81 is a navigation system combining a 200 channel VOR/Localizer receiver, a 40 channel glide slope receiver and a digital RNAV computer with a capability of preselection and storage of 9 VOR/LOC frequencies and 9 sets of RNAV waypoint parameters. A DME System must be used in conjunction with the KNS 81.

The KNS 81 can be operated in any one of three basic modes: VOR, RNAV, or ILS. To change from one mode to another, the rotary MODE selector knob on the left side of panel is used. The ILS Mode is entered automatically whenever an ILS frequency is channeled as the ACTIVE frequency. The display will annunciate the mode by lighting a message beside the WPT display, except in the ILS mode. In this case, the RAD and DST displays are blanked to denote the ILS mode. In addition to the standard VOR and RNAV enroute (RNV) modes, the KNS 81 has a constant course width, or parallel, VOR mode (VOR PAR) and an RNAV approach mode (RNV APR). The same rotary MODE selector knob is used to place the unit in either of these secondary modes.

All waypoint information, station frequency, waypoint distance, and waypoint radial are entered with the increment/decrement rotary switch on the right side of the panel and displayed in their respective displays. The small knob affects the least significant digits while the large knob changes the most significant digits. The tenth's position of waypoint radial and distance can be changed by pulling the small knob to the OUT position. The type of data being selected is indicated by the illuminated carets () located by either FRQ, RAD, or DST. Frequency, radial or distance information for a waypoint can be selected sequentially by pressing the DATA push button. The increment/decrement switch changes only the information being displayed with the carets.

The KNS 81 can store frequency, radial, and distance information for up to nine waypoints. The waypoint number of the data being displayed is located above the message WPT. The waypoint number is changed by rotating the WPT selector knob (small center knob) on the left side of the panel. If the waypoint in use is different than the displayed waypoint (WPT blinking), pressing the USE button will cause the displayed WPT to become the waypoint in use. Additional features include an automatic dimming circuit to compensate for changes in ambient light level and a non-volatile memory. When energized, the system will go to the mode in which it was when switched off. In addition, it will retain all waypoint data through a power shutdown. A non-volatile memory enables indefinite waypoint storage with no batteries required.

The KNS 81 Digital Area Navigation System consists of the following displays and controls (Figure 7-1):

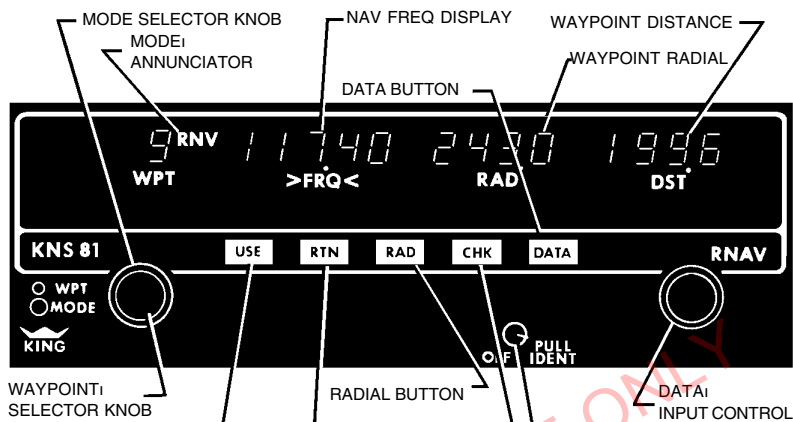

KNS 81 DIGITAL AREA NAVIGATION SYSTEM

Figure 7-1

DISPLAY

(a) FRQ, RAD, DST Display

(1) FRQ Display

Displays frequency from 108.00 to 117.95 MHz in increments of .05 MHz.

Least significant digit displays only zero or five.

Rolls over from 117 to 108 or vice versa.

1 MHz digit overflows into (or underflows from) 10 MHz digit.

(2) RAD Display

Displays ground station radial on which the waypoint is located from 0.0 to 359.9 degrees.

The two most significant digits are zero blanked.

Displays radial from VOR station when CHK button is depressed.

10 degree digit overflows into (or underflows from) 100 degree digit.

Display is dashed in VOR modes and blanked if an ILS frequency is selected.

- (3) DST Display
Displays the offset distance of the waypoint from the ground station over a range of 0.0 to 199.9 NM.
The two most significant digits are zero blanked.
The two most significant digits roll over from 190 to 0 NM and vice versa.
Displays distance from the VORTAC (blanked if VOR) station when CHK button is depressed.
Display is dashed in VOR modes and blanked if an ILS frequency is selected.
- (b) VOR, PAR, RNAV, RNV APR Displays
System mode lights.
- (c) WPT Display
Displays waypoint number (1 to 9) of data being displayed.
WPT display blinks when waypoint number displayed is not the same as that being used.
- (d) Carets (><) Display
Indicates which waypoint data (FRQ, RAD, or DST) the increment/decrement rotary switch will change.
Display is cycled by depressing the DATA button.
- (e) DME Display (Remote)
Displays NM to/from the waypoint/station, KT ground speed and MIN time to the waypoint/station.
Displays bearing from the waypoint/station instead of ground speed when the KNS 81 RAD button is depressed.
Displays F (for FROM) instead of MIN when the KNS 81 RAD button is depressed.
- (f) RMI Display (Optional)
Displays the bearing to the waypoint/station.
- (g) Course Deviation Display
Located on remote indicator. When flagged, the needle centers.
- (1) VOR Mode
Full scale sensitivity equals +/- 10°.
- (2) VOR PAR and RNV Modes
Full scale sensitivity equals +/- 5 NM.
Flagged if VOR or DME data is invalid or if VOR and DME are tuned to different frequencies.

- (3) RNV APR Mode
Full scale sensitivity equals ± 1.25 NM.
Flagged if VOR or DME data is invalid or if VOR and DME or tuned to different frequencies.
- (4) ILS Mode
Full scale sensitivity equals ± 3 to 6 degrees (depending upon ground facility).
Flagged if Localizer data is invalid.
Glide Slope only flagged if GS data is invalid.

CONTROLS

- (a) WPT/Mode Control
Dual concentric knobs.
 - (1) The outer knob selects the MODE of unit operation. Turning the knob clockwise causes the mode to sequence through VOR, VOR PAR, RNV, RNV APR and then back to the VOR mode.
 - (2) The center knob selects the WPT to be displayed. Turning the knob causes the displayed waypoint to increment by one through the waypoint sequence of 1,2,8,9,1.
- (b) USE Button
Momentary pushbutton which, when pressed, causes the active waypoint to take on the same value as the displayed waypoint.
- (c) RTN Button
Momentary pushbutton which, when pressed, causes the active waypoint to return to the display.
- (d) RAD Button
The KNS 81 is normally operated with the RAD button not depressed. Push on, push off button which, when pushed on, causes the radial from the waypoint/station to be displayed instead of ground speed and F to be displayed instead of time on the remote DME display.
- (e) CHK Button
Momentary pushbutton which, when pressed, causes the raw radio data from the NAV Receiver and DME to be displayed. The radial from the VOR Ground Station will be displayed on the RAD display and the distance from the station will be displayed on the DST display. There is no effect on any other data output.

- (f) DATA Button
Momentary pushbutton which, when pressed, causes the caret (><) display to change from FRQ to RAD to DST and back to FRQ.
- (g) OFF/PULL ID Control
Rotary switch/potentiometer which, when turned clockwise, applies power to the KNS 81 and increases NAV audio level. The switch may be pulled out to hear VOR ident.
- (h) DATA INPUT Control
Dual concentric knobs with the center knob having an IN and OUT position.
 - (1) Frequency Data
The outer knob varies the 1 MHz and 10 MHz digits and the center knob varies the frequency in .05 MHz increments with carry to/from the .1 MHz digit regardless of whether the switch is in its IN or OUT position.
 - (2) Distance Data
The outer knob varies the 10 NM digit with a carry over occurring from the tens to hundreds place. The center knob in the IN position varies the 1 NM digit and in the OUT position varies to 0.1 NM digit.
 - (3) Radial Data
The outer knob varies the 10 degree digit with a carry over occurring from the tens to hundreds position. The center knob in the IN position varies the 1° digit and in the OUT position varies the 0.1 degree digit.

For additional information consult the King KNS-81 Pilot's Guide.

**PILOT'S OPERATING HANDBOOK
AND
FAA APPROVED AIRPLANE FLIGHT MANUAL**

**SUPPLEMENT NO. 4
FOR
MINNEAPOLIS HONEYWELL(SPERRY)
WEATHERSCOUT WEATHER RADAR SYSTEM**

This supplement must be attached to the Pilot's Operating Handbook and FAA Approved Airplane Flight Manual when the Minneapolis Honeywell (Sperry) WeatherScout Weather Radar System is installed per Piper Drawing 84398-2. The information contained herein supplements or supersedes the information in the basic Pilot's Operating Handbook and FAA Approved Airplane Flight Manual only in those areas listed herein. For limitations, procedures, and performance information not contained in this supplement, consult the basic Pilot's Operating Handbook and FAA Approved Airplane Flight Manual.

FAA APPROVED:



D. H. TROMPLER
D.O.A. NO. SO-1
PIPER AIRCRAFT CORPORATION
VERO BEACH, FLORIDA

DATE OF APPROVAL: August 1, 1986

SECTION 1 - GENERAL

This supplement supplies information necessary for the operation of the airplane when the optional Minneapolis Honeywell (Sperry) WeatherScout Weather Radar System is installed.

SECTION 2 - LIMITATIONS

Do not operate the radar during refueling operation or in the vicinity of trucks or containers accomodating flammables or explosives. Do not allow personnel within 15 feet of area being scanned by antenna when system is transmitting.

SECTION 3 - EMERGENCY PROCEDURES

No change.

**FOR REFERENCE ONLY
NOT FOR FLIGHT**

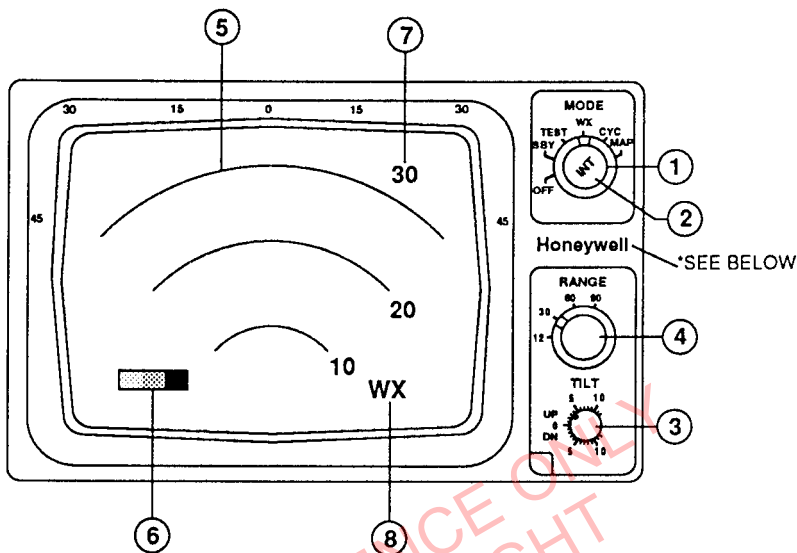

*Honeywell now owners of Sperry

INDICATOR CONTROLS AND DISPLAY FEATURES

- (1) MODE Selector
- a. OFF All power is off.
 - b. SBY Standby mode is used for system warmup. The antenna is not radiating energy in SBY.
 - c. TEST Weather colors are displayed for preflight test.
 - d. WX Normal weather detection mode.
 - e. CYC Cyclic contour mode activates alternate flashing of red, intense storm cells, with a black background color for added warning emphasis.
 - f. MAP Activates ground mapping for identification of prominent terrain features.
- (2) INT Rotary control used to regulate brightness (INTensity) of display.

- | | |
|------------------------------|--|
| (3) TILT | Rotary control used to adjust antenna elevation position. Control indexes increments of tilt from 0 to 12 degrees up or down. |
| (4) RANGE
12/30/60/90 | Rotary switch used to select one of four ranges. |
| (5) Range Field | Maximum selected range is displayed. Maximum range is always displayed when indicator is in on-condition. |
| (6) Test Field | Test block displays three illumination levels. |
| (7) Range Mark
Identifier | Individual label displayed for each range mark. |
| (8) Mode Field | Operating mode is displayed as WX or CYC.

When system is first turned on, WAIT is displayed until system times out (30-40 seconds). |

(b) **PRELIMINARY CONTROL SETTINGS**

Place the Indicator controls in the following positions before applying power from the aircraft electrical system:

MODE selector.....OFF
INTensity control.....Fully counterclockwise
TILT controlFully upward
RANGE switch.....12 nautical miles

(c) **OPERATIONAL CONTROL SETTINGS**

- (1) Rotate MODE selector clockwise to SBY to bring system into ON condition.
- (2) Note that WAIT is displayed during warm-up period of 30-40 seconds.
- (3) Rotate MODE selector to desired operating mode.
- (4) Set RANGE switch to desired range.
- (5) Adjust TILT control for desired forward scan area.

(d) **PRECAUTIONS**

- (1) If the radar is to be operated while the aircraft is on the ground, direct nose of aircraft such that antenna scan sector is free of large metallic objects (hangars, other aircraft) for a distance of 100 yards (90 meters), and tilt antenna fully upward.

WARNING

Do not operate the radar during refueling operations or in the vicinity of trucks or containers accommodating flammables or explosives; do not allow personnel within 15 feet of area being scanned by antenna when system is transmitting.

- (2) Flash bulbs can be exploded by radar energy.
- (3) Since storm patterns are never stationary, the display is constantly changing. Continued observation is always advisable in stormy areas.

SECTION 5 - PERFORMANCE

No change.

SECTION 6 - WEIGHT AND BALANCE

Factory installed optional equipment is included in the licensed weight and balance data in Section 6 of the basic Pilot's Operating Handbook.

**PILOT'S OPERATING HANDBOOK
AND
FAA APPROVED AIRPLANE FLIGHT MANUAL
SUPPLEMENT NO. 5
FOR
EMERGENCY OXYGEN SYSTEM**

This supplement must be attached to the Pilot's Operating Handbook and FAA Approved Airplane Flight Manual when the Emergency Oxygen System is installed per Piper Drawing No. 83985-2. The information contained herein supplements or supersedes the information in the basic Pilot's Operating Handbook and FAA Approved Airplane Flight Manual only in those areas listed herein. For limitations, procedures and performance information not contained in this supplement, consult the basic Pilot's Operating Handbook and FAA Approved Airplane Flight Manual.

FAA APPROVED



D. H. TROMPLER
D.O.A. NO. SO.-1
PIPER AIRCRAFT CORPORATION
VERO BEACH, FLORIDA

DATE OF APPROVAL AUGUST 6, 1986

SECTION 1 - GENERAL

This supplement supplies information necessary for the operation of the airplane when the optional Emergency Oxygen System is installed in accordance with FAA Approved Piper Data.

SECTION 2 - LIMITATIONS

The following placard is installed on the right cabin side panel, immediately forward of the copilot's air vent, and the right aft facing seat, aft of the air vent.

EMERGENCY OXYGEN

**IN DRAWER UNDER SEAT PULL MASK
OUT OF DRAWER FULLY AT FULL
EXTENSION GIVE CORD A TUG
MAXIMUM DURATION - 15 MINS**

SEE POH

NO SMOKING WHILE IN USE

FOR REFERENCE ONLY
NOT FOR FLIGHT

SECTION 3 - EMERGENCY PROCEDURES

In the event that the emergency oxygen system is needed, proceed as follows:

- Mask compartment(s)OPEN
MasksREMOVE and extend lanyard
to full length; tug to activate
generator. Unfold and don
mask(s).
Flow Indicator(s)green area in bottom
of accumulator INFLATES,
indicating oxygen flow.
Cabin AltitudeREDUCE to 12,500
or lower before the 15 minute
oxygen supply is fully depleted.

NOTE

Descent should be started as soon as possible in order to assure that flow rate remains adequate throughout the descent. Refer to SECTION 3 of the basic POH and FAA Approved AFM for emergency descent procedures. This system, once activated, cannot be turned off.

WARNING

No smoking while oxygen is in use. Remove oil and grease (including lipstick, chapstick, makeup, etc.) before using oxygen.

SECTION 4 - NORMAL PROCEDURES

Prior to each flight, turn on the master switch and check that the amber OXYGEN annunciator light is not illuminated. If the annunciator is illuminated, one or more of the oxygen generators should be replaced. In addition, check the oxygen masks and hoses for accessibility and condition.

SECTION 5 - PERFORMANCE

No change.

SECTION 6 - WEIGHT AND BALANCE

Factory installed optional equipment is included in the licensed weight and balance data in Section 6 of the Airplane Flight Manual.

SECTION 7 - DESCRIPTION AND OPERATION OF THE EMERGENCY OXYGEN SYSTEM

The optional emergency oxygen system consists of three "two-man" chemical oxygen generators, which provide sufficient oxygen flow for six people, during a descent from 25,000 feet to 12,000 feet or below, for a 15 minute time period. Once an oxygen generator is activated, it will continue to produce oxygen until depleted; no shut-off provisions are provided. Each generator has two oxygen masks connected, either of which is capable of activating the generator. The masks are accessible from each crew/passenger seat.

The system consists of two major assemblies, the crew assembly and the passenger assembly.

The crew assembly is located under the copilot's seat and contains one two-man oxygen generator and two masks mounted on a sliding tray. The tray is accessible from the aisle between the pilot's and copilot's seats and is pulled out from under the seat to expose the two masks. Each mask is connected to the generator with a clear plastic tube and lanyard. The tube delivers oxygen to the mask when the lanyard is pulled out, releasing the firing mechanism, which activates a chemical reaction within the oxygen generator. Each generator has two over-pressure relief valves to prevent excessive pressure in the generator, in the event of a malfunction or delivery tube restriction. When activated, the generator delivers oxygen to both attached masks simultaneously.

The passenger assembly is located in the drawer in the right aft facing passenger seat base. The drawer is accessible from the aft side of the base, under the seat bottom and is pulled aft to expose the four masks. The two inboard masks are attached to one generator, while the two outboard masks are attached to the second generator. Either of the four masks will reach any of the four passenger seat locations. Activation of the generators is the same as the crew installation; pulling out the lanyard attached to the mask. Operation of the passenger provisions are identical to that of the crew.

Placards are provided on the side panel outboard of the copilot's seat and the right aft facing seat, stating the location and operation of the oxygen system, and that smoking is prohibited while oxygen is in use.

An amber OXYGEN annunciator is provided to inform the crew whenever either of the three oxygen generators has been activated. The annunciator light is operated by a micro switch adjacent to each generator firing mechanism. The light will continue to be illuminated until the generator is replaced with a full one with an untripped firing mechanism.

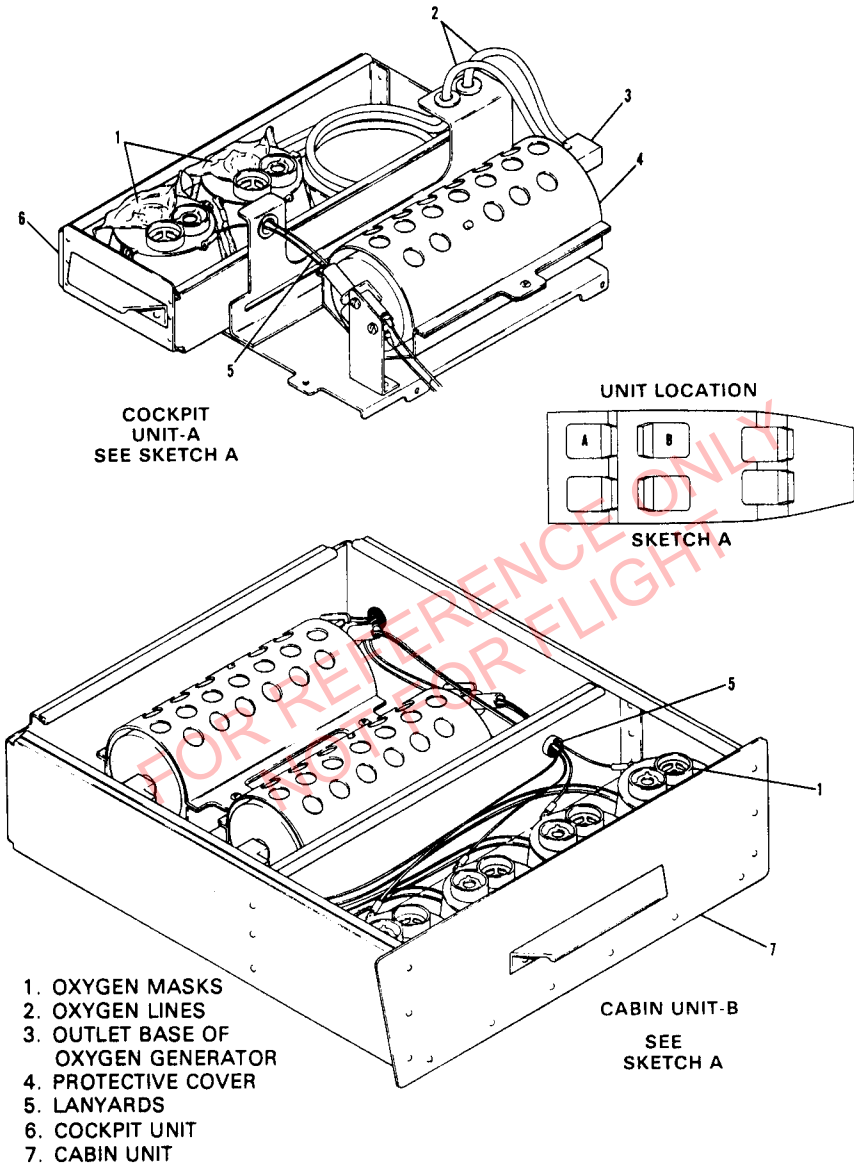

OXYGEN SYSTEM INSTALLATION

Figure 7-1

**PILOT'S OPERATING HANDBOOK
AND
FAA APPROVED AIRPLANE FLIGHT MANUAL
SUPPLEMENT NO. 6
FOR
AIR CONDITIONING SYSTEM**

This supplement must be attached to the Pilot's Operating Handbook and FAA Approved Airplane Flight Manual when the Air Conditioner System is installed per Piper Drawing No. 83870-2. The information contained herein supplements or supersedes the information in the basic Pilot's Operating Handbook and FAA Approved Airplane Flight Manual only in those areas listed herein. For limitations, procedures and performance information not contained in this supplement, consult the basic Pilot's Operating Handbook and FAA Approved Airplane Flight Manual.

FAA APPROVED



D. H. TROMPLER
D.O.A. NO. SO.-1
PIPER AIRCRAFT CORPORATION
VERO BEACH, FLORIDA

DATE OF APPROVAL AUGUST 6, 1986

SECTION 1 - GENERAL

This supplement supplies information necessary for the operation of the airplane when the optional Air Conditioning System is installed in accordance with FAA Approved Piper Data.

SECTION 2 - LIMITATIONS

AIR COND/BLWR switch in OFF or BLWR position for takeoffs and landings.

NOTE

REC BLWR switch may be in HIGH or LOW position.

SECTION 3 - EMERGENCY PROCEDURES

Alternator failure (ALTERNATOR annunciator light illuminated.)

AIR COND/BLWR switchOFF

Freon compressor failure.

AIR COND/BLWR switch.....OFF or BLWR

SECTION 4 - NORMAL PROCEDURE

AIR CONDITIONING SYSTEM OPERATION.

To turn air conditioning ON:

AIR COND/BLWR switchAIR COND

REC BLWR switch.....HIGH or LOW as desired

To turn air conditioning OFF:

AIR COND/BLWR switch.....OFF or BLWR

SECTION 5 - PERFORMANCE

Operation of the air conditioner will cause slight decreases in cruise speed and range. Power from the engine is required to run the compressor. Although the cruise speed and range are only slightly affected by the air conditioner operation, these changes should be considered in preflight planning. To be conservative, decrease the true airspeed 1 knot while operating the air conditioner.

NOTE

To insure maximum climb performance the air conditioner must be turned off manually before takeoff and landing.

SECTION 6 - WEIGHT AND BALANCE

Factory installed optional equipment is included in the licensed weight and balance data in Section 6 of the basic Pilot's Operating Handbook.

FOR REFERENCE ONLY
NOT FOR FLIGHT

SECTION 7 - DESCRIPTION AND OPERATION

The cabin air conditioning system is a vapor cycle system using refrigerant R-12. The freon compressor is engine driven and the condenser cooling airflow is provided by a continuous duty motor and fan. Cabin air (regardless of source) is recirculated across the evaporators to provide cool air at each seat outlet.

The system controls are located on the pilot's instrument panel, to the left of the pilot's control wheel, together with other system switches. They consist of two switches; AIR COND/OFF/BLWR and REC BLWR HIGH/LOW. It is possible to operate the cabin fan, without the air conditioning system on, for the recirculation air flow only. The air conditioning system must be OFF to insure normal takeoff climb performance.

The condenser and cooling air supply fan are located in the tailcone, immediately aft of the rear pressure bulkhead. Cooling air is pulled into the cooling air duct, from the outside of the tailcone, thru a flush opening in the skin, routed across the condenser coil and discharged into the tailcone. The tailcone exit opening provides a path for discharging the air overboard.

The evaporator assemblies (two) are located aft of each rear seat, below the rear baggage compartment floor. Air is drawn into each evaporator from grills in the floor structure behind each seat, thru each evaporator coil using squirrel cage blowers, and discharged into ducts connected to each cabin side wall duct. Outlets are located at each seat in the airplane.

The freon portion of the system also incorporates a receiver dryer, with sight gauge, suction and discharge service valves, and high pressure (265 psi) and low pressure (40 psi) switches. Should the compressor discharge pressure increase above 265 psi, or decrease below 40 psi, the clutch will disengage the freon compressor.

**PILOT'S OPERATING HANDBOOK
AND
FAA APPROVED AIRPLANE FLIGHT MANUAL**

**SUPPLEMENT NO. 7
FOR
3M (RYAN) STORMSCOPE, WX-10A**

This supplement must be attached to the Pilot's Operating Handbook and FAA Approved Airplane Flight Manual when the optional WX-10A Stormscope system is installed per Piper Dwg. 84634-2. The information contained herein supplements or supersedes the information in the basic Pilot's Operating Handbook and FAA Approved Airplane Flight Manual only in those areas listed herein. For limitations, procedures and performance information not contained in this supplement, consult the basic Pilot's Operating Handbook and FAA Approved Airplane Flight Manual.

FAA APPROVED

D. H. Trompler

D. H. TROMPLER
D.O.A. NO. SO.-1
PIPER AIRCRAFT CORPORATION
VERO BEACH, FLORIDA

DATE OF APPROVAL AUGUST 6, 1986

SECTION 1 - GENERAL

This supplement supplies information necessary for the operation of the airplane when the optional WX-10A Stormscope system is installed in accordance with FAA Approved Piper data.

SECTION 2 - LIMITATIONS

- (a) The WX-10A Stormscope system signal displays are not intended for the purpose of penetrating thunderstorm areas or areas of severe turbulence; such intentional use is prohibited.

NOTE

Range selector determines receiver sensitivity and therefore relative range. Displayed range is based on signal strength and is not to be used for accurate determination of thunderstorm location.

- (b) Allow 30 seconds warm-up time before activating test functions.
- (c) Placards

Located on the top of the throttle quadrant near the Stormscope:

**STORMSCOPE NOT TO BE USED FOR
THUNDERSTORM AREA PENETRATION**

SECTION 3 - EMERGENCY PROCEDURES

No change.

SECTION 4 - NORMAL PROCEDURES

The 3M (Ryan) Stormscope, WX-10A Owners Manual, should be read thoroughly by the operator before using the displayed data to interpret thunderstorm activities.

(a) Operation (Pre-Flight)

- (1) Turn power/mode switch to ON.
- (2) Turn WX-10A to FWD, if desired, to concentrate system memory to forward 180° reception.
- (3) Push test button, TST. Check for proper signal reception on the 45° bearing. Check that signal reception occurs at both 100 NM range and 200 NM scale selections. No signal will normally be seen on the 50/25 NM scales.
- (4) Push clear button, CLR, to clear dots from screen so new thunderstorm data can be displayed.
- (5) Turn Range-Selection switch to desired range in nautical miles.
- (6) For night operation, the brightness control, BRT, controls intensity of dots for comfortable viewing.

NOTE

Operator should be aware that occasional aircraft electrical system (pitot heat, radio transmissions, etc.) activations or noisy external electrical devices in close ground proximity may cause signal patterns to be displayed. Such signals should be disregarded and cleared by the CLR button.

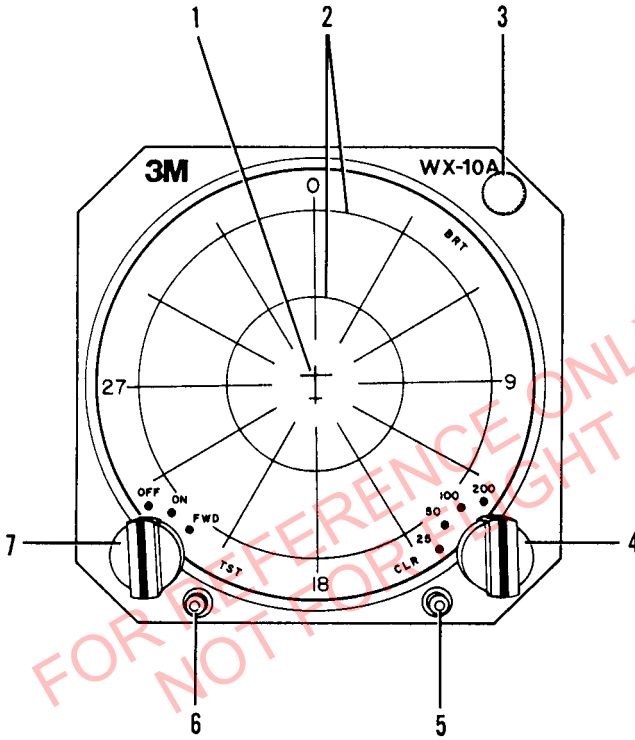

1. MAPPING DIRECTION INDICATOR
2. MAPPING LINES
3. BRIGHTNESS CONTROL
4. RANGE SELECTION SWITCH
5. CLEAR BUTTON
6. TEST BUTTON
7. POWER MODE SWITCH

WX-10A STORMSCOPE

Figure 4-1

(b) IN-FLIGHT FUNCTIONS

- (1) The WX-10A has the capacity to show up to 256 dots on the display screen. When in FWD mode all dots will be concentrated on the upper half of the screen to give greater definition of thunderstorm activity ahead of the airplane. No warnings will be received from the rear half of the display.
- (2) The size and shape of the cluster of dots will indicate how concentrated or sparse the electrical discharges are at the thunderstorm location.

The rapidity at which the individual dots appear indicate the rate of occurrence of the electrical discharges and generally the thunderstorm severity.

The dot patterns will update automatically anywhere from approximately 10 seconds to 5 minutes depending upon the nature and severity of the detected disturbances by automatic erasure of oldest signals and display of newly detected signals. A random, scattered display of signals may only indicate possible areas of atmospheric instability rather than significant thunderstorm activity.

Read the owners manual for complete explanation and interpretation of dots.

- (3) The push test button, TST, may be used in-flight to verify proper operation of the system.

SECTION 5 - PERFORMANCE

No change.

SECTION 6 - WEIGHT AND BALANCE

Factory installed optional equipment is included in the licensed weight and balance data in the Equipment List attached to the Pilot's Operating Handbook.

SECTION 7 - DESCRIPTION AND OPERATION

The 3M (Ryan) Stormscope, WX-10A, weather mapping system provides a visual screen readout of the electrical discharges associated with thunderstorms. This information with proper interpretation, will allow the pilot to detect severe thunderstorm activity. A series of green dots will be displayed on the screen to indicate the electrical discharge areas. The display scope provides full scale selectable ranges of 200, 100, 50 and 25 nautical miles along with 30 azimuth sectors.

**FOR REFERENCE ONLY
NOT FOR FLIGHT**

PILOT'S OPERATING HANDBOOK
AND
FAA APPROVED AIRPLANE FLIGHT MANUAL
SUPPLEMENT NO. 8
FOR
PROP HEAT, HEATED WINDSHIELD PANEL AND
WING ICE DETECTION LIGHT

This supplement must be attached to the Pilot's Operating Handbook and FAA Approved Airplane Flight Manual when any or all of the following equipment is installed per the appropriate Piper Drawing: Prop Heat - Dwg. No. 83980, Heated Windshield Panel - Dwg. No. 83981 and Wing Ice Detection Light - Dwg. No. 83978.

The information contained herein supplements or supersedes the information in the basic Pilot's Operating Handbook and FAA Approved Airplane Flight Manual only in those areas listed herein. For limitations, procedures and performance information not contained in this supplement, consult the basic Pilot's Operating Handbook and FAA Approved Airplane Flight Manual.

FAA APPROVED



D. H. TROMPLER
D.O.A. NO. SO.-1
PIPER AIRCRAFT CORPORATION
VERO BEACH, FLORIDA

DATE OF APPROVAL AUGUST 6, 1986

SECTION 1 - GENERAL

This supplement supplies information necessary for the operation of the airplane when the optional prop heat, heated windshield panel, and wing ice detection light are installed in accordance with FAA Approved Piper data.

SECTION 2 - LIMITATIONS

- (a) This aircraft is not approved for flight in icing conditions.
- (b) Under no circumstances should the heated windshield panel be turned on for a period exceeding 30 seconds unless the aircraft is in flight.

SECTION 3 - EMERGENCY PROCEDURES

No change.

SECTION 4 - NORMAL PROCEDURES

Prior to flight, the equipment should be functionally checked for proper operation.

An operational check of the heated windshield panel is accomplished by turning the W SHLD HEAT switch ON for a period not exceeding 30 seconds. Proper operation is indicated by the heated panel being warm to the touch.

NOTE

A safety feature prevents activation of the panel at ambient temperatures above approximately 75°F. In this case an operational check must be performed in flight by turning the W SHLD HEAT switch ON and observing the ammeter for an increase in load.

A check of the heated propeller can be performed by turning the PROP HEAT switch ON and feeling the de-ice pads. The pads should become warm to the touch.

SECTION 5 - PERFORMANCE

No change.

SECTION 6 - WEIGHT AND BALANCE

Factory installed optional equipment is included in the licensed weight and balance data in Section 6 of the Airplane Flight Manual.

SECTION 7 - DESCRIPTION AND OPERATION OF PROP HEAT, HEATED WINDSHIELD PANEL AND WING ICE DETECTION LIGHT

The presence of one or more items of de-icing equipment does not imply the capability to fly into forecast or known icing. The equipment is provided to enlarge the options available to the pilot as he takes appropriate action to avoid icing that is inadvertently encountered.

Controls for the components are located to the right of the control quadrant on the auxiliary switch panel (Figure 7-1).

WING ICE DETECTION LIGHT

Wing icing conditions may be detected during night flight by use of an ice detection light installed on the left side of the forward fuselage. The light is controlled by an ICE LIGHT switch (Figure 7-1) located on the de-ice switch panel. Circuit protection is provided by an ICE circuit breaker located in the LIGHT section of the circuit breaker panel.

PROP HEAT

Electrothermal propeller heat pads are bonded to a portion of the leading edges of the propeller blades. The system is controlled by an ON-OFF type PROP HEAT switch (Figure 7-1) located on the auxiliary switch panel. Power for the prop heat is supplied by the aircraft electrical system through a PROP HEAT circuit breaker on the circuit breaker panel. When the PROP HEAT switch is actuated, power is applied to a timer through the PROP HEAT ammeter which monitors the current through the prop heat system.

Power from the timer is cycled to brush assemblies which distribute power to slip rings. The current is then supplied from the slip rings directly to the electrothermal propeller heat pads.

The Hartzell propeller is heated in a cycle which applies power to the heat pads for approximately 90 seconds and then shuts off for approximately 90 seconds. Once begun, cycling will proceed in the above sequence and will continue until the system is turned off. The PROP HEAT ammeter should indicate within the green shaded area during the portion of the cycle when power is being applied. This indicates proper operation of the system.

The propeller designation is: BHC-C2YF-1BF/F8052()

ELECTRIC WINDSHIELD PANEL

An electrically heated windshield panel is installed on the exterior of the pilot's windshield. The panel is heated by current from the aircraft electrical system and controlled by an ON-OFF type W SHLD HEAT switch located on the auxiliary switch panel.

The panel is equipped with a temperature sensing device which automatically turns the panel on and off during operation to maintain the desired operating characteristics. This feature also prevents activation of the panel at ambient temperatures above approximately 75°F. With ambient temperatures above 75°F an operational check must be performed in flight after the temperature has decreased.

The ammeter must be observed for an increase in load when the W SHLD HEAT switch is activated to indicate proper operation of the panel.

WARNING

Flight into known or forecast icing is not approved. If icing is encountered, take avoidance action immediately.

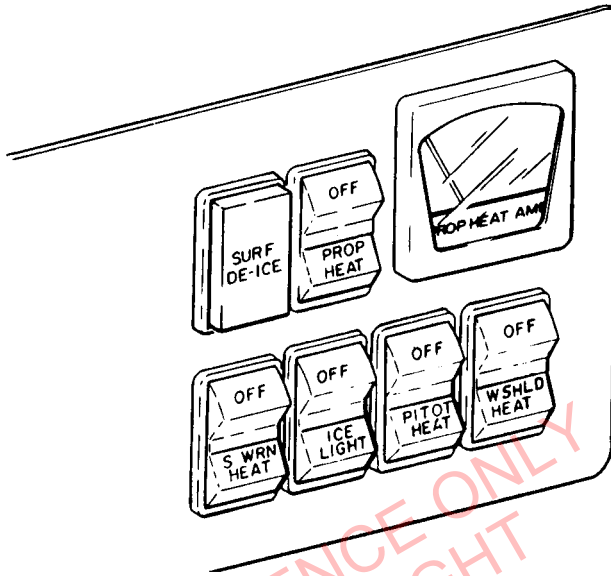

AUXILIARY SWITCH PANEL

Figure 7-1

**PILOT'S OPERATING HANDBOOK
AND
FAA APPROVED AIRPLANE FLIGHT MANUAL
SUPPLEMENT NO. 9
FOR
TI 9100 LORAN C NAVIGATOR
WITH KAP/KFC 150 AUTOPILOT SYSTEM**

This supplement must be attached to the Pilot's Operating Handbook and FAA Approved Airplane Flight Manual when the optional TI 9100 Loran C Navigator is installed per the Equipment List. The information contained herein supplements or supersedes the basic Pilot's Operating Handbook and FAA Approved Airplane Flight Manual only in those areas listed herein. For limitations, procedures and performance information not contained in this supplement, consult the basic Pilot's Operating Handbook and FAA Approved Airplane Flight Manual.

FAA APPROVED



D. H. TROMPLER
D.O.A. NO. SO.-1
PIPER AIRCRAFT CORPORATION
VERO BEACH, FLORIDA

DATE OF APPROVAL AUGUST 6, 1986

SECTION 1 - GENERAL

This supplement supplies information necessary for the operation of the airplane when the optional TI 9100 Loran C Navigator System is installed. The navigator system must be operated within the limitations herein specified. The information contained within this supplement is to be used in conjunction with the complete handbook.

This supplement has been FAA Approved as a permanent part of this handbook and must remain in this handbook at all times when the TI 9100 Loran C Navigator System is installed.

SECTION 2 - LIMITATIONS

- (a) The TI 9100 Loran C Navigator Operator's Manual (P/N 2584485-1 dated 1981, Revision A, dated October 1, 1982) must be immediately available to the flight crew whenever navigation is predicated on the use of the TI 9100.
- (b) VFR RNAV operation of the TI 9100 is limited to the 48 contiguous states, and the District of Columbia.

IFR RNAV operation is limited to the 48 contiguous states, the District of Columbia and offshore areas with the following exclusions: See chart, page A1, in the operator's manual.
- (c) During RNAV operation of the TI 9100 additional navigation equipment required for the specific type of operation must be installed and operable.
- (d) The TI 9100 Loran C Navigator is not approved for IFR approaches.
- (e) During operation no flight operation shall be predicated upon the TI 9100 Loran C Navigator whenever a NAV flag is displayed by the CDI or when in automatic operation whenever a set status of 2 or lower or in manual operation whenever the CYC indicator is ON or the degrees and minutes annunciator is flashing on the TI 9100 Loran C Navigator display.

- f) If a GRI change is required while in flight, the following Caution should be noted:

CAUTION

When changing GRI in flight, expect to navigate DR for approximately 2 minutes waiting for acquisition of new GRI.

SECTION 3 - EMERGENCY PROCEDURES

No changes to the basic Emergency Procedures provided by Section 3 of this Pilot's Operating Handbook are necessary for this supplement.

SECTION 4 - NORMAL PROCEDURES

(a) OPERATION

Normal operating procedures are outlined in the TI 9100 Loran C Navigator Operator's Manual (P/N 2584485-1 dated 1981, Revision A, dated October 1, 1982).

(b) NAV-COUPLED MODE

When operating the KAP/KFC 150 flight control system in either the navigation (NAV) or approach (APR) mode and the NAV/LORAN switch has been set to the TI 9100 as the navigation source, all operational procedures which are applicable to these two modes, as described in the KAP/KFC 150 Operator's Manual and Flight Manual Supplement, still apply, with the following notations or exceptions:

- (1) TI 9100 is not approved for IFR approaches.
- (2) Course deviation data for the autopilot is derived from the TI 9100.
- (3) For course intercept or course tracking, set the HSI course needle to the Loran C course to be flown. This setting provides course datum to the autopilot.

(4) Autopilot Nav Select Switch Positions

NAV/LORAN SW	A/P NAV 1 NAV 2 A/P SW	Selections
NAV.	A/P NAV 1	NAV 1 coupled to A/P Displayed on H.S.I.
NAV.	A/P NAV 2	NAV 2 coupled to A/P displayed on NAV 2 indicator
LORAN	*	LORAN coupled to A/P displayed on H.S.I. (Blue Indicator light)

* When the NAV/LORAN switch is in the Loran mode the A/P NAV 1/
NAV 2 A/P autopilot coupling switch is inactive.

(c) NAVIGATION DISPLAYS

The Loran C System drives the pilot's HSI display when manually selected by the NAV/LORAN switch. This configuration is annunciated by a mode light adjacent to the HSI. The HSI will only display left or right course information, to/from flags and a Off/Warning flag indication from the TI 9100. The course selector pointer must be manually set to the Loran C course. (Actual course cannot be determined on the HSI by rotating the course selector pointer).

When Loran has been selected for display on the HSI, the bearing pointer will continue displaying the bearing to a previous selected VOR or RNAV waypoint or NDB. Caution must be used in noting that the pointer will not indicate the bearing to the Loran waypoint.

(d) COMPUTER PROGRAM IDENTIFICATION

The TI 9100 Loran C Navigator Computer Program identification number is displayed by the key sequence listed below. The displayed number should represent the computer program version shown in the TI 9100 Loran C Navigator Operator's Manual.

KEY	DISPLAY
2ND	
MON	
5	A371

SECTION 5 - PERFORMANCE

Installation of the TI 9100 Loran C Navigator does not affect the basic performance information presented in Section 5 of this Pilot's Operating Handbook.

FOR REFERENCE ONLY
NOT FOR FLIGHT

**PILOT'S OPERATING HANDBOOK
AND
FAA APPROVED AIRPLANE FLIGHT MANUAL
SUPPLEMENT NO. 10
FOR
ICE PROTECTION SYSTEM
(APPROVED FOR FLIGHT INTO KNOWN ICING CONDITIONS)**

This supplement must be attached to the Pilot's Operating Handbook and FAA Approved Airplane Flight Manual when Ice Protection System, per Piper Drawing No. 83965-2, is installed. The information contained herein supplements or supersedes the information in the basic Pilot's Operating Handbook and FAA Approved Airplane Flight Manual only in those areas listed herein. For limitations, procedures and performance information not contained in this supplement, consult the basic Pilot's Operating Handbook and FAA Approved Airplane Flight Manual.

FAA APPROVED



D. H. TROMPLER
D.O.A. NO. SO-1
PIPER AIRCRAFT CORPORATION
VERO BEACH, FLORIDA

DATE OF APPROVAL AUGUST 6, 1986

SECTION 1 - GENERAL

This supplement supplies information necessary for the operation of the airplane when the optional Ice Protection System is installed in accordance with FAA Approved Piper data.

SECTION 2 - LIMITATIONS

- (a) The ice protection system was designed and tested for operation in the meteorological conditions of FAR 25, Appendix C, for continuous maximum and intermittent maximum icing conditions. **The ice protection system was not designed or tested for flight in freezing rain and/or mixed conditions or for icing conditions more severe than those of FAR 25, Appendix C. Therefore, flight in those conditions may exceed the capabilities of the ice protection system.**
- (b) Equipment required for flight into known or forecast icing:
- (1) Pneumatic wing and empennage boots.
 - (2) Wing ice detection light.
 - (3) Electrothermal propeller deice pads on the propeller blades.
 - (4) Electrothermal windshield panel.
 - (5) Heated lift detector.
 - (6) Heated pitot head.
 - (7) Dual alternators.
 - (8) Dual vacuum pumps.
 - (9) Alternate static source.
 - (10) All equipment required for night IFR flight.
- (c) If all the equipment listed is not installed and operative, the following placard must be installed in full view of the pilot.

WARNING

This aircraft is not approved for flight in icing conditions.

SECTION 3 - EMERGENCY PROCEDURES

WARNING

The malfunction of any required deice equipment requires immediate action to exit icing conditions. Depending on the severity of the icing encounter, failure to take immediate positive action can lead to performance losses severe enough to make level flight impossible. Therefore, upon verification of a system malfunction or failure, climb or descend out of icing conditions if this provides the shortest route. If exit must be made in level flight, consider the use of maximum power and exit by the most direct route. The effect of the additional fuel burned at higher power settings on aircraft range must be considered and an alternate airport chosen if necessary.

ALTERNATOR FAILURE IN ICING CONDITIONS (ALTERNATOR annunciator light illuminated)

Verify failureobserve ammeter for
both alternators
Electrical loadsreduce below 60 amps
A/V (volt/ammeter) switchcycle while observing
ammeter to determine
affected alternator

ALTNR circuit breaker
(affected alternator)check
ALTR switch (affected alternator).....OFF (for 1 second),
then ON

If unable to restore alternator:
ALTR switch (affected alternator)OFF

Either alternator will supply sufficient current for all required deice equipment and avionics. Other equipment may be turned on but in no case may the total load exceed 60 amps. The cabin recycle blowers and the strobe position and landing lights draw considerable current and should be turned off unless required. Immediate action should be taken to exit icing conditions.

VACUUM PUMP FAILURE IN ICING CONDITIONS (Suction below 4.8 in. Hg.)

Verify failureleft side red flow button
on suction gauge visible

STANDBY VAC PUMP switchON

The standby vacuum pump has sufficient capacity to operate the deice boots and flight instruments in a normal manner. Immediate action should be taken to exit icing conditions.

PROP HEAT SYSTEM MALFUNCTION

Excessive vibration may be an indication that the propeller heat is not functioning properly.

Prop controlexercise

Prop heat ammetercheck for proper indications:
(a) ON (needle in green arc)
for approx. 90 seconds
(b) OFF for approx. 90 seconds

A reading below the green arc during the ON cycle is an indication that the propeller blades may not be deicing properly.

PROP HEAT switchOFF if failure is indicated

WARNING

It is imperative that the PROP HEAT switch be turned OFF if vibration persists. This can be a symptom of uneven blade deicing which can lead to propeller unbalance and engine failure.

Immediate action should be taken to exit icing conditions.

SURFACE DEICE MALFUNCTION

If surface deice annunciator light remains illuminated more than 30 seconds, pull the surface deice circuit breaker. Immediate action should be taken to exit icing conditions.

SECTION 4 - NORMAL PROCEDURES

The Piper Malibu is approved for flight into known icing conditions when equipped with the complete Piper Ice Protection System. Operating in icing conditions of Continuous Maximum and Intermittent Maximum as defined in FAR 25, Appendix C has been substantiated; however, there is no correlation between these conditions and forecasts of reported "Light, Moderate and Severe" conditions. **Flight into severe icing is not approved.**

Icing conditions can exist in any clouds when the temperature is below freezing; therefore it is necessary to closely monitor outside air temperature when flying in clouds or precipitation. Clouds which are dark and have sharply defined edges usually have high water content and should be avoided whenever possible. **Freezing rain must always be avoided.**

Pneumatic boots must be cleaned regularly for proper operation in icing. The exterior surfaces of the aircraft should be checked prior to flight. **Do not attempt flight with frost, ice or snow adhering to the exterior surfaces of the aircraft or landing gear.**

Prior to dispatch into forecast icing conditions all ice protection equipment should be functionally checked for proper operation.

PREFLIGHT

- (a) An operational check of the heated windshield panel is accomplished by turning the W SHLD HEAT switch ON for a period not exceeding 30 seconds. Proper operation is indicated by the heated panel being warm to the touch.

NOTE

A safety feature prevents activation of the panel at ambient temperatures above approximately 75°F. In this case an operational check must be performed in flight by turning the W SHLD HEAT switch ON and observing the ammeter for an increase in load.

- (b) A check of the heated propeller should be performed by turning the PROP HEAT switch ON and feeling the deice pads. The pads should become warm to the touch.

CAUTION

Care should be taken when an operational check of the heated pitot head and heated lift detector is being performed. The units become very hot.

- (c) A check of the heated pitot head and lift detector should be performed by turning the S. WRN HEAT and PITOT HEAT switches ON and touching the units.
- (d) The surface boots should be checked prior to flight for damage and cleanliness. If necessary, damage should be repaired and boots cleaned prior to flight. An operational check of the boot system should be performed during engine run-up at 2000 RPM as follows:
 - (1) Actuate the momentary SURF DEICE switch - the boots will inflate through three phases: empennage, lower wing and upper wing with a duration of approximately six seconds per phase. The surface boot system then remains off until the switch is activated again. A green SURFACE DEICE annunciator light will remain on for approximately eighteen seconds.
 - (2) Visually check to insure that the boots have fully deflated to indicate proper operation of the vacuum portion of the pneumatic boot pump system.
- (e) The dual alternators should be checked by cycling the A/V (volt/ammeter) switch and observing for indication of output from both alternators on the ammeter.
- (f) The standby vacuum pump should be checked during engine run-up by turning the STANDBY VAC PUMP switch ON and observing that the right side red flow button on the gyro suction gauge disappears.

INFLIGHT

Icing conditions of any kind should be avoided whenever possible, since any minor malfunction which may occur is potentially more serious in icing conditions. Continuous attention of the pilot is required to monitor the rate of ice build-up in order to effect the boot cycle at the optimum time. Boots should be cycled when ice has built to between 1/4 and 1/2 inch thickness on the leading edge to assure proper ice removal. Repeated boot cycles at less

than 1/4 inch can cause a cavity to form under the ice and prevent removal; boot cycles at thicknesses greater than 1/2 inch may also fail to remove ice.

- Before entering probable icing conditions use the following procedures:
- (a) INDUCTION AIR.....ALTERNATE
 - (b) PITOT HEAT switch.....ON
 - (c) S. WRN HEAT switch.....ON
 - (d) WSHLD HEAT switch.....ON
 - (e) PROP HEAT switch.....ON
 - (f) DEFROST knob.....OUT
 - (g) VENT/DEFOG switch.....ON, if additional defrost is desired
 - (h) SURF DEICE switch.....activate after 1/4 to 1/2 inch accumulation
 - (i) Relieve propeller unbalance (if required) by exercising propeller control briefly. Repeat as required.

NOTE

For accurate magnetic compass readings, turn the WSHLD HEAT, PROP HEAT and PITOT HEAT switches OFF momentarily.

WARNINGS

Do not cycle surface boots with less than 1/4 inch of ice accumulation. Operation of boots with less than 1/4 inch of ice accumulation can result in failure to remove ice. Do not hold the momentary SURF DEICE switch on.

Elevator movement should be periodically checked prior to the first surface boot inflation in order to prevent an ice cap from forming between the elevator and stabilizer.

CAUTION

Operation of the pneumatic deice system is not recommended in temperatures below -40°C. Such operation may result in damage to the deicer boots.

The aircraft ammeter should be monitored whenever the deice equipment is in use. Excessive ammeter indications show excessive electrical load, which may cause a battery discharging condition that could eventually lead to battery depletion. Non-essential electrical equipment should be turned off to correct or prevent this condition.

When ice has accumulated on the unprotected surfaces of the airplane, aerodynamic buffet commences 5 to 10 knots before the stall. A substantial margin of airspeed should be maintained above the normal stall speed, since the stall speed will increase in prolonged icing encounters. For the same reason stall warning devices are not accurate and should not be relied upon.

If ice is remaining on the unprotected surfaces of the airplane at the termination of the flight, the landing can be made using full flaps and carrying a slight amount of power whenever practical. If ice removal from the protected surfaces cannot be accomplished (ie. due to a failure of the surface deice system) prior to the approach, the flaps must be left in the full up position. Approach speeds should be increased by 10 to 15 knots. Allow for increased landing distance due to the higher approach speeds.

CAUTION

If cruise airspeed drops below 130 knots in icing conditions increase power to maintain 130 knots. If maximum continuous power is required to maintain 130 knots immediate action should be taken to exit icing conditions.

NOTE

An icing encounter can render the aircraft radar unreliable due to beam reflection off of the ice layer on the radome. Also there may be a degradation of communication and navigation equipment due to ice accumulation on antennas.

SECTION 5 - PERFORMANCE

Climb speed should be increased to 130 knots when icing conditions are encountered during climb.

Cruise speeds are reduced approximately 5 knots when the surface boots are installed.

CAUTION

Ice accumulation on the unprotected surfaces can result in significant performance loss. During cruise, loss of airspeed can be as much as 30 knots or more.

NOTE

When icing conditions are encountered, loss of cruise airspeed and increased fuel flow resulting from higher than normal power settings to maintain altitude will reduce the aircraft range significantly. The use of an alternate airport should be considered if fuel quantity appears marginal.

CAUTION

If cruise airspeed drops below 130 knots in icing conditions increase power to maintain 130 knots. If maximum continuous power is required to maintain 130 knots immediate action should be taken to exit icing conditions.

NOTE

For additional general information on inflight icing refer to FAA Advisory Circular 91-51, Airplane Deice and Anti-ice Systems.

SECTION 6 - WEIGHT AND BALANCE

Factory installed optional equipment is included in the licensed weight and balance data in Section 6 of the Airplane Flight Manual.

SECTION 7 - DESCRIPTION AND OPERATION OF THE ICE PROTECTION SYSTEM AND EQUIPMENT

For flight into known icing conditions (FIKI), a complete ice protection system is required on the Malibu.

The complete ice protection system consists of the following components: Pneumatic wing and empennage boots, wing ice detection light, electrothermal propeller deice pads, electrothermal windshield panel, heated lift detector(s), heated pitot head, dual alternators, dual vacuum pumps and the alternate static source. Alternator and vacuum pump controls are located on the main switch panel on the left side of the instrument panel. Controls for the ice protection components are located to the right of the control quadrant on the deice switch panel (Figure 7-1).

A single component or a combination of components may be installed. However, the warning placard specified in Section 2 of this supplement is required when the complete system is not installed. Such a placard is also required if any component is inoperative.

The aircraft is designed to allow operation in the meteorological conditions of the FAR 25 envelopes for continuous maximum and intermittent maximum icing. **The airplane is not designed to operate for an indefinite period of time in every icing condition encountered in nature.** Activation of the ice protection system prior to entering icing conditions and attempting to minimize the length of the icing encounter will contribute significantly to the ice flying capabilities of the airplane.

WING AND EMPENNAGE BOOTS

Pneumatic deice boots are installed on the leading edges of the wing, the vertical stabilizer and the horizontal stabilizer. During normal operation, when the surface deice system is turned off, the engine driven vacuum pump applies a constant suction to the boots to provide smooth, streamlined leading edges. The boots are inflated by a momentary ON type SURF DEICE switch (Figure 7-1) located on the deice switch panel. Actuation of the SURF DEICE switch activates a pressure regulator valve which energizes three (tail, lower wing & upper wing) deice flow valves for approximately six seconds. The boot solenoid valves are activated and air pressure is released to the boots, sequentially inflating the surface deicers. A SURFACE DEICE indicator light, located on the annunciator panel illuminates when the boots inflate. When the cycle is complete, the deicer solenoid valves permit automatic overboard exhaustion of pressurized air. Suction is then reapplied to the boots.

Circuit protection for the surface deice system is provided by a SURF DEICE circuit breaker located on the circuit breaker panel.

WING ICE DETECTION LIGHT

Wing icing conditions may be detected during night flight by use of an ice detection light installed on the left side of the forward fuselage. The light is controlled by an ICE LIGHT switch (Figure 7-1) located on the deice switch panel. Circuit protection is provided by an ICE circuit breaker located in the LIGHT section of the circuit breaker panel.

ELECTRIC PROPELLER DEICE

Electrothermal propeller deice pads are bonded to a portion of the leading edges of the propeller blades. The system is controlled by an ON-OFF type PROP HEAT switch (Figure 7-1) located on the deice switch panel. Power for the propeller deicers is supplied by the aircraft electrical system through a PROP HEAT circuit breaker on the circuit breaker panel. When the PROP HEAT switch is actuated, power is applied to a timer through the PROP HEAT ammeter which monitors the current through the propeller deice system.

Power from the timer is cycled to brush assemblies which distribute power to slip rings. The current is then supplied from the slip rings directly to the electrothermal propeller deice pads.

The Hartzell propeller is deiced in a cycle which applies power to the deice pads for approximately 90 seconds and then shuts off for approximately 90 seconds. Once begun, cycling will proceed in the above sequence and will continue until the system is turned off. The PROP HEAT ammeter should indicate within the green shaded area during the portion of the cycle when power is being applied. This indicates proper operation of the system.

The propeller designation is: BHC-C2YF-1BF/F8052-0.

The heat provided by the deice pads reduces the adhesion between the ice and the propeller so that centrifugal force and the blast of the airstream cause the ice to be thrown off the propeller blades in small pieces.

ELECTRIC WINDSHIELD PANEL

An electrically heated windshield panel is installed on the exterior of the pilot's windshield. The panel is heated by current from the aircraft electrical system and controlled by an ON-OFF type W SHLD HEAT switch located on the deice switch panel.

The panel is equipped with a temperature sensing device which automatically turns the panel on and off during operation to maintain the desired operating characteristics. This feature also prevents activation of the panel at ambient temperatures above approximately 75°F. With ambient temperatures above 75°F an operational check must be performed in flight after the temperature has decreased. The ammeter must be observed for an increase in load when the W SHLD HEAT switch is activated to indicate proper operation of the panel.

HEATED LIFT DETECTOR

A heated lift detector is installed on the left wing. It is controlled by a S. WRN HEAT switch located on the deice switch panel and is protected by a S. WARN HEAT circuit breaker located on the ice protection circuit breaker panel. The lift detector has an in-line resistor activated by the main gear squat switch which limits the ground electrical load to approximately 33 percent of the inflight load. This allows the lift detector to be ground checked and activated prior to flight without damaging the unit.

HEATED PITOT HEAD

A heated AN type head is installed under the left wing. It is controlled by an ON-OFF type PITOT HEAT switch located on the deice switch panel and is protected by a PITOT HEAT circuit breaker located on the ice protection circuit breaker panel.

CAUTION

Care should be taken when an operational check of the heated pitot head is being performed on the ground. The unit becomes very hot.

DUAL ALTERNATORS

Dual 28 volt, 60 amp alternators are installed as part of the complete icing package. Both alternators must be operational for flight in icing conditions. They are controlled by ON-OFF type switches labeled ALTR NO 1 and ALTR NO 2 located on the main switch panel (Figure 7-2). Circuit protection is provided by similarly labeled circuit breakers located on the circuit breaker panel. During normal operation both alternators must be turned ON and the system is designed so that the alternators will share the total load equally. If either ALTR switch is turned OFF the ALTERNATOR annunciator light will remain lit.

DUAL VACUUM PUMPS

Dual vacuum pumps are installed as part of the complete icing package. The primary pump is engine driven and operates continuously when the engine is running. The standby pump is engine driven through an electrically actuated clutch and is activated either by turning ON the STANDBY VAC PUMP switch located on the main switch panel (Figure 7-2) or by depressing the SURF DEICE switch to activate the deice boots, in which case the standby pump is automatically actuated to increase the efficiency of the surface deice system. Either pump is capable of operating the surface deice system with the other pump inoperative. Therefore, the STANDBY VAC PUMP switch should only be actuated when a primary pump failure is indicated by illumination of the VACUUM LOW annunciator light and the appearance of the left side red flow button on the gyro suction gauge.

ALTERNATE STATIC SOURCE

An alternate static source control valve is located below the instrument panel to the left of the pilot. For normal operation, the lever remains down. To select alternate static source, place the lever in the up position. When the alternate static source is selected the airspeed and altimeter and vertical speed indicator are vented to the alternate static pad on the bottom aft fuselage. During alternate static source operation, these instruments may give slightly different readings. The pilot can determine the effects of the alternate sources at different airspeeds. Static source pads have been demonstrated to be non-icing; however, in the event icing does occur, selecting the alternate static source will alleviate the problem.

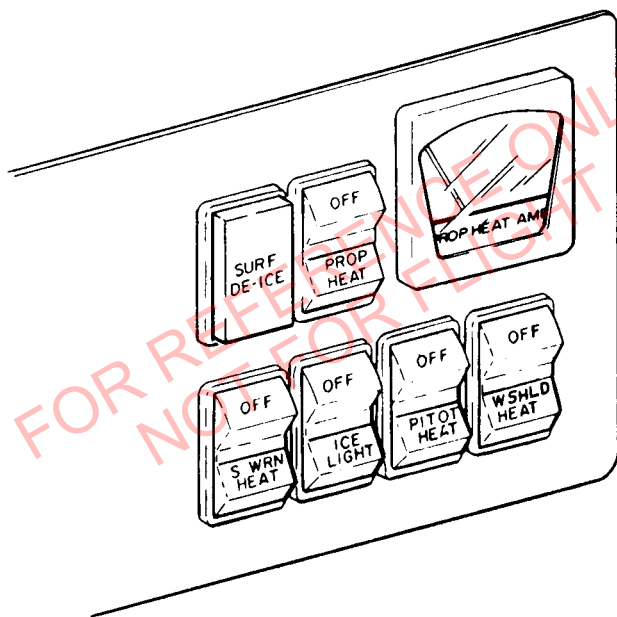

DEICE SWITCH PANEL

Figure 7-1

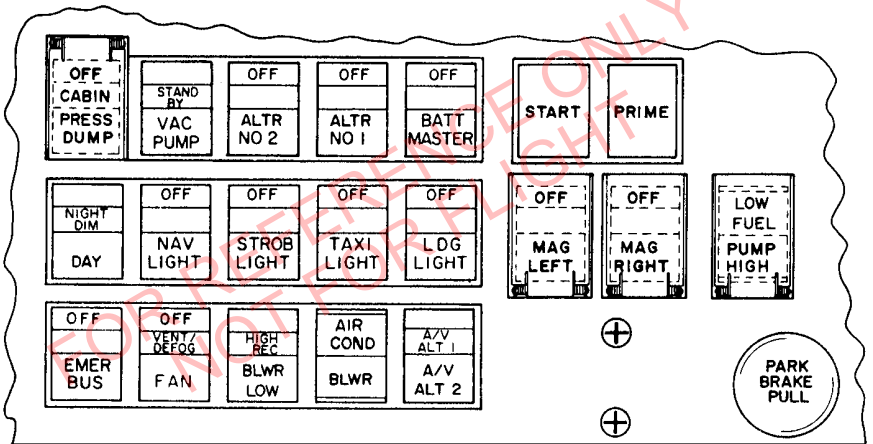

MAIN SWITCH PANEL

Figure 7-2

**PILOT'S OPERATING HANDBOOK
AND
FAA APPROVED AIRPLANE FLIGHT MANUAL
SUPPLEMENT NO. 11
FOR
3M (RYAN) STORMSCOPE, WX-11**

This supplement must be attached to the Pilot's Operating Handbook and FAA Approved Airplane Flight Manual when the optional WX-11 Stormscope system is installed per Piper Dwg. 84634-3. The information contained herein supplements or supersedes the information in the basic Pilot's Operating Handbook and FAA Approved Airplane Flight Manual only in those areas listed herein. For limitations, procedures and performance information not contained in this supplement, consult the basic Pilot's Operating Handbook and FAA Approved Airplane Flight Manual.

FAA APPROVED



D. H. TROMPLER
D.O.A. NO. SO.-1
PIPER AIRCRAFT CORPORATION
VERO BEACH, FLORIDA

DATE OF APPROVAL June 5, 1987

SECTION 1 - GENERAL

This supplement supplies information necessary for the operation of the airplane when the optional WX-11 Stormscope system is installed in accordance with FAA Approved Piper data.

SECTION 2 - LIMITATIONS

- (a) The WX-11 Stormscope system signal displays are not intended for the purpose of penetrating thunderstorm areas or areas of severe turbulence; such intentional use is not approved.

NOTE

Range selector determines receiver sensitivity and therefore relative range. Displayed range is based on signal strength and is not to be used for accurate determination of thunderstorm location.

- (b) Allow 30 seconds warm-up time before activating test functions.
- (c) Placards

Located on the top of the throttle quadrant near the Stormscope:

**STORMSCOPE NOT TO BE USED FOR
THUNDERSTORM AREA PENETRATION**

SECTION 3 - EMERGENCY PROCEDURES

No change.

SECTION 4 - NORMAL PROCEDURES

The 3M (Ryan) Stormscope, WX-11 Owners Manual, should be read thoroughly by the operator before using the displayed data to interpret thunderstorm activities.

(a) Operation (Pre-Flight)

- (1) Turn power/mode switch to ON.
- (2) Turn WX-11 to FWD, if desired, to concentrate system memory to forward 180° reception.
- (3) Push test button (TST). Check for proper signal reception on the 45° bearing. Check that signal reception occurs at both 100 NM range and 200 NM scale selections. No signal will normally be seen on the 50/25 NM scales.
- (4) Push clear button (CLR) to clear dots from screen so new thunderstorm data can be displayed.
- (5) Turn Range-Selection switch to desired range in nautical miles.
- (6) For night operation, the brightness control (BRT) controls intensity of dots for comfortable viewing.
- (7) Gyro Status. Depress TST and CLR. Hold both down to ensure gyro inputs are being used for stabilization.

If GYRO ON appears on the Model WX-11 Display, the dot pattern indicating thunderstorm activity will automatically turn relative to the aircraft heading as the aircraft turns.

If GYRO OFF appears on the display, the dot pattern will remain stationary as the aircraft heading changes. In this case, it will be necessary to clear the display manually by pushing the CLR button each time the heading is changed.

Gyro status can be changed from GYRO ON to GYRO OFF or vice versa by simply holding down both the TST and CLR buttons for three seconds or more.

NOTE

Operator should be aware that occasional aircraft electrical system (pitot heat, radio transmissions, etc.) activations or noisy external electrical devices in close ground proximity may cause signal patterns to be displayed. Such signals should be disregarded and cleared by the CLR button.

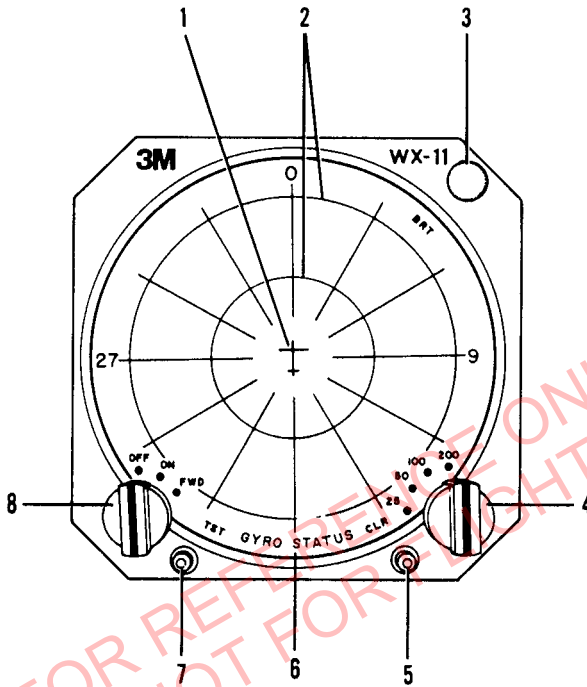

1. MAPPING DIRECTION INDICATOR
2. MAPPING LINES
3. BRIGHTNESS CONTROL
4. RANGE SELECTOR SWITCH
5. CLEAR BUTTON
6. GYRO STATUS
7. TEST BUTTON
8. POWER MODE SWITCH

WX-11 STORMSCOPE

Figure 4-1

(b) IN-FLIGHT FUNCTIONS

- (1) The WX-11 has the capacity to show up to 256 dots on the display screen. When in FWD mode all dots will be concentrated on the upper half of the screen to give greater definition of thunderstorm activity ahead of the airplane. No warnings will be received from the rear half of the display.
- (2) The size and shape of the cluster of dots will indicate how concentrated or sparse the electrical discharges are at the thunderstorm location.

The rapidity at which the individual dots appear indicate the rate of occurrence of the electrical discharges and generally the thunderstorm severity.

The dot patterns will update automatically anywhere from approximately 10 seconds to 5 minutes depending upon the nature and severity of the detected disturbances by automatic erasure of oldest signals and display of newly detected signals. A random, scattered display of signals may only indicate possible areas of atmospheric instability rather than significant thunderstorm activity.

Read the owners manual for complete explanation and interpretation of dots.

- (3) The push test button, TST, may be used in-flight to verify proper operation of the system.

SECTION 5 - PERFORMANCE

No change.

SECTION 6 - WEIGHT AND BALANCE

Factory installed optional equipment is included in the licensed weight and balance data in Section 6 of the Pilot's Operating Handbook.

SECTION 7 - DESCRIPTION AND OPERATION

The 3M (Ryan) Stormscope, WX-11, weather mapping system provides a visual screen readout of the electrical discharges associated with thunderstorms. This information with proper interpretation, will allow the pilot to detect severe thunderstorm activity. A series of green dots will be displayed on the screen to indicate the electrical discharge areas. The display scope provides full scale selectable ranges of 200, 100, 50 and 25 nautical miles along with 30° azimuth sectors.

FOR REFERENCE ONLY
NOT FOR FLIGHT

**PILOT'S OPERATING HANDBOOK
AND
FAA APPROVED AIRPLANE FLIGHT MANUAL
SUPPLEMENT NO. 12
FOR
ARNAV R-30 LORAN C NAVIGATOR &
RS08 SERIES REMOTE SWITCH
WITH KAP/KFC 150 AUTOPILOT SYSTEM**

This supplement must be attached to the Pilot's Operating Handbook and FAA Approved Airplane Flight Manual when the optional ARNAV R-30 Loran C Navigator is installed per the Equipment List. The information contained herein supplements or supersedes the basic Pilot's Operating Handbook and FAA Approved Airplane Flight Manual only in those areas listed herein. For limitations, procedures and performance information not contained in this supplement, consult the basic Pilot's Operating Handbook and FAA Approved Airplane Flight Manual.

FAA APPROVED



D. H. TROMPLER
D.O.A. NO. SO.-1
PIPER AIRCRAFT CORPORATION
VERO BEACH, FLORIDA

DATE OF APPROVAL June 5, 1987

SECTION 1 - GENERAL

This supplement supplies information necessary for the operation of the airplane when the optional ARNAV R-30 Loran C Navigator System and RS08 Series Remote Switch are installed. The navigator system must be operated within the limitations herein specified. The information contained within this supplement is to be used in conjunction with the complete handbook.

This supplement has been FAA Approved as a permanent part of this handbook and must remain in this handbook at all times when the ARNAV R-30 Loran C Navigator System is installed.

SECTION 2 - LIMITATIONS

- (a) The ARNAV R-30 Loran C Navigator Operation Manual (P/N 570-0093, latest revision) must be immediately available to the flight crew whenever navigation is predicted on the use of the ARNAV R-30.
- (b) The ARNAV R-30 Loran C Navigator is not approved for IFR approaches.
- (c) During operation no flight operation shall be predicted upon the ARNAV R-30 Loran C Navigator whenever a NAV flag is displayed by the CDI or ARNAV R-30 Display.

SECTION 3 - EMERGENCY PROCEDURES

No changes to the basic Emergency Procedures provided by Section 3 of this Pilot's Operating Handbook are necessary for this supplement.

SECTION 4 - NORMAL PROCEDURES

- (a) OPERATION

Normal operating procedures are outlined in the ARNAV R-30 Loran C Navigator Operation Manual (P/N 570-0093, latest revision).

(b) NAV-COUPLED MODE

When operating the KAP/KFC 150 flight control system in either the navigation (NAV) or approach (APR) mode and the NAV/LORAN switch has been set to the ARNAV R-30 as the navigation source, all operational procedures which are applicable to these two modes, as described in the KAP/KFC 150 Operator's Manual and Flight Manual Supplement, still apply, with the following notations or exceptions:

- (1) ARNAV R-30 is not approved for IFR approaches.
- (2) Course deviation data for the autopilot is derived from the ARNAV R-30.
- (3) For course intercept or course tracking, set the HSI course needle to the Loran C course to be flown. This setting provides course datum to the autopilot.
- (4) Autopilot Nav Select Switch Positions:

NAV/LORAN SW	A/P NAV 1 NAV 2 A/P SW	Selections	VHF/LORAN ANNUNCIATOR
NAV.	A/P NAV 1	NAV 1 coupled to A/P Displayed on H.S.I.	VHF ANNUNCIATOR ON
NAV.	A/P NAV 2	NAV 2 coupled to A/P displayed on NAV 2 indicator	VHF ANNUNCIATOR ON
LORAN	*	LORAN coupled to A/P displayed on H.S.I.	LORAN ANNUNCIATOR ON
*When the NAV/LORAN switch is in the Loran mode the A/P NAV 1/NAV 2 A/P autopilot coupling switch is inactive.			

(c) NAVIGATION DISPLAYS

The Loran C System drives the pilot's HSI display when manually selected by the NAV/LORAN switch. This configuration is annunciated by a VHF/LORAN mode light on the pilot's instrument panel. The HSI will only display left or right course information, to/from flags, and a NAV flag indication from the ARNAV R-30. The course selector pointer must be manually set to the Loran C course. (Actual course cannot be determined on the HSI by rotating the course selector pointer).

When Loran has been selected for display on the HSI, the bearing pointer will continue displaying the bearing to a previous selected VOR or RNAV waypoint or NDB. Caution must be used in noting that the pointer will not indicate the bearing to the Loran waypoint.

(d) RS08 REMOTE SWITCH OPERATION

The RS08 provides remote switching of navigation and Loran signals to allow two systems to share a common indicator. The command for this transfer comes from the NAV/LORAN select switch and the active system is annunciated by the VHF/LORAN annunciator located on the pilot's instrument panel above the airspeed indicator. A bright-dim toggle switch is provided to allow dimming of the annunciation.

If the NAV receiver is channeled to an ILS station while in the LORAN mode, the RS08 will automatically return the system to the VOR/ILS mode, irrespective of any other command. Care should be taken to not preset any such station while navigating enroute by Loran, or the presentation will be switched back to the NAV system.

If power is lost to the RS08, both annunciators will be dark, and the system will automatically return to the VOR/ILS display. The pilot should confirm correct data display by channeling the radio in question, or offsetting the radial, and checking for the correct presentation.

If there is an internal failure in the RS08 which causes loss of power to the relays, driver, or logic failure, it will appear

as one of three presentations:

- (1) The VHF/LORAN annunciator stays lit in one mode or the other, and will not transfer. Only one NAV source will be available until the system is repaired. This can also be caused by external switch failure.
- (2) No annunciator will light. Lamps check OK. Indicates relay failure. Do not use any navigation data, as data is likely faulty. Repair immediately.
- (3) Unit will transfer, but only one annunciator will light. Lamps check OK. Indicates relay or wiring failure, and will probably give valid data only if the lamp lights in the VOR/ILS mode. Confirm data by pilot test, and repair immediately.

In general, the pilot should always confirm that the presentation seen is, in fact, tied to the system that has been selected. A simple radial offset or other method will greatly improve operational safety and insure that a power failure, ILS channeled NAV, or other fault has not presented false navigation data on the HSI/CDI.

(e) **WAYPOINT ALERT ANNUNCIATOR**

Becomes active within a 2 nm radius of the selected waypoint.

SECTION 5 - PERFORMANCE

Installation of the ARNAV R-30 Loran C Navigator with RS08 series remote switch does not affect the basic performance information presented in Section 5 of this Pilot's Operating Handbook.

SECTION 6 - WEIGHT AND BALANCE

Factory installed optional equipment is included in the licensed weight and balance data in Section 6 of the Pilot's Operating Handbook.

**PILOT'S OPERATING HANDBOOK
AND
FAA APPROVED AIRPLANE FLIGHT MANUAL
SUPPLEMENT NO. 13
FOR
NORTHSTAR M1 LORAN C NAVIGATOR
WITH KAP/KFC 150 AUTOPILOT SYSTEM**

This supplement must be attached to the Pilot's Operating Handbook and FAA Approved Airplane Flight Manual when the optional Northstar M1 Loran C Navigator is installed per the Equipment List. The information contained herein supplements or supersedes the basic Pilot's Operating Handbook and FAA Approved Airplane Flight Manual only in those areas listed herein. For limitations, procedures and performance information not contained in this supplement, consult the basic Pilot's Operating Handbook and FAA Approved Airplane Flight Manual.

FAA APPROVED



D. H. TROMPLER
D.O.A. NO. SO.-1
PIPER AIRCRAFT CORPORATION
VERO BEACH, FLORIDA

DATE OF APPROVAL June 5, 1987

SECTION 1 - GENERAL

This supplement supplies information necessary for the operation of the airplane when the optional Northstar M1 Loran C Navigator System is installed. The navigator system must be operated within the limitations herein specified. The information contained within this supplement is to be used in conjunction with the complete handbook.

This supplement has been FAA Approved as a permanent part of this handbook and must remain in this handbook at all times when the Northstar M1 Loran C Navigator System is installed.

SECTION 2 - LIMITATIONS

- (a) Northstar M1 Loran C Navigator Reference Manual (latest revision) must be immediately available to the flight crew whenever navigation is predicated on the use of the Northstar M1.
- (b) The Northstar M1 Loran C Navigator is approved for VFR only.
- (c) During operation no flight operation shall be predicated upon the Northstar M1 Loran C Navigator whenever a NAV flag is displayed by the CDI.
- (d) The following placard is located on the pilot's instrument panel adjacent to the HSI.

LORAN C APPROVED FOR VFR ONLY

SECTION 3 - EMERGENCY PROCEDURES

No changes to the basic Emergency Procedures provided by Section 3 of this Pilot's Operating Handbook are necessary for this supplement.

SECTION 4 - NORMAL PROCEDURES

- (a) OPERATION

Normal operating procedures are outlined in the Northstar M1 Loran C Navigator Reference Manual (latest revision).

(b) NAV-COUPLED MODE

When operating the KAP/KFC 150 flight control system in either the navigation (NAV) or approach (APR) mode and the NAV/LORAN switch has been set to the Northstar M1 as the navigation source, all operational procedures which are applicable to these two modes, as described in the KAP/KFC 150 Operator's Manual and Flight Manual Supplement, still apply, with the following notations or exceptions:

- (1) Northstar M1 is approved for VFR only.
- (2) Course deviation data for the autopilot is derived from the Northstar M1.
- (3) For course intercept or course tracking, set the HSI course needle to the Loran C course to be flown. This setting provides course datum to the autopilot.
- (4) Switch Positions:

NAV/LORAN SW	A/P NAV 1 NAV 2 A/P SW	Selections
NAV	A/P NAV 1	NAV #1 coupled to A/P Displayed on H.S.I.
NAV	A/P NAV 2	NAV #2 coupled to A/P displayed on NAV #2 indicator
LORAN	*	LORAN coupled to A/P displayed on H.S.I. (Blue Indicator light)
*When the NAV/LORAN switch is in the Loran mode the A/P NAV 1/NAV 2 A/P autopilot coupling switch is inactive.		

(c) NAVIGATION DISPLAYS

The Loran C System drives the pilot's HSI display when manually selected by the NAV/LORAN switch. This configuration is annunciated by a mode light adjacent to the HSI. The HSI will only display left or right course information and a NAV flag indication from the Northstar M1. The course selector pointer must be manually set to the Loran C course. (Actual course cannot be determined on the HSI by rotating the course selector pointer).

When Loran has been selected for display on the HSI, the bearing pointer will continue displaying the bearing to a previous selected VOR or RNAV waypoint or NDB. Caution must be used in noting that the pointer will not indicate the bearing to the Loran waypoint.

(d) WAYPOINT ALERT ANNUNCIATOR

Becomes active within a one-minute radius of a waypoint.

(e) PARALLEL OFFSET ANNUNCIATOR

Becomes active whenever a parallel offset is in effect.

SECTION 5 - PERFORMANCE

Installation of the Northstar M1 Loran C Navigator does not affect the basic performance information presented in Section 5 of this Pilot's Operating Handbook.

SECTION 6 - WEIGHT AND BALANCE

Factory installed optional equipment is included in the licensed weight and balance data in Section 6 of the Pilot's Operating Handbook.

**PILOT'S OPERATING HANDBOOK
AND
FAA APPROVED AIRPLANE FLIGHT MANUAL
SUPPLEMENT NO. 14
FOR
SUPPLEMENTAL ELECTRIC HEATER**

This supplement must be attached to the Pilot's Operating Handbook and FAA Approved Airplane Flight Manual when the Supplemental Electrical Heater is installed per Piper Drawing 89124-2 or Piper Kit 765-348. The information contained herein supplements or supersedes the information in the basic Pilot's Operating Handbook and FAA Approved Airplane Flight Manual only in those areas listed herein. For limitations, procedures, and performance information not contained in this supplement, consult the basic Pilot's Operating Handbook and FAA Approved Airplane Flight Manual.

FAA APPROVED



D. H. TROMPLER
D.O.A. NO. SO.-1
PIPER AIRCRAFT CORPORATION
VERO BEACH, FLORIDA

DATE OF APPROVAL November 2, 1987

SECTION 1 - GENERAL

This supplement supplies information necessary for the operation of the airplane when the optional Supplemental Electric Heater is installed in accordance with FAA Approved Piper data.

SECTION 2 - LIMITATIONS

- (a) Dual functioning alternators are required.
- (b) A low voltage monitor system and annunciator must be installed and functional.
- (c) The Vent/Defog Fan must be operational for heater ground operation.
- (d) Maximum ambient temperature for heater operation is 20°C (68°F).

SECTION 3 - EMERGENCY PROCEDURES

ALTERNATOR annunciator light illuminated:

AUX CABIN HEAT SwitchOFF

LO BUS annunciator light illuminated:

Volt/Ammeter.....VERIFY LOW VOLTAGE
AUX CABIN HEAT Switch.....OFF
Electrical Load.....REDUCE until LO BUS
light EXTINGUISHES

NOTE

If the LO BUS annunciator light does not extinguish after the electrical load has been reduced, and low voltage is verified, an electrical failure is indicated. Refer to Electrical Failures procedure in the basic Pilot's Operating Handbook.

Heater Control Circuit Failure (Heater Continues to Operate With AUX CABIN and VENT/DEFOG FAN switches OFF):

VNT-DFG Circuit Breaker.....PULL

If the heater still operates:

BATT MASTER SwitchOFF
EMER BUS Switch.....ON
Land as soon as practical.

SECTION 4 - NORMAL PROCEDURES

AFTER ENGINE START

BATT MASTER Switch.....	ON
Alternator Switches	OFF
VENT/DEFOG FAN Switch	ON
Airflow.....	CHECK
Volt/Ammeter	LESS than 25 Vdc (increase electrical load as necessary to lower voltage)
LO BUS Annunciator.....	ILLUMINATED
Electrical Switches.....	OFF
VENT/DEFOG FAN Switch	OFF
Alternator Switches	ON

NOTE

Low voltage monitor system and annunciator must be checked operational before heater operation. VENT/DEFOG FAN must be checked operational before heater ground operation.

HEATER OPERATION

VENT/DEFOG FAN	ON
AUX CABIN HEAT Switch.....	ON

For maximum heat:

REC BLWR Switch	OFF
CABIN TEMP Control	FULL OUT
DEFROST Control	AS REQUIRED to CLEAR WINDSHIELD: then FULL IN

NOTE

This unit should be considered primarily as an auxiliary backup to the standard heating system. There is no external control over the heat produced by the unit.

SECTION 5 - PERFORMANCE

No change.

SECTION 6 - WEIGHT AND BALANCE

Factory installed optional equipment is included in the licensed weight and balance data in Section 6 of the Pilot's Operating Handbook.

For field installation of the Supplemental Electric Heater add 1.10 pounds at 120.5 inches aft of datum. Increase moment 133 inch-pounds.

SECTION 7 - DESCRIPTION AND OPERATION

The Supplemental Electric Heater (Heater) consists of a resistance type heat element, dual hermetically sealed bimetallic type overtemperature protection, power relay, fuse, and lighted on-off switch. The element is installed in the left bleed air duct forward of the pressure bulkhead downstream from the vent/defog fan. Both the heater switch and the vent/defog switch must be engaged to supply power to the heater element. The vent/defog fan can be operated independent of the heater by engaging just the vent/defog switch.

Both the heater control circuit and the vent/defog fan circuit utilize the 10 amp VNT-DFG circuit breaker located on the ENVIRONMENTAL circuit breaker panel. Heater element power is supplied from the battery master solenoid through the 35 amp heater fuse and the heater power relay. The 35 amp heater fuse is not accessible to the pilot. The electrical load imposed by the heater and the vent/defog fan is 40.35 amps. Installation is limited to aircraft equipped with dual alternators. Emergency interruption of the circuit can be accomplished by disengaging the battery master switch and engaging the emergency bus switch.

A low voltage monitor system is included with the Heater. This system alerts the pilot to a low bus voltage condition before the battery is discharged. The system consists of a low voltage monitor module located behind the instrument panel, and an annunciator light mounted above the clock on the pilot's instrument panel (refer to Figure 7-1).

The annunciator is the press to test type. The light lens is red with the words LO BUS marked on it in black. Power is supplied to the low voltage monitor system from the emergency bus through a 5 amp fuse. The LO BUS annunciator is activated when the bus voltage drops below 25.0 +/- 0.3 volts. When the bus voltage goes above the warning light activation point the LO BUS annunciator is extinguished. The annunciator is tested by pressing on the LO BUS warning light causing it to illuminate. LO BUS annunciator dimming is controlled by the day/night switch.

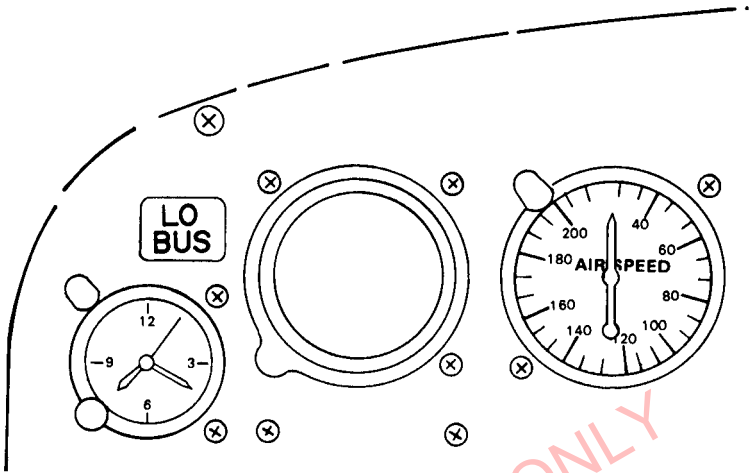

**LOW VOLTAGE MONITOR
 WARNING LIGHT INSTALLATION**

Figure 7-1

The electrical switch panel has been modified to accommodate the addition of the AUX CABIN HEAT switch (refer to Figure 7-2). Refer to Figure 7-3 for a schematic of the Electrical Heater and Voltage Monitor circuits.

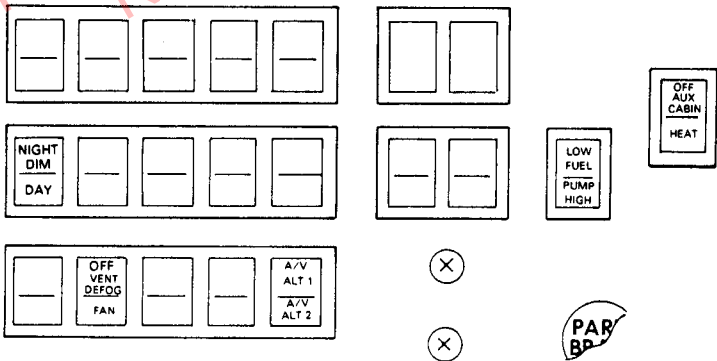

ELECTRICAL SWITCH PANEL MODIFICATION

Figure 7-2

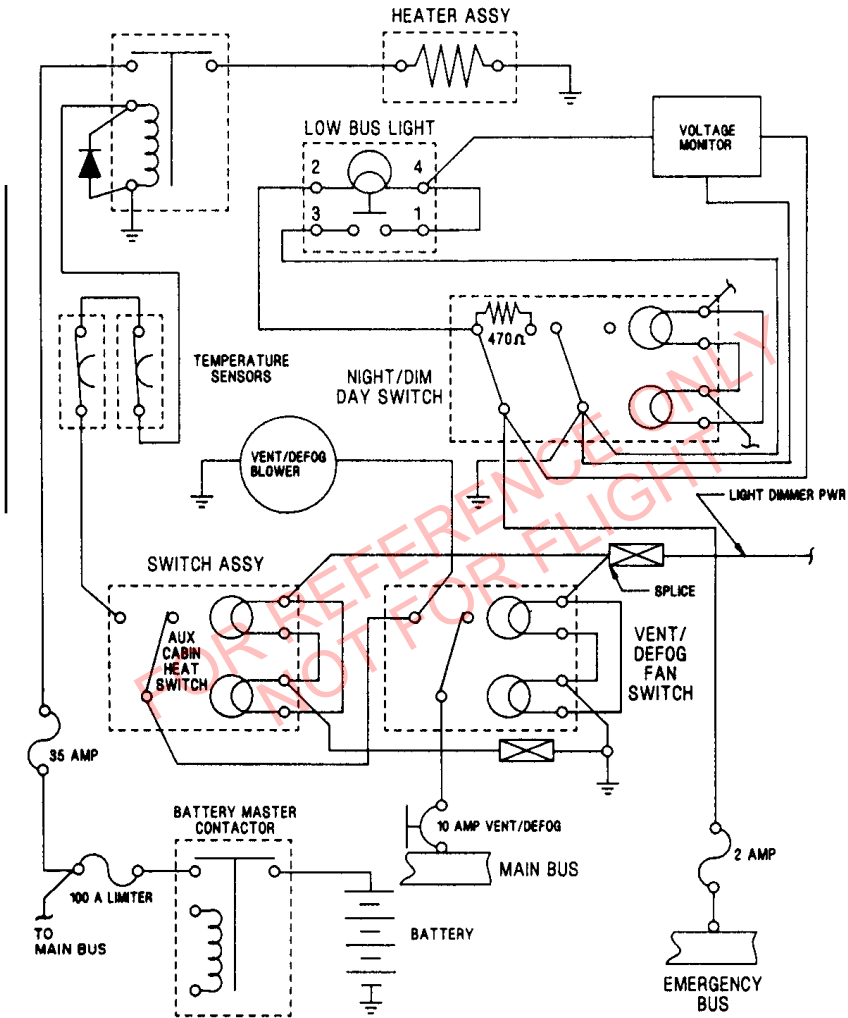

ELECTRIC HEAT AND LOW VOLTAGE MONITOR SCHEMATIC

Figure 7-3

**PILOT'S OPERATING HANDBOOK
AND
FAA APPROVED AIRPLANE FLIGHT MANUAL
SUPPLEMENT NO. 15
FOR
II MORROW, INC.,
APOLLO II, MODEL 612, LORAN C
NAVIGATION SYSTEM
WITH KAP/KFC 150 AUTOPILOT SYSTEM**

This supplement must be attached to the Pilot's Operating Handbook and FAA Approved Airplane Flight Manual when the optional II Morrow, Inc., Apollo II, Model 612, Loran C Navigator is installed per the Equipment List. The information contained herein supplements or supersedes the basic Pilot's Operating Handbook and FAA Approved Airplane Flight Manual only in those areas listed herein. For limitations, procedures and performance information not contained in this supplement, consult the basic Pilot's Operating Handbook and FAA Approved Airplane Flight Manual.

FAA APPROVED



D. H. TROMPLER
D.O.A. NO. SO.-1
PIPER AIRCRAFT CORPORATION
VERO BEACH, FLORIDA

DATE OF APPROVAL October 7, 1988

SECTION 1 - GENERAL

This supplement supplies information necessary for the operation of the airplane when the optional II Morrow, Inc., Apollo II, Model 612, Loran C Navigation System is installed. The navigation system must be operated within the limitations herein specified. The information contained within this supplement is to be used in conjunction with the complete handbook.

This supplement has been FAA Approved as a permanent part of this handbook and must remain in this handbook at all times when the Apollo II, Model 612, Loran C Navigation System is installed.

SECTION 2 - LIMITATIONS

- (a) II Morrow, Inc., Apollo II, Model 612, Loran C Navigation System, Pilot's Operating Handbook (P/N 560-0022B latest revision) must be immediately available to the flight crew whenever navigation is predicated on the use of the Apollo II.
- (b) The Apollo II, Loran C Navigation System is not approved for IFR approaches.
- (c) IFR RNAV operation is limited to the 48 contiguous states, and the District of Columbia. See Pilot's Operating Handbook P/N 560-0022B latest revision).
- (d) During RNAV operation of the Apollo II, Model 612 additional navigation equipment required for the specific type of operation must be installed and operable.
- (e) The Apollo II, Model 612 Loran C Navigation System must be checked for accuracy (reasonableness) prior to use as a means of navigation after acquisition of a new GRI, or re-acquisition of the same GRI.
- (f) During the Apollo II, Model 612 system start-up test the pilot must check the following items for proper operation prior to each IFR flight: External LORAN WARN annunciator, external LORAN VFR annunciator, CDI needle, and CDI flag. The pilot shall verify that all of the dots in the alpha-numeric displays are functioning. The pilot shall verify that both lamps are operational in the LORAN VFR and LORAN WARN external annunciators.

- (g) No flight operation shall be predicated on the use of the Apollo II, Model 612, Loran C Navigation System whenever a NAV OFF flag is displayed by the CDI. In addition, no IFR flight shall be predicated on the use of the Apollo II, Model 612, Loran C Navigation System whenever the external LORAN WARN or LORAN VFR annunciators are lighted, or the accuracy reasonableness check has a consistently greater position error than 3.0 nautical miles or any failure observed during the system start-up test.
- (h) The pilot must verify the coordinates of each waypoint to be used during an IFR flight, including those waypoints used from the FLYBRARY data base.
- (i) The Apollo II, Model 612 Loran C Navigation System may not be used for IFR flight, during icing conditions.
- (j) IFR operation is permitted only if, in the Software Version pages of the SETUP Mode, the following Operating System and Front Panel software versions appear:
- (1) OP 2.6 or 2.7
 - (2) FP 1.5
- (k) The following placard is located on the pilot's instrument panel adjacent to the HSI:
- LORAN C NOT APPROVED FOR APPROACH
- (l) If a GRI change is required while in flight, the following Caution should be noted:

CAUTION

When changing GRI in flight, expect to navigate DR for approximately 2 minutes waiting for acquisition of new GRI.

SECTION 3 - EMERGENCY PROCEDURES

No changes to the basic Emergency Procedures provided by Section 3 of this Pilot's Operating Handbook are necessary for this supplement.

SECTION 4 - NORMAL PROCEDURES

(a) OPERATION

Normal operating procedures are outlined in the II Morrow Inc., Apollo II, Loran C Pilot's Operating Handbook (P/N 560-0022B, latest revision.

(b) NAV-COUPLED MODE

When operating the KAP/KFC 150 Flight Control System in either the Navigation (NAV) or Approach (APR) Mode and the NAV/LORAN switch has been set to the Apollo II as the navigation source, all operational procedures which are applicable to these two modes, as described in the KAP/KFC 150 Operators Manual and Flight Manual Supplement, still apply, with the following notations or exceptions:

- (1) Apollo II, Model 612, Loran C is not approved for IFR approaches.
- (2) Course deviation data for the autopilot is derived from the Apollo II.
- (3) For course intercept or course tracking, set the HSI course needle to the Loran C course to be flown. This setting provides course datum to the autopilot.
- (4) Autopilot Nav Select Switch Positions:

NAV/LORAN SW	A/P NAV 1 NAV 2 A/P SW	Selections
NAV	A/P NAV 1	NAV #1 coupled to A/P Displayed on H.S.I.
NAV	A/P NAV 2	NAV #2 coupled to A/P displayed on NAV #2 indicator
LORAN	*	LORAN coupled to A/P displayed on H.S.I. (Blue Indicator light)
*When the NAV/LORAN switch is in the Loran mode the A/P NAV 1/NAV 2 A/P autopilot coupling switch is inactive.		

(c) NAVIGATION DISPLAYS

The Loran C System drives the pilot's HSI display when manually selected by the NAV/LORAN switch. This configuration is annunciated by a mode light adjacent to the HSI. The HSI will only display left or right course information, to/from flags and a Off/Warning flag indication from the Apollo II. The course selector pointer must be manually set to the Loran C course. (Actual course cannot be determined on the HSI by rotating the course selector pointer).

When Loran has been selected for display on the HSI, the bearing pointer will continue displaying the bearing to a previous selected VOR or RNAV waypoint or NDB. Caution must be used in noting that the pointer will not indicate the bearing to the Loran waypoint.

(d) External Annunciators

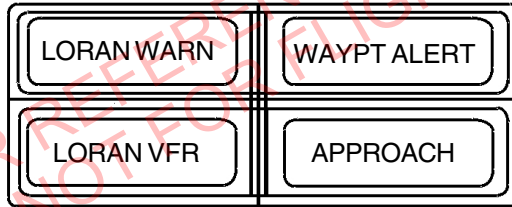

The Apollo II also provides status information to four externally mounted annunciators: LORAN WARN, WAYPT ALERT, LORAN VFR, and APPROACH.

LORAN WARN The LORAN WARN annunciator will light whenever the internal WARN annunciator lights. The LORAN is not usable for navigation.

WAYPT ALERT The WAYPT ALERT annunciator will light whenever the internal ARIV annunciator lights. You are nearing your destination.

LORAN VFR

When the LORAN VFR annunciator lights you may not use the APOLLO II for IFR navigation. This annunciator will light when the criteria for IFR navigation is not met.

The LORAN VFR annunciator may light while the LORAN WARN annunciator is not lighted. VFR navigation is still permitted.

The LORAN VFR annunciator will light due to the following reasons:

1. You have selected a course offset, ASF factors, Approach CDI resolution.
2. You have manually selected the triad or magnetic variation.
3. Accuracy does not meet IFR standards due to poor geometry, low signal, or high noise.

APPROACH

The APPROACH annunciator will light when the internal APP annunciator is lighted. Approach CDI resolution (1.25 nm full scale) has been selected.

SECTION 5 - PERFORMANCE

Installation of the Apollo II Loran C does not affect the basic performance information in Section 5 of this Pilot's Operating Handbook.

SECTION 6 - WEIGHT AND BALANCE

Factory installed optional equipment is included in the licensed weight and balance data in Section 6 of the Pilot's Operating Handbook.

**PILOT'S OPERATING HANDBOOK
AND
FAA APPROVED AIRPLANE FLIGHT MANUAL**

**SUPPLEMENT NO. 16
FOR
BENDIX/KING RDS 81/82/82VP
DIGITAL WEATHER RADAR**

This supplement must be attached to the Pilot's Operating Handbook and FAA Approved Airplane Flight Manual when the optional Bendix/King RDS 81/82/82VP Digital Weather Radar is installed per the Equipment List. The information contained herein supplements or supersedes the information in the basic Pilot's Operating Handbook and FAA Approved Airplane Flight Manual only in those areas listed herein. For limitations, procedures, and performance information not contained in this supplement, consult the basic Pilot's Operating Handbook and FAA Approved Airplane Flight Manual.

FAA APPROVED



**D. H. TROMPLER
D.O.A. NO. SO-1
PIPER AIRCRAFT CORPORATION
VERO BEACH, FLORIDA**

DATE OF APPROVAL May 14, 1990

SECTION 1 - GENERAL

This supplement supplies information necessary for the operation of the airplane when the optional Bendix/King RDS 81/82/82VP Digital Weather Radar is installed in accordance with FAA Approved Piper data.

SECTION 2 - LIMITATIONS

Do not operate the radar during refueling operations or within 15 feet of trucks or containers accommodating flammables or explosives. Do not allow personnel within 15 feet of area being scanned by antenna when system is transmitting.

SECTION 3 - EMERGENCY PROCEDURES

No changes to the basic Emergency Procedures provided by Section 3 of this Pilot's Operating Handbook are necessary for this supplement.

SECTION 4 - NORMAL PROCEDURES

WARNING

Do not operate the radar during refueling operations or within 15 feet of trucks or containers accommodating flammables or explosives. Do not allow personnel within 15 feet of area being scanned by antenna when system is transmitting.

Preflight and normal operating procedures are outlined in the Bendix/King RDS 81/82 Digital Weather Radar Pilot's Guide, P/N 006-08539-0001, latest revision, and in the Bendix/King RDS 82VP Vertical Profile Radar Pilot's Guide, P/N 006-08461-0000, latest revision.

When the range is set to 10 miles a small sector of return may be observed along the left side of the display . This is the reflection of the cowl and propeller and will diminish with increasing range. This anomaly is not significant at longer ranges and does not effect the operation or display of weather radar.

SECTION 5 - PERFORMANCE

When the radar pod is installed:

- a. The rate of climb is decreased approximately 50 fpm.
- b. The cruise speed is decreased approximately 2 knots.
- c. The cruise range is decreased approximately 1% due to the decrease in cruise speed.

SECTION 6 - WEIGHT AND BALANCE

Factory installed optional equipment is included in the licensed weight and balance data in Section 6 of the basic Pilot's Operating Handbook.

SECTION 7 - DESCRIPTION AND OPERATION

The RDS 81 system consists of the:

- a. RS 811A sensor which combines the system components of antenna, receiver, and transmitter.
- b. The IN 812A indicator (Figure 7-1) which incorporates all the operational controls.

The RDS 82 system consists of the:

- a. RS 181A sensor which combines the system components of antenna, receiver, and transmitter.
- b. The IN 182A indicator (Figure 7-3) which incorporates all the operational controls.

The RDS 82VP system consists of the:

- a. RS 181A VP sensor which combines the system components of antenna, receiver, and transmitter.
- b. The IN 182A VP indicator (Figure 7-5) which incorporates all the operational controls.

The system's antenna is installed inside a teardrop shaped pod mounted beneath the right wing just outboard of the wing jack point.

Operation and Controls

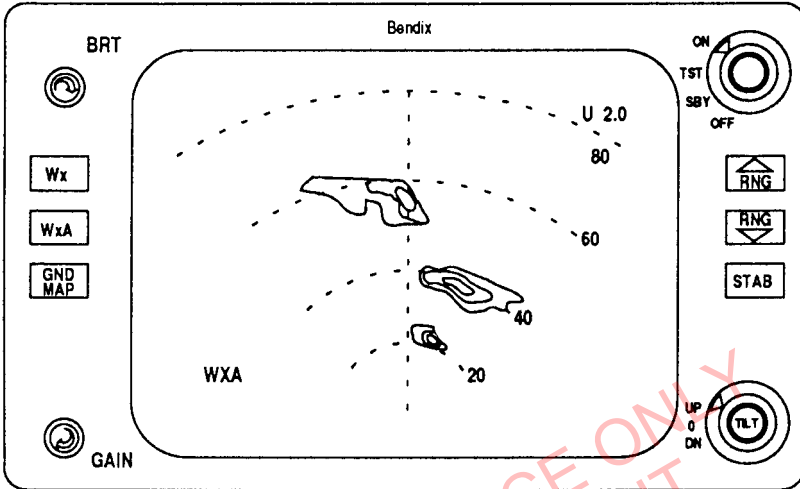

RDS 81 CONTROLS AND INDICATOR

Figure 7-1

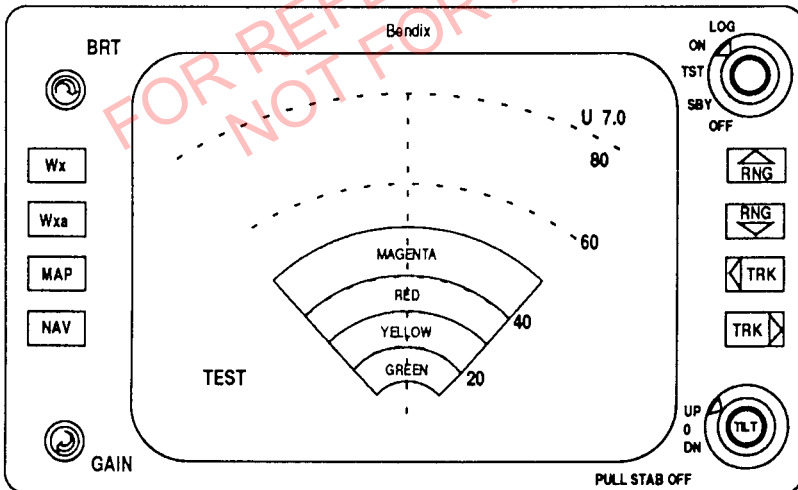

RDS 82 CONTROLS AND INDICATOR

(TEST PATTERN SHOWN)

Figure 7-3

Operation and Controls (cont.)

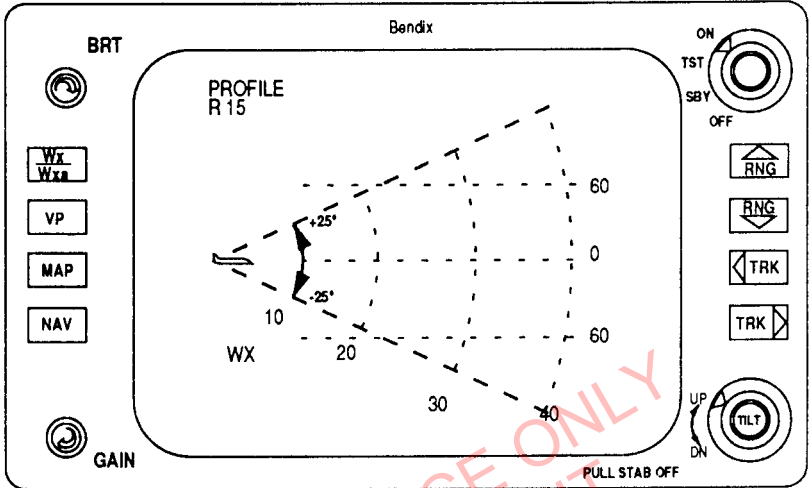

RDS 82VP CONTROLS AND INDICATOR

VP Mode

Figure 7-5

CONTROL/ DISPLAY	FUNCTION
BRT Control	Adjusts brightness of the display for varying cockpit light conditions.
Wx Button (RDS 81/82 Only)	When pressed selects the weather (Wx) mode. WX will appear on lower left of the display. Areas of high rainfall (more than 2 to 5 inches per hour) will appear in magenta color.
WxA Button (RDS 81/82 Only)	When pressed selects the weather-alert (Wxa) mode. WXA will appear in the lower left of the display. Magenta areas of storm flash between magenta and black.

Operation and Controls (cont.)

CONTROL/ DISPLAY	FUNCTION
<p>Wx/Wxa Button (RDS 82VP Only)</p>	<p>When pressed, alternately selects between the Wx (weather) and Wxa (weather alert) modes of operation. WX or WXA will appear in the lower left of the display. Areas of high rainfall appear in magenta color. When the Wxa mode is selected, magenta areas of storms flash between magenta and black.</p>
<p>VP Button (RDS 82VP Only)</p>	<p>When pressed, selects and deselects the vertical profile mode of operation. Selecting the VP mode (see Figure 7-7) of operation will not change the selected mode of operation: TST, Wx, Wxa, or GND MAP. Once in VP, these modes may be changed as desired. VP will engage from the NAV MAP mode but NAV will be disabled during VP operation.</p>
<p>GND MAP Button (RDS 81) or MAP Button (RDS 82/82VP)</p>	<p>When pressed places indicator in ground-mapping mode. Selecting ground-mapping (GND MAP) will disable the weather-alert feature and will activate the gain control. The magenta color is not activated while in the ground-mapping (GND MAP) mode.</p>
<p>NAV Button (RDS 82/82VP)</p>	<p>When pressed, places indicator in navigation mode so that preprogrammed waypoints may be displayed. If other modes are also selected, the NAV display will be superimposed on them. This button is effective only if an optional radar graphics unit and flight management system is installed. If actuated without these units, NO NAV will appear at lower left screen. The radar is still capable of displaying weather.</p>

Operation and Controls (cont.)

CONTROL/ DISPLAY	FUNCTION
GAIN Control Knob	Manual gain control becomes active <i>only</i> when ground-mapping (GND MAP) is selected. Gain is internally set in <i>all other</i> modes.
Radar Function Selector Switch (RDS 81/82/82VP)	<ol style="list-style-type: none"><li data-bbox="520 472 1006 591">1. OFF position removes primary power from the radar indicator and the sensor. The antenna is parked in the down position.<li data-bbox="520 613 1006 862">2. SBY position places system in the standby condition during warm-up and when the system is not in use. After 30 seconds in this mode during warm-up, the system is in a state of readiness. No radar transmissions occurs; the antenna is parked in the down position. STBY is displayed in the lower left of the display.<li data-bbox="520 885 1006 1003">3. TST position will display the test pattern on the indicator (see Figure 7-3); no transmission occurs. The antenna will scan while in the test (TST) mode.<li data-bbox="520 1026 1006 1182">4. ON position selects the condition of normal operation, allowing for weather detection or other modes of operation. Radar transmission exists in the ON position.
(RDS 82 Only - Used only when Bendix/King IU 2023 series radar graphics unit along with compatible long range navigation system is installed)	<ol style="list-style-type: none"><li data-bbox="520 1206 1006 1422">5. LOG position displays a listing of the latitudes and longitudes of selected waypoints. Also, if a compatible RNAV is installed, selected VOR frequencies, along with bearings and distances to waypoints, will be presented. No radar transmission occurs in this mode.

Operation and Controls (cont.)

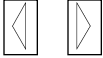
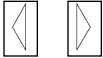
CONTROL/ DISPLAY	FUNCTION
<p>RNG Selector Buttons</p> 	<p>When pressed clears the display and increases or decreases the indicator to the next higher or lower range. Selected range is displayed in upper right corner of the last range mark (Figure 7-1) and distance to other range rings is displayed along the right edge.</p>
<p>STAB (Stabilization) Selector Button (RDS 81 Only)</p>	<p>When pressed selects STAB ON or STAB OFF operation. STAB OFF will be displayed in the upper left corner when STAB OFF is selected.</p>
<p>TRK Selector Buttons (RDS 82 Operations)</p> 	<p>When pressed provides a yellow azimuth line and a digital display of the azimuth line displacement left or right from the nose of the aircraft. The trackline is displayed for approximately 15 seconds and then removed.</p>
<p>TRK Selector Buttons (RDS 82VP Operations)</p> 	<p>When pressed provides a yellow azimuth line and a digital display of the azimuth line displacement left or right from the nose of the aircraft.</p> <p>For VP operations, the TRK button performs two functions.</p> <p>(Continued on next page)</p>

Operation and Controls (cont.)

CONTROL/ DISPLAY	FUNCTION
<p>TRK Selector Buttons(cont) (RDS 82VP Operations)</p>	<p>1. Prior to engaging VP, the appropriate button (left or right) is used to place the track line at the desired azimuth angle to be vertically scanned (sliced).</p> <p>When VP is engaged, the slice will be taken at the last position of the track line, whether it is visible or not.</p> <p>If the track line has not been selected after power has been applied to system and VP is engaged, the slice will be taken at 0 degrees (directly in front of the aircraft).</p> <hr/> <p>2. Continuously holding the TRK button will result in the system "slicing" in two-degree increments.</p>
<p>Antenna TILT Adjustment Knob</p>	<p>Permits manual adjustment of antenna tilt to a maximum of 15° up or down in order to obtain the best indicator presentation. The tilt angle is displayed in the upper right corner of the display. Depending upon the MOD status of the indicator, tilt read out may display in tenth degree.</p> <p>For 82/82VP operations, pull the Tilt selector knob out for "STAB OFF" operations. "STAB OFF" will appear in the upper left corner of the display.</p> <p>Tilt functions are disabled in VP mode.</p>

**TABLE OF CONTENTS
SECTION 10
OPERATING TIPS**

Paragraph No.		Page No.
10.1	General	10-1
10.3	Operating Tips	10-1

**FOR REFERENCE ONLY
NOT FOR FLIGHT**

**SECTION 10
OPERATING TIPS**

10.1 GENERAL

This section provides operating tips of particular value in the operation of the Malibu.

10.3 OPERATING TIPS

- (a) Learn to trim for takeoff so that only a very light back pressure on the control wheel is required to lift the airplane off the ground.
- (b) The best speed for takeoff is 75 to 85 KIAS under normal conditions. Trying to pull the airplane off the ground at too low an airspeed decreases the controllability of the airplane in the event of engine failure.
- (c) 10° of flaps may be lowered at airspeeds up to 170 KIAS and full flaps up to 120 KIAS, but to reduce flap operating loads, it is desirable to have the airplane at a slower speed before extending the flaps.
- (d) Before attempting to reset any circuit breaker, allow a two to five minute cooling off period.
- (e) Before starting the engine, check that all radio switches, light switches and the pitot heat switch are in the off position so as not to create an overloaded condition when the starter is engaged.
- (f) Anti-collision lights should not be operating when flying through cloud, fog or haze, since reflected light can produce spatial disorientation. Strobe lights should not be used in close proximity to the ground, such as during taxiing, takeoff or landing.

- (g) In an effort to avoid accidents, pilots should obtain and study the safety related information made available in FAA publications, such as regulations, advisory circulars, Aviation News, AIM and safety aids.
- (h) Prolonged slips or skids which result in excess of 2000 feet of altitude loss or other radical or extreme maneuvers which could cause uncovering of the fuel outlet must be avoided as fuel flow interruption may occur when the tank being used is not full.
- (i) Pilots who fly above 10,000 feet should be aware of the need for special physiological training. Appropriate training is available for a small fee at approximately twenty-three Air Force Bases throughout the United States. The training is free at the NASA Center in Houston and at the FAA Aeronautical Center in Oklahoma.

Forms to be completed (Physiological Training Application and Agreement) for application for the training course may be obtained by writing to the following address:

Chief of Physiological Training, AAC-143
FAA Aeronautical Center
P.O. Box 25082
Oklahoma City, Oklahoma 73125

It is recommended that all pilots who plan to fly above 10,000 feet take this training before flying this high and then take refresher training every two or three years.