



Vincent Accardi
Community Portfolio Manager
FirstService Residential
February 26, 2021

Dear Owner:

Attached please find a copy of the Census Form, Parking Sticker Application, and Pet Registration. If you haven't already sent in proof of your homeowners insurance this is also due annually. In order to do this, you should contact your insurance agent or company and request that a declaration (or certificate) of proof of insurance be sent to: Tuckerton Meadows Townhouse Association c/o FirstService Residential 125 6th Ave, Suite 201 Mt. Laurel, NJ 08054.

Please take a moment to review these documents. If you have any questions, please feel free to contact me by email Vincent.accardi@fsresidential.com. If any of these documents are not applicable to your situation please disregard them. Please return your proof of insurance and all other applicable documents and payments, included in this mailing to the above mentioned address by March 31, 2021 to avoid any fines.

Reminder notices will be sent on an annual basis but the deadline for this submission is March 31, 2021 and moving forward will return to January 30th of each year.

Sincerely,

Vince Accardi

FSRConnect™ Census Form

Section A - Association Information:

Today's Date:

Community Name:

Community Address
(Street, City, State, Zip):

Section B - Resident Information:

Owner Name: **E-mail:**

Unit Address
(Unit, Street, City, State, Zip):

Billing Address (Unit, Street, City, State, Zip):
(Fill in only if it is different from community address)

Home Phone #: **Work Phone #:** **Cell Phone #:**

Section C - Occupant Information (List all occupants and indicate if child):

<u>Name</u>	<u>Home Phone #</u>	<u>Work Phone #</u>	<u>Cell Phone #</u>	<u>E-mail:</u>

Section D - Vehicle Information (if you do not own a car, please indicate "no car"):

<u>Make & Model</u>	<u>Color</u>	<u>License #</u>	<u>State</u>	<u>Parking Spot</u> (If applicable)

Section E - Tenant Information (if applicable):

Lease Begin Date: <input style="width: 95%;" type="text"/>	Lease End Date: <input style="width: 95%;" type="text"/>			
<u>Tenant Name</u>	<u>Tenant Home #</u>	<u>Tenant Work #</u>	<u>Tenant Cell #</u>	<u>Tenant E-mail:</u>

Section F - Emergency Contact Information:

Name: <input style="width: 95%;" type="text"/>	Relationship: <input style="width: 95%;" type="text"/>	
Address <small>(Street, City, State, Zip):</small> <input style="width: 95%;" type="text"/>		
Home Phone #: <input style="width: 60%;" type="text"/>	Work Phone #: <input style="width: 60%;" type="text"/>	Cell Phone #: <input style="width: 60%;" type="text"/>
E-mail: <input style="width: 95%;" type="text"/>		

Section G - Signature:

Submitted By: <input style="width: 95%;" type="text"/>	Date: <input style="width: 95%;" type="text"/>
---------------------------------------------------------------	-------------------------------------------------------

**TUCKERTON MEADOWS HOMEOWNERS ASSOCIATION
PARKING STICKER APPLICATION AGREEMENT**



PLEASE PRINT

Name of Unit Owner: _____

Address of Unit: _____

Email Address: _____

Owner Phone Nos.: Home _____ Work _____

Name of Tenants: _____ (if applicable)

Tenant's Phone Nos.: Home _____ Work _____ (if applicable)

Vehicle Information, 1 sticker per vehicle

Vehicle License Plate Make/Model Year Color

1. _____

2. _____

3. _____

Please complete the above fields; application must include a copy of current vehicle registration for each vehicle. Parking stickers will be mailed to the above address. Parking stickers are \$5.00 each and will be billed to your HOA account. Accounts more than 2 months delinquent are subject to towing as per **Policy Resolution No.2016P Relating to Parking and Towing.** Parking resolution is available at www.tuckertonmeadows.com

By signing below, I/we agree to abide by all rules and regulations regarding the use of parking spaces and the vehicle rules.

Unit Owner Signature

Date

Applications can be mailed or emailed to:

VINCENT ACCARDI, Community Association Manager
Avenue, Suite 201 | Mt. Laurel, NJ 08054
609.546.7004 | Toll Free 800.870.0010

Email Vincent at vincent.accardi@fsresidential.com

www.fsresidential.com



Important Parking Sticker Information

Parking Stickers are required on all vehicles parked in the development.

Parking Pass applications can be downloaded at www.tuckertonmeadows.com

There is also other helpful information on the site. Applications require a copy of the vehicle registration for parking sticker to be issued.

Parking sticker placement is very important. Please use the below pictures for placement of sticker.

Accounts more than 2 months delinquent are subject to towing as per the parking resolution. Parking resolution is also available at www.tuckertonmeadows.com

Parking stickers are \$5.00 and will be billed to your account.

Thank You for your help.

Parking Sticker Placement

Sticker placement for vehicles, **outside of the vehicle**,

red **X** indicates placement for sticker so it can be easily see.

Driver Side Rear of the vehicle.

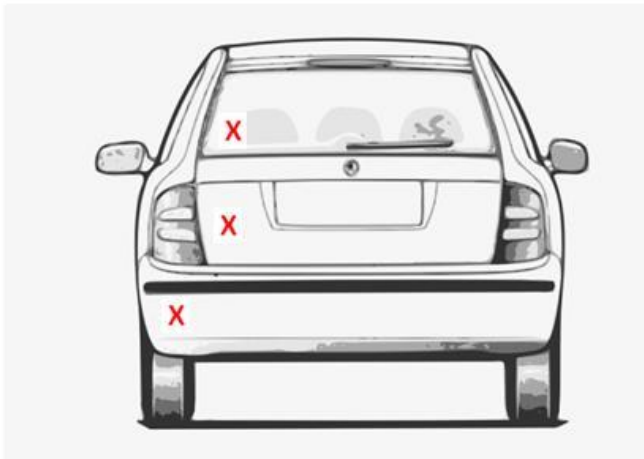

Sticker Placement for Pick-up Trucks, outside of the truck.

Driver Side Rear of the vehicle.

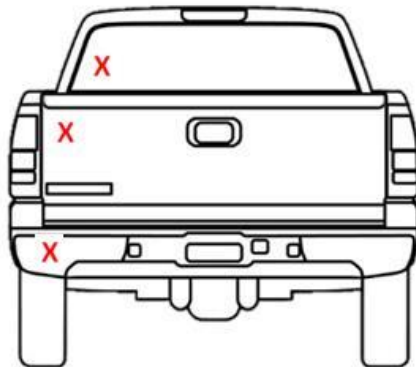

This is the New Parking Sticker



TUCKERTON MEADOWS ASSOCIATION

PET REGISTRATION FORM

Tuckerton Meadows Association By-Laws require registration with the Association of all pets.

Please sign and complete this entire form. **Attach a recent photo of pets and copy of pet license.**

Type of Pet _____

Pet Name _____

Color _____

Weight _____

Breed _____

Distinctive Markings _____

OR

_____ **There are no pets residing at my unit.**

Please be aware that all dogs over 4 months old are required by law to be licensed and vaccinated for rabies. Please return a copy of the license with this form.

Is your pet licensed? Yes _____ No _____

Is your pet vaccinated for rabies? Yes _____ No _____

I have read and agree to keep my pet in full compliance with the Association By-Laws. I understand that, for sanitary reasons, I am responsible for the IMMEDIATE collection and proper disposal of all fecal matter deposited by my pet any place in the Common Areas. The Association will assess a fine if fecal matter is not properly cleaned up. I understand it is my responsibility to notify the Association of any change in this registration.

Owners Name: _____

Address _____

Phone Number _____

Signature _____ Date _____

N.J. DOG LICENSE APPLICATION

BOROUGH OF TUCKERTON, 140 EAST MAIN STREET, TUCKERTON., NJ

08087

This license to own, keep or harbor the dog described below is issued to:

Name _____ Date _____

Address _____ Telephone _____

Dog Sex: _____ Age: _____ Breed: _____ Hair Length S M L

(Circle One)

Color & Markings: _____ Name: _____

Spayed/Neutered – Yes No Date _____ By _____

Spayed Non-spade

Neutered Non-Neutered Rabies Vaccination Compulsory

License Fee 4.80 4.80 Vaccination Expires _____

N.J. Registration Fee 1.00 1.00

N.J. Pilot Clinic Fund .20 .20

N.J. Pet Population Control --- 3.00

TOTAL \$6.00 \$9.00 Licensing Official

Late Fee From 1/31 – 5/31 \$5.00 \$5.00

Late Fee After 5/31 \$10.00 \$10.00