

4 X 6 X 10 FOOT UNIVERSAL TOWER ASSEMBLY

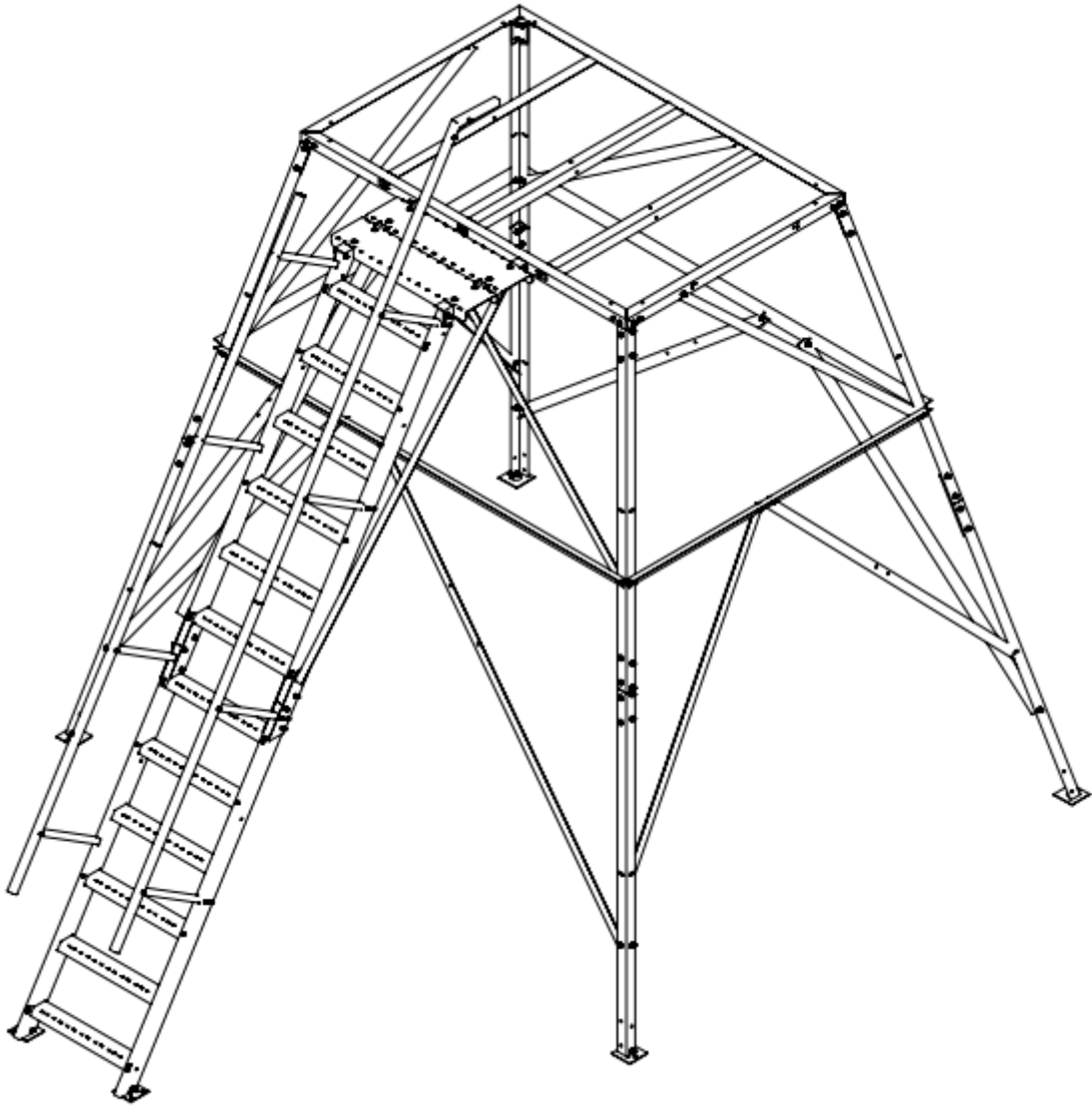

1. Lift the base to 5 feet high.
2. Attach 4 legs to the leg anchors on the base with 4 - 3/8 x 1" bolts & 4 - 3/8" nylon lock nuts for each leg. Do not tighten these at this time. (Fig 1)
3. Attach 71" brace to the base on the long side using 1 - 3/8" x 1" bolt & 1 - 3/8" nylon lock nut. Repeat on the opposite side of base. Do not tighten these at this time. (Fig 2)
4. Attach 89 3/8" brace and the free end of 71" brace from step 3 to the leg. Repeat on the opposite side of base. Do not tighten these at this time. (Fig 3)
5. Attach the free end of 89 3/8" horizontal brace from step 4 to the opposite leg. Repeat on the opposite side of base. Do not tighten these at this time. (Fig 4)
6. Attach 62" brace to the base on the narrow side using 1 - 3/8" x 1" bolt & 1 - 3/8" nylon lock nut using the same sequence as step 3. Repeat on the opposite side of base. Do not tighten these at this time. (Fig 5)
7. Attach 65 3/4" brace and the free end of 62" brace from step 6 to the leg using the same sequence as step 4. Repeat on the opposite side of base. Do not tighten these at this time. (Fig 5)
8. Attach the free end of 65 3/4" horizontal brace from step 7 to the opposite leg. (Fig 5)
9. Set the tower down, adjust legs so that they all contact the ground, & tighten all the fasteners.
10. Place left and right infinity platform anchors on the rail of the base centered on the approximate door location of the blind. (Fig 6)
11. If installing a blind it can be lifted onto the tower and secured to the base now.

UNIVERSAL TOWER PLATFORM ATTACHMENT

12. Attach the platform over the anchors in step 10 and secure with 2 - 3/8" x 1" bolt, 2 - 3/8" flat washer, & 2 - 3/8" nylon lock nuts. (Fig 7)

UNIVERSAL TOWER BOTTOM SECTION ASSEMBLY

13. Attach tower feet to remaining tower legs with 3/8 x 1" bolts & 3/8" nylon lock nuts. Do not tighten these at this time. (Fig 8)
14. Raise the 5 foot tower assembly 5 feet.
15. Install a tower leg splice and bottom legs to the bottom of each leg on the 5 foot tower assembly using 8 - 3/8" x 1" bolts & 8 - 3/8" nylon lock nuts on each. Do not tighten these at this time. (Fig 9)
16. Attach the 89 3/8 brace to the horizontal cross bar and the lower leg on the long side using 2 - 3/8" x 1" bolts & 2 - 3/8" nylon lock nuts. Repeat on the opposite side. Do not tighten these at this time. (Fig 10)
17. Attach the 71" brace to the horizontal cross bar and the lower leg on the long side using 2 - 3/8" x 1" bolts & 2 - 3/8" nylon lock nuts. Repeat on the opposite side. Do not tighten these at this time. (Fig 11)
18. Attach the 65 3/4" brace to the horizontal cross bar and the lower leg on the narrow side using 2 - 3/8" x 1" bolts & 2 - 3/8" nylon lock nuts. Repeat on the opposite side. Do not tighten these at this time. (Fig 12)
19. Attach the 62" brace to the horizontal cross bar and the lower leg on the narrow side using 2 - 3/8" x 1" bolts & 2 - 3/8" nylon lock nuts. Repeat on the opposite side. (Fig 13)
20. Set the tower down, adjust legs so that they all contact the ground & tighten all the fasteners in steps #15-20-

UNIVERSAL TOWER LADDER ASSEMBLY

21. Attach ladder feet to the bottom of one of the ladder sections by inserting 2 1/2" carriage bolts through the ladder bottom hole and the hole on the foot tab. Put 3/8" nylon lock nuts on bolts.
22. Install ladder splice plates to lower section of ladder with 4 - 3/8 x 2 1/2" carriage bolts and 4 nylon locking nuts. Do not tighten these at this time. (Fig 14)

23. Assemble top and bottom ladder sections with 2 - 3/8 x 2 3/4" carriage bolts in the top holes on the splice plates and 2 - 3/8 x 2 1/2" carriage bolts in the remaining holes on the splice plate. Secure the 2 3/4" bolts with non-locking nuts and the other 2 carriage bolts with 3/8" nylon lock nuts. All of these nuts can be tightened now. (Fig 15)

UNIVERSAL TOWER LADDER INSTALLATION

24. Place ladder between angle iron protruding from the platform making sure to get the ladder tube end over the screws in the platform. Insert 2 - 3/8 x 2 1/2" carriage bolt through the ladder and the slotted hole on the platform. Put 3/8" nylon lock nuts on the bolts. Do not tighten these at this time.
25. Attach the 71" ladder braces to the holes in the bottom of the platform with 3/8" x 1" bolts & 3/8" nylon lock nuts. Do not tighten these at this time.
26. Attach the opposite end of 71" brace to the ladder by putting slot over the 2 3/4" bolt on the ladder splice plate. Do not tighten these at this time.
27. Level the platform by placing the ladder at the proper angle. Tighten all fasteners in steps 24-26 while holding the platform level.

UNIVERSAL TOWER LADDER RAILING INSTALLATION

28. Install the two bottom straight railings into the square holes in the lower ladder section with the longer part of the railing at the top. Secure these railings by installing 8 self-drilling screws through the holes in the side of the ladder into the pilot holes in the railing balusters. Tighten these fasteners now. Repeat this process for the top railings putting the straight rail on the left with the longer part of the rail at the bottom and the bend rail on the right.
29. Once platform position is confirmed the infinity platform anchors can be locked in place with the #12 x 1" TEK screw.

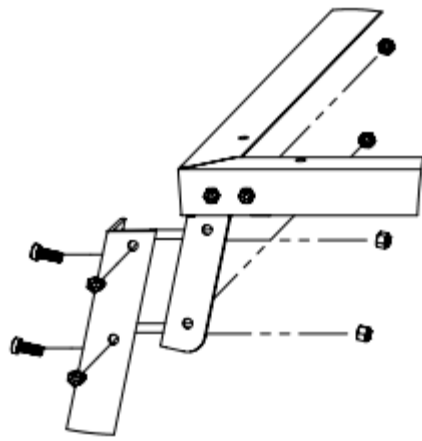
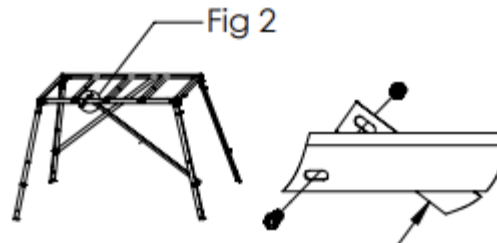
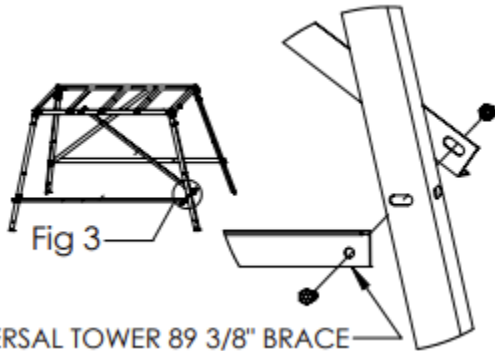

Fig 1



UNIVERSAL TOWER 71" BRACE



UNIVERSAL TOWER 89 3/8" BRACE

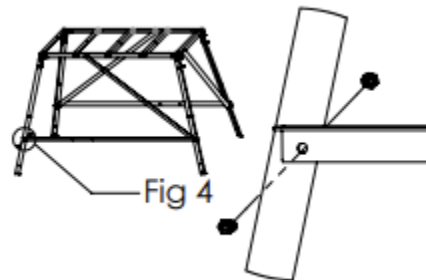

UNIVERSAL TOWER 62" BRACE
UNIVERSAL TOWER 65 3/4" BRACE

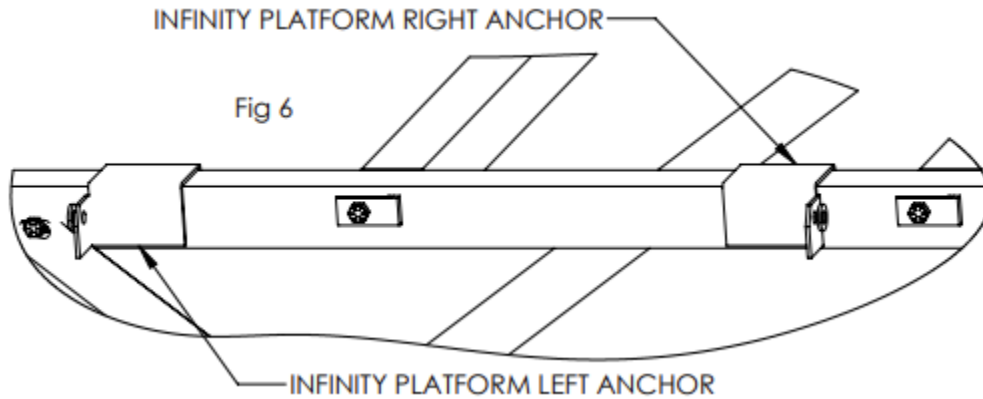

INFINITY PLATFORM RIGHT ANCHOR

Fig 6

INFINITY PLATFORM LEFT ANCHOR

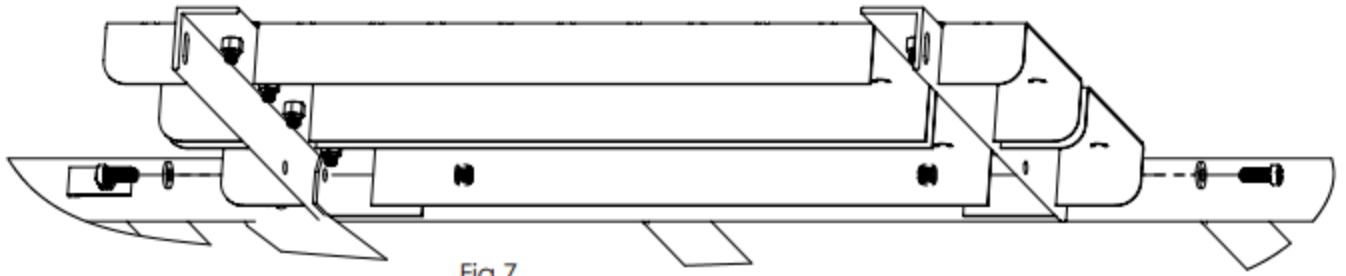

Fig 7

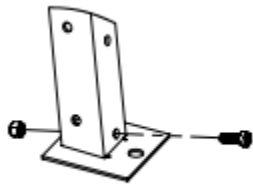

Fig 8

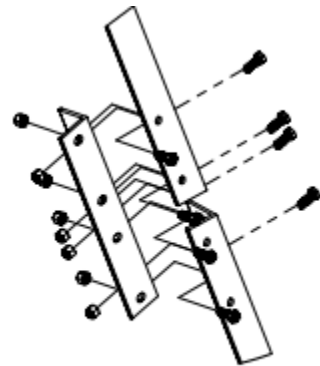

Fig 9

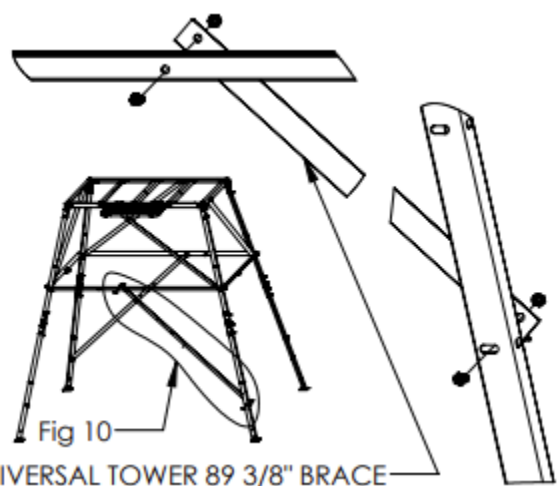

Fig 10

UNIVERSAL TOWER 89 3/8" BRACE

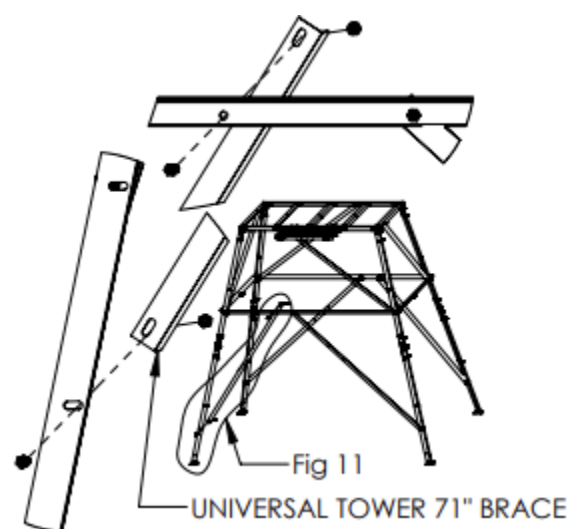

Fig 11

UNIVERSAL TOWER 71" BRACE

UNIVERSAL TOWER 65 3/4" BRACE

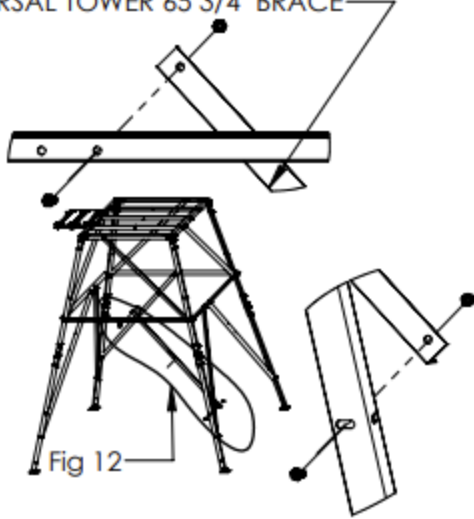

Fig 12

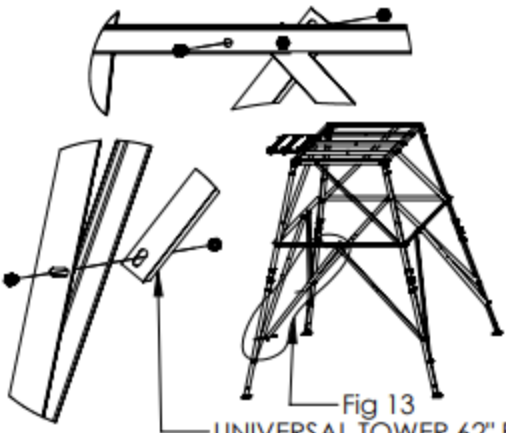

Fig 13

UNIVERSAL TOWER 62" BRACE

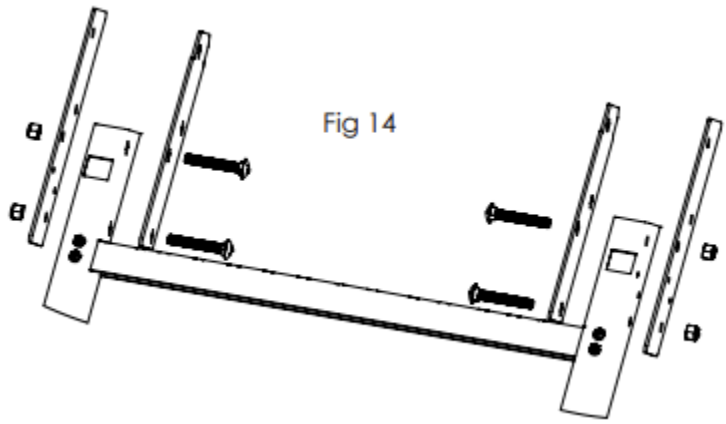

Fig 14

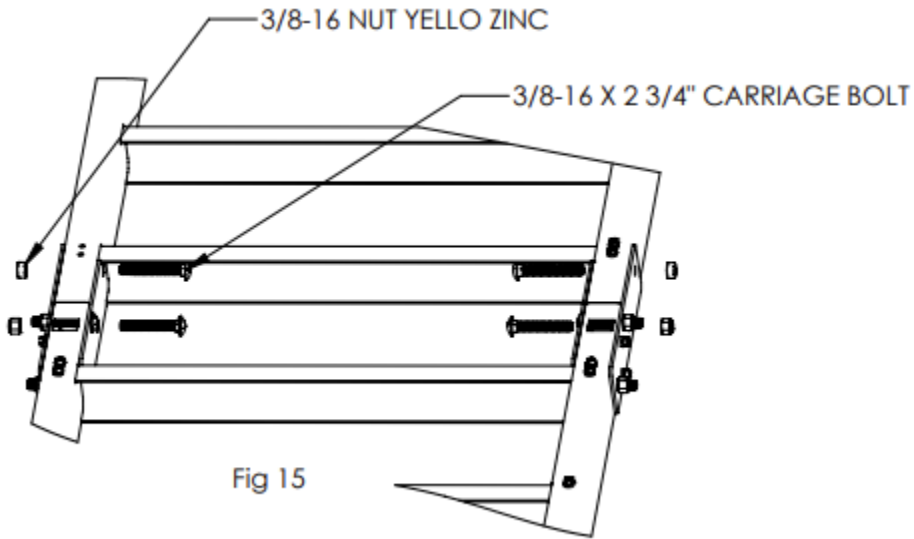

Fig 15