

# ROYAL ENFIELD OWNER'S MANUAL

---

---

USA/CALIFORNIA - CLASSIC 350/SIGNALS 350



**ABS**  
DUAL CHANNEL



---

---

## **FOREWORD**

Congratulations!

Welcome to the Royal Enfield family. And to a world of motorcycling that has an enviable heritage, including being the world's oldest motorcycle marque in continuous production.

Since its introduction in 2008, the Classic 350 has captured the imagination of motorcycling enthusiasts across the world with its vintage inspired build, authentic styling and timeless appeal. Taking riders on journeys of exploration and discovery beyond the known.

In your All new Classic/Signals 350, old-school dependability meets modern technology with an all-new 349 cc air-oil-cooled engine and a new frame, for unmatched rideability and a refined experience no matter where your journey takes you.

This manual will guide you and help you to operate and maintain your All new Classic/Signals 350 motorcycle the right way. Please do avail all the services at your nearest Royal Enfield Authorised Service Centre, ensuring your ride gets the best care always.

Do read through the terms and conditions of warranty and other useful information given in this manual before you ride.

Let the rides begin!

---

---

---

## **NOTICE**

---

All information in this manual is based on the latest product information available at the time of publication. Due to continuous improvements, there may be differences between the information provided in this manual and information related to your motorcycle.

Always consult an authorized Royal Enfield dealer for the latest specifications, features etc. Royal Enfield reserves the right to make production changes at any time without prior notice and without incurring any obligation to make the same or similar changes to a motorcycle previously built or sold.

All images shown are for reference to explain and need not to be exactly the same on the model you own. Accessories and features may not be part of standard equipment. Technical specifications are subject to change without prior notice at the sole discretion of Royal Enfield.

“© Copyright 2021 Royal Enfield (A unit of Eicher Motors Ltd.). All Rights Reserved. No part of this manual shall be copied, distributed or otherwise dealt without the express permission in writing from Royal Enfield”.

Avail further details on the products Repair and Maintenance Instructions at <https://serviceinfo.royalenfield.com> through a paid subscription.

### **DISCLAIMER**

Following precautions are to be taken, to ensure longer paint life of your motorcycle.

- Do not polish your motorcycle as it decreases gloss.
- Wash only with plain water.
- Scratches or marks cannot be removed or touched up.

Toll Free No : 1-866-600-1122

Email ID : [U.Scustomerservice@royalenfield.com](mailto:U.Scustomerservice@royalenfield.com)

Part No. RAM00359/A / Qty / December 2021



---

## **IMPORTANT**

---

United States Environment Protection laws, Federal Motor Vehicle Safety Standards and California Air Resources Board (Applicable only for motorcycles sold within the state of California.) strictly prohibits tampering with the Exhaust Emission Control, Noise Control and Evaporative Emission Control systems:

We would like to emphasize that any repairs to the induction, emission, exhaust and evaporative systems must be performed only by a Royal Enfield Authorized Dealer so that the motorcycle conforms to the United States Environment Protection laws, Federal Motor Vehicle Safety Standards and California Air Resources Board regulation (Applicable only for motorcycles sold within the state of California.)

It is the responsibility of the Owner/User of the motorcycle to read this manual carefully and to comply with the safety guidelines, operating instructions and periodical maintenance instructions given here. Keep this manual in a convenient place for easy reference. Do not use the motorcycle until you have become familiar with this motorcycle and after reading and understanding this manual completely. In case you need any further clarifications, please contact a Royal Enfield Authorized Dealer, nearest to you, for assistance.

If your motorcycle is being used by a friend, relative, or any other person, it is your responsibility to make certain that they have completely understood the operating procedures of the motorcycle and the contents in this manual with particular reference to the safety aspects, before riding your motorcycle.

This motorcycle is designed for normal on road use only. Operation in off-road usage in some areas may be illegal and could be dangerous. Please obey local laws and regulations.

In the event of your motorcycle being sold to another person, it is your responsibility to hand over this manual along with the motorcycle to the new owner.

---

## **REPORTING SAFETY DEFECTS**

---

If you believe your motorcycle has a defect which could cause a crash and result in serious injury or loss of life, you should immediately contact the National Highway Traffic Safety Administration (NHTSA) in addition to notifying Royal Enfield North America Limited, 226 N Water St., Milwaukee WI 53202 US.

If NHTSA receives similar complaints, it may open an investigation and if it finds that a safety defect exists in a group of vehicles, it may order a recall and remedy campaign. However, NHTSA cannot become involved in any individual problems between you, and your dealer or Royal Enfield North America Limited.

To contact NHTSA you may call the Auto Safety Hotline toll-free within the United States on 1-800-424-9393 or write to: NHTSA, 400 Seventh Street SW, Washington, DC 20590. You can also obtain other information about motor vehicle safety from the hotline.

---

## CONTENTS

---

Important .....	3	Parking .....	66
Safety Definitions .....	6	Tools Kit .....	67
Personal and Motorcycle Information .....	7	Minor Maintenance Tips .....	68
Safe Riding Tips/ Guidelines .....	8	Rear Suspension Setting .....	80
Rules of the Road .....	13	Long Trip Precautions .....	82
Accessories and Luggage .....	16	Washing Procedure .....	83
Technical Specifications .....	19	Storage Precautions .....	86
Recommended Lubricants .....	25	Environment Care .....	87
Motorcycle Identification Numbers .....	26	Periodical Maintenance Chart .....	89
Engine Number Details .....	29	Warranty Terms and Conditions .....	95
Location of Key Parts .....	31	Emission Warranty .....	99
Operation of Controls .....	34	Noise Control System Warranty .....	108
Warning Indications and Safety Systems .....	50	EVAP.....	109
Pre-Operational Checks .....	55	Wiring Diagram .....	110
Running in Period .....	56	Radio Type Approval .....	111
Starting .....	57	Service/Maintenance Record .....	112
Gear Shifting, Riding and Stopping .....	62	Notes .....	113

---

## **SAFETY DEFINITIONS**

---

The information given under the titles : Warning, caution and note are for your safety and for the care and safety to your motorcycle and others. Please read these carefully and if disregarded may result in injury to yourself or others and damages to the motorcycle.



---

### **WARNING**

---

Indicates a potentially hazardous situation. Disregarding this message may result in injury to rider or other persons.

---

### **CAUTION**

---

This message, if disregarded, may result in damage to the motorcycle.

---

### **NOTE**

---

Indicates important and useful messages for better understanding.

## PERSONAL AND MOTORCYCLE INFORMATION

Name																						
Door No./ Street																						
Locality/ Town																						
City											Country											
Contact	Res :											Off :										
	Mobile :											Email :										
Licence No.											Valid till :											
Model											Color :											
Engine No.																						
VIN. No.																						
Tyre make	Front :										Rear :											
Tyre Nos.	Front :										Rear :											
Battery make											Battery No.											
Sold by																						
Date of Sale																						

---

## SAFE RIDING TIPS/GUIDELINES

---

- Before operating your new motorcycle, we request you to carefully read and follow the operating and maintenance instructions detailed in this manual for the safety of your own, your motorcycle and also that of others.

- Know and adhere to the rules of the road with respect to your driving country.

Before starting the motorcycle, check for proper operation of brakes, clutch, gear shifter, handle bar controls, tyre pressures, fuel and oil levels, etc.

Use only genuine Royal Enfield spare parts and approved accessories. Use of other manufacturer's parts may affect the performance of your motorcycle and render the motorcycle void of warranty.

Visit your Royal Enfield Authorised Service Centre for details.

- Whenever refueling your motorcycle, please exercise utmost caution and carefully observe the following guidelines.

- ★ Refuel in a well ventilated area with the engine turned off condition.
- ★ Open the fuel tank cap slowly.
- ★ Switch "OFF" mobile phones and other hand held electronic devices.
- ★ Do not smoke and please ensure that there are no open flames or sparks near the motorcycle, when refueling or servicing the fuel system.

---

## SAFE RIDING TIPS/GUIDELINES

---

- ★ Do not fill the fuel in tank to its brim. Please fill fuel till the bottom of anti splash plate, so as to leave sufficient air space in the fuel tank to allow for fuel expansion.



---

### WARNING

---

Royal Enfield cautions you against the use of certain nonstandard parts such as aftermarket and custom made extended front forks or suspensions, which may adversely affect performance and handling. Removing or altering original parts may adversely affect performance and could result in accident.

- A new motorcycle must be operated according to the special running-in-procedure. See running-in procedure mentioned in respective section.
- Operate motorcycle only at moderate speeds and out of traffic until you have become thoroughly familiar with its operation and handling characteristics under all conditions.
- Do not exceed the legal speed limit or ride too fast for existing conditions. Always reduce speed when poor riding conditions exist. High speed increases the influence of any other condition affecting stability and increases the possibility of loss of control.

---

## SAFE RIDING TIPS/GUIDELINES

---

### NOTE

---

If you are an inexperienced rider we recommend that you obtain formal training on correct motorcycle riding techniques and become thoroughly familiar with the operation of your motorcycle. New riders should again experience under various conditions while driving moderate speeds.

Pay strict attention to road surfaces and wind conditions. Any motorcycle may be subject to the following up-setting forces :

- ★ Wind blasts from passing vehicles.
- ★ Rough or uneven road surfaces.
- ★ Slippery road surfaces.

These forces may affect the handling characteristics of your motorcycle. If this happens, reduce speed of the motorcycle to a controlled condition. Do not apply brake abruptly.

- Operate your motorcycle defensively. Remember that a motorcycle does not afford the same protection as an automobile in an accident. One of the most common accident situations occurs when the rider/driver of the other motorcycle/vehicle fails to see or recognise a motorcycle and turns into the oncoming motorcyclist.
- Wear an approved helmet, clothing and footwear suited for riding a motorcycle. Bright/light colours are best for greater visibility in traffic, especially at night. Avoid loose, flowing garments and scarves.



---

## SAFE RIDING TIPS/GUIDELINES

---

- When carrying a pillion rider, it is your responsibility to instruct them on proper riding procedures.
  - Do not allow other individuals, under any circumstances, to operate your motorcycle unless you know they are experienced, licensed riders and are thoroughly familiar with the operating conditions of your motorcycle.
-  **WARNING**
- 
- Regularly inspect shock absorbers and front forks and look for leaks. Replace worn out parts. Worn out parts can adversely affect stability and handling.
  - For your personal welfare, all the listed service and maintenance recommendations should be performed. Lack of regular maintenance at the suggested intervals may affect the safe/durability/longevity operation of your motorcycle.
  - Avoid any contact with the exhaust system when hot. Wear clothing that will completely cover the legs while riding. The exhaust system gets very hot when the engine is running and remains too hot to touch, even after the engine is turned off. Failure to wear proper or protective clothing could result in serious injury.
  - Exhaust gas contains poisonous carbon monoxide and chemicals, known to cause cancer, birth defects or other reproductive defects.

---

## SAFE RIDING TIPS/GUIDELINES

---



### WARNING

---

- Motorcycle batteries contain lead, acids and chemicals known to cause cancer, birth defects or other reproductive harm. Exercise extreme caution while handling a battery, wash hands thoroughly whenever a battery is handled.
- Consult your Royal Enfield Authorised Service Centre regarding any questions or problems that occur in the operation of your motorcycle. Failure to do so may aggravate an initial problem, cause costly repairs and jeopardize your personal safety.
- Do not tow a motorcycle. The steering and handling of the towed motorcycle will be impaired due to the force of the towline. If a motorcycle must be transported, use a truck or a trailer.
- Do not pull a trailer behind a motorcycle. Towing a trailer may cause reduced braking efficiency, tyre overloading and unstable handling, as it may cause loss of control of the motorcycle in the front, leading to an accident.

---

## **RULES OF THE ROAD**

---

- Be sure your number plate is installed in the position specified by law and it is clearly visible at all times.
- Ride at a safe speed that is consistent with the type of road surface you are on. Pay strict attention while riding on the following surfaces:
  - ★ Dusty
  - ★ Oily
  - ★ Icy
  - ★ Wet
  - ★ Sand
- Watch for loose debris, such as leaves, slippery, substances or gravel that can hamper the stability of your motorcycle.
- Keep to the correct side of the road center line, when meeting oncoming vehicles.
- Actuate your turn signals and exercise caution when passing other vehicles going in the same direction. Never try to pass another vehicle going in the same direction at street intersections, on curves, or when going up/or down a hill.
- At street intersection give the right-of-way to the motorcycle on your left or right. Do not presume you have the right-of-way.
- Adhere to the rules of the road with respect to your country when preparing to stop, turn or pass. While turning either right or left, watch for pedestrians, animals, as well as other vehicles.

---

## RULES OF THE ROAD

---

- All traffic signs, including manual controls at intersections, should be obeyed promptly. Slow Down at traffic signs near schools and caution signs at rail road crossings.
- When intending to turn, signal at least 30.5 m before reaching the turning. Be close to the center line (unless local rules require otherwise), slow down and then turn carefully.
- Never jump a traffic light. When a change is imminent from Go to Stop (or vice versa) at intersections, slow down and wait

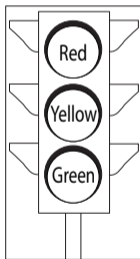

for the light to change to green, Near run through a yellow or red traffic light.

- Do not leave the curb or parking area without signaling. Be sure your way is clear to enter moving traffic. A moving line of traffic always has the right-of-way.
- When parking the motorcycle, park on a firm and flat surface to prevent it from falling over.
- Protect your motorcycle against theft. After parking your motorcycle, ensure that the steering head is locked and then remove the ignition key.

---

# RULES OF THE ROAD

---

## SIDE VIEW MIRRORS

---

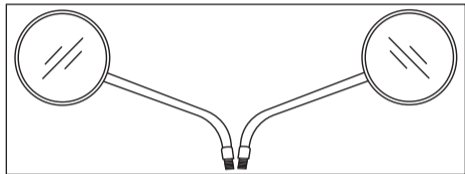

Your motorcycle is equipped with convex mirrors and have a curved surface. This type of mirror is designed to give a much wider view of the rear than a normal flat mirror. However, vehicles and other objects seen in this type of mirror will look smaller and farther away than when seen in a flat mirror.

Use care when judging the size or distance of vehicles/objects seen in these mirrors.

## NOTE

---

To establish the relative distance of vehicles/objects behind your motorcycle through the mirrors, adjust each mirror in such a way, that a small portion of your shoulder is visible and a large portion behind your motorcycle is seen clearly with reference to your riding posture.

---

## ACCESSORIES AND LUGGAGE

---

Royal Enfield offers a range of genuine motorcycle accessories that have been fully approved and extensively tested alongside the motorcycle. We strongly recommend using them for ensuring performance. Fitment of accessories which are not tested and approved by Royal Enfield may affect the performance or life of the components for which Royal Enfield cannot be held responsible and Royal Enfield reserves the right not to accept such failures or issues under the scope of warranty.

Therefore, the rider must be responsible for safe operation of the motor cycle when installing accessories or carrying additional weight.

Please adhere to the following guidelines when carrying a pillion, luggage or when fitting any accessories.

- Do not exceed 68.3 mph when riding solo, carrying a pillion or payload on an accessory equipped motorcycle.
- Keep luggage weight concentrated close to the motorcycle and as low as possible; this minimizes sudden shift in the motorcycle's center of gravity.
- Distribute weight evenly on both sides of the motorcycle.
- Do not load bulky items behind the rider or add weight to the handlebars or front forks.
- Re-check the luggage periodically to ensure it is secured and will not shift while riding. Accessories mounted loosely may affect the riding of the motorcycle and affect the handling and stability of the motorcycle.

---

## ACCESSORIES AND LUGGAGE

---

- Large surfaces such as fairings, windshields, backrests and luggage racks can adversely affect handling of the motorcycle. Use Royal Enfield genuine motorcycle accessories which are model specific and follow installation procedure.



---

### WARNING

---

- Do not load weight or install accessories incorrectly on the motorcycle. Doing so may affect the motorcycle's stability, handling characteristics and safe operation and could result in an accident causing serious injury or loss of life.
- Royal Enfield offers a range of genuine motorcycle accessories that have been fully approved and extensively tested alongside the motorcycle.
- Royal Enfield cautions you against use of non-standard parts such as aftermarket and custom made extended front forks which may adversely affect the performance and handling of the motorcycle. Removing or altering original parts may adversely affect the performance of the motorcycle, causing an accident, which could result in serious injury or loss of life.
- Do not ignore model / design specifications. Doing so constitutes both motorcycle and accessories misuse which may adversely affect the handling and performance of the motorcycle causing an accident, which could result in serious injury or loss of life.

---

## ACCESSORIES AND LUGGAGE

---

- Total weight and axle loads influence the handling characteristic of the motorcycle.

The total weight consists of the following:

- a. Motorcycle ready for operation and with a full tank.
  - b. Rider
  - c. Passenger
  - d. Protective clothing and helmet.
  - e. Luggage/accessories.
- Do not exceed the maximum permissible overall weight or the axle loads.
  - If your motorcycle is equipped with saddlebags, a windshield or a passenger backrest, be prepared to reduce operating speed to maintain stability.



### WARNING

---

- A high payload alters the handling characteristic and increases the stopping distance of the motorcycle.
- Riding off-road, riding with more than one passenger, or carrying weight exceeding the maximum weight rating can make handling difficult, which may cause loss of control of the motorcycle which may cause injury to the rider.



---

## TECHNICAL SPECIFICATIONS

---

### ENGINE

---

Engine Type.....	4 Stroke, Air cooled engine, Spark ignition. Single cylinder
Bore.....	72 mm
Stroke.....	85.8 mm
Engine capacity (cc).....	349.34 cc
Compression ratio.....	9.5:1
Max power .....	14.87 kW @ 6100 rpm 20.21 PS @ 6100 rpm
Max torque.....	27 Nm @ 4000 rpm
Idle RPM .....	1050 ± 100 rpm

Starting.....	E-Start
Air filter element .....	Paper element
Lubrication oil .....	SAE 15W 50 API SL Grade JASO MA2 Semi Synthetic Oil
Engine oil capacity .....	2.20 l

---

### IGNITION SYSTEM

---

Ignition type .....	ECU controlled/EFI (with ECU map number)
Spark plug gap.....	0.7 to 0.8 mm
Spark plug .....	YR7MES/Bosch

---

## TECHNICAL SPECIFICATIONS

---

### TRANSMISSION

---

Clutch ..... Conventional wet clutch

Primary drive..... Gear

Primary ratio..... 2.313

Gear box ..... Constant mesh

Gear ratio

1 <sup>st</sup>	2.615
-----------------	-------

2 <sup>nd</sup>	1.706
-----------------	-------

3 <sup>rd</sup>	1.300
-----------------	-------

4 <sup>th</sup>	1.040
-----------------	-------

5 <sup>th</sup>	0.875
-----------------	-------

Final drive..... Chain

Secondary sprocket ratio .... 2.800:1

Drive chain links ..... 104 links

---

# TECHNICAL SPECIFICATIONS

---

## CHASSIS

---

Frame .....	Twin downtube Spine frame
Suspension	
Front.....	Telescopic, 41 mm forks, 190 mm travel
Rear .....	Twin tube emulsion shock absorbers with 6 step adjustable preload, 90 mm travel
Brakes	
Front disc.....	300 mm disc with twin piston floating caliper
Rear disc .....	270 mm disc, single piston floating caliper
ABS.....	Dual channel

### Tyre size

Type of Wheel	Standard Type
Front	Make : CEAT Zoom plus F TL & CEAT Zoom plus F TT Size : 100/90 - 19 M/C 57 P
Rear	Make : CEAT Zoom plus FTL & CEAT Zoom plus F TT Size : 120/80-18 M/C 62P

---

## TECHNICAL SPECIFICATIONS

---

### CHASSIS

---

Tyre pressure		Fuel type.....	Petrol, upto E10 minimum
Solo		Fuel tank capacity .....	13 ± 0.5* l
Front.....	32 psi	Minimum octane rating.....	91 RON
Rear .....	32 psi	Low fuel warning.....	4 ± 0.5 l (Including dead stock)
With pillion		Fuel dead stock .....	1.5 +/- 0.5 l
Front.....	32 psi		
Rear .....	36 psi		
Steering lock.....	Integrated with ignition lock		

\* The above values are approximate and the actual fuel filling capacity will vary from the values mentioned.

---

## TECHNICAL SPECIFICATIONS

---

### ELECTRICALS

---

Generation .....	Alternator (ACG)	Hazard warning.....	12 V - 10 W x 4 nos
Battery .....	12 V - 8 Ah VRLA (maintenance free)	Horn .....	Single tone - K95 - 2.5 A
Starter motor .....	12 V - 0.7 kW	Charger port.....	USB 2.0 Type A - 5 V 2 A Output
Head lamp .....	12 V, H 4 - 60/55 W (Halogen) with LED light guide		
Front position lamp.....	12 V, LED type- 2. 4/1.2 W		
Brake/Tail lamp.....	12 V, 21/5W Bulb		
Speedometer lamp .....	12 V - LED		
Hi-beam indicator .....	12 V - LED		
Neutral lamp tell tale .....	12 V - LED		
Turn signal tell tale .....	12 V - LED		
Turn signal .....	12 V, 10 W x 2 nos		



#### **WARNING**

Using bulbs / other electrical gadgets other than specified rating may lead to over loading / erratic behaviour / premature failure of electrical system. Modifications on the motorcycle which are not approved by Royal Enfield may not only disqualify for warranty, but also affects performance of the motorcycle.

---

## TECHNICAL SPECIFICATIONS

---

### DIMENSIONS

---

Length .....	2130 mm
Width.....	785 mm
Wheel base.....	1390 mm
Ground clearance .....	170 mm
Total height .....	1090 mm* (without windshield) *Mirrors are excluded for Height measurement.
Saddle height .....	805 mm

### WEIGHTS

---

Kerb weight (90% fuel & oil)...	191 kg
Gross vehicle weight .....	375 kg

### NOTES

---

- Values/dimensions given above are for your guidance only.
- In view of continuous improvements being done on our products, the specifications are likely to change without prior notice.
- Do not use the vehicle beyond the allowed gross weight. The suspensions and tyres are designed to perform only to the maximum gross vehicle weight.

---

## RECOMMENDED LUBRICANTS

---

Engine Oil	
Grade	SAE 15W 50 API SL Grade JASO MA2 Semi synthetic
Capacity	Refill : 1.7 l (Approx.) Dry fill : 2.2 l (Approx.)

Front Fork Oil	
Grade	Royal Enfield fork oil
Capacity	380 cc

Brake Fluid	
Grade	Dot 4
Capacity	Front : 87 ml Rear : 54 ml

\* Do not mix Dot 4 & other brake fluids together.

---

### CAUTION

---

Use of wrong grade/mixed grade oil will reduce the life of the moving parts and seriously affect performance.

---

### NOTE

---

Recommendation subject to change without notice.

# MOTORCYCLE IDENTIFICATION NUMBERS

The VIN is a 17 digit number punched on the right side steering head tube in the form of label.

## Sample VIN :

	ME3	F	A	P	20	X	X	X	3	XXXXXX
World manufacturer identification ( WMI )	ME3									
Make and Type and Line										
Model										
Engine Type										
P - (J1-349) Four Stroke										
Single cylinder Vertical,										
349.3cc engine capacity										
Net brake horse power										
of the engine in hp										
Check digit										
Model year										
Plant location										
C - Chennai, K - Kanchipuram,										
V - Vallam Vadagal										
Engine capacity										
3 - indicating 349.3cc										
Running serial number										



---

# MOTORCYCLE IDENTIFICATION NUMBERS

---

---

## VIN LABEL PUNCHING

---

The right hand side headstock gusset.

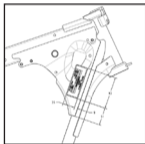

---

## CAUTION

---

It is illegal to tamper with the VIN information label as it is the only means of identifications of the motorcycle.

---

## NOISE LABEL

---

The noise label on The front side of the down tube lower end at the right-hand side of the vehicle.

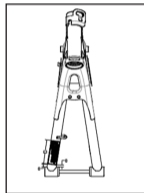
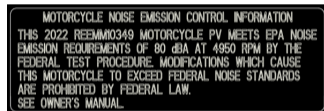

---

## CAUTION

---

It is illegal to tamper with the VIN information label as it is the only means of identifications of the motorcycle.

# MOTORCYCLE IDENTIFICATION NUMBERS

## EMISSION LABEL PART 1

The location of the emissions label part 1, on the LH side of the headstock tube.

VEHICLE EMISSION CONTROL INFORMATION - PART 1			
THIS VEHICLE CONFORMS TO US EPA AND CALIFORNIA ARB REGULATIONS APPLICABLE TO 2022 MODEL YEAR NEW MOTORCYCLES AND IS CERTIFIED TO 0.8 g/km HC + NOx AND 12 g/km CO EMISSION STANDARDS			
ENGINE FAMILY NRECO35PJ2	PERMEATION FAMILY NREEPMETALPJ	EVAP FAMILY NREEU00MPJ1	DISPLACEMENT 349cc
MANUFACTURER: ROYAL ENFIELD, A UNIT OF EICHER MOTORS LIMITED, INDIA IMPORTER: ROYAL ENFIELD NORTH AMERICA LIMITED (SUBSIDIARY OF EICHER MOTORS LIMITED, INDIA), MILWAUKEE, WI 53202			

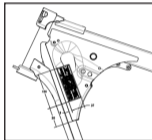

## CAUTION

It is illegal to tamper with the VIN information label as it is the only means of identifications of the motorcycle.

28 | Royal Enfield All New Classic 350/Signals 350

## EMISSION LABEL PART 2

The front side of the down tube lower end at the left hand side of the vehicle.

VEHICLE EMISSION CONTROL INFORMATION - PART 2	
<b>EXHAUST EMISSION CONTROL SYSTEM</b> <p>FUEL CAP WITH TWO WAY VALVE CHAMBER AIR VENT THROTTLE CATALYST</p>	<b>ENGINE TUNE-UP SPECIFICATIONS:</b> SLOW IDLE: 1050 ±100 RPM SPARK PLUG: YR7MES SPARK PLUG GAP: 0.7 to 0.8 mm FUEL: UNLEADED 91 OCTANE OR HIGHER ENGINE OIL: 15W-50, API SL GRADE

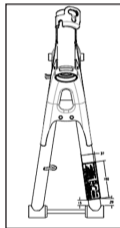

## CAUTION

It is illegal to tamper with the VIN information label as it is the only means of identifications of the motorcycle.

## ENGINE NUMBER - DETAILS

Identification of the engine serial number and its production details. It is illegal to tamper with the engine number as it is the only means of identifications of the engine.

	<b>F</b>	<b>A</b>	<b>P</b>	<b>20</b>	<b>X</b>	<b>X</b>	<b>X</b>	<b>3</b>	<b>XXXXXX</b>
Engine Family	_____	_____	_____	_____	_____	_____	_____	_____	_____
Engine Capacity	_____	_____	_____	_____	_____	_____	_____	_____	_____
Type of Cooling	_____	_____	_____	_____	_____	_____	_____	_____	_____
Type of Transmission	_____	_____	_____	_____	_____	_____	_____	_____	_____
Type of Fuel system	_____	_____	_____	_____	_____	_____	_____	_____	_____
Production Month (A-Jan., H- Aug., K- Sep., N-Dec.)	_____	_____	_____	_____	_____	_____	_____	_____	_____
Year of Manufacturing (2020:L, 2021:M, 2022:N)	_____	_____	_____	_____	_____	_____	_____	_____	_____
Manufacturing Plant (1-Oragadam, 2-Vallam Vadagal)	_____	_____	_____	_____	_____	_____	_____	_____	_____
Production Serial Nos.	_____	_____	_____	_____	_____	_____	_____	_____	_____

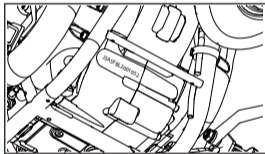

---

## **MOTORCYCLE IDENTIFICATION LABELS AND LOCATION**

---

Scan the QR code to view the labels and its location on your motorcycle.

## LOCATION OF KEYPARTS

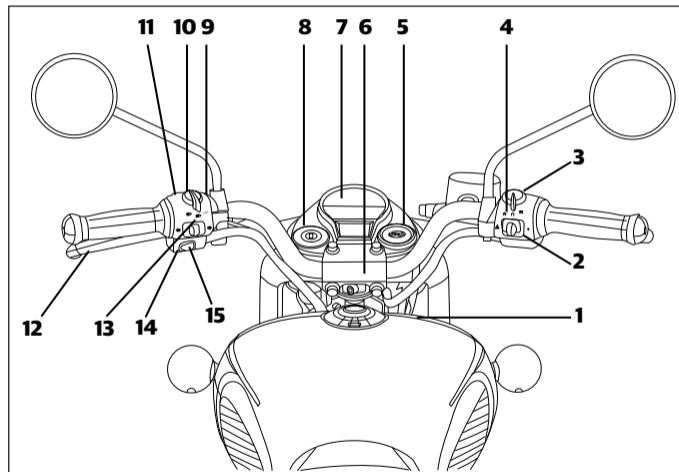

1. Fuel tank cap
2. Hazard switch
3. Engine kill switch
4. Electric start switch
5. Tripper or badge (if fitted)
6. Handle bar
7. Instrument cluster
8. Ignition switch
9. Day flash switch
10. High beam/low beam switch
11. Info button
12. Clutch lever
13. Turn signal switch
14. Charger port
15. Horn button

## LOCATION OF KEYPARTS

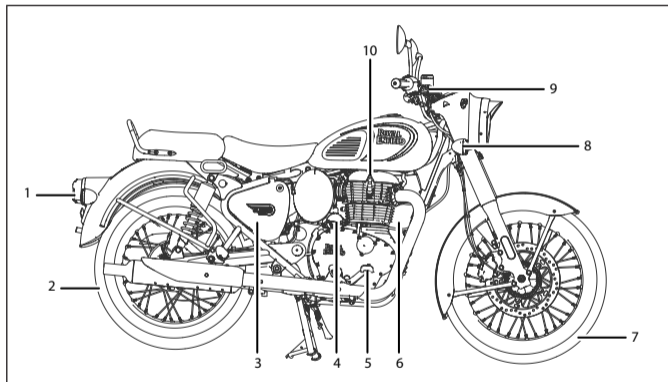

1. Right trafficator rear
2. Rear wheel
3. Right side panel
4. Starter motor
5. Brake pedal
6. Horn
7. Front wheel
8. Right trafficator front
9. Brake lever front
10. Spark plug

## LOCATION OF KEYPARTS

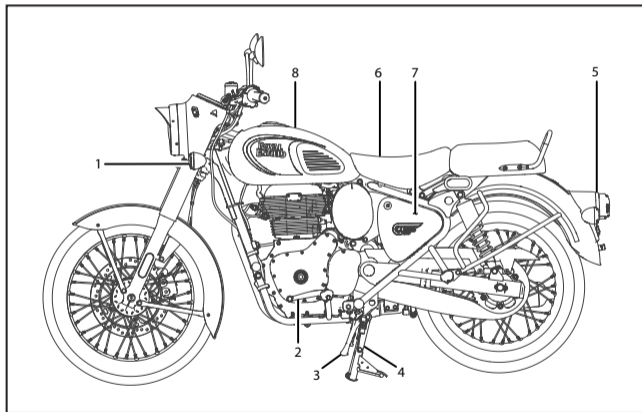

1. Left trafficator front
2. Gear change pedal
3. Side stand
4. Center stand
5. Left trafficator rear
6. Seat
7. Left side panel
8. Fuel tank

---

## OPERATION OF CONTROLS

---

### IGNITION SWITCH

---

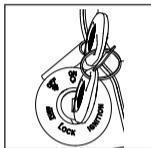

- Turn the key in the clockwise direction to unlock the steering.

### STEERING LOCK

---

- Turn the handle bar to extreme left position.
- Push the key inside in "OFF" position, press and further turn to anticlockwise direction to lock the steering system.

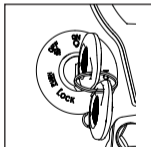

### FUEL TANK CAP

---

- Turn key clockwise to open.
- Press cap to lock with key in position.

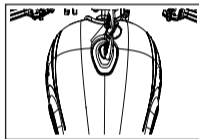



---

## OPERATION OF CONTROLS

---



### WARNING

---

- Do not overfill the fuel tank.
- Fill fuel only till the bottom of anti splash plate.
- Over filling may result in gasoline entering the EVAP canister and may damage the Evaporative Emission System.

---

### CAUTION

---

Gasoline vapour is highly explosive. Please ensure there are no open flames or sparks nearby while refuelling and fill fuel only in a well ventilated area.

Please ensure gasoline does not spill on painted surfaces. In case fuel spills over the painted surfaces wipe it off immediately as it may leave a permanent stain.

Do not smoke while refuelling or when fuel tank cap is open.

---

### FUEL TANK

---

1. Fuel tank mouth
2. Splash arrestor
3. Maximum fuel level

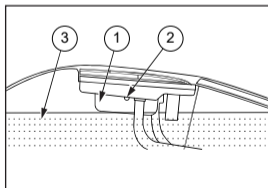

---

## OPERATION OF CONTROLS

---



### WARNING

---

Do not overfill the fuel tank. Full upto maximum fuel level & stop filling when the fuel reaches the bottom of splash arrestor. Failure to do so will lead to canister damage or can cause fuel spill out of fuel tank.

Petrol is highly explosive. Please ensure there are no open flames or sparks nearby while refuelling and fill fuel tank only in a well ventilated area.

Please ensure petrol does not spill on painted surfaces. Wipe immediately incase fuel spills over as otherwise it will leave a permanent stain on the painted surfaces.

---

### ENGINE STOP SWITCH

---



Engine "OFF"



Engine "ON"

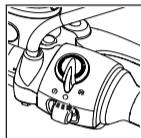

---

### E-START SWITCH

---



Push & hold till engine starts.

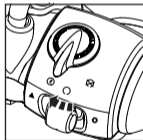

---

### CAUTION

---

- In case of prolonged stoppage of vehicle, please turn off ignition key to avoid discharge of battery.

---

# OPERATION OF CONTROLS

---

## DIGITAL INSTRUMENT CLUSTER

---

1. Digital display with analog speedometer with 3D trim ring
2. Speedo indication with stepper motor
3. Round segmented floating LCD
4. 8 - LED based tell tales
5. Display features
6. Odometer
7. Trip A and Trip B
8. Trip F
9. Fuel bar graph
10. Gear indication
11. ECO mode
12. Service reminder
13. Clock

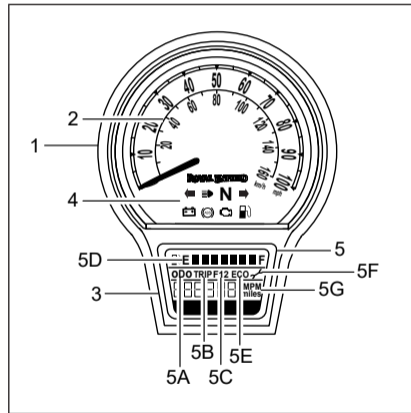

---

# OPERATION OF CONTROLS

---

## LCD FEATURES

---

### ■ Fuel gauge:

- Digital with 7 segment bar graph.
- Last segment blinking along with low fuel tell tale "ON" for low fuel condition.

### ■ Service Reminder:

- In case service reminder symbol is "ON" please plan for a scheduled service at an authorized service centre.

### ■ Trip F :

- Distance driven after low fuel tell tale is "ON"
- Cannot be re-set
- Will be visible only when low fuel condition

is sensed, will vanish if fuel is filled above low fuel condition.

- Display can be toggled using info button during this condition but will auto appear after 25 s Linked with stand switch to avoid re-set when in side stand condition.
- If ridden > 200 km in Trip F condition "Low fuel" will flash continuously on LCD. It is recommended not to ride vehicle in these condition as it will result in fuel damage.

### ■ ECO Mode

- Indicated when driven under optimum conditions.

# OPERATION OF CONTROLS

## INFO BOTTON MANAGEMENT DETAILS

- A. LCD SEQUENCE  
(Info switch  
press <1 s):-  
If Trip F enabled.

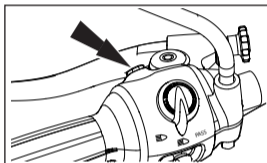

If Trip F not enabled.

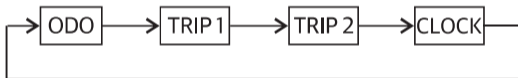
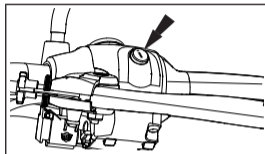

## NOTE

- For trip re-set press info button for  $T > 3$  s.

---

## OPERATION OF CONTROLS

---

### Trip A and Trip B reset:

---

Trip A mode	Press info switch	t>3	Reset Trip A
Trip B mode	Press info switch	t>3	Reset Trip B

### Trip F Condition

---

- Trip F will update only when kill switch is in "ON" condition.
- After fuel filling above reserve level Trip F will continue to show for few mins which is a normal behaviour, this is to avoid wrong indication.
- Trip F reset may occur when riding in mid

to rough roads conditions due to frequent fuel oscillations, this feature to be used for reference purpose only and on smooth road surfaces.

- Trip F will update only when side stand is removed.

### Fuel Indication

---

- Fuel indication may vary on rough road, uphill and downhill conditions, for accurate indication refer during slow speed or flat surfaces.

---

## OPERATION OF CONTROLS

---

■ Clock Setting mode:

Function	Switch	Pressure time (s)	Action
Clock Setting	info	$t > 3$	In Ign Key ON and Clock mode with no speed input (safety) press info button for specified time to enter into clock setting mode (hours will blink)
	info	$0.2 < t < 1$	Hours to increment
	info	$t > 3$	Enter into minutes mode (minutes to blink)
	info	$0.2 < t < 1$	Minutes to increment
	info	$t > 3$	Enter into unit mode (AM/PM) to blink
	info	$0.2 < t < 1$	Toggle between AM or PM
	info	$t > 3$	Save data and exit clock setting mode

---

## OPERATION OF CONTROLS - TRIPPER

---

### TRIPPER

---

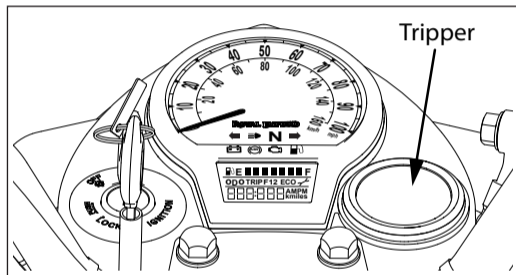

Tripper is being provided to have turn by turn Navigation on motorcycle to help riders to have a hassle free riding without handling the smartphones, This device works

based on Bluetooth connectivity with navigation search based on RE Mobile app with the support of Google maps.

Device is capable of showing turn by turn navigation on a custom designed round color TFT with uniquely designed arrow font designed intuitively for ease of riding.

Background display can be switched between day mode and night mode which can be selected by riders from RE Mobileapp.





---

## OPERATION OF CONTROLS - TRIPPER

---

### Features:

- Turn by turn navigation with primary turn, secondary turn.
- Distance to next turn, distance to destination or Estimated Time of Arrival (ETA).
- Clock display (in case of no connectivity, no navigation input or after destination is reached).
- User can select day and night mode (through RE mobile app only).
- Mobile phone low battery indication.

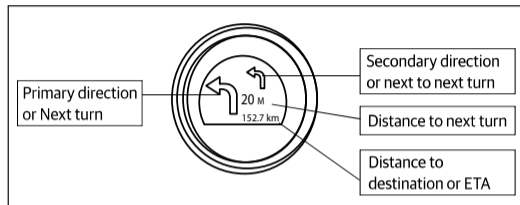

---

### DISCLAIMER

---

Tripper unit display may look dull during sun overhead conditions this is normal and due to impact of direct sunlight on the unit customers to refer during other riding conditions.

---

## **OPERATION OF CONTROLS - TRIPPER**

---

- Primary direction or next turn; Indicates the next turn to be taken along with the distance.
- Distance to next turn: Shows the distance to next turn.
- Secondary direction or next to next turn: Indicates the next turn to be taken after the primary direction, will be shown only when primary turn is less than 100 m, if there is no turn the display will be blank in this region.
- Distance to destination or ETA: Shows the total distance to destination or estimated time of arrival (based on used selection from RE Mobile app).

### **Smartphones compatible version to use RE Mobile app:**

- Compatible with Android and iOS.
- Android Support : Current version (-2).
- iOS support : Current version (-1).
- Connectivity control only through RE Mobile app.

# OPERATION OF CONTROLS - TRIPPER

## TRIPPER - DISPLAY FLOW SEQUENCE

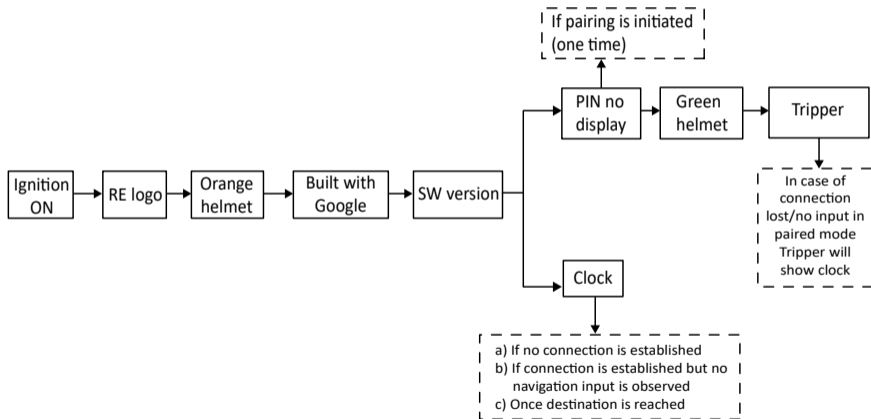

---

## OPERATION OF CONTROLS - TRIPPER

---

### NOTE

---

- After every Ignition "ON" cycle tripper will be in discoverable mode for 120 sec.
- In case there is no connection established within 120 sec display will enter into clock mode, to re-initiate connection Ignition "OFF-ON" cycle to be repeated.
- During navigation mode if there is no input from smartphone for 5 sec, bluetooth connection will be terminated to avoid power draw and will display clock.
- Bluetooth connection can be terminated by end user also by closing the mobile application.
- For first time pairing user needs to enter the secured pin shown on tripper through RE Mobile app to setup the device, after that auto-pairing will happen if same device is connected.
- Everytime the tripper is paired the clock time will sync with mobile time after which it will continue to run with internal clock even in case of disconnection, there will be time difference between time shown on instrument cluster and tripper - customer needs to update cluster clock inline with time shown on tripper as and when required as mentioned in push button management of cluster.
- Do not apply or use gasoline/petrol related fluids for cleaning or wiping on instrument cluster or Tripper as it may result in permanent damage to the same.

---

## **OPERATION OF CONTROLS - TRIPPER**

---

### **CAUTION**

---

- Ensure ignition is "ON" and display is in powered while establishing connection.
- Ensure first time pairing is done in isolated environment to avoid cross connections (one time).
- Day and night mode is user selectable only, will not change over automatically to be selected during night driving to avoid rider distraction.
- Bluetooth connection can be established only through RE Mobile app.
- Ensure bluetooth and location settings are turned always "ON" before usage.
- Disable battery optimisation settings/low battery cut-off setting of smartphone for navigation to work in low battery mode.
- RE Mobile app works only with Android (Current version 2)) and iOS (Current version 1) versions, for other lower versions performance lag can be expected.
- Tripper bluetooth version is V4.2.
- RE Mobile app works with bluetooth version 4.2 and N+1.0, for other lower versions performance lag can be expected.
- Check for network signal strength in case of navigation lag.
- Check for data speed in case of navigation lag, navigation system performance is better in 4G band compared to other lower versions.
- Calibrate mobile phones frequently for more GPS accuracy & location accuracy is dependent on.

---

## OPERATION OF CONTROLS

---

### CHARGER PORT

---

Charger port is located on left side handle bar beneath the turn signal switch.

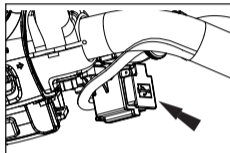

### WARNING

---

- Recommended not to use in rainy conditions to avoid damages to smart phones and charger, RE shall not be liable for any damage to smart phones.

- Do not use any other device other than mobile phones, only one mobile shall be charged at one point of time.
- Ensure proper insertion of USB cable, damages due to hard/wrong insertion of cable will not be entertained in warranty.
- Do not leave the USB port cap partially opened/closed to avoid any short circuit when not in use.
- Do not insert any metal or conductive materials inside USB charging port which may lead to short circuit.

---

## **OPERATION OF CONTROLS**

---

---

### **NOTE**

---

- Charging port is provided only for charging purpose and no data transfer is enabled.
- Provided is only constant charging mode, fast/dash charging is not provided to be compatible with multiple make mobile phones and cannot be compared with performance of original smart phone chargers.
- Duration of charging can be higher and will vary for different make mobile phones depending on smart phone battery capacity, SOC and smart phone charging circuits.

---

### **CAUTION**

---

- Customer to ensure USB port cap is closed and locked properly when not in use, warranty will not be provided if port cap is damaged and not sealed properly.
- If high current draw greater than 2.5 A is observed USB charger will shutdown please check your smart phone battery current ratings before using.
- USB charger will function only when engine is in running condition.
- Use standard approved and high quality USB cables for proper functioning.

---

## WARNING INDICATIONS AND SAFETY SYSTEMS

---

### ANTI-LOCK BRAKING SYSTEM (ABS)

---

Anti-Lock Braking System (ABS) will help prevent the brakes from locking the wheels, during sudden application of the brakes at high speeds or at low friction surfaces. This will

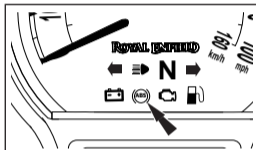

help the rider to have better traction and control over the motorcycle and prevent the motorcycle from skidding which can cause an accident.

in the event of a sudden and hard application of the brakes by the rider, the sensors in the braking system will signal the ABS modulator to momentarily and continuously reduce the hydraulic pressure and thereby prevent the brakes from locking the wheels

while reducing the speed of the vehicle. This will help the rider to control the motorcycle.

An ABS indicator lamp is provided in the cluster (as shown in the adjacent image) to warn the rider in the event of any malfunction of the ABS.

When the ignition and engine kill switch are switched in "ON" position the ABS sign will glow and remain "ON" till the motorcycle attains a speed of 5 kmph and turns "OFF". This indicates the ABS is functioning properly. If the ABS indicator lamp does not switch "OFF" and remains continuously "ON" at higher speeds, it is recommended not to drive the ABS motorcycle. Get the brake system inspected and corrected through a nearest authorised Royal Enfield Service Centre. Failure to do so can result in a serious injuries and loss of life.



---

## **WARNING INDICATIONS AND SAFETY SYSTEMS**

---

---

### **CAUTION (ABS)**

---

ABS is a safety feature to help prevent locking of wheels during panic application of brakes. It is by no means a substitute for good riding practices and anticipatory braking.

Please ride carefully and apply brakes cautiously, especially while cornering. ABS cannot estimate the "weight shifts" and momentum of the motorcycle while negotiating a corner and therefore prevent skidding due to loss of traction.

Please anticipate the stopping distance required for the speed of travel and apply brakes well in advance so as to bring the motorcycle to a safe stop.

Ensure instrument cluster is in proper functioning as it is an integral part of ABS system.

Please apply both brakes simultaneously to stop with better traction and control of the motorcycle.

Failure to adhere to the above can cause an accident resulting in serious injuries and loss of life.

---

## WARNING INDICATIONS AND SAFETY SYSTEMS

---



### WARNING

---

- Always use the approved front /rear tyres and sprockets by Royal Enfield to ensure correct ABS operation.
- Do not make any changes to the suspension travel.
- Only use recommended spare parts on the brake system which have been approved by Royal Enfield.
- ABS does not reduce braking distance. In certain circumstances, ABS may result in a longer stopping distance.

### CAUTION (ABS)

---

- Visually inspect for damaged teeth on the front and rear ABS tone rings.
- Inspect for damages and dents on the face of the teeth.
- The teeth edges should be consistent in appearance. In case if a toner ring is found to be damaged or bent, it is recommended to visit nearest dealership for necessary action.
- Inspect for debris at the end of the wheel speed sensors - front & rear, if contamination is observed, it is recommended to clear it suitably or you may visit to nearest dealership for necessary action.

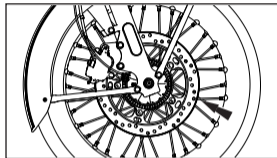

---

## **WARNING INDICATIONS AND SAFETY SYSTEMS**

---

### **DO'S AND DON'T'S: (ABS)**

---

<b>DO'S</b>	<b>DON'T'S</b>
<ul style="list-style-type: none"><li>■ While starting the engine do check the ABS indicator glows "ON" and turns "OFF" when the vehicle speed exceeds 5 kmph.</li><li>■ Please check the brake fluid at "MAX" level in the front and rear brake reservoir and ensure there is no leak in the brake systems.</li><li>■ Apply both the brakes simultaneously for better efficiency.</li><li>■ In the event of the ABS indicator remaining continuously "ON", please take the motorcycle to a nearest authorised Royal Enfield Service Centre to inspect the brake system.</li></ul>	<ul style="list-style-type: none"><li>■ Do not release the brake lever / pedal when pulsations are felt during hard application of the brakes in an emergency situation. The pulsations only indicate that the ABS is activated.</li><li>■ Do not apply only the front or rear brake as it can lead to inefficient braking.</li></ul>

---

## **WARNING INDICATIONS AND SAFETY SYSTEMS**

---

### **ROLL OVER SENSOR**

---

In the event of motorcycle falling over on either of its sides with the engine running and the gears engaged the roll over sensor will "disable" both the ignition and fuel systems and switch "OFF" the engine. This is to prevent any damage to the motorcycle and its rider. To reset the roll over sensor and reactivate ignition and fuel systems.

- Ensure the motorcycle is made upright and is on its center stand.
- Ensure gears are in correct neutral and the neutral lamp is glowing in the instrument console.

- Switch "OFF" both ignition & stop switches, wait for a few seconds and switch "ON" the Ignition and stop switch again, to start the engine.

---

## PRE OPERATIONAL CHECKS

---

A careful check of the following must be carried out every time before riding and specially after long periods of storage to determine if any additional maintenance is necessary.

1. Adequate fuel in the tank.
2. Tyres for correct pressure, abrasions or cuts.
3. Rear chain for proper tension and sufficient lubrication.
4. Brakes, steering and throttle for proper responsiveness.
5. Cable for fraying or crimping and free operation.
6. Engine oil level.
7. Alloy wheels for proper tightness.
8. Headlamp, tail lamp, brake lamp and indicator lamps for proper functioning.
9. Smooth operation and free play in front and rear brake levers.
10. Brake fluid level is above the "MIN" mark in the master cylinder.
11. Ensure the clutch free play and clutch function.



---

### **WARNING**

---

For your personal welfare and safety, all the points mentioned above should be performed periodically. Failure to do so may affect safe operation, damage your motorcycle and could result in an accident causing serious injury.

---

## RUNNING IN PERIOD

---

The Royal Enfield motorcycle as you would be experiencing is capable of consistent high speeds. However as with any new motorcycle, a "Running-In" procedure is essential to help in proper "Bedding-In" of the various moving parts in your motorcycle and to achieve optimum performance like gear shifting subsequently.

1. Do not exceed maximum specified pay load.
2. Warm up the engine for a few minutes at idling speed to allow engine oil to lubricate all the moving parts in the engine before riding the motorcycle.
3. Avoid full throttle operation and do not ride at constant throttle continuously. Vary the speed by 10% while riding.

4. Ride at proper speed and avoid sudden accelerations and braking.
5. Avoid riding motorcycle continuously for over an hour, it is recommended to take brief stop.

---

### NOTE



---

During the running-in period, do not exceed following speed limits.

Gear	Motorcycle speed	
	First 500 km	501 - 2,000 km
1	20 kmph	25 kmph
2	30 kmph	35 kmph
3	45 kmph	50 kmph
4	60 kmph	65 kmph
5	70 kmph	80 kmph

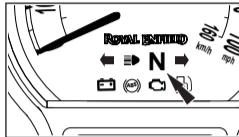
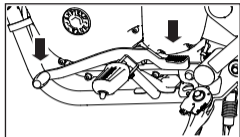
## STARTING



- To shift into neutral, move the motorcycle back and forth gently, while simultaneously shifting the gear. Ensure gear is in neutral position and the neutral lamp is glowing in the instrument cluster.
- Turn ignition key to "ON" position and engine kill switch on right hand side handle bar to "RUN" position .
- When both the ignition and engine kill switch is in "ON"  position and

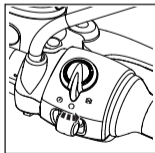

after the vehicle is started, the MIL will glow for a few seconds and turns "OFF", this indicates that all the function of the electronic fuel injection (EFI) system is functioning normally. In the event of any malfunction in the EFI system the MIL will glow continuously.

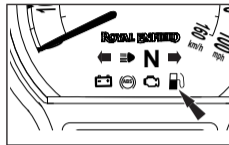

# STARTING

## CAUTION

- In case the malfunction indicator Does not turn "OFF", get the motorcycle checked through an Royal Enfield Authorised Service Centre for rectification.
- Check the fuel level indicator in the cluster for adequate fuel in the fuel tank. In case the last bar is blinking continuously, it indicates low fuel level in the tank. Please re-fuel immediately.
- Don't run the vehicle in low fuel condition in longer duration, which may damage the fuel pump.

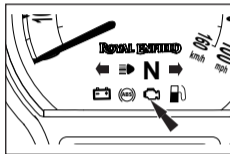

- Disengage clutch by pulling in the clutch lever and hold it in depressed condition.
- Push and hold electric start switch until engine starts for a maximum of 5 sec.

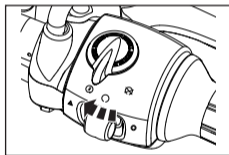
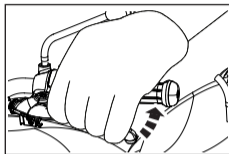



---

## **STARTING**

---

### **NOTE**

In case the engine does not start within 5 sec, release starter switch and wait for about 5 sec before attempting to start the engine again.

In case vehicle not starting on multiple continuous attempts, please turn "OFF" and turn "ON" ignition switch and then start again.

---

### **PRECAUTIONS**

---

- Vehicle may start with side stand in on condition but will turn-off when gear is engaged, this side stand cut-off feature is provided for rider safety.
- Ensure side stand is removed before vehicle moving/ starting.

---

### **CAUTION**

---

- If the engine does not start. Do not hold the starter switch in depressed condition for long periods, this will cause the battery to drain below the threshold level of 10V. Please get the motorcycle checked through an Royal Enfield Authorised Service Centre to identify and correct the reason for not starting.
- Never accelerate as soon as the engine starts, especially in cold condition. The engine should be allowed to run in idle rpm for at least 120 sec for the engine oil to circulate and lubricate all the internal moving parts and for the engine temperature to raise. Failure to adhere to this important

---

## STARTING

---

information will cause serious damage to the engine internals.

- Accelerate only after the idling rpm has stabilised and it is consistent.
- Ensure side stand is in fully retracted position. Failure to do so will cause the engine to switch "OFF" as soon as gear is engaged.



---

### WARNING

---

Please exercise extreme care while riding the motorcycle. Failure to do so can result in an accident causing injury to you or to other road users/passersby.

- Ensure gear in neutral position and the Neutral lamp is glowing in the speedometer. To shift into neutral, move the motorcycle back and forth gently, while simultaneously shifting the gear.

---

### CAUTION

---

Do not attempt to shift gears without moving the motorcycle back and forth as it will damage the gears mechanism.

---

## STARTING

---

- Depress and hold the clutch Lever.

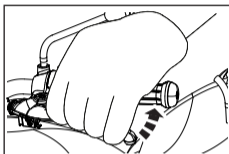

- Press starter button and hold till engine starts. Do not release the button before engine starts.
- Do not press the starter button more than 5 sec After three successive cranking, wait for 15 to 20 sec the battery to recover.

---

## GEAR SHIFTING, RIDING AND STOPPING

---

- Warm up engine for 2 minutes - till idling is consistent/stable.

### GEAR SHIFT PATTERN

1 -- N -- 2 -- 3 -- 4 -- 5

- Press clutch lever towards the hand grip.
- Press gear pedal with toe towards down to engage 1<sup>st</sup> gear.
- Gently open throttle and release clutch simultaneously. If clutch is released suddenly, the engine may stall and cause a jerky start.
- It is recommended to use half clutch condition when commuting in the city traffic condition alone (Engine rpm around idling to 2000 rpm) at 1<sup>st</sup> gear condition. In other gears and higher rpm avoid using half clutch which will proportionately reduce

the clutch life. During acceleration/deceleration disengage the clutch completely, shift the gear and engage the clutch.

---

### CAUTION

---

The clutch must be fully disengaged before attempting a gear shift. Failure to fully disengage the clutch may cause a jerky start or stalling

the engine besides causing damage to transmission parts.

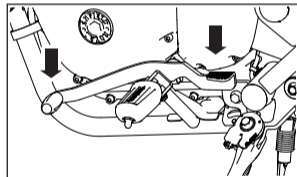

---

## GEAR SHIFTING, RIDING AND STOPPING

---

- Press the gear pedal either upward with toe or downward with heel to engage 2<sup>nd</sup> gear.
- Follow the same procedure for 3<sup>rd</sup>, 4<sup>th</sup> and 5<sup>th</sup> gear.

---

### NOTE

---

Always start motorcycle with gear in neutral position.

Always move the motorcycle in first gear position only.

When engine speed decreases or while climbing a gradient or running at a reduced speed, shift to the appropriate lower gear to prevent the engine from stalling or straining to pull.

The clutch lever must be fully depressed before attempting

a gear shift. Failure to fully depress the clutch lever will cause a rough start or stalling of the engine besides causing damage to transmission parts.

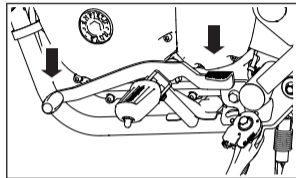

- When the vehicle is in neutral position, press gear shift lever down with toe to engage 1<sup>st</sup> gear.

### GEAR SHIFT PATTERN

1 -- N -- 2 -- 3 -- 4 -- 5

---

## GEAR SHIFTING, RIDING AND STOPPING

---

Shift	Gears	Vehicle Speed (kmph)
Up Shift	1 <sup>st</sup> - 2 <sup>nd</sup>	24
	2 <sup>nd</sup> - 3 <sup>rd</sup>	38
	3 <sup>rd</sup> - 4 <sup>th</sup>	50
	4 <sup>th</sup> - 5 <sup>th</sup>	63
Down Shift	5 <sup>th</sup> - 4 <sup>th</sup>	50
	4 <sup>th</sup> - 3 <sup>rd</sup>	38
	3 <sup>rd</sup> - 2 <sup>nd</sup>	24
	2 <sup>nd</sup> - 1 <sup>st</sup>	13

---

### CAUTION

---

- If the clutch lever is released abruptly and throttle opening is done insufficiently the motorcycle will have rough start and cause the engine to stall.
- If the acceleration is very high and clutch lever is released abruptly, it will cause motorcycle to move suddenly, which will lead to loss of control leading to an accident resulting in injury and or loss of life to rider/other road users/passed by besides damage to the motorcycle.

---

## GEAR SHIFTING, RIDING AND STOPPING

---

- Always exercise utmost caution while releasing clutch and riding the motorcycle.
- Press the gear pedal either upward with toe or downward with heel to shift subsequent gears.
- Always shift to lower gears as appropriate whenever slowing down to stop the vehicle.
- Shift gears to neutral position just before bringing the vehicle to a complete stop always.

---

### NOTE

---

Always start motorcycle with the gear in neutral position.

When the engine speed decreases or while climbing a gradient or running at a reduced speed, shift to the appropriate lower gear to prevent the engine from stalling or straining to pull.

- Close throttle fully and release the clutch lever slowly ensuring the motorcycle is in neutral position and neutral lamp is glowing.
- Stop the motorcycle in a safe place, turn "OFF" ignition and switch "OFF" engine kill switch.

# PARKING

## PARKING MOTORCYCLE ON CENTER STAND

- Select a firm, flat surface.
- Hold handle bar straight.
- Lower center stand and ensure that both the legs of the stand are resting evenly on firm ground.
- Apply pressure on the fulcrum lever on the center stand and pull motorcycle backwards, gently.

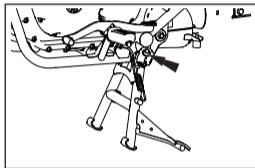

## PARKING MOTORCYCLE ON SIDE STAND

- Select a firm, flat surface.
- Lower side stand and gently tilt motorcycle to the left till it rests firmly.

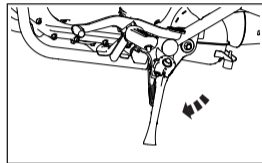

### WARNING

Always park the motorcycle on a firm and flat surface. Parking in a soft ground may cause stand to sink and the motorcycle to fall, causing injury to you or to others and damage to the motorcycle parts.



## TOOLS KIT

The tool kit is located in the right side panel of the motorcycle.

S.No.	Description	Qty.
1	Allen key 6 mm	1
2	Fuse puller	1
3	Tool spark plug (8x16 Box Spanner)	1
4	Ring spanner 24x14-24 (Eye wrench) x 14 (open end) Combination	1
5	Open end spanner 17 x 13	1
6	D/E Spanner 10 x 12	1
7	Screw driver 06 x 120/135	1
8	C-Spanner	1
9	Extension tube 28x7 & 24 x 14	1

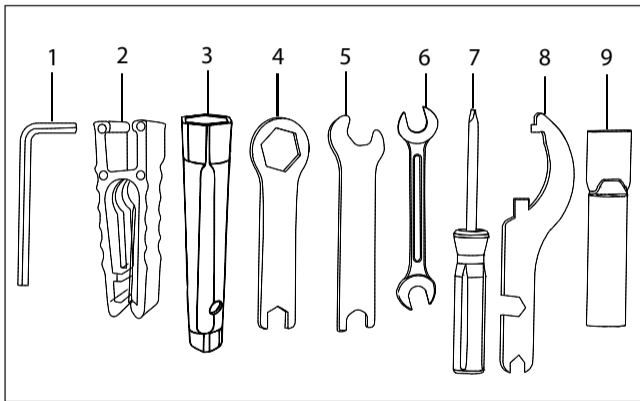

---

## MINOR MAINTENANCE TIPS

---

The following simple maintenance activities will help in maintaining your motorcycle. However for an elaborate maintenance, we recommend you to get in touch with a Royal Enfield Authorised Dealer/Service Centre.

---

### CONTROL CABLES

---

Lubricate after water washing motorcycle or if used during rainy conditions.

---

### HAND LEVER PIVOTS

---

- Wipe the area free of dirt/grease.
- Apply a few drops of oil on the pivots.

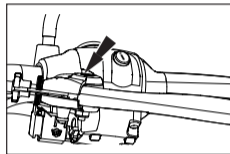

---

### CENTER/SIDE STAND PIVOTS

---

- Apply a few drops of oil on the pivots after cleaning the area of dirt.

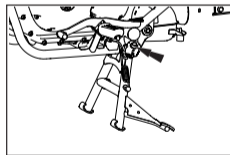

---

## MINOR MAINTENANCE TIPS

---

### OIL LEVEL INSPECTION

---

- Ensure vehicle is in center stand.
- Switch on the engine and gently raise the rpm for 10 sec.
- Leave the vehicle in idling condition for 15 sec.
- Switch off the engine & wait for the oil to settle down (approx 60 sec).
- Engine oil level should be "Max" level.

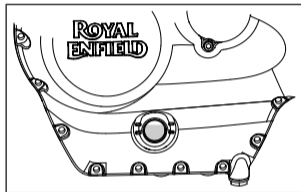

- In case of oil level is not as max condition, then top up oil to "Max" condition and repeat the procedure as mentioned above.
- Always use recommended engine oil only.

---

### CAUTION

---

- Use of wrong grade or spurious oil can seriously affect motorcycle performance & damage to moving parts.
- Do not check the engine oil level in cold condition.
- Do not sit on the vehicle while engine oil inspection.
- Do not inspect the oil level window immediately working up allow it to settle properly.
- Do not overfill the engine oil above "Max".

---

## MINOR MAINTENANCE TIPS

---

### DRIVE CHAIN

---

Clean the drive chain carefully. Apply chain lubricant while simultaneously rotating the rear wheel. Wipe off the excess lubricant.

- Ensure the motorcycle is in upright on a firm and flat surface.
- Hold the spindle from the LH with a screw driver and loosen the spindle nut with a 24mm ring spanner and loosen the LH & RH chain adjuster by using 6 mm allen key.

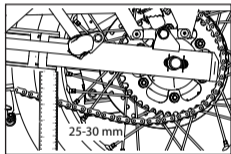

- Align the line mark in the adjuster and swing arm in both the sides & set the drive chain free play for 25 to 30mm by using steel rule.
- Tighten the LH & RH chain adjusters in the swing arm using a 6 mm allen key.
- Tighten the spindle nut fully.
- Ensure the chain tension should be 25 to 30mm using a ruler/scale.



---

### WARNING

---

Chain slackness beyond 30mm will lead to chain slippage.

Maintain drive chain slackness within the specified limits at every 500km interval.

Please check the front and rear wheels are correctly aligned, after the chain adjustment.

---

## **MINOR MAINTENANCE TIPS**

---

---

### **SPARK PLUG**

---

---

#### **CLEANING AND ADJUSTING PLUG CAP**

---

- Remove the spark plug cap from the spark plug.
- Remove spark plug using the plug spanner and tommy bar.
- Clean the insulator tip and electrodes of the plug carefully.
- Check and set the electrode gap between 0.70 to 0.80mm.
- Refit the spark plug on the cylinder head and refit the spark plug cap on the spark plug.

---

### **CAUTION**

---

- Ensure ignition & kill switch are in off condition before accessing the spark plug.
- Before opening the spark plug blow away the dust in surrounding area to prevent it falling inside cylinder head.
- Ensure spark plug is being replaced with recommended specification only.

---

## MINOR MAINTENANCE TIPS

---

### CHECKING BRAKE FLUID

---

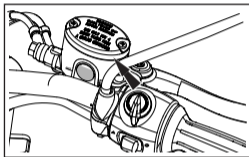

#### Front Brake

Place your motorcycle in an upright position on a firm, level surface.

**Front :** Check that the brake fluid reservoir is horizontal and that the fluid level is above middle of the oil window. Oil window middle to be considered as "Min" mark.

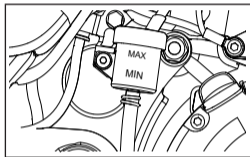

#### Rear Brake

**Rear :** Check that the brake fluid reservoir is horizontal and that the fluid level is between the "Max" level and "Min" level marks.

---

### CAUTION

---

Brake fluid is highly corrosive and can cause damage to painted parts. Please ensure that brake fluid does not spill on any part of the motorcycle. In the event of a spill, please clean the area immediately with a soft cloth (preferably a wet cloth) to avoid damage.

Do not mix Dot 4.

---

## MINOR MAINTENANCE TIPS

---

### NOTE

---

- Clean the filler cap before removing. Use only Dot 4 brake fluid from sealer container.
- Use only the specified brake fluid; otherwise, the rubber seals may deteriorate, causing leakage.
- Refill with the same type of brake fluid. Adding a brake fluid other than Dot 4 may result in a harmful chemical reaction.
- Be careful that water or dust does not enter the brake fluid reservoir when refilling. Water will significantly lower the boiling point of the fluid and may result in vapor lock and dirt may clog the ABS hydraulic unit valves.



### WARNING

---

- An insufficient brake fluid level will cause the brake system to fail.
- Old brake fluid reduces the braking effect.
- Make sure that brake fluid for the front and rear brake is changed in accordance with the periodic maintenance schedule.
- Keep brake fluid out of the reach of children.
- Do not allow brake fluid to come into contact with the skin, the eyes or clothing.
- Brake fluid is highly corrosive and can cause damage to painted parts. Ensure brake fluid does not spill on any part of the motorcycle, in the event of spill please clean the area immediately with a soft cloth to avoid damage.

## MINOR MAINTENANCE TIPS

### INSPECTION OF TYRES AND WHEELS

- Inspect the tyres periodically for tread wear, cracks and cuts.

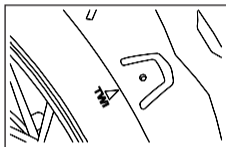

Minimum tread depth :

Front and rear tyre : 0.8mm

- Check and remove stone, splinters, nails or other particles embedded in the tyre treads.
- Periodically inspect wheels for spokes breakage and wheel rim run out.
- Check proper seating of the tyre beading on the rim whenever the tyre is reassembled.

- Use only recommended tyres & tubes, inflated to correct air pressure.

	Front	Rear
Solo	32 psi	32 psi
With pillion	32 psi	36 psi



### WARNING

- It is recommended to operate the motorcycle with correct tyre pressure as under inflated tyres may cause tyre to overheat and may result in tyre damage and may cause injury to the rider.
- It is recommended to use Royal Enfield recommended tyre specification in case of replacement of new tyres, it is recommended to use the same specification of the tyre recommended by Royal Enfield, failure to adhere the same may result in tyre damage and may cause injury to the rider.



---

## MINOR MAINTENANCE TIPS

---

### BRAKE PADS

---

The front and rear brake pads must be checked for wear at the intervals specified in the periodic maintenance chart.

Front : The pads need to be replaced if a brake pad is worn to the indicator.

Rear : The pads need to be replaced if a brake pad is worn to the indicator.

Royal Enfield has provided your new motorcycle with the optimum brake pad friction material available.

It gives the best performance under dry,

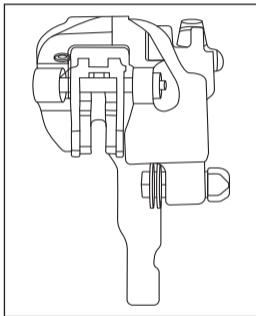

wet and high operating temperature conditions.

Please note that during some braking conditions you may experience noise, this is normal for this friction material.

- Glazed area or noise during brake application- Repair
- Sand the glazed area with coarse sand paper.

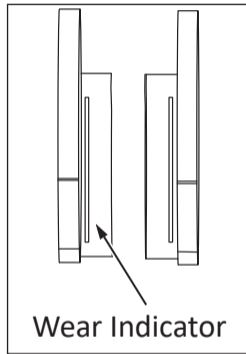

---

### NOTE

After sanding the glazed areas, clean the brake shoe with a cloth.

---

## MINOR MAINTENANCE TIPS

---

### BATTERY AND MAINTENANCE

---

- The motorcycle is provided with 12 V - 8 Ah VRLA battery.
- The battery must be periodically checked for cleanliness and corrosion free terminals.

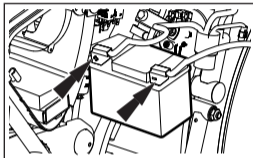

---

### NOTE

---

The poor contact or loose fittings of battery terminals may cause electrical/electronic parts failure.

### CAUTION

---

- The battery must be periodically checked for cleanliness and corrosion free terminals.
- The poor contact or loose fitment of battery terminals may cause electrical/electronic parts failure.
- Always disconnect the black negative (-ve) battery cable first and then the red positive (+ve) cable while removing the battery connections.
- For checking the battery voltage check with multimeter in voltage mode or contact Royal Enfield Authorised Service Centre or battery service center.

---

## MINOR MAINTENANCE TIPS

---

- Clean the wire terminals free from corrosion and keep the terminals coated with petroleum jelly.
- Keep the (+ve) positive terminal and (-ve) negative terminal cables firmly connected to the respective battery terminals. Failure to do so may result in damage to the motorcycle electrical system.

---

## HEADLIGHT BEAM ADJUSTMENT

---

- The headlight beam focus can be adjusted in vertical direction by using the adjusting screw by turning clockwise or anticlockwise direction.

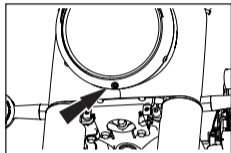

- The adjusting screw is used to increase or decrease the height of the headlight beam in vertical direction only. This may be required to increase the visibility and to help prevent the other riders/vehicles passing nearby.

---

## MINOR MAINTENANCE TIPS

---

Fuse & Fuse carrier located in RH side cover.

### EMS FUSES

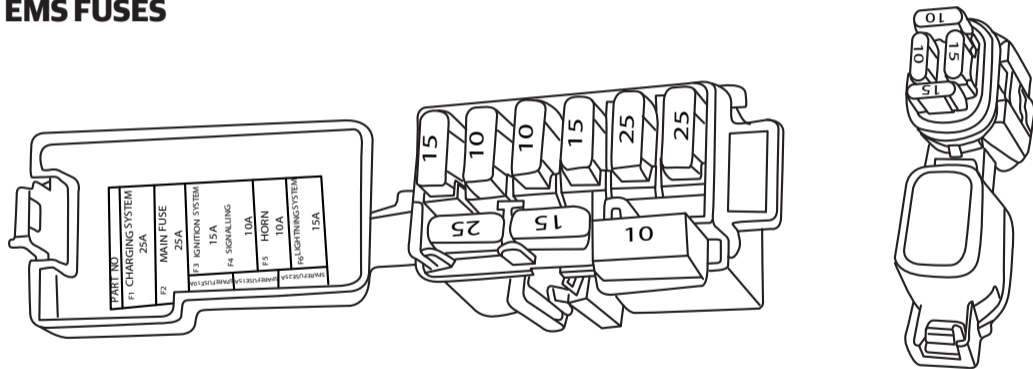

---

## MINOR MAINTENANCE TIPS

---

### MINI BLADE FUSE USAGE LIST

---

Fuse ID Number	Color	Rating	Remarks
1	WHT	25 A	Charging system
2	WHT	25 A	Main fuse
3	WHT	15 A	Ignition system
4	RED	10 A	Signaling fuse
5	RED	10 A	Horn fuse

Fuse ID Number	Color	Rating	Remarks
6	BLU	15 A	Lighting system
ABS fuse list			
7	BLU	15 A	ABS fuse
8	RED	10 A	ABS fuse



### WARNING

Please get the electrical system of your motorcycle checked thoroughly and get the faults corrected immediately after experiencing any fuse failure. Failure to do so may result in repeated fuse failure.

Usage of fuses other than specified rating or usage of any other conductive materials or low grade fuses will damage the complete electrical system

---

## REAR SUSPENSION SETTING

---

- Rest the motorcycle on center stand.
- Ensure the tyre pressure is at recommended specification.
- Ensure adjuster are clear of all dirt and debris before adjusting, if they have dirt or debris please clean it suitably before adjusting.

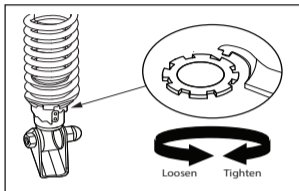

- The adjuster is a 6 step adjuster and it is kept at first notch position.
- Adjust shock preload by rotating the adjuster clockwise using C-spanner to Increase the preload.
- Adjust shock preload by rotating anti-clockwise using C-spanner to decrease preload (to make it to first notch position).
- Make the same adjustments on both sides, uneven adjustment may lead to discomfort to the rider.

## REAR SUSPENSION SETTING

### NOTE

- Adjusting the suspension requires a C-spanner. It is we recommend to use the C-spanner that is given in your vehicle tool kit. Extension tube to be used for leverage purposes.

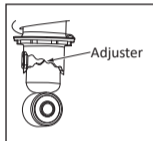

- The best spring preload setting is achieved when it is set for the weight of the rider and that of any luggage and a passenger.
- We recommend to increase the preload and keep it at final notch for fully loaded (GVW condition), thus ensuring an ideal compromise between handling and stability.

Condition	Max Reference Payload	Suspension Setting Notch	Tyre Pressure (psi)	
			Front	Rear
Unladen / One up Loading / Rider only.	Rider upto 90 kg	1st	32	32
Laden / Two up / Rider + Pillions / Rider + Pillion + Accessories	Upto a maximum of 180 kg payload (Inc of rider weight, pillion weight and accessories)	6th	32	36

\*Ensure the preload is set equally on the LH and RH rear suspension.

---

## **LONG TRIP PRECAUTIONS**

---

### **CHECKS PRIOR TO THE COMMENCEMENT OF A LONG JOURNEY**

---

- Service the motorcycle at Royal Enfield Authorised Service Centre.
- Ensure sufficient quantity of fuel is always available in the fuel tank for the journey planned.
- Check and correct tyre pressure if necessary.
- Ensure the clutch free play and clutch function.

### **CHECKS AFTER EVERY 1,000 KM OF RUN**

---

- Any loose fasteners.
- Condition of the tyres.

- Correct oil level in engine.
- Working of all lights and horn.
- Proper drive chain tension.
- Clutch cable free play.

---

### **ITEMS TO BE CARRIED**

---

- Tools kit.
- Bulbs for headlight, trafficator light and fuse.
- Accelerator and clutch cables.
- Spark plug, spark plug cap, fuel hose.



---

## WASHING PROCEDURE

---

### PRECAUTIONS

---

- Remove ignition key and seal the ignition key barrel slot using adhesive tape.
- Please remove tool kit, first aid kit and other relevant documents if any inside the right side panel before proceeding for washing of the motorcycle.
- Cover the silencer tail pipe, horn and control switches with suitable plastic bags and tie if firmly to prevent water entry.
- Wash the motorcycle only when the engine is in cold condition.
- Do not remove side panel while washing to avoid water entry.
- Brush engine area with a recommend non corrosive solvent to remove dirt or grease.
- Use low pressure water jet to clean.
- Never spray water with great force on head lamp, meter / cluster unit, flasher lights, front and rear wheel hubs, electrical connections and wires, control cables, EFI components, spark plug, battery, side panels.
- Do not use high pressure washers or steam jet cleaners near the seal of headstock bearing or steering stem bearing, seal of wheel bearing, brake calipers, air intakes & exhaust outlets.
- Do not apply any corrosive solvent on painted surfaces or rubber parts.

---

## WASHING PROCEDURE

---

- Use lukewarm water and mild detergent on the painted components to remove dirt, etc.
- Clean motorcycle thoroughly with plain water to remove the detergent.
- Never spray water towards bottom side of instrument cluster directly to avoid water entry through breather holes.
- If possible, use compressed air and blow off water particles from the obscure areas of the motorcycle, electrical connections etc.
- Once the motorcycle has been ridden in salty conditions (i.e. during winter in places where road salt is used) or near coastal areas it is recommended to wash your motorcycle with cold water after the ride to prevent corrosion or rust build-up. Please do not use warm water for washing as it may damage the motorcycle due to chemical reaction with the salt. After washing process once the motorcycle is completely dry it is recommended to apply anti corrosion spray on all the metal and chrome plated areas to protect the parts from corrosion.
- It is recommended not to apply the anti-corrosion spray on the brake discs.
- Do not use petrol, or other flammable liquids to clean or wash on electronic parts.
- The parts chosen using motorcycle configurator should not be washed with soap or chemical, use only with plain water.

---

## **WASHING PROCEDURE**

---

### **AFTER WASHING**

---

- Ensure, the motorcycle is thoroughly dry by wiping with a clean soft lint free absorbent cloth or chamois leather.
- Remove all adhesive tapes.
- Lubricate control cables, pivots for footrest, side stand, center stand, brake and gear shifter linkages, drive chain etc. with lube oil.
- Polish the painted and plated surfaces using recommended automobile polishing wax.
- Start the engine and allow to run at an idling speed for a few minutes to warm up engine.
- Drive the motorcycle slowly, apply both the brakes intermittently to dry up the water in brake pads.
- Please clean/wipe out water spills completely inside the RH side panel before keeping tool kit, first aid kit and other relevant documents inside the right side panel.

---

## STORAGE PRECAUTIONS

---

In-case your motorcycle is not going to be used for a month or more, the following precautions should be taken.

- Get the motorcycle serviced through a Royal Enfield Authorised Service Centre.
- Drain the fuel completely from the fuel tank and induction system.
- Remove spark plug, Pour in about 5 ml of clean engine oil through spark plug hole. Close the hold and crank engine several times and refit spark plug.
- Clean drive chain thoroughly and apply Royal Enfield recommended chain lubricant.
- Wipe off excess lubricant after 5min of application.
- Remove charging circuit fuse from the fuse box.
- Store the battery in a cool, dry and well ventilated place.
- Cover the silencer with suitable bags to prevent moisture entry. Set the motorcycle on its center stand.
- Apply anti rust solutions on all plated parts. Take care not to apply this solution on chrome, rubber or painted parts. Store motorcycle in a clean covered area free of moisture and dust.
- For re-use after storage, it is preferable to get the motorcycle prepared through a Royal Enfield Authorised Service Centre to ensure the motorcycle is restored to its peak operating conditions.
- Battery (+ve) connector can be disconnected to avoid battery drain issue in longterm.

---

## **ENVIRONMENT CARE**

---

### **BE AN ENVIRONMENTALLY CONSCIOUS RIDER**

---

You've ridden through some beautiful places on your Royal Enfield. Won't you like to keep them that way? Here are some tips to help you keep those places unspoilt so that others can enjoy them too:

#### **Engine Oil**

While your liquid waste like engine oil, gasoline, coolant and other cleaning solvents need to be regularly replaced, what happens to them? Make sure they are not dumped in the soil, down the sewers, drains, lakes or rivers around you. The simplest way to do it is to have them drained into a container which you can hand over to your local recycling agent or at your nearest Royal Enfield service centre. They will follow the guidelines laid down by the local authorities to get rid of it.

#### **Battery**

If your Royal Enfield's battery needs to be replaced, hand it over to an authorised recycling agent or Royal Enfield service centre. They will follow the guidelines laid down by the local authorities to get rid of it. This will ensure the dangerous substances from which the battery has been manufactured do not pollute the environment.

---

## **ENVIRONMENT CARE**

---

### **Tyre(s) / Plastic / Electrical / Electronic parts / Oil Filter**

If your Royal Enfield's tyre(s) / plastic / electrical / electronic part(s) / oil filter need to be replaced make sure you hand them over to an authorised recycling agent or a Royal Enfield service centre. They will follow the local authority's guidelines to get rid of them in an environmentally friendly manner.

### **Cleaning your Royal Enfield**

Avoid aerosol sprays : Instead, use a biodegradable detergent or dry wash to wash your Royal Enfield. Also, be cautious while discarding the cleaning solvents. Hand them over to an authorised recycling agent or a Royal Enfield service centre. They will follow the local authority's guidelines to get rid of them in an environmentally friendly manner.

---

This not does not constitute legal advice; please contact your local authorities or your nearest Royal Enfield Service Center for further guidance.

---

## PERIODICAL MAINTENANCE

---

The maintenance schedule detailed here will help you maintain your Classic 350 motorcycle meticulously and to get a long trouble free service. The schedule provided herein is based upon average riding conditions and indicates the km, at which regular inspections, adjustments, replacements and lubrications are to be carried out. The frequency of the maintenance must be shortened depending upon the severity of the driving condition or if the motorcycle is used in a very dusty environment. Contact the nearest Royal Enfield Authorised Dealer / Service Centre for expert advice and to carry out the required maintenance.

Sl. No.	DESCRIPTION	PERIODICAL MAINTENANCE										
		Km (x 1,000)	0.5	5	10	15	20	25	30	35	40	45
	Miles (x 1,000)	0.3	3	6	9	12	15	18	21	24	27	30
	Months	1.5	6	12	18	24	30	36	42	48	54	60
1	Engline oil (level check/replace)	R	I	R	I	R	I	R	I	R	I	R
		Check level at every 1,000 km or earlier and topup as required										
2	Engline oil filter element	R		R		R		R		R		R
3	Engline oil strainer on crankcase LH	C		C		C		C		C		C

## PERIODICAL MAINTENANCE

Sl. No.	DESCRIPTION	PERIODICAL MAINTENANCE										
	Km (x 1,000)	0.5	5	10	15	20	25	30	35	40	45	50
	Miles (x 1,000)	0.3	3	6	9	12	15	18	21	24	27	30
	Months	1.5	6	12	18	24	30	36	42	48	54	60
4	Inlet / exhaust tappet setting	I&A		I&A		I&A		I&A		I&A		I&A
5	Rubber hose-intake adapter	I	I	I	I	I	I	I	I	I	I	I
6	Evaporative emission equipment rubber hoses & drain the overfilled by removing plug.	I	I	I	I	I	I	I	I	R	I	I
7	Spark plug			C&A		R		C&A		R		C&A
8	HT lead for crack	I	I	I	I	I	I	I	I	I	I	I
9	Air filter element	C	C	R	C	R	C	R	C	R	C	R
		Clean/Replace more frequently if operated in dusty condition										
10	Vent pipe under air filter box	I	I	I	I	I	I	I	I	I	I	I



## PERIODICAL MAINTENANCE

Sl. No.	DESCRIPTION	PERIODICAL MAINTENANCE										
		Km (x1,000)	0.5	5	10	15	20	25	30	35	40	45
	Miles (x1,000)	0.3	3	6	9	12	15	18	21	24	27	30
	Months	1.5	6	12	18	24	30	36	42	48	54	60
11	Starter motor & starter relay connections	I	I	I	I	I	I	I	I	I	I	I
12	Battery terminals (apply petroleum jelly)	C	C	C	C	C	C	C	C	C	C	C
13	Earth wire eyelet contact					I						I
14	Injector hose	I	I	I	I	I	I	I	I	I	I	I
15	Fuel filter in fuel pump							R				
16	Front fork oil	I	I	I	I	R	I	I	I	R	I	I
17	Steering ball races play	Inspect/adjust, if required lubricate for every 5,000 km or earlier as required. Replace if necessary.										
18	Wheel rim run out front & rear	I		I		I		I		I		I

## PERIODICAL MAINTENANCE

Sl. No.	DESCRIPTION	PERIODICAL MAINTENANCE											
		Km (x 1,000)	0.5	5	10	15	20	25	30	35	40	45	50
	Miles (x 1,000)	0.3	3	6	9	12	15	18	21	24	27	30	
	Months	1.5	6	12	18	24	30	36	42	48	54	60	
19	Swing arm pivot bush & spacer	I	Inspect, if required lubricate for every 5,000 km or earlier as required. Replace if necessary.										
20	Tire wear pattern (front & rear)	I	I	I	I	I	I	I	I	I	I	I	
21	Rear wheel drive chain	Clean, lubricate every 1,000 km / clean, lubricate & adjust every 5,000 km or earlier as required											
22	Rear wheel cush drive rubbers					I&R					I&R		
23	Front & rear brake hose & banjo bolt	I	I	I	I	I	I	I	I	I	I	I	
24	Brake fluid level, front & rear disc	I	I	I	I	R	I	I	I	R	I	I	
25	Clutch lever/cable free play	Adjust every 1,000 km or earlier as required & replace if required.											

## PERIODICAL MAINTENANCE

Sl. No.	DESCRIPTION	PERIODICAL MAINTENANCE										
		Km (x1,000)	5	10	15	20	25	30	35	40	45	50
	Km (x1,000)	0.5	5	10	15	20	25	30	35	40	45	50
	Miles (x1,000)	0.3	3	6	9	12	15	18	21	24	27	30
	Months	1.5	6	12	18	24	30	36	42	48	54	60
26	Hand levers & foot levers	Lubricate every 1,000 km or earlier as required										
27	Pivot-side stand, center stand, pillion foot rest, gear shifter, brake pedal, levers	L	L	L	L	L	L	L	L	L	L	L
28	Throttle cable	Adjust every 5,000 km or earlier if required										
29	Brake pads - front & rear	I	I	I	I	I	I	I	I	I	I	I
30	Side stand switch operation	I	I	I	I	I	I	I	I	I	I	I
31	All mounting fasteners in vehicle for tightness	I	I	I	I	I	I	I	I	I	I	I

## PERIODICAL MAINTENANCE

Sl. No.	DESCRIPTION	PERIODICAL MAINTENANCE										
	Km (x 1,000)	0.5	5	10	15	20	25	30	35	40	45	50
	Miles (x 1,000)	0.3	3	6	9	12	15	18	21	24	27	30
	Months	1.5	6	12	18	24	30	36	42	48	54	60
32	Throttle body - cleaning	Throttle body should be removed from the vehicle and cleaned with a dry microfibre cloth, usage of throttle body cleaners or any similar solvent or alcohol based liquids for cleaning is strictly prohibited, Throttle body cleaning every 10,000 km/12 months or earlier as required.										

A : Adjust C : Clean D : De-carbonise I : Inspect (Clean, Adjust, Lubricate or replace if necessary) L : Lubricate R : Replace  
 The maintenance schedule detailed here will help you to maintain your Royal Enfield motorcycle meticulously and to get along trouble free service. The frequency of the maintenance must be shortened depending upon the severity of the driving condition or if the motorcycle is used in a very dusty environment. severe climatic cold and hot conditions. bad roads, stagnant water etc ., Contact a nearest Royal Enfield Authorised Dealer/ Service Centre for expert advice and to carry out the periodical maintenance.

### NOTE

For maintenance after 50,000 km, please repeat the same frequency levels specified above, in consultation with a Royal Enfield Authorised Dealer/Service Centre.

---

## **WARRANTY TERMS AND CONDITIONS**

---

Royal Enfield (RE) warrants its motorcycle to be free from manufacturing and material defect under normal use subject to following conditions.

1. Warranty shall be in force until the expiry of a period of 36 months from the first date of sale to the first customer and to any subsequent owners for the balance of the remaining period, until expiry of 36 months from the date of first sale/registration of the motorcycle.
2. In order to effect Warranty, it is a prerequisite that the maintenance schedule prescribed by Royal Enfield in this owner's manual and warranty repairs if any, has been carried out at the Authorised Distributor's service facility or at their Authorised dealership's service facility.
3. Record of all the regular services and periodical maintenance that have been carried out, along with proof of service history will be required to be verified by the Authorised Distributor's service facility or their Authorised dealership's service facility prior to carrying out a warranty service.
4. Proof of Ownership, in the form of sales registration or proof of purchase documentation of the motorcycle, clearly mentioning the engine and VIN numbers, must be provided to the Distributor's service facility or their Authorised dealership's service facility.

---

## WARRANTY TERMS AND CONDITIONS

---

5. During the warranty period, Royal Enfield's obligation is limited to repair or replacing free of charge, such part or parts of the motorcycle which in examination shall be deemed defective in the opinion of Royal Enfield and/or their distributors/authorised dealers. Such defective part(s). which has been replaced, shall become the property of Royal Enfield.
6. Cost of consumables like fuel. oils etc, labour. shipping charges of replacement parts for any warranty replacement are chargeable to the customer.
7. Warranty is not applicable for the following parts:
  - Normal ageing of parts like rubber parts, tyres and tubes, hand grips, glass, plastic, soft items like seat rexene, cushion etc.
  - Dullness of chrome plated parts. discolourisation of chromed exhaust pipe/silencer, buffed parts, painted surfaces etc.
  - Normal wear and tear items such as control cables. brake pads/shoes. clutch etc.
  - Electrical items like bulbs, wiring harness, switches, battery, fuses, electric start motor etc.

---

## WARRANTY TERMS AND CONDITIONS

---

8. Warranty will become void under the following conditions:

- Damages due to lack of proper maintenance, periodic services not carried out as per Royal Enfield recommendation etc.
- Damages caused by any unauthorised repairs carried out in any part of the motorcycle.
- Failures occurred due to use of non recommended grade lubricants, fuel or improper level.
- Use of non genuine Royal Enfield parts.
- Damages caused due to unauthorised alterations to any part of the motorcycle.
- Use of accessories not supplied by Royal Enfield.
- Motorcycle fitted with side cars.
- Motorcycle used in rallies, off road, dirt track, races etc.
- Motorcycle involved in accidents, collisions etc.
- Damages that occur due to extreme operating conditions beyond the limitation or specifications as given by Royal Enfield, such as maximum load carrying capacity, engine speed etc.
- Damages that occur due to long/ improper storage, transportation of motorcycle etc.

---

## **WARRANTY TERMS AND CONDITIONS**

---

9. Royal Enfield reserves the right to finally decide on all warranty claims.
10. Royal Enfield reserves the right to make changes in the motorcycle without any obligation to install these changes on previously sold motorcycle.
11. Royal Enfield authorised distributors and/or their dealers are independently owned and operated. They may hence deal with other aftermarket products for which Royal Enfield is not responsible for the performance, safety, quality, reliability and suitability of such products. defects, if any in such parts or that may arise in the motorcycle due to use of such parts is not liable to be covered by Royal Enfield and may render this warranty void.
12. There is no other express or implied warranty in the motorcycle. Any implied warranty of merchantability or fitness is limited to the duration of this warranty.
13. To the fullest extent allowed by law, Royal Enfield and its authorised distributors and/or dealers shall not be liable for loss of use, inconvenience, loss of time, commercial losses or other incidental or consequential damages.



---

## **EMISSION CONTROL SYSTEM WARRANTY**

---

### **YOUR WARRANTY RIGHTS AND OBLIGATIONS**

---

The California Air Resources Board and Royal Enfield Motor Company are pleased to explain the emission control system warranty on your new motorcycle. In California, new motor vehicles must be designed, built and equipped to meet the State's stringent anti-smog standards. Royal Enfield Motor Company must warrant the emission control system on your motorcycle for the periods of time listed below provided there has been no abuse, unapproved modification, neglect or improper maintenance of your motorcycle.

Your emission control system may include parts such as the carburetor or fuel-injection system, the ignition system, catalytic converter, and engine computer. Also included may be hoses, connectors and other emission-related assemblies.

Where a warrantable condition exists, within the warranty period noted below, your authorized Royal Enfield dealer will repair your motorcycle at no cost to you including diagnosis, parts and labor.

---

## **EMISSION CONTROL SYSTEM WARRANTY**

---

### **MANUFACTURER'S WARRANTY COVERAGE**

---

For a period of use of five years or 30,000 km (18641 mi), whichever first occurs, beginning on the date the motorcycle is delivered to the ultimate purchaser or, if the motorcycle is placed in service as a demonstrator or company motorcycle prior to sale at retail, the date it is first placed in service.

If any emission related part on your motorcycle is defective, the part will be repaired or replaced by Royal Enfield Motor Company. This is your emission control system defects warranty.

---

### **OWNER'S WARRANTY RESPONSIBILITIES**

---

As the motorcycle owner, you are responsible for the performance of the required maintenance listed in your Owner's Manual. Royal Enfield recommends that you retain all receipts covering maintenance on your motorcycle, but Royal Enfield cannot deny emissions warranty coverage solely for the lack of receipts or for your failure to ensure the performance of all scheduled maintenance.

---

## **EMISSION CONTROL SYSTEM WARRANTY**

---

You are responsible for presenting your motorcycle to an authorized Royal Enfield dealer as soon as a problem exists.

The warranty repairs should be completed in a reasonable amount of time, not to exceed 30 days.

As the motorcycle owner, you should also be aware that Royal Enfield may deny you warranty coverage if your motorcycle or a part has failed due to abuse, neglect, improper maintenance or unapproved modifications.

If you have any questions regarding your warranty rights and responsibilities, you should contact Royal Enfield Customer Service Department at 1-800-258-2464 (U.S. only) or 1-414-343-4056, or the California Air Resources Board at 9528 Telstar Ave., El Monte, California 91731.

---

## **ADDITIONAL WARRANTY TERMS**

---

The warranty period starts the date the motorcycle is delivered to the ultimate purchaser or, if the motorcycle is placed in service as a demonstrator or company motorcycle prior to sale at retail, the date it is first placed in service. The emission control system of each new Royal Enfield motorcycle was designed, built and tested using only Genuine Royal Enfield parts and with these parts the motorcycle is certified as being in conformity with California emission control regulations.

---

## **EMISSION CONTROL SYSTEM WARRANTY**

---

We recommend that you take your motorcycle to an authorized Royal Enfield dealer for repairs under this warranty. The dealer has factory-trained mechanics and genuine Royal Enfield parts. However, in the case of an "emergency" (as defined below), you could have repairs performed at any available service establishment or by the owner, using any replacement part. An authorized Royal Enfield dealer not being reasonably available, or a part not being available within a reasonable time period (not to exceed 30 days from the time the motorcycle is initially presented to a Royal Enfield dealer for repair) constitutes an emergency. Royal Enfield will reimburse the owner for such repairs, including diagnosis, only if it is established that the repairs are covered under this emission warranty. Royal Enfield's parts reimbursement, however, will not exceed our suggested retail price for all warranted parts replaced and our labor reimbursement will be limited to our recommended time allowances for emission system repairs at the geographically appropriate hourly labor rate.

To obtain reimbursement from Royal Enfield for such emergency repairs, you must keep all failed parts and original receipts, so you can present them to an authorized Royal Enfield dealer for inspection. Royal Enfield recommends that you bring your motorcycle to an authorized dealer for inspection to ensure that the emergency repairs were done properly.

---

## **EMISSION CONTROL SYSTEM WARRANTY**

---

Remember: Use of non-Royal Enfield replacement parts may impair the effectiveness of the emission control system or otherwise damage your motorcycle. If other than genuine Royal Enfield parts are used for maintenance, replacement or repair of components affecting emission control, you should obtain written assurances that such non-Royal Enfield parts are warranted by their manufacturer to be equal in quality to Genuine Royal Enfield parts in both performance and durability. The use of non-Royal Enfield replacement parts does not invalidate the existing warranty, if any, on other Royal Enfield components unless the non-Royal Enfield parts cause damage to warranted parts or result in the creation of an emissions non-compliant motorcycle. However, Royal Enfield assumes no liability under this warranty with respect to any parts which are not genuine Royal Enfield Parts, unless Royal Enfield Parts cause damage to non-genuine Royal Enfield Parts.

---

### **WHAT IS COVERED BY THIS EMISSION WARRANTY**

---

The emission control system warranty covers the following "warranted parts" only:

Air cleaner assembly, cam shaft, spark plug, ignition coil, ignition wires, vapor valve, catalytic converter, crankcase, breather, MAP sensor, TMAP sensor, intakeair temperature sensor, throttle position sensor, fuel injectors, induction module or throttle body, engine temperature sensor, electronic control unit, oxygen sensors, carbon canister, purge control valve, fuel tank (non-cosmetic failures only), leaks, fuel vapor separator, fuel cap. If used on the above: hoses, clamps, fittings, tubing, sealing gaskets and mounting hardware.

---

## **EMISSION CONTROL SYSTEM WARRANTY**

---

---

### **WHAT IS NOT COVERED BY THIS EMISSION WARRANTY**

---

The emission control system warranty does not cover:

Malfunctions in any "warranted parts" caused by any of the following: abuse, misuse, unapproved modification or alteration, tampering, disconnection, or improper or inadequate maintenance. The warranty also does not cover replacement of listed parts in the event that the vehicle has been rendered emissions non-compliant in the state of California through actions noted above.

Damage resulting from accident, acts of nature or other events beyond the control of Royal Enfield.

The repair or replacement of "warranted parts" which are scheduled for replacement prior to 30,000 km (18641 mi), once these parts have been replaced at the first replacement interval as part of required maintenance services.

Repairs and services performed by anyone other than an authorized Royal Enfield Dealer (except in case of emergency as defined above).

Loss of time, inconvenience, loss of use of the motorcycle, towing of the vehicle, or commercial loss and/or consequential damages.

Repairs on any motorcycle of which odometer mileage has been changed so that mileage cannot be readily determined.

---

## **NOISE CONTROL SYSTEM WARRANTY**

---

The following warranty applies to the noise control system and is in addition to the Limited Warranty, Emission Control System Warranty & California Air Resources Board Regulations. Evaporative Emission Control system Warranty. (Applicable only for motorcycles sold within the state of California.)

Royal Enfield Motors warrants the first owner and each subsequent owner, that this motorcycle is designed and built so as to conform, at the time of sale, with applicable regulations specified by the U.S. Federal Environmental Protection Agency and California Air Resources Board Regulations, that the Noise control system emission related parts fitted to this motorcycle are free from defects in materials and workmanship which may cause this motorcycle not to meet the U.S. Federal Environmental Protection Agency standards for a period of 5 years or 18,641 Miles (30,000 km), whichever occurs first, from the date of first use of the motorcycle.

The Warranty period shall begin, on the date the motorcycle is delivered to the first retail purchaser or from the first date the motorcycle is used as a demonstrator or as a display and/or trial motorcycle.

---

## **NOISE CONTROL SYSTEM WARRANTY**

---

### **THE FOLLOWING ITEMS ARE NOT COVERED BY THE NOISE CONTROL SYSTEM WARRANTY:**

---

1. Failures which may arise as a result of misuse, alterations, accidents or non performance of routine maintenance, as specified in the Owner's Manual.
2. Replacing or removing or modifying any portion of the Noise Control System (consisting of exhaust, air intake/cleaner assembly) with parts not certified to be genuine and noise legal in the USA for street use.
3. Loss of time, inconvenience, loss of motorcycle use or any other consequential loss or damages.
4. Any motorcycle in which the odometer has been tampered with, or the speedo cable has been disconnected for any reason or is broken and not replaced immediately, due to which the exact distance covered cannot be determined.



---

## **NOISE CONTROL SYSTEM WARRANTY**

---

### **RECOMMENDATIONS FOR REQUIRED MAINTENANCE**

---

It is recommended that the routine maintenance of the motorcycle be carried out at specified intervals and any maintenance to the noise control systems should be performed only by an authorised Royal Enfield service dealer and using only genuine Royal Enfield spare parts.

Repairs to the noise control system may be performed by any other qualified service outlet or individual and use of parts other than genuine Royal Enfield supplied parts is permissible, only if such agency or individuals and the non genuine parts used, are certified to comply with the U.S. Environmental protection agency standards.

---

## **EVAPORATIVE EMISSION CONTROL SYSTEM WARRANTY**

---

The following warranty applies to the evaporative emission control system.

Royal Enfield Motors warrants the first owner and each subsequent owner, that this motorcycle is designed and built so as to conform, at the time of sale, with applicable regulations specified by the evaporative emission control system related parts fitted to this motorcycle are free from defects in materials and workmanship which may cause this motorcycle not to meet applicable regulations period of 24 months from the date of first use of the motorcycle. The Warranty period shall begin either on the date the motorcycle is delivered to the first retail purchaser OR from the first date the motorcycle is used as a demonstrator or as a display and/or trial motorcycle.

---

### **THE FOLLOWING ARE NOT COVERED BY THE EVAPORATIVE EMISSION CONTROL SYSTEM WARRANTY**

---

1. Failures which may arise as a result of misuse, alterations, accidents or non performance of routine maintenance, as specified in the Owner's Manual.
2. Replacing, removing or modifying any portion of the Evaporative Emission Control System (consisting of fuel tank, fuel tank cap, canister, purge valve, throttle body, vapor hoses, fuel hoses and hose connectors) with parts not certified by Royal Enfield.

---

## **EVAPORATIVE EMISSION CONTROL SYSTEM WARRANTY**

---

3. Loss of time, inconvenience, loss of motorcycle use or any other consequential loss or damages.
4. Any motorcycle in which the odometer has been tampered with or the speedo cable has been disconnected for any reason or is broken and not replaced immediately, due to which the exact distance covered cannot be determined.
5. Normal aging of parts such as fuel hoses, vapor hoses, gaskets and rubber components.

---

## **RECOMMENDATIONS FOR REQUIRED MAINTENANCE**

---

It is recommended that the routine maintenance of the motorcycle be carried out at specified intervals and any maintenance to the evaporative emission control systems should be performed only by an Authorised Royal Enfield Service Centre and using only genuine Royal Enfield spare parts.

Repairs to the evaporative emission control system may be performed by any other qualified service outlet or individual and use of parts other than genuine Royal Enfield supplied parts is permissible. Only if such agency or individuals and the non genuine parts used, are certified to comply with the California air resources board.

---

## **WIRING DIAGRAM**

---

### **Disclaimer:**

---

It is recommended that the wiring circuit repair and any other electrical rework should be performed only by an authorized Royal Enfield service centre, failure to adhere this may cause damage to electrical systems and render the warranty of the products as void.

---

# RADIO TYPE APPROVAL

---

## TRIPPER / NAVIGATION DISPLAY UNIT - USA

---



FCC§ 15.19 Labelling requirements This device complies with part 15 of the FCC Rules and Innovation, Science and Economic Development Canada (ISED) license-exempt RSS standard(s). Operation is subject to the following two conditions:

(1) This device may not cause harmful interference, and

(2) this device must accept any interference received, including interference that may cause undesired operation.

FCC§ 15.21 Information to user Changes or modifications not expressly approved by the party responsible for compliance could void the user's authority to operate the equipment.

FCC §15.105 statement This equipment has been tested and found to comply with the limits for a Class B digital device. pursuant to part 15 of the FCC Rules. These limits are designed to provide reasonable protection against harmful interference in a residential

installation. This equipment generates, uses and can radiate radio frequency energy and, if not installed and used in accordance with the instructions, may cause harmful interference to radio communications. However, there is no guarantee that interference will not occur in a particular installation. If this equipment does cause harmful interference to radio or television reception, which can be determined by turning the equipment off and on, the user is encouraged to try to correct the interference by one or more of the following measures:

- Reorient or relocate the receiving antenna.
- Increase the separation between the equipment and receiver.
- Connect the equipment into an outlet on a circuit different from that to which the receiver is connected.
- Consult the dealer or an experienced radio/TV technician for help.

### RF Exposure Requirements

To comply with FCC RF exposure compliance requirements, the device must be installed to provide a separation distance of at least 20 cm from all persons.

---

## **SERVICE / MAINTENANCE RECORD**

---

S.No.	Type of Service	Schedule	Date	Job Card No.	km	Dealer Code	Brief Details of Service
1.							
2.							
3.							
4.							
5.							
6.							
7.							

---

## **NOTES**

---



**ROYAL ENFIELD**

Part No. RAM00359/A

ROYALENFIELD.COM

Edition : December 2021