

ROYAL ENFIELD OWNER'S MANUAL

#HIMALAYAN

USA/CALIFORNIA

FOREWORD

Welcome to the Royal Enfield family.

Royal Enfield motorcycles are being manufactured by us since 1955 with state of the art technology, while taking care to maintain the traditional Classic looks.

The motorcycle that you have just bought, confirms to United States Environment Protection Agency laws, Federal Motor Vehicle Safety Standards and California Air Resources Board regulations. (Applicable only for motorcycles sold within the state of California.)

This manual will help to acquaint yourself with the important aspects of operation, care and minor maintenance of your new Royal Enfield Motorcycle. We recommend that you read this manual carefully, before using the motorcycle, to get maximum performance and to maintain your Motorcycle in top riding condition.

We have also detailed, vital safety information for the rider and for the care and safety of the motorcycle. Please read and follow these carefully to get maximum riding pleasure and for safe riding.

We request you to exercise utmost caution while riding. Please ride cautiously, safely and within the law. Always wear a helmet, good riding goggles and proper riding clothes while riding the motorcycle. Please also insist and ensure that your pillion also follows these while riding with you.

Log on to the exciting world of Royal Enfield website : www.royalenfield.com to get to know more about the company, its products and exciting news from time to time.

We wish you many years of riding pleasure with your Royal Enfield motorcycle.

Royal Enfield team

Chennai, India.

NOTICE

All information in this manual is based on the latest product information available at the time of publication. Due to continuous improvements, there may be discrepancies between the information in this manual and your motorcycle. Royal Enfield reserves the right to make production changes at any time without prior notice and without incurring any obligation to make the same or similar changes to motorcycles previously built or sold.

All images shown are for reference to explain and need not to be exactly the same on the model you own. Technical specifications are subject to change without prior notice.

“© Copyright 2018 Royal Enfield (A unit of Eicher Motors Ltd.). All Rights Reserved. No part of this manual shall be copied, distributed or otherwise dealt without the express permission in writing of Royal Enfield”.

NOTICE

Disclaimer

1. Wash the motorcycle only with plain water. Do not use any cleaning agents or detergents, especially on painted surfaces, as it will cause discoloration and damage to the paint.
2. Do not polish your motorcycle as it will increase the gloss level and damage the paint.
3. Scratches or marks on painted / plastic surfaces cannot be removed OR touched up.
4. Warranty is not applicable for discoloration of the Silencer & Exhaust pipe, as it is a natural process that will happen during usage.

Part No. 1017116/A / Qty. 250 / Apr. '18

IMPORTANT

United States Environment Protection laws, Federal Motor Vehicle Safety Standards and California Air Resources Board (Applicable only for motorcycles sold within the state of California.) strictly prohibits tampering with the Exhaust Emission Control, Noise Control and Evaporative Emission Control systems:

We would like to emphasize that any repairs to the induction, emission, exhaust and evaporative systems must be performed only by a Royal Enfield Authorised Dealer so that the motorcycle confirms to the United States Environment Protection laws, Federal Motor Vehicle Safety Standards and California Air Resources Board regulation (Applicable only for motorcycles sold within the state of California.)

It is the responsibility of the Owner / User of the motorcycle to read this manual carefully and to comply with the safety guidelines, operating instructions, and periodical maintenance instructions given here. Keep this manual in a convenient place for easy reference. DO NOT use the motorcycle until you have become familiar with this motorcycle and after reading and understanding this manual completely. In case you need any further clarifications, please contact a Royal Enfield Authorised Dealer, nearest to you, for assistance.

IMPORTANT

If your motorcycle is being used by a friend, relative, or any other person, it is your responsibility to make certain that they have completely understood the operating procedures of the motorcycle, and the contents in this manual with particular reference to the safety aspects, before riding your motorcycle.

This motorcycle is designed for NORMAL ON ROAD USE ONLY. Operation in off-road usage in some areas may be illegal and could be dangerous. Please obey local laws and regulations.

In the event of your motorcycle being sold to another person, it is your responsibility to hand over this manual along with the motorcycle to the new owner.

REPORTING SAFETY DEFECTS

If you believe your motorcycle has a defect which could cause a crash and result in serious injury or loss of life, you should immediately contact the National Highway Traffic Safety Administration (NHTSA) in addition to notifying Royal Enfield North America Limited, 226 N Water St., Milwaukee WI 53202 US.

If NHTSA receives similar complaints, it may open an investigation and if it finds that a safety defect exists in a group of vehicles, it may order a recall and remedy campaign. However, NHTSA cannot become involved in any individual problems between you, and your dealer or Royal Enfield North America Limited.

To contact NHTSA you may call the Auto Safety Hotline toll-free within the United States on 1-800-424-9393 or write to: NHTSA, 400 Seventh Street SW, Washington, DC 20590. You can also obtain other information about motor vehicle safety from the hotline.

SAFETY DEFINITIONS

Statements in this manual preceded by the following words are of special significance:



WARNING

Indicates a potentially hazardous situation, which if not avoided, could result in an accident causing serious injury or loss of life.

CAUTION

Caution with the safety alert symbol, indicates a potentially hazardous situation, which if not avoided, may result in minor or moderate injury leading to disability.

Caution :

Caution without the safety alert symbol indicates a potentially hazardous situation, which if not avoided, may result in damage to the motorcycle and its rider, property etc.

All images in this manual are only for reference and to explain the relevance. They may not be exactly the same in the motorcycle you own. Technical specifications are subject to change without prior notice.

CONTENTS

Personal and Motorcycle Information	10
Safe Operating Rules	11
Accessories and Cargo	27
Technical Specifications	30
Recommended Lubricants	38
Motorcycle Identification Numbers	39
Location of Key Parts	42
Operation of Controls	45
Pre-Operational Checks	67
Safe & Happy Riding	69
Cargo & Accessories	74
Rules of the Road	76
Running in Period	79
Evaporative Emission Important Note	81
Warning Indications & Safety Systems	83
Starting	86
Gear Shifting, Riding & Stopping	89

CONTENTS

Parking	91
Periodical Maintenance Chart	92
Tools kit	97
Minor Maintenance Tips	98
Long Trip Precautions	122
Washing Procedure	124
Storage Precautions	129
Wiring Diagram	130
Trouble Shooting	133
Warranty Terms & Conditions	137
Emission Control System Warranty	141
Noise Control System Warranty	147
Evaporative Emission Control System Warranty	145
Service Maintenance Record	147
Notes	151

PERSONAL & MOTORCYCLE INFORMATION

Name			
Door No./ Street			
Locality			
City		Country	
Contact	Res :	Off :	
	Mobile :	Email :	
Licence No.		Valid till :	
Model		Color :	
Engine No.			
VIN. No.			
Tyre make	Front :	Rear :	
Tyre Nos.	Front :	Rear :	
Battery make		Battery No.	
Sold by			
Date of Sale			

SAFE OPERATING RULES

Royal Enfield motorcycles are designed to serve as a means of personal transport, and for on-road use only. It is not meant to be used as an off-road motorcycle.

WARNING

Using the motorcycle for Off-road purposes could lead to loss of control which could result in an accident causing serious injury or loss of life.

- Before operating your new motorcycle, it is your responsibility to carefully read and follow the operating and maintenance instructions detailed in this manual for your own safety, your motorcycle and that of others.
- Know and respect the rules of the road. Be a safe rider for your own safety and for other road users.
- Before starting the motorcycle, check for proper operation of brakes, clutch, gear shifter, handle bar controls, tyre pressures, fuel and oil levels.

FUEL / REFUELING

Royal Enfield motorcycles are designed to perform best with unleaded gasoline only. Use a good quality unleaded gasoline of 87 RON or higher. If 'knocking' or 'pinging' occurs at a steady engine speed under normal load, use a different brand of gasoline or gasoline which has a higher octane rating.

SAFE OPERATING RULES

WARNING

Royal Enfield cautions you against the use of certain nonstandard parts such as aftermarket and custom made extended front forks or suspensions, which may adversely affect performance and handling. Removing or altering original parts may adversely affect performance and could result in an accident causing serious injury.

- Use only genuine Royal Enfield spare parts and approved accessories. Use of other manufacturer's performance parts may affect the performance of your motorcycle and render the motorcycle void of warranty. See your Royal Enfield Authorised Dealer for details.

WARNING

Do not use leaded gasoline in this motorcycle. It will cause serious damage to the internals of the engine, exhaust emission system and the motorcycle will not meet the emission norms. Using leaded gasoline will also render the warranty void.

It is illegal to use leaded gasoline as it is known to cause serious health problems.

Fuels containing methanol should not be used as it can cause damage to the fuel system components.

SAFE OPERATING RULES

- Whenever refuelling your motorcycle, please exercise utmost caution and carefully observe the following rules :
 - ★ Turn the ignition switch to the 'OFF' position.
 - ★ Open the fuel filler cap slowly. This will help to release any pressure that may have built up in the fuel tank.
 - ★ **DO NOT** smoke and please ensure that there are no open flames or sparks near the motorcycle, when refuelling OR servicing the fuel system.
 - ★ **Switch OFF** mobile phones and other hand held electronic devices.
 - ★ Open the fuel filler cap slowly.
 - ★ Refuel in a well ventilated area with the engine turned off.
 - ★ **DO NOT** use a mobile telephone. Switch OFF mobile telephones and any other electrical and electronic devices including any appliances with a pilot light.
 - ★ **DO NOT** fill the tank to its brim. Please fill fuel only till the bottom of the filler neck insert, so as to leave air space in the fuel tank to allow for fuel expansion.

SAFE OPERATING RULES

- ★ Avoid filling the tank in rainy or dusty conditions where airborne material can contaminate the fuel. Contaminated fuel may cause damage to fuel system components.
- ★ After refueling, please ensure the fuel filler cap is closed firmly and correctly.



WARNING

Gasoline is extremely flammable and highly explosive. Use care when handling gasoline. Always stop the engine when refuelling or servicing the fuel system. Do not smoke or allow open flames or sparks near gasoline. Do not store motorcycle with gasoline in the tank, within the home or garage where open flames, pilot lights, sparks or electric motors are present. Inadequate safety precautions could cause an explosion or fire which could result in damage to property, serious injury.



WARNING

Fuel spilled on the floor or on motorcycle tires will reduce the tire's ability to grip the road. This can result in dangerous riding condition, potentially causing loss of control and could result in an accident. If fuel is spilled, thoroughly clean up the spillage immediately. Take care not to spill any fuel on the engine, exhaust pipes, rubber parts or any other part of the motorcycle.

SAFE OPERATING RULES

Do not store motorcycle with gasoline in the tank, within your home or garage where open flames, pilot lights, spark or any appliance with a pilot light, electric motors are present. Inadequate safety precautions could cause an explosion or fire and could result in damage to property, serious injury or loss of life.

TIRES & SUSPENSION

Please inspect and ensure tires are seated evenly & properly in the rims. Maintain the recommended tire pressures as it is very important for riding stability. Pay strict attention to loose and / or broken spokes Ensure the front and rear wheels are correctly aligned. Check spokes for correct tightness in the rims and free movement of steering system.

Inspect the tires tread condition periodically and replace worn out tires with approved make only. Failure to do so can lead to improper balance, poor stability, poor handling, and abnormal tread wear.

Please replace tires which are punctured or damaged. Small punctures in the tread area may be repaired from within the tire. The motorcycle should not be driven over 40 MPH (60 Kmph) for the first 24 hours and over 55 MPH (90 Kmph) thereafter with a repaired tire.

SAFE OPERATING RULES

 **WARNING**

In emergency situations, please ride slowly with least possible load until the tire is permanently repaired or replaced. Failure to heed to this warning could result in serious injury or loss of life.

Regularly inspect front forks, rear shockabsorbers and rear suspensions for any wear, looseness / side play, oil leaks etc. Replace worn parts. Worn parts can adversely affect stability and handling.

 **WARNING**

DO NOT operate motorcycle with a loose, worn or damaged steering system, including the front and rear suspension system. Contact your Royal Enfield Authorised Dealer for repair of steering or suspension system. Damaged steering or suspension components may adversely affect handling which could result in serious injury or loss of life.

SAFE OPERATING RULES

- A new motorcycle must be operated according to the special break-in-procedure. See BREAK-IN-THE FIRST 300 MILES (500KM) section.
- Operate motorcycle only at moderate speeds and out of traffic until you have become thoroughly familiar with its operation and handling characteristics under all conditions.
- **DO NOT** exceed the legal speed limit or drive too fast for existing conditions. Always reduce speed when poor driving conditions exist. High speed increases the influence of any other condition affecting stability and increases the possibility of loss of control.

NOTE

If you are an inexperienced rider we recommend that you obtain formal training on correct motorcycle riding techniques and become thoroughly familiar with the operation of your particular motorcycle. New riders should gain experience under various conditions while driving at moderate speeds.

SAFE OPERATING RULES

WARNING

Avoid overspeeding and never travel over the speed limit. Excessive speed may cause loss of control and could result in an accident causing serious injury.

- **DO NOT** exceed 70 MPH (110 km/h) riding solo.
- **DO NOT** exceed 55 MPH (90km/h) when carrying a passenger or cargo.

Pay strict attention to road surfaces and wind conditions. Any two wheeled motorcycle may be subject to the following upsetting forces :

- ★ Wind blasts from passing trucks.
- ★ Rough uneven road surfaces.
- ★ Slippery road surfaces.

These forces may affect the handling characteristics of your motorcycle. If this happens, reduce speed and guide the motorcycle with a relaxed grip to a controlled condition. Do not brake abruptly or force the handlebar.

SAFE OPERATING RULES

- Operate your motorcycle defensively. Remember, a motorcycle does not afford the same protection as an automobile in an accident. One of the most common accident situations occurs when the driver of the other motorcycle fails to see or recognize a motorcycle and turns into the oncoming motorcyclist.
- Safe motorcycle operation requires alert mental judgment combined with a defensive driving attitude. DO NOT allow fatigue, alcohol or drugs to endanger your safety OR that of others.
- Wear an approved helmet, clothing, and foot gear suited for riding a motorcycle. Bright OR light colors are best for greater visibility in traffic, especially at night. Avoid loose, flowing garments and scarves.
- When carrying a pillion rider, **it is your responsibility** to instruct them on proper riding procedures.
- **DO NOT** allow other individuals, under any circumstances, to operate your motorcycle unless you know they are experienced, licensed riders and are thoroughly familiar with the operating conditions of your motorcycle.
- Additional electrical accessories and equipments may overload the motorcycle's electrical system and will result in system and/or component failure.

SAFE OPERATING RULES

- Maintain your motorcycle in proper operating condition in accordance with the Maintenance intervals chart in this Owner's Manual.
- Use only genuine Royal Enfield spare parts and approved accessories. Use of other manufacturer's performance parts may affect the performance of your motorcycle and render the motorcycle void of warranty. Contact your Royal Enfield Authorised Dealer for further details.



WARNING

Maintain the recommended tyre pressure. Ensure the front and rear wheels are correctly aligned and the tyres are seated evenly & properly in the rims. Check for correct tightness of the spokes in the rims. Inspect your tyres periodically and replace tyres with approved tyres only. Failure to do so can lead to improper balance, abnormal tread wear, poor handling and could result in serious injury.

SAFE OPERATING RULES

WARNING

Royal Enfield recommends replacement of any tyre punctured or damaged. In some cases small punctures in the tread area may be repaired from within the demounted tyre by your Royal Enfield Authorised Dealer. Speed should not exceed 60 Km/h (40 MPH) for the first 24 hours after repair and the repaired tyre should Never be used over 90 Km/h (55 MPH).

In emergency situations, if a temporary repair is made ride slowly with as light a load as possible until the tyre is permanently repaired or replaced.

Failure to heed this warning could result in serious injury.

- Safe motorcycle operation requires alert mental judgement combined with a defensive driving attitude. **DO NOT** allow fatigue, alcohol or drugs to endanger your safety or that of others.
- Maintain your motorcycle in proper operating condition in accordance with the Maintenance intervals chart in this Owner's Manual. Particularly important to motorcycle stability is proper tyre inflation pressure, tread condition. Pay strict attention to loose and / or broken spokes, free movement of steering system.

SAFE OPERATING RULES

 **WARNING**

DO NOT operate motorcycle with a loose, worn or damaged steering system, including the front and rear suspension system. Contact your Royal Enfield Authorised Dealer for repair of steering or suspension system. Damaged steering or suspension components may adversely affect handling which could result in serious injury.

 **WARNING**

Regularly inspect rear shock absorbers and front forks for any defective suspension can adversely affect stability and handling which could result in serious injury.

 **WARNING**

For your personal welfare, all the listed service and maintenance recommendations should be performed. Lack of regular maintenance at the suggested intervals may affect the safe operation of your motorcycle, which could result in serious injury.

SAFE OPERATING RULES

 **WARNING**

Avoid any contact with the exhaust system. Wear clothing that will completely cover the legs while riding. The exhaust system gets very hot when the engine is running and remains too hot, even after the engine is turned off. Failure to wear proper or protective clothing could result in serious injury.

 **WARNING**

Exhaust gases contains poisonous carbon monoxide and chemicals, known to cause Cancer, Birth Defects or other reproductive defects.

DO NOT INHALE exhaust gases. Never stand close to the exhaust system of the motorcycle when the engine is running. Do not stay inside a closed garage after parking the motorcycle as the residual fumes from the exhaust can contain harmful gases. Failure to heed to these warnings can result in loss of life.

 **WARNING**

Motorcycle batteries contain lead and lead components, acids and chemicals known to cause cancer, birth defects or other reproductive harm. Exercise extreme caution while handling a battery. Wash hands thoroughly whenever a battery is handled.

SAFE OPERATING RULES

This motorcycle is not designed to tow a trailer or be used with a side car. It is designed to be used as a two wheeler, for carrying a rider and a pillion.

 **WARNING**

Towing a trailer may cause loss of control of the motorcycle in the front, reduced braking efficiency, tire overloading and unstable handling, leading to an accident resulting in serious injury or loss of life.

Using the motorcycle with a side car could cause loss of control, resulting in an accident which may cause serious injury or loss of life.

 **WARNING**

Consult your Royal Enfield Authorised Dealer regarding any questions or problems that occur in the operation of your motorcycle. Failure to do so may aggravate an initial problem, cause costly repairs, jeopardize your personal safety and could result in serious injury.

SAFE OPERATING RULES

 **WARNING**

Exceeding GVWR may lead to instability of the motorcycle, leading to an accident and result in serious injury or loss of life.

 **WARNING**

Royal Enfield cautions you against the use of certain nonstandard parts such as aftermarket and custom made extended front forks or suspensions, which may adversely affect performance and handling. Removing or altering original parts may adversely affect performance and could result in an accident causing serious injury or loss of life.

 **WARNING**

Use only genuine Royal Enfield replacement fasteners tightened to the proper torque (See your Royal Enfield Work Shop Manual). We caution you against the use of certain nonstandard parts such as aftermarket and custom made fasteners which may not have specific strength, finish and type requirements to perform properly in the assembly and its environment. The use of any nonstandard parts, including fasteners, could result in serious injury.

SAFE OPERATING RULES

 **WARNING**

DO NOT exceed the Gross Motorcycle Weight Rating of your motorcycle. The Gross Motorcycle Weight Rating (GVWR) is shown on the information plate, located on the frame Down tube. (GVWR is the sum of the weight of the motorcycle, accessories, and the maximum weight of the rider, passenger and cargo that may be safely carried.) Exceeding GVWR may lead to instability of the motorcycle, which could cause an accident and result in serious injury.

 **WARNING**

DO NOT tow a disabled motorcycle. The steering and handling for the disabled motorcycle will be impaired due to the force of the towline. If a disabled motorcycle must be transported, use a truck or a trailer. Towing a motorcycle may cause loss of control of the motorcycle in the front, leading to an accident resulting in serious injury.

 **WARNING**

DO NOT pull a trailer behind a motorcycle. Towing a trailer may cause reduced braking efficiency, tyre overloading and unstable handling. Towing a trailer may cause loss of control of the motorcycle in the front, leading to an accident resulting in serious injury.

ACCESSORIES AND CARGO

Royal Enfield cannot test and make specific recommendations concerning specific or a combination of accessories sold. Therefore, the rider must be responsible for safe operation of the motorcycle when installing accessories or carrying additional weight.

The following guidelines should be used when equipping a motorcycle, carrying cargo and / or passengers.



WARNING

DO NOT load weight or install accessories improperly on the motorcycle. Doing so may affect the motorcycle's stability handling characteristics, and safe operating speed which could result in serious accident causing serious injury.

- **DO NOT** exceed 70 MPH (110 Km/h) riding solo.
- **DO NOT** exceed 55 MPH (90 Km/h) when carrying a passenger or cargo.
- Keep cargo weight concentrated close to the motorcycle and as low as possible; this minimizes the change in the motorcycle's center of gravity.
 - ★ **Distribute weight evenly** on both sides of the motorcycle.

ACCESSORIES AND CARGO

- ★ **DO NOT** load bulky items too far behind the rider or add weight to the handlebars or front forks.
- ★ **DO NOT** exceed 5 pounds (2.3 kgs) maximum load in each saddlebag.
- ★ Recheck the cargo periodically.
- Be sure cargo is secured and will not shift while riding. Accessories secured loosely may affect the riding of the motorcycle and affect the stability of the motorcycle.
- Additional electrical accessories and equipments may overload the motorcycle's electrical system and will result in system and/ or component failure.
- Large surfaces such as fairings, windshields, backrests and luggage racks can adversely affect handling of the motorcycle. Only genuine Royal Enfield accessories, designed specifically for the motorcycle model should be used with proper installation.

ACCESSORIES AND CARGO

 **WARNING**

Royal Enfield motorcycles have been carefully designed and engineered for riding in their original configuration. DO NOT alter the handling characteristics of these motorcycles. Doing so may affect its stability and could cause an accident resulting in serious injury.

 **WARNING**

Royal Enfield cautions you against use of nonstandard parts such as aftermarket and custom made extended front forks which may adversely affect the performance and handling of the motorcycle. Removing or altering original parts may adversely affect the performance of the motorcycle, causing an accident, which could result in serious injury.

 **WARNING**

DO NOT ignore model / design specifications. Doing so constitutes to motorcycle misuse which may adversely affect the handling and performance of the motorcycle causing an accident, which could result in serious injury.

TECHNICAL SPECIFICATIONS

ENGINE

Engine Type	Single Cylinder, 4 Stroke, SOHC, Air cooled, Fuel Injection
Bore	78 mm
Stroke	86 mm
Displacement	411 cc
Compression ratio	9.5:1
Max Power	24.5 bhp (18.02 KW) @ 6500 rpm
Max Torque	32 Nm @ 4250±250 rpm
Idle rpm	1250±50 rpm
Starting System	Electric Start
Air filter element	Paper element
Lubrication	Forced Lubrication, Wet sump
Engine oil capacity	2.3 L (Initial fill only), 2.0 L (Subsequent Refills)

TECHNICAL SPECIFICATIONS

Engine oil grade SAE 15W 50 API SL Grade JASO MA 2
Cooling Air cooled with Oil cooler

IGNITION SYSTEM

Ignition system Electronic ECU / Variable
Spark plug Bosch - UR5CC
Spark plug gap 0.7 to 0.8 mm

TRANSMISSION

Clutch Wet Multi Plate
Primary drive Gear
Primary ratio 2.312:1
Gear box 5 Speed, Constant Mesh

TECHNICAL SPECIFICATIONS

Gear Ratios

1st Gear	1 st	2.916:1
2nd Gear	2 nd	1.833:1
3rd Gear	3 rd	1.428:1
4th Gear	4 th	1.173:1
5th Gear	5 th	1:000:1
Secondary Drive		5/8" Chain & Sprocket
Secondary Ratio		2.533:1
Drive Chain links		110 links

TECHNICAL SPECIFICATIONS

CHASSIS

Frame	Half duplex split cradle
Suspension	
Front	Telescopic, Hydraulic Damping, Front wheel travel: 200 mm
Rear	Swing arm with Linkage type Hydraulic damping Mono shock, Rear wheel travel: 180 mm
Brakes	
Front Disc	300mm Dia disc.
Rear Disc	240mm Dia disc.
Tyre size	
Front	90 / 90 - 21
Rear	120 / 90 - 17
Tyre Pressures	
Solo	
Front	25 PSI / 1.75 Kg/cm ²
Rear	32 PSI / 2.25 Kg/cm ²

TECHNICAL SPECIFICATIONS

With Pillion

Front	27 PSI / 1.89 Kg/cm ²
Rear	34 PSI / 2.39 Kg/cm ²
Steering lock	In built
Fuel tank capacity*	15 ± 0.5 litres approx *
Low fuel warning	Fuel Gauge (Red zone) 5.5 ± 0.5 lts.
Dead stock (unusable fuel)	0.5 litre approx.

* The above values are approximate and the actual capacity may vary with each fuel tank .

TECHNICAL SPECIFICATIONS

ELECTRICALS

Flywheel magneto	221W @ 1500 rpm
Generation	Alternator, III Phase
System	12V - DC
Battery	12V - 8 AH MF
Head lamp	12V, H4-60/55W - BULB
Brake lamp / Tail lamp	12V - 21/5W BULB
Licence Plate illuminator	12V - LED
Front position lamp	12V - LED
Speedometer lamp	12V - LED
Hi beam indicator	12V - LED
Neutral lamp telltale	12V - LED

TECHNICAL SPECIFICATIONS

Turn signal telltale	12V - LED
Turn signal	12V, 10W * 4 Nos.
Horn	12V, 2.5 Amp.
Starter Motor	12V, 0.7 KW
Instrument Cluster	Digital cluster with main and compass LCD
Side Stand indicator	LCD Indication

 **WARNING**

Using bulbs / electrical gadgets other than specified rating may lead to overloading / erratic behaviour / premature failure of electrical system.

Modifications or fitments which are not approved by Royal Enfield, will seriously affect the performance of the vehicle and will render the warranty void.

TECHNICAL SPECIFICATIONS

DIMENSIONS

Length	2190 mm
Width	840 mm
Height	1360 mm
Wheel base	1465 mm
Ground clearance.	220 mm
Saddle Height	800 mm

WEIGHTS

Kerb weight (90% fuel&oil)	191 kgs.
Max. Pay load	174 Kgs.

- Values / Dimensions mentioned above are for reference only.
- In view of continuous improvements being done on our motorcycles, the specifications are subject to change without prior notice.

RECOMMENDED LUBRICANTS

ENGINE OIL	
Grade	SAE 15W 50 API SL Grade JASO MA 2 (Semi - Synthetic)
Capacity	2.3 Ltrs. (First Fill only) 2.0 Ltrs. Approx. (during oil & filter element replacement in periodical maintenance)

FRONT FORK OIL	
Grade	2W/35
Capacity	455 ml/leg

BRAKE FLUID	
Grade	DOT 4
Capacity	Fr./Rr. 50ml

DO NOT Mix DOT 4 & Other brake fluid together.

CAUTION

Using Non Recommended / In-Correct oils, can cause serious damage to the moving parts, affect performance of the motorcycle AND void the warranty.

NOTE

Recommendation subject to change without notice.

MOTORCYCLE IDENTIFICATION NUMBER - DETAILS

The VIN is a 17 digit number punched on the right side steering head tube and in the information plate rivetted to the frame down tube.

Sample VIN :

ME3 X X XX X X G X XXXXX

Manufacturer's code	ME3	X	X	XX	X	X	G	X	XXXXXX
Type of Frame									
Type of Engine									
Variant / Version									
Ignition System									
Transmission Type									
Production Year (2016: G, 2017: H, etc.)									
Assembly factory (C-Chennai, K-Kanchipuram)									
Production Serial No.									

MOTORCYCLE IDENTIFICATION NUMBERS

FRAME NUMBER

Punched on steering head tube right side.

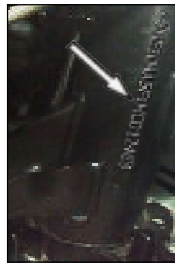

VIN INFORMATION PLATE

Riveted on the frame down tube right side.



EMISSION LABEL

Emission label on Shocks mounting tube



NOISE LABEL

Noise Label on head tube



CAUTION

It is illegal to tamper with OR alter the VIN / Engine numbers of the motorcycle as it will not only be against the law BUT will render the vehicle registration AND warranty VOID.

ENGINE NUMBER - DETAILS

The engine number is punched on the left hand side Crankcase. It is the means of identification of the Engine and its production details. Please do not tamper with the engine number as it is prohibited by law.

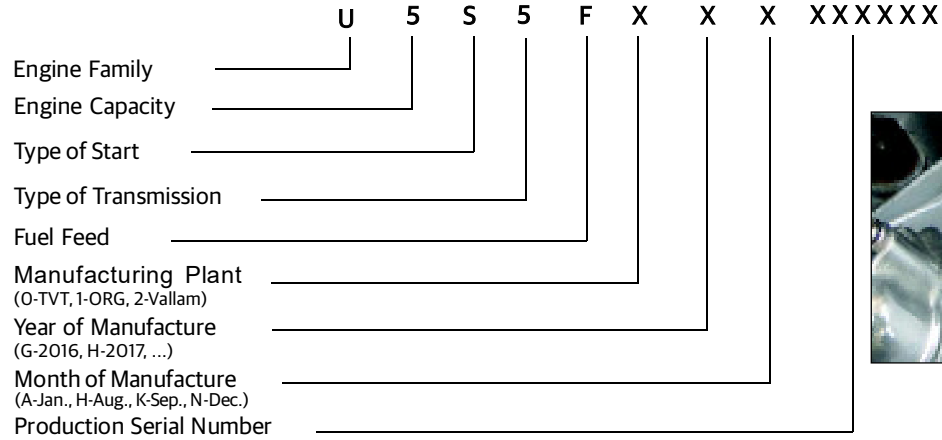

LOCATION OF KEY PARTS



1. Front Trafficator Right Side
2. Horn
3. Oil Level Window
4. Rear Brake Pedal
5. Rider Foot rest Right Side
6. Pillion Foot rest Right Side
7. Rear Trafficator Right Side

LOCATION OF KEY PARTS



1. Front Trafficator Left Side
2. Head Lamp
3. Tail Lamp
4. Rear Trafficator Left Side
5. Licence plate illuminator
6. Pillion Foot rest Left Side
7. Side Stand
8. Center Stand
9. Rider Foot rest Left Side
10. Gear Change Lever
11. Canister

LOCATION OF KEY PARTS

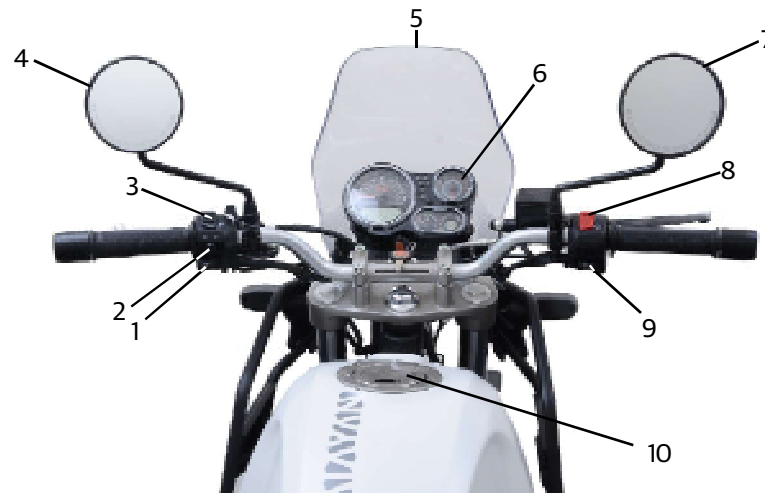

1. Horn Button
2. Turn Signal Switch
3. Head Lamp Dip Switch
4. Rear View Mirror Left Side
5. Wind Shield
6. Instrument Cluster
7. Rear View Mirror Right Side
8. Engine Stop Switch
9. Electric Start Switch
10. Fuel Tank Cap

OPERATION OF CONTROLS

STEERING LOCK

LOCKING:

- Turn handle bar to extreme left or right position.
- Switch OFF ignition, gently depress key and turn anticlockwise further till steering is locked and remove key.

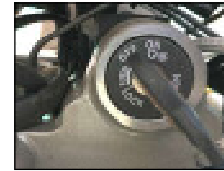

UNLOCKING:

- Insert key, turn clockwise to ignition OFF position. If required, gently shake handle bar to help unlock steering easily.

CAUTION

Do not force or attempt to lock / unlock steering if the handle bar is not in extreme left or right side. Failure to adhere to this caution will damage the lock and also cause the key to bend or break.

OPERATION OF CONTROLS

WARNING

After unlocking steering AND before starting engine, check the handle bar free movement by turning to both left and right sides, several times.

Failure to do so may cause unstable riding, leading to a potential accident, resulting in serious injury to both rider and other road users, besides causing severe damage to the motorcycle.

FUEL TANK CAP

OPENING:

- Lift flap and insert key.
- Turn key clockwise to enable cap to unlock and spring up.



NOTE

Key CANNOT be removed when fuel tank cap is open.

OPERATION OF CONTROLS

CLOSING:

- Gently depress cap till it is firmly locked in place and key can be removed.
- Remove key and close flap.



WARNING

DO NOT overfill the fuel tank, stop filling when the fuel reaches bottom of anti-splash plate. Because fuel expands when it heats up, heat from engine or the sun can cause fuel spill out of fuel tank.

Petrol is highly explosive. Please ensure there are no open flames or sparks nearby while refueling and fill fuel tank only in a well ventilated area.

Please ensure petrol does not spill on painted surfaces. Wipe immediately incase fuel spills over as otherwise it will leave a permanent stain on the painted surfaces.

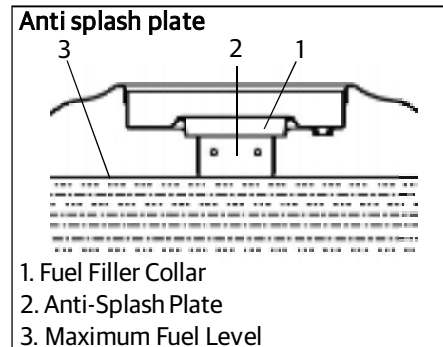

OPERATION OF CONTROLS

IGNITION SWITCH

⊗ OFF ○ ON



NOTE

- Key can be removed only if ignition is in OFF or steering is locked.

WARNING

Switch OFF ignition switch whenever engine is not running. Failure to do so will cause the battery to discharge as the headlamp will remain continuously ON when ignition switch is in ON position.

WARNING

DO NOT switch OFF ignition while riding the motorcycle. Doing so can cause a potential accident, resulting in serious injury to both rider and other road users, besides causing severe damage to the motorcycle.

OPERATION OF CONTROLS

ENGINE STOP SWITCH

 Engine OFF  Engine ON



E-START SWITCH

 Depress & hold till engine starts.





HORN

 Press



OPERATION OF CONTROLS

DIMMER SWITCH

 High beam  Low beam





DAY FLASH

Press for Head Light Flash.



TURN SIGNAL SWITCH

 Left turn signal ON
 OFF (Push to cancel)
 Right turn signal ON



OPERATION OF CONTROLS

MANUAL BI STARTER (CHOKE)

Depress and hold to stabilise idling RPM in cold condition / first time starting in cold mornings.



RIDER & PILLION SEAT

- Locate key on left side & turn clock wise Lift pillion seat and remove.
- Lift front seat from rear & remove.



DOCUMENT HOLDER

- Useful for storing motorcycle documents and owners manual.
- Remove the pillion Seat.
- Gently press on top to release the tabs from the frame and open slightly.
- To completely remove, release the bottom tabs from the frame by pulling out gently.



OPERATION OF CONTROLS

INSTRUMENT CLUSTER



A. Main LCD
B. Speedometer
C. Tell tales
D. Tachometer
E. Mode button
F. Select button
G. Compass LCD
H. Fuel gauge

OPERATION OF CONTROLS

A. MAIN LCD



The diagram shows a motorcycle LCD display with the following information: 12:00 PM, -123 °F, a gear indicator '5', ODO 81120.3 miles/km, TRIP A/B 112.7 miles/km, and a SIDE STAND indicator. Red arrows point from numbered boxes 1 through 7 to these specific elements on the display.

1	1. Clock
2	2. Ambient Temperature
3	3. Service reminder
4	4. Odometer
5	5. Trip Value (A/B & F), AVG speed A/B
6	6. Side Stand indication
7	7. Gear position indication

OPERATION OF CONTROLS

CLOCK

- Display in 12 hour format with AM/PM indication.
- Will reset to 12:00 AM when battery is disconnected.



OPERATION OF CONTROLS

CLOCK SETTING

Function	Switch	Pressure time (sec)	Action
CLOCK SETTING MODE	SELECT & MODE pressed with No Speed input	≥ 3 sec	In ignition key ON position Enters into clock setting mode and hour digits starts to blink
	SELECT	< 1 sec	Hours value shall increment by 1 accordingly for no of press
	SELECT	≥ 3 sec	Hour value saved and minute digits starts to blink
	SELECT	< 1 sec	Minutes value will increase by 1 by each press of the "Select' button
	SELECT	≥ 3 sec	Minute value save and PM/ AM digits starts to blink
	SELECT	< 1 sec	PM / AM is interchangeable by each press of the "Select' button
	SELECT	≥ 3 sec	PM / AM save and exit fromclock set mode
	NO ACTION	20 sec	Auto exit without saving changes and continue with previous setting



WARNING

NEVER attempt to operate the select or reset buttons while riding the motorcycle. Failure to do so may cause loss of concentration and unstable riding, leading to a potential accident, resulting in serious injury to both rider and other road users, besides causing severe damage to the motorcycle.

OPERATION OF CONTROLS

AMBIENT TEMPERATURE INDICATION

- Ambient temperature display can be changed from Celsius to Fahrenheit and vice versa.
- The temperature indication may increase during vehicle riding / engine ON condition due to increase of engine temperature.
- Ambient temperature indication tolerance is $\pm 2^{\circ}\text{C}$

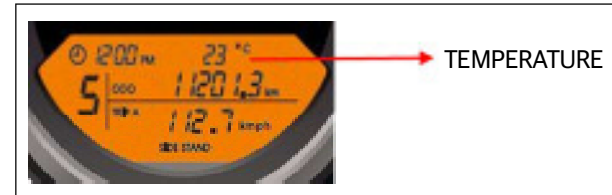

NOTE

The ambient temperature value should be referred to only when the engine is switched "OFF" and the engine is in cold condition. The temperature displayed will be higher if the engine is running or immediately after it is switched "OFF" since the sensor will only pick up the higher temperature surrounding it.

OPERATION OF CONTROLS

TEMPERATURE UNIT CHANGEOVER

Temperature sensor push button management.

Required button

- Mode



Function	Button	Pressure time (sec)	Action
TEMPERATURE UNIT CHANGE OVER	MODE	≥10 secs	In ignition key ON position, long press and hold MODE button for period ≥10 secs to reset temperature units from degree Celsius to Fahrenheit and vice versa.

 **WARNING**

DO NOT use high pressure water jet directly on instrument cluster for cleaning. Use only water spray cleaning and wipe it with soft dry cloth.

OPERATION OF CONTROLS

4. ODOMETER

- Displays the cumulative kilometers the vehicle has covered.



TRIP A/B & AVG SPEED A/B

- Trip A/B indicates distance travelled in particular trip.
- Avg A/B indicates average speed of vehicle in particular trip mode.



OPERATION OF CONTROLS

Function	Switch	Pressure time (sec)	Action
TRIP A	SELECT	<1sec	In ignition key ON position, Move to: AVA A
	SELECT	> 2.5 sec	TRIP A/AVG A RESET
AVG A	SELECT	<1sec	Move to: TRIP B
	SELECT	> 2.5 sec	TRIP A/AVG A RESET
TRIP B	SELECT	<1sec	Move to: AVG B
	SELECT	> 2.5 sec	TRIP B/AVG B RESET
AVG B	SELECT	<1sec	Move to: TRIP A
	SELECT	> 2.5 sec	TRIP B/AVG B RESET

OPERATION OF CONTROLS

TRIP "F" MODE

- The word, Trip "F" will flash when the Trip "F" mode is active.
- Trip "F" is provided to measure distance travelled by the vehicle when fuel level in the vehicle is 5.5 ± 0.5 lts. in the fuel tank so that the rider can plan fuel filling accordingly based on his trip requirements, Trip "F" will get activated when needle on fuel gauge enters the red zone.
- Trip 'F' mode would come into function automatically.
- Trip 'F' mode would de-activate automatically if fuel is filled above 5.5 ± 0.5 lts.
- During Trip 'F' mode rider can toggle between Trip A/B but mode will return automatically to Trip "F" after 25 ± 5 secs.



NOTE

- Trip "F" will stop displaying at approximately 90 ± 5 seconds AFTER fuel level in tank is above 5 ± 0.5 litres, side stand is fully retracted AND Ignition is switched ON.

OPERATION OF CONTROLS

WARNING

NEVER attempt to operate the select or reset buttons while riding the motorcycle. Doing so may cause loss of concentration and unstable riding, leading to a potential accident, resulting in serious injury to both rider and other road users, besides causing severe damage to the motorcycle.

6. SIDE STAND INDICATOR

- Indicates when side stand is extended.



OPERATION OF CONTROLS

GEAR POSITION INDICATION

- Displays the gear position in which the vehicle is traveling.
- When in neutral the indication will be "O".
- When in gear the appropriate number between 1 to 5 will be displayed.



C. TELL TALES

1. **Turn Left** : Left turn signal ON.
2. **Turn right**: Right turn signal ON.
3. **Neutral** : Transmission is in Neutral.
4. **Low Battery Indication**: Indicator will glow continuously if ignition switch is ON & engine is

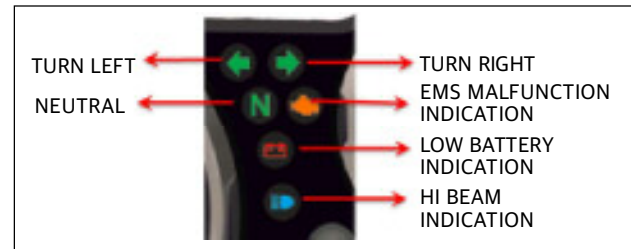

OPERATION OF CONTROLS

not running. Indication will switch off as soon as engine is started. If battery voltage is below 12 V, indicator will glow continuously indicating a low battery.

5. **High Beam Indication:** Head lamp high beam 'ON'.
6. **EMS Malfunction Indication :**
 - Will be illuminated as soon as ignition & stop switch are 'ON' and will go 'OFF' after the engine is started.
 - Will remain continuously 'ON' incase of any malfunction of the EMS.

CAUTION

DO NOT run motorcycle incase the malfunction remains 'ON' continuously as it can cause severe damage to the ECU & Sensors. Please visit the nearest authorised Royal Enfield dealer to diagnose & rectify the defect in the EMS.

OPERATION OF CONTROLS

D. TACHO METER

1. Indicates the RPM at which engine is working.
2. Useful for right selection of gear with respect to engine RPM.



WARNING

- Do not run engine with gears in neutral as RPM will go beyond red zone.
- Do not ride motorcycle in lower gears with high acceleration as it will cause RPM to start to red zone & affect the main parts inside engine.

OPERATION OF CONTROLS

G. COMPASS LCD

- Useful for Navigation during riding.
- Text indicates heading direction of vehicle. (N, S, E, W, NE, NW, SE, SW)
- Arrow will always point to North.
- Eg. if heading Northwest, text will display NW and arrow **will be in top right corner to indicate North.**



CAUTION

1. Avoid using magnetic key chains, magnetic/ferrous materials or electronic components with interference around cockpit area to avoid malfunctioning of digital compass.
2. If compass LCD enters into calibration mode ("CA" flashing) ride vehicle in "8" direction slowly to calibrate the compass or approach nearest authorised service center for assistance and proper calibration.
3. Indication fluctuation during riding is normal operation due to impact of road irregularities.
4. Compass indication tolerance is $\pm 45^\circ$.

OPERATION OF CONTROLS

WARNING

DO NOT focus on the compass while riding. Doing so may cause loss of concentration and unstable riding, leading to a potential accident, resulting in serious injury to both riders & other road users besides causing severe damage to the motorcycle.

H. FUEL GAUGE

- Indicates fuel level in tank.

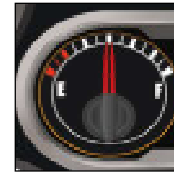

WARNING

Do not use the motorcycle for long duration with the fuel indication in red zone. Refuel at the earliest.

Failure to do so may cause the motorcycle to run out of fuel and get stranded, in addition to causing serious damage to the fuel pump.

PRE OPERATIONAL CHECKS

1. Adequate fuel in fuel tank for the journey planned.
2. Tyres inflated to correct pressure.
3. No side wall cracks, cuts or abrasions in the front and rear tyres.
4. Rear chain for proper tension and sufficiently lubricated.
5. Engine Oil level.
6. Control cables, inner, not damaged, frayed or broken. Clutch and accelerator controls working smoothly.
7. Front and rear brakes efficiency.
8. Hydraulic oil level correct in both front and rear master cylinders.
9. Free movement of handle bar to left and right sides.
10. All electrical controls, horn working correctly.

PRE OPERATIONAL CHECKS

11. Head lamp, tail lamps, brake lamps and indicator lamps working correctly.
12. Front and rear wheel axle nuts tightened properly to torque.
13. Front and rear wheel spokes having proper tightness, no loose or broken spokes.
14. All fasteners are tight to required torque.
15. Engine idling correctly and smooth.
16. No abnormal noise / leak from engine.

WARNING

For your personal welfare and safety, these pre-operational checks should be performed periodically. Failure to do so may affect safe operation, damage your motorcycle and could result in an accident causing serious injury.

SAFE & HAPPY RIDING

- Please read this manual carefully to get to know the motorcycle and its maintenance schedules.
- Please exercise utmost caution while refueling. Open the lid carefully and slowly. Refuel only in a well ventilated area with the ignition switched OFF.
- Gasoline is highly explosive and inflammable. DO NOT smoke or refuel if there are any naked flames or sparks nearby. Switch OFF mobile phones and other hand held electronic devices.
- Know and respect the rules of the road. Please be a safe rider for your own safety and for other road users.
- Please ride your motorcycle defensively. Remember a motorcycle does not afford the same protection as an automobile.
- Ride only at moderate speeds and out of traffic until you have become familiar with the handling characteristics of your motorcycle under all conditions.
- DO NOT exceed the legal speed limit. Always reduce speed when poor driving conditions exist. Use extra caution when approaching and passing through intersections, since intersections are the most likely places where accidents happen.

SAFE & HAPPY RIDING

- Ride where other motorists can easily spot you. Please do not ride in another motorist's "blind spot".
- Always signal well in advance before turning or changing lanes. Make sure that other motorists can see your signaling and slow down .
- Never ride under the influence of alcohol or other drugs that might affect your riding skills reflex.
- When carrying a pillion rider, it is your responsibility to instruct them on proper riding procedures and riding gear.
- If you are an inexperienced rider we recommend that you obtain formal training on correct motorcycle riding techniques. New riders should gain experience under various conditions while driving at moderate speeds. Pay strict attention to road surfaces and wind conditions.
- DO NOT allow other individuals, under any circumstances, to operate your motorcycle unless you know they are experienced, licensed riders and are thoroughly familiar with the operating conditions of your motorcycle.

SAFE & HAPPY RIDING

RIDING GEAR

- Motorcycle riding pants and jacket fitted with certified Armour
- Motorcycle riding boots.
- Motorcycle riding gloves.
- ISI, DOT or SNELL certified helmet as applicable for rider and pillion.
- Wear a brightly colored jacket.
- Never wear loose-fitting clothes; otherwise they could catch on the control levers, footrests, or wheels and cause injury or an accident.
- Always wear protective clothing that covers your legs, ankles, and feet. The engine or exhaust system become very hot during or after operation and can cause burns.

CAUTION

Avoid any contact with the exhaust system. The exhaust system gets very hot and remains hot for a long time after parking the motorcycle. Wear clothing that will completely cover the legs while riding. Failure to do so may result in serious burn injuries.

SAFE & HAPPY RIDING

SITTING POSTURE

Correct sitting posture is a must for stable and safe riding.

- Sit with your shoulders completely relaxed
- Do not lock your elbows and retain them at a slight bend to enable maneuvering.
- Hold the handle grip close to its inner end.
- Lightly grip the fuel tank with your knees.
- Keep your toes in "straight ahead" direction.
- Before turning, look extensively in the rear view mirror, without turning your head.

BRAKING

- Apply front and rear brakes gently and simultaneously for maximum braking efficiency.
- Please use utmost caution while applying brakes, especially while riding under wet or bad road conditions.

SAFE & HAPPY RIDING

WARNING

The hydraulic disc brakes fitted on your motorcycle requires very less effort. Applying any one of the brakes suddenly may lock the wheels. Failure to adhere to this warning may cause loss of control on the motorcycle, leading to a potential accident, resulting in serious injury to both rider and other road users, besides causing severe damage to the motorcycle.

WARNING

Brake pad wear will be increased if the motorcycle is used frequently off road. Always inspect the brake pads more frequently if the motorcycle is used off-road & replace the brake pads before they become worn to or beyond the minimum service thickness. Riding the worn brake pads may reduce braking efficiency, leading to loss of motorcycle control and an accident.

DONOT place the foot on the brake pedal while riding unless braking is required. Because this will lead to premature wear of brake pad.

CARGO & ACCESSORIES

LOADING

- Please do not fit Non OE or Non genuine accessories as they may cause damage to the motorcycle and also affect the riding and handling of the motorcycle.
- Please ensure cargo is securely strapped to the rear and sides of the motorcycle and do not become loose or shift while riding.
- Ensure the weight is distributed evenly on both sides of the motorcycle.
- Do not carry excessively heavy or huge cargo on the motorcycle.
- The permissible weight of the cargo that can be strapped to the luggage carrier is 3.5 Kgs.
- Do not hang any items on the handle bar and luggage carrier while riding which will lead to damage for the parts nearby.



WARNING

Please exercise utmost caution while carrying cargo or luggage on the motorcycle. Failure to adhere to the above precautions can cause loss of control on the motorcycle, leading to a potential accident, resulting in serious injury to both rider and other road users, besides causing severe damage to the motorcycle.

Total weight of the rider and any passenger, accessories and luggage must not exceed the maximum load limit.

CARGO & ACCESSORIES

CAUTION

Exhaust gases contains poisonous carbon monoxide and chemicals, known to cause Cancer, Birth defects or other reproductive defects. Please park the motorcycle only in a well ventilated area and do not stay in the same place where the motorcycle is parked, especially when the engine and exhaust system are hot.



WARNING

DO NOT tow a disabled motorcycle. The steering and handling of the motorcycle will be impaired due to the force of the towline. Towing a motorcycle can cause loss of control on the motorcycle, leading to a potential accident, resulting in serious injury to both rider and other road users, besides causing severe damage to the motorcycle.



WARNING

DO NOT attach a trailer to the motorcycle Attaching a trailer can cause loss of control on the motorcycle, leading to a potential accident, resulting in serious injury to both rider and other road users, besides causing severe damage to the motorcycle.



WARNING

Max load on grab rail not to exceed 5 Kg.

RULES OF THE ROAD

- Be sure your number plate is installed in the position specified by law and is clearly visible at all times.
- Ride at a safe speed that is consistent with the type of road surface you are on. Pay strict attention to whether the surface is :
 - * Dry
 - * Oily
 - * Icy
 - * Wet
- Watch for loose debris, such as leaves, slippery substances or loose gravel that can hamper the stability of your vehicle.
- DO NOT exceed the legal speed limit or drive too fast for existing conditions. Always reduce speed when poor driving conditions exist. High speed increases the influence of any other condition affecting stability and increases the possibility of loss of control.
- Keep to the correct side of the road center line when meeting oncoming vehicle.

RULES OF THE ROAD

- Always sound your horn, actuate your turn signals, and exercise caution when passing other vehicles going in the same direction. Never try to pass another vehicle going in the same direction at street intersections, on curves, or when going up/or down a hill.
- At street intersection give the right-of-way to the vehicle on your left or right. DO NOT presume you have the right-of-way.
- Always signal when preparing to stop, turn or pass.
- While turning either right or left, watch for pedestrians, animals, as well as vehicles.
- All traffic signs, including manual controls at intersections, should be obeyed promptly. SLOW DOWN at traffic signs near schools and CAUTION signs at railroad crossings.
- When intending to turn, signal at least 100 feet (30.5 meters) before reaching the turning. Be close to the center line (unless local rules require otherwise), slow down and then turn carefully.
- Never jump a traffic light. When a change is imminent from GO to STOP (or vice versa) at intersections, slow down and wait for the light to change to green. Never run through a yellow or red traffic light.
- DO NOT leave the curb or parking area without signaling. Be sure your way is clear to enter moving traffic. A moving line of traffic always has the right-of-way.



RULES OF THE ROAD

- Park your motorcycle on a firm and flat surface to prevent it from falling over.
- Protect your motorcycle against theft. After parking your motorcycle, remove Ignition key from switch and lock the steering head.

SIDE VIEW MIRRORS

Your motorcycle is equipped with convex mirrors and have a curved surface. This type of mirror is designed to give a much wider view to the rear than a flat mirror; however, cars and other objects seen in this type of mirror will look smaller and farther away than when seen in a flat mirror.

Use care when judging the size or distance of objects seen in these mirrors.



NOTE

To help you establish the relative distance of vehicles behind your motorcycle, adjust each mirror in such a way, that a small portion of your shoulder is visible and a large portion behind your motorcycle is seen clearly.

CAUTION

DO NOT high pressure water jet on mirror use only water spray cleaning and wipe with clean dry cloth.

RUNNING IN PERIOD

The Himalayan Motorcycle is capable of consistent high speeds. However as with any new motorcycle, a "RUNNING-IN" procedure is essential to help in proper "Bedding-In" of the various moving parts in your motorcycle and to achieve optimum performance subsequently.

1. During the first 2000 Kms / 1243 miles of run, do not exceed the speed limits as shown in the table below.
2. Do not exceed maximum specified pay load.
3. Warm up the engine for a few minutes at idling speed to allow engine oil to lubricate all the moving parts in the engine before riding the motorcycle.
4. Avoid full throttle operation and do not ride at constant throttle continuously. Vary the speed by 10% while riding.
5. Avoid sudden accelerations and racing starts.
6. Avoid prolonged full-throttle operation. Vary speed occasionally.

RUNNING IN PERIOD

Gear \ Motorcycle Speed	First 500 kms / 310 miles	501 - 2000 kms / 310 - 1243 miles
1	15 KMPH / 9.35 MPH	20 KMPH / 12.42 MPH
2	25 KMPH / 15.53 MPH	30 KMPH / 18.64 MPH
3	30 KMPH / 18.64 MPH	40 KMPH / 24.85 MPH
4	45 KMPH / 27.96 MPH	55 KMPH / 34.17 MPH
5	60 KMPH / 37.28 MPH	80 KMPH / 49.70 MPH

EVAPORATIVE EMISSION IMPORTANT NOTE

California Air Resources Board, Emissions Regulations (Applicable for motorcycles sold in the State of California).

Your Royal Enfield motorcycle is equipped with an evaporative emission control system consisting of a Canister, rubber hoses and connectors to comply with the stringent California Air Resources Board (CARB) emissions regulations, anti-smog standards.

The equipment does not have any serviceable parts for the user to service. However in order to ensure that the motorcycle is compliant, it is necessary to periodically inspect the rubber tubes and connections for any leaks, cracks, cuts or damage. In case any of the above is noticed, the motorcycle should be taken immediately to a nearest Royal Enfield Authorised Dealer for inspection and necessary correction.

The evaporative emission control system is covered under warranty for 18,641 miles (30,000 Kms) OR 5 Years from the date of sale of the motorcycle to the first customer.

As the vehicle owner, it is your responsibility to ensure that the motorcycle is taken to the nearest Royal Enfield Authorised Dealer to carry out the required maintenance listed in the Owner's Manual. Royal Enfield recommends that you retain all receipts covering maintenance on your motorcycle. It is also your responsibility to present take your motorcycle to a

EVAPORATIVE EMISSION IMPORTANT NOTE

Royal Enfield Authorised Dealer, if a problem in the evaporative emission system. As the vehicle owner, you should also be aware that Royal Enfield may deny your warranty coverage if your vehicle or a part has failed due to abuse, neglect, improper maintenance or unapproved modifications. If you have any questions regarding your warranty rights and responsibilities or if a Royal Enfield Authorised Dealer cannot repair your motorcycle or honor your claim within a reasonable period of time, contact Royal Enfield for assistance @ 312-569-1075. If you are not satisfied with the way in which a warranty claim is resolved by Royal Enfield, you may write directly to:

Director of Field Operations
Board Support Division (E14-397F)
Environmental Protection Agency
401M Street, S.W. Washington,
D.C. 20460

OR

California Air Resources
9480 Telstar Ave. Suite 4
El Monte, CA 91731

WARNING INDICATIONS & SAFETY SYSTEMS

YOUR MOTORCYCLE IS FITTED WITH THE FOLLOWING WARNING INDICATIONS AND SAFETY SYSTEMS:

1. LOW FUEL INDICATION

The fuel pointer enters red zone, if the fuel level in the fuel tank is approximately 5.5 ± 0.5 litres.

Please ensure the motorcycle is not used with the low fuel indicator lamp 'ON' continuously. It may not only result in the motorcycle running out of fuel. BUT will also cause serious damage to the fuel pump. Please refuel as soon as the low fuel indication comes 'ON'.

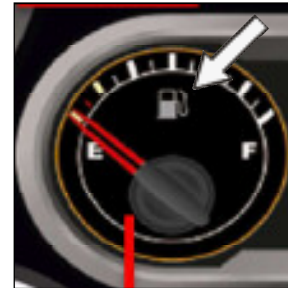

WARNING INDICATIONS & SAFETY SYSTEMS

2. ENGINE MALFUNCTION INDICATOR LAMP

A Malfunctioning Indicator Lamp (MIL) is provided in the small meter.

When both the Ignition & Engine kill switch is 'ON' and after vehicle is started, the MIL will glow for few seconds and switch 'OFF', this indicates that all the functions of Electronic fuel injection (EFI) system is functioning normally.

In the event of any malfunction in the EFI System the MIL will glow continuously. It is recommended to take the motorcycle to a nearest Royal Enfield Authorised service station for a detailed inspection and correction of the EFI system.



WARNING INDICATIONS & SAFETY SYSTEMS

3. ROLL OVER SENSOR

In the event of motorcycle falling over on either of its sides with the engine running and the gears engaged the Roll over sensor will "disable" both the ignition and fuel systems and switch 'OFF' the engine. This is to prevent any damage to the motorcycle and its rider. To reset the Roll over sensor and reactivate the ignition and fuel systems.

- Ensure the motorcycle is made upright and is on its center stand.
- Ensure gears are in correct neutral and the neutral lamp is glowing in the instrument console.
- Switch 'OFF' both ignition & stop switches, wait for a few seconds and switch 'ON' the Ignition and stop switch again, to start the engine.

STARTING

- Ensure Gear is in Neutral position and the Neutral lamp is glowing in the Instrument Cluster. To shift into neutral, move the motorcycle back and forth gently, while simultaneously shifting the gear.

CAUTION

Do not attempt to shift gears when engine is 'OFF' and rear wheel is stationary as it will cause damage to gear shift mechanism. Please move motorcycle back and forth while simultaneously shifting gears.

- Switch 'ON' Ignition and the Stop Switch to 'RUN' Position.



STARTING

- Depress Clutch Lever fully.

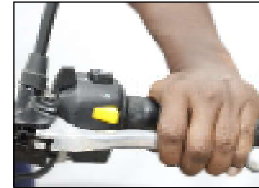

- Press starter button and hold till engine starts.

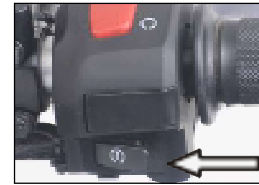

CAUTION

In case engine does not start, do not keep starter button pressed continuously as it will drain the battery. Release button and restart after a few minutes to allow battery to recoup.

STARTING

CAUTION

Never accelerate the engine immediately after a cold start. The engine should be allowed to run slowly for 15 to 30 seconds. This will allow the engine to warm up and let oil reach all surfaces needing lubrication. Failure to adhere in damage to the engine.

- Manual Bi Starter

NOTE

It is mandatory, necessary to depress and hold the Manual Bi-starter for a minimum of one minute when starting the engine for the first time in cold morning, every time when the temperatures are below 10 deg C, and at higher altitudes to keep the engine idling RPM steady.

As soon as the engine sufficiently warms up then Manual Bi-starter should be released.



GEAR SHIFTING, RIDING & STOPPING

- Warm up engine for 2 minutes - until idling is consistent.

GEAR SHIFT PATTERN

1—N—2—3—4—5

- Press clutch lever towards the hand grip.
- Press gear pedal with toe to engage 1st gear.
- Gently open throttle and release clutch simultaneously. If clutch is released suddenly, the engine may stall and cause a jerky start.



CAUTION

The clutch must be fully disengaged before attempting a gear shift. Failure to fully disengage the clutch may cause a jerky start OR stalling the engine besides causing damage to transmission parts.

GEAR SHIFTING, RIDING & STOPPING

- Lift gear lever with toe to engage 2nd and subsequent gears.

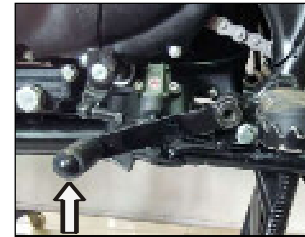

NOTE

Always start the engine with gear in neutral position.

Always move the motorcycle in first gear position only.

The motorcycle may begin to slow down and show lack of power while climbing steep hills. In that case, you should shift to a lower gear so that engine will be operating in normal power range which will prevent the motorcycle from losing momentum. The engine may be used for braking by shifting to a lower gear while riding down to steep hill.

PARKING

PARKING MOTORCYCLE ON SIDE STAND

- Select a firm, flat surface.
 - Extend side stand. Tilt the motorcycle to the left, till it is supported firmly.
-

CAUTION

When Side stand is in extended position.

- a) Engine will start if vehicle is in neutral, but will cut-off (ignition and fuel) when gear is engaged.
 - b) Engine will not start if gear is engaged already.
-

⚠ WARNING

- Ensure side stand is retracted fully before riding the motorcycle.
- Please exercise extreme care while parking and ensure it is parked firmly to avoid the motorcycle from falling over and causing injury to you or to others and damage to the motorcycle parts.
- Do not ride motorcycle with the side stand extended. Doing so can cause the side stand to touch the ground while cornering and result in instability & loss of control on the motorcycle leading to a potential accident result in serious injury to both sides and other road users besides causing severe damage to the motorcycle.

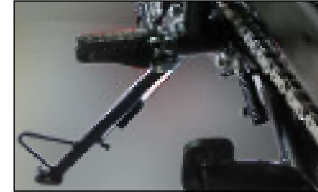

PERIODICAL MAINTENANCE

The Periodical maintenance schedule detailed below is based upon average riding conditions and indicates the Intervals at which regular inspections, adjustments, replacements and lubrications must be carried out to help maintain your Himalayan motorcycle meticulously. If in case the motorcycle is used frequently in very dusty environment / severe climatic conditions / Poor Roads / stagnant water etc., the maintenance will need to be done earlier as may be required.

Contact a nearest Royal Enfield Authorized Dealer / Service Center to carry out the periodical maintenance and for any expert advice.

Sl. No.	DESCRIPTION	PERIODIC MAINTENANCE																					
		Kms (x 1000)						Miles (x 1000)															
		0.5	5	10	15	20	25	30	35	40	45	50	0.3	3	6	9	12	15	18	21	25	28	31
1	Engine Oil (Level check / Replace)	R	I	R	I	R	I	R	I	R	I	R	R	I	R	I	R	I	R	I	R	I	R
2	Oil Filter Element	R		R		R		R		R		R											R
3	Engine oil strainer on crankcase LH	C		C		C		C		C		C											C

A : Adjust C : Clean I : Inspect T : Re-tighten (2) L : Lubricate R : Replace

I & R® : Inspect & If necessary Replace I/A/R® : Inspect / Adjust / If necessary Replace

* Refer Service Manual. RPM setting done every service. # Check every time after vehicle is used for off road riding.	1. Tyre to be replaced if the tyre wear identification mark reached. 2. To be done at authorised Royal Enfield Dealer / Service Center. 3. If not replaced, Inspect & If necessary Replace at every Service interval, If Replaced repeat the schedule. 4. Check for oil leakages during service.
---	---

For maintenance after 31,000 miles / 50,000 Kms., please repeat same frequency specified above, in consultation with a Royal Enfield Authorised Dealer / Service Center.

PERIODICAL MAINTENANCE

Sl. No.	DESCRIPTION	PERIODIC MAINTENANCE											
		Kms (x 1000)	5	10	15	20	25	30	35	40	45	50	
	Miles (x 1000)	0.3	3	6	9	12	15	18	21	25	28	31	
4	Inlet/ Exhaust Tappet setting	I & A	I & A	I & A	I & A	I & A	I & A	I & A	I & A	I & A	I & A	I & A	
5	Rubber hose, Inlet manifold *	I	I	I & R®		I & R®	I	I & R®	I	I & R®	I	I & R®	
6	Spark plug	C & A	C & A	C & A	R	C & A	C & A	R	C & A	C & A	R	C & A	
7	HT leads for crack	I	I & R®	I & R®	I & R®	I & R®	I & R®	I & R®	I & R®	I & R®	I & R	I & R®	
8	Fuel Hose	I	I	I	I & R®	I	I	I & R®	I	I	I & R®	I	
9	Fuel Hose & Clip/ Injector 'O' ring/ Seal Ring	I	I	I	I & R®	I	I	I & R®	I	I	I & R®	I	
10	Fuel Pump	Check for screw tightness in all services											
11	Air filter element	C	C	R	C	R	C	R	C	R	C	R	
		Clean/ Replace more frequently if motorcycle always used industry / off Road conditions.											

A : Adjust C : Clean I : Inspect T : Re-tighten (2) L : Lubricate R : Replace

I & R® : Inspect & If necessary Replace I/A/R® : Inspect / Adjust / If necessary Replace

* Refer Service Manual.
RPM setting done every service.
Check every time after vehicle is used for off road riding.

1. Tyre to be replaced if the tyre wear identification mark reached.
2. To be done at authorised Royal Enfield Dealer / Service Center.
3. If not replaced, Inspect & If necessary Replace at every Service interval, If Replaced repeat the schedule.
4. Check for oil leakages during service.

For maintenance after 31,000 miles / 50,000 Kms., please repeat same frequency specified above, in consultation with a Royal Enfield Authorised Dealer / Service Center.

PERIODICAL MAINTENANCE

Sl. No.	DESCRIPTION	PERIODIC MAINTENANCE											
		Kms (x 1000)	5	10	15	20	25	30	35	40	45	50	
	Miles (x 1000)	0.3	3	6	9	12	15	18	21	25	28	31	
12	Accelerator Cable	I	I	I/A/R®	I	I/A/R®	I	I/A/R®	I	I/A/R®	I	I/A/R®	
13	Rubber Hose, Air filter to Throttle body	I	I	I&R®	I	I&R®	I	I&R®	I	I&R®	I	I&R®	
14	PAV pipes & Hose clip	I	I	I	I	I	I&R®	I	I	I	I	I&R®	
15	Throttle body- Cleaning spray*	Carbo cleaner/ carb click/ or Fuel line cleaner spray every 6000 Km or 6 months whichever is earlier											
16	Clutch Cable	I	I	I/A/R®	I	I/A/R®	I	I/A/R®	I	I/A/R®	I	I/A/R®	
17	Clutch free play	Adjust every 1000 Kms or earlier as required											
18	Clutch no slippage	I	I	I	I	I	I	I	I	I	I	I	
19	Steering head bearings #	I & A	I & A	L & A	I & A	L & A	I&R®	I & A	L & A	I & A	L & A	I&R®	
A : Adjust		C : Clean		I : Inspect		T : Re-tighten (2)		L : Lubricate		R : Replace			
I & R® : Inspect & If necessary Replace		I/A/R® : Inspect / Adjust / If necessary Replace											
* Refer Service Manual. RPM setting done every service. # Check every time after vehicle is used for off road riding.		1. Tyre to be replaced if the tyre wear identification mark reached. 2. To be done at authorised Royal Enfield Dealer / Service Center. 3. If not replaced, Inspect & If necessary Replace at every Service interval, If Replaced repeat the schedule. 4. Check for oil leakages during service.											

For maintenance after 31,000 miles / 50,000 Kms., please repeat same frequency specified above, in consultation with a Royal Enfield Authorised Dealer / Service Center.

PERIODICAL MAINTENANCE

Sl. No.	DESCRIPTION	PERIODIC MAINTENANCE											
		Kms (x 1000)	5	10	15	20	25	30	35	40	45	50	
		Miles (x 1000)	0.3	3	6	9	12	15	18	21	25	28	31
20	Front Fork oil* (4)		I	I	I	I	I&R®	I	I	I	I&R®	I	I
21	Fuel Pipe		I	I	R	I	R	I	R	I	R	I	R
22	Battery terminals (apply petroleum jelly)		C	C	C	C	C	C	C	C	C	C	C
23	Earth wire eyelet Tightness				I		I		I		I		I
24	Hydraulic Brake Fluid - Front & Rear #		I	I	R	I	R	I	R	I	R	I	R
25	Hydraulic brake hose & Washers - Front & Rear #		I	I	I	I	I	I	I	I	I	I	I
26	Brake Pads - Front & Rear #		I	I&R®	I&R®	I&R®	I&R®	I&R®	I&R®	I&R®	I&R®	I&R®	I&R®
27	Tyre wear pattern (Front & Rear)# (1)		I	I&R®	I&R®	I&R®	I&R®	I&R®	I&R®	I&R®	I&R®	I&R®	I&R®
28	Spokes tightness / Wheel rim run out front & rear #		I	I	I	I	I	I	I	I	I	I	I

A : Adjust C : Clean I : Inspect T : Re-tighten (2) L : Lubricate R : Replace
 I & R® : Inspect & If necessary Replace I/A/R® : Inspect / Adjust / If necessary Replace

* Refer Service Manual.
 RPM setting done every service.
 # Check every time after vehicle is used for off road riding.
 1. Tyre to be replaced if the tyre wear identification mark reached.
 2. To be done at authorised Royal Enfield Dealer / Service Center.
 3. If not replaced, Inspect & If necessary Replace at every Service interval, If Replaced repeat the schedule.
 4. Check for oil leakages during service.

For maintenance after 31,000 miles / 50,000 Kms., please repeat same frequency specified above, in consultation with a Royal Enfield Authorised Dealer / Service Center.

PERIODICAL MAINTENANCE

Sl. No.	DESCRIPTION	PERIODIC MAINTENANCE											
		Kms (x 1000)	5	10	15	20	25	30	35	40	45	50	
	Miles (x 1000)	0.3	3	6	9	12	15	18	21	25	28	31	
29	Front & Rear wheel bearings for play #	I	I	I	I	I	I&R®	I	I	I	I	I&R®	
30	Swing arm Pivot bearings #	I & L	I & L	I & L	I & L	I & L	I & L	I & L	I & L	I & L	I & L	I & L	
31	Rear Suspension Linkages #	I	I & L	I & L	I&R®	I & L	I & L	I&R®	I & L	I & L	I&R®	I & L	
32	Rear Drive Chain #	Clean, Lubricate & Adjust every 1000 Kms or earlier as required											
33	Drive chain & Sprockets set #	I	I	I&R®	I	I&R®	I	I&R®	I	I&R®	I	I&R®	
34	Rear wheel cush drive rubbers #	I	I	I&R®	I	I&R®	I	I&R®	I	I&R®	I	I&R®	
35	All Mounting Fasteners in vehicle for tightness #	I & T	I & T	I & T	I & T	I & T	I & T	I & T	I & T	I & T	I & T	I & T	
36	Hand levers, Centrestand, side stand, Rider & Pillion foot rest Pivots & Gearshift Levers #	Lubricate every 1000 Kms or earlier as required											
37	Evaporative Emission Equipment rubber hoses *	I	I	I	I&R®	I	I	I&R®	I	I	I&R®	I	

A : Adjust C : Clean I : Inspect T : Re-tighten (2) L : Lubricate R : Replace
 I & R® : Inspect & If necessary Replace I/A/R® : Inspect / Adjust / If necessary Replace

* Refer Service Manual.
 RPM setting done every service.
 # Check every time after vehicle is used for off road riding.
 1. Tyre to be replaced if the tyre wear identification mark reached.
 2. To be done at authorised Royal Enfield Dealer / Service Center.
 3. If not replaced, Inspect & If necessary Replace at every Service interval, If Replaced repeat the schedule.
 4. Check for oil leakages during service.

For maintenance after 31,000 miles / 50,000 Kms., please repeat same frequency specified above, in consultation with a Royal Enfield Authorised Dealer / Service Center.

TOOLS KIT

The tool kit is strapped underneath the Pillion seat.

S.No.	Tool Description	Purpose	Qty.
1	Allen Key 4 mm	To remove side panels LH & RH	1
2	Allen Key 6 mm	To Loosen / tighten pinch bolt on fork end	1
3	Tool Spark Plug	To Loosen / tighten Spark plug	1
4	Screw Driver	To loosen / tighten screws of housing	1
5	Extension Tube	Additional leverage for loosening tightening wheel axle nuts	1
6	Combination Spanner Open end 17 * 13 mm	To loosen / tighten hex nuts	1
7	Combination Ring Spanner 24 * 14 mm	To Loosen / tighten wheel axle nuts	1
8	D.E. Spanner 10 * 12 mm	To loosen / tighten hex nuts	1
9	Tool wallet	For storing tools	1

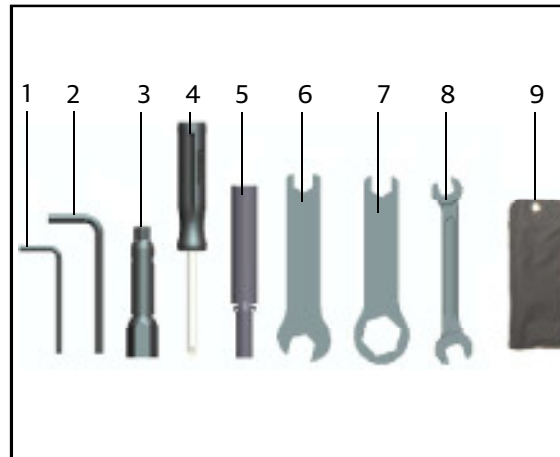

MINOR MAINTENANCE TIPS

The following simple maintenance activities will help in maintaining your motorcycle. However if you are in experienced or feel it is best done by an experienced person, we recommend you to get in touch with a Royal Enfield Authorised Dealer / Service Center.

HAND LEVER PIVOTS

Wipe the area free of dirt / grease.

Apply a few drops of oil on the pivots.



SIDE STAND PIVOTS

Apply a few drops of oil on the pivots after cleaning the area of dirt.



MINOR MAINTENANCE TIPS

DRIVE CHAIN

Clean the drive chain carefully. Apply chain lubricant while simultaneously rotating the rear wheel. Wipe off the excess lubricant.

OIL LEVEL INSPECTION

- Place motorcycle on its center stand on a firm surface.
- Warm up engine for a few minutes & switch off before checking oil level.
- The level is correct if the oil level is in the middle of the oil level window.
- Top up only with recommended Engine oil.



CAUTION

Using Non Recommended / In-Correct oils, can cause serious damage to the moving parts, affect performance of the motorcycle AND void the warranty.

MINOR MAINTENANCE TIPS

SPARK PLUG

CLEANING AND ADJUSTING PLUG GAP

- Remove spark plug using the plug spanner and tommy bar.
- Clean the insulator tip and electrodes of the plug carefully.
- Clean & adjust electrode gap every 500 km if required and replace every 15,000 kms.
- Refit the spark plug on the cylinder head.

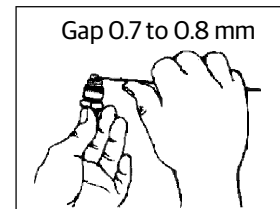

BRAKE FLUID

- Check fluid level is between "MIN & MAX".
- Top up with DOT 3 OR DOT 4, if required.
- Do not overfill.
- DO NOT mix DOT 3 & 4 brake fluids.



FRONT BRAKE



REAR BRAKE

MINOR MAINTENANCE TIPS

CAUTION

Brake fluid is highly corrosive and can cause damage to painted parts. Please ensure brake fluid does not spill on any part of the motorcycle. In the event of a spill, please clean the area immediately with a soft cloth (preferably a wet cloth) to avoid damage.

INSPECTION OF TYRES AND RIMS

- Periodically inspect :
 - Rims for spokes breakage wheel rim and run-out.
 - Tyres for proper seating of the beading on the rims.
- Check and remove stone, splinters, nails or other sharp particles embedded in the tyre.
- Replace tyres if
 - Side wall cracks, cuts or damages, uneven lugs wear etc.
 - Tyre lugs work out upto the "wear indicator" symbol on the side wall.



MINOR MAINTENANCE TIPS

- Use only recommended tyres & tubes, inflated to correct air pressure.

	Front	Rear
Solo	1.75 kg/cm ² (25 PSI)	2.25 kg/cm ² (32 PSI)
With Pillion	1.89 kg/cm ² (27 PSI)	2.39 kg/cm ² (34 PSI)

WARNING

Dismantling and reassembly of the wheel should be done **ONLY** by an experienced technician.

Failure to do so may cause loss of control on the motorcycle, leading to a potential accident, resulting in serious injury to both rider and other road users, besides causing severe damage to the motorcycle.

MINOR MAINTENANCE TIPS

FRONT WHEEL REMOVAL

- Support front end of engine suitably such that the front wheel is off the ground.
- Loosen pinch bolt on right fork end with 6 mm Allen key.
- Hold spindle on right side and remove spindle nut and washer from left side.
- Support wheel and pull out spindle from right side.
- Remove wheel along with wheel speed sensor and spacer.
- Remove speedo sensor.

CAUTION

Do not press the brake lever when wheel is removed as this will result in the brake pads coming out too far from the brake caliper.

- Place a suitable spacer of 4 mm thickness, between the brake pads to avoid accidental compression of the brake lever.

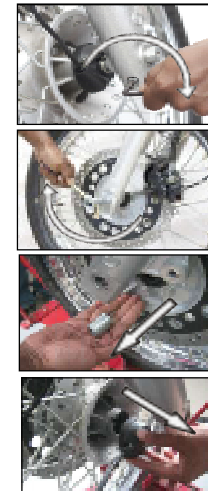

MINOR MAINTENANCE TIPS

FRONT WHEEL REASSEMBLY

- Remove the spacer placed between the brake pads.
- Locate wheel speed sensor lugs on the hub slot carefully.
- Position wheel along with wheel speed sensor and spacer on left side between the front fork legs, ensuring the brake disc is located between the brake pads.
- Insert wheel spindle from right fork end.
- Position wheel speed sensor such that it is parallel to ground.
- Hold spindle on right side, locate washer and nut on spindle on left side and tighten firmly.
- Tighten pinch bolt on right fork end.
- Rotate wheel and check for smooth rotation.
- Press brake lever and check front brake for efficiency.



MINOR MAINTENANCE TIPS

REAR WHEEL REMOVAL

- Ensure the motorcycle is on a firm, flat surface and the rear wheel is off the ground.
- Gently remove the brake hose along with its rubber grommets from the locating clips on the swing arm.
- Loosen rear axle nut on the right side and remove along with washer.
- Pull out the wheel axle from the left side, taking care not to drop the wheel spacers.
- Remove the brake caliper assembly from the slot in the swing arm and support it suitably, to avoid damage to the brake hose.
- Slide out the rear wheel from the swing arm, taking care not to drop the spacers on the wheel hub.

CAUTION

Do not press the brake pedal when wheel is removed as this will result in the brake pads coming out too far from the brake caliper.

* Place a suitable spacer of 4 mm thickness, between the brake pads to avoid pads compression in the event the brake pedal is pressed accidentally.



MINOR MAINTENANCE TIPS

REAR WHEEL REASSEMBLY

- Ensure the cush rubbers are in place in the wheel hub.
- Insert the wheel assembly between the swing arms and position the cush rubbers on the rear sprocket lugs correctly.
- Remove the spacer between the brake pads and locate the caliper such that the brake disc is between the brake pads.
- Locate the caliper bracket slot on the lug in the swing arm.
- Position the respective spacers on the left and right side of the wheel hub.
- Ensure the axle mounting hole in the swing arm, wheel hub and caliper bracket are aligned.
- Insert the wheel axle from the left side of the swing arm and gently tap it in.



MINOR MAINTENANCE TIPS

CAUTION

- Do not force the spindle through as it will cause damage to the threaded end.
- Ensure correct chain tension and rear wheel alignment with front wheel by adjusting the adjusters on both left and right side of swing arm.
- Assemble washer and wheel axle nut on right side and tighten to correct torque.
- Fix the brake hose pipe in swing arm clips properly.

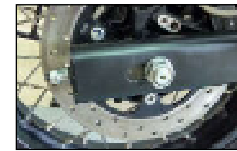

CAUTION

- Please ensure the brake hose is correctly positioned on the clips, without any twist, sharp kinks or damage as it will seriously affect the performance of the rear brake.
- Check rear brake for effectiveness and correct functioning before using the motorcycle.



MINOR MAINTENANCE TIPS

DRIVE CHAIN TENSION (FREE PLAY 25-30MM)

- Measure the drive chain free play on the top run of the chain.
- The recommended free play is 25 to 30 mm.

To adjust the chain tension and free play:

- Loosen rear wheel spindle nut.
- Loosen lock nuts of the chain adjuster on both ends of the swing arm.
- Tighten / loosen the adjuster nut on left swing arm end, to reduce / increase chain tension.
- Ensure the ground is level & firm and place the motorcycle in its centre stand.
- Rotate wheel slowly and check chain free play at the top run to be between 25 - 30 mm.

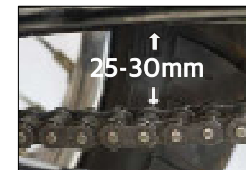

⚠ WARNING

Please follow instructions as per periodical maintenance.

MINOR MAINTENANCE TIPS

- Tighten / loosen adjuster nut on right side to align the front and rear wheels and also to align the reference marks on both left and right side of the swing arm.
- Tighten the lock nuts against the adjuster nuts, taking care not to disturb the adjuster nut settings.
- Tighten rear wheel spindle nut to a specified torque.



WARNING

Chain slackness beyond 30mm will lead to chain slippage.

Maintain drive chain slackness within the specified limits at every 1000 kms / 621 miles interval.

Please Check the front and rear wheels are correctly aligned, after the chain adjustment.

If the Engine / Rear sprocket are worn, replace the Engine / Rear sprocket & Rear chain as a kit.

MINOR MAINTENANCE TIPS

ADJUSTMENTS - CLUTCH LEVER FREE PLAY

Clutch Lever (free play 2 - 3 mm)

- Loosen the cable outer lock nut (A).
- Turn the Nut (B) Clockwise to reduce the play or Anticlockwise to increase the free play.
- Check free play 2 to 3 mm at Clutch lever pivot on handle bar end.
- Tighten lock nut (A) after adjustment is done.

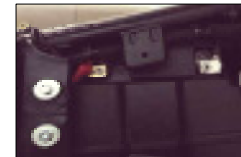
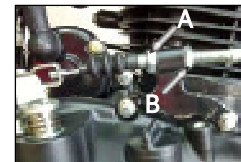
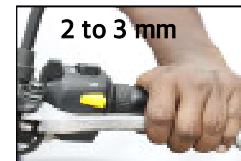

BATTERY & MAINTENANCE

- The Motorcycle is provided with 12V - 8 AH MF battery.
- The battery must be periodically checked for corrosion free terminals.

MINOR MAINTENANCE TIPS

REMOVAL OF BATTERY FROM THE MOTORCYCLE

- Remove side panel on the right side by unscrewing 2 hex socket button head screws.

- Unlock (turn the key clockwise) and remove the pillion seat.
- Remove front seat.

- Disconnect both the terminal wires (negative first and positive next respectively).

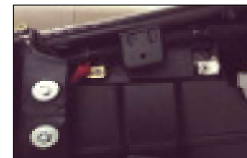

MINOR MAINTENANCE TIPS

- Remove the battery carrier bracket by loosening the hex bolt.
- Remove the battery.

WARNING

Always disconnect the Black negative (-) battery cable first and then the Red positive (+) cable while removing the battery connections.

REASSEMBLY OF BATTERY ON MOTORCYCLE

- Position the battery in the battery carrier such that the terminals are facing inside.
- Ensure ignition switch is in 'OFF' condition.
- Connect the red wire to the positive terminal of the battery first.
- Next, connect the black wire to the negative terminal of the battery.
- Smear the terminals with petroleum jelly. (Do not use grease in the battery terminals).

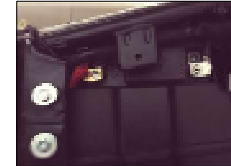

MINOR MAINTENANCE TIPS

- Place the terminal boot / cap properly.
- Refit the battery bracket.
- Refit right side panel.
- Reassemble Rider seat & Pillion seat.

NOTE

Clean the wire terminals free of corrosion and keep the terminals coated with petroleum jelly.

CAUTION

Keep the +ve and -ve cables firmly connected to the respective battery terminals. Failure to do so may result in damage to the motorcycle electrical system.

MINOR MAINTENANCE TIPS

CHANGING ELECTRICAL COMPONENTS

HEADLAMP BULB DISMANTLING

- Remove the 2 screws holding the head lamp rim to the housing.
- Gently pull out the head lamp rim along with reflector assembly.
- Disconnect head lamp coupler.

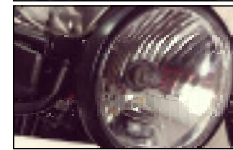

MINOR MAINTENANCE TIPS

- Remove the protective rubber cap over the bulb
- Gently press the bulb holding clip and release it from the slot in the reflector.
- Remove the bulb from the reflector.

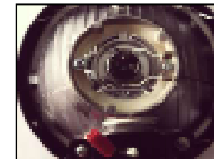

NOTE

Never touch the bulb with your fingers. Finger prints will etch the glass and decrease bulb life.
Always hold the bulb with clean dry cloth during handling.
Don't disturb the vent cap provided in the inner body mould.



MINOR MAINTENANCE TIPS

HEAD LAMP BULB REPLACEMENT

- Locate the 3 lugs in the bulb correctly in the reflector.

- Locate the bulb holding clip over the bulb and lock it in the slot in the reflector.

- Put the protective rubber cap over the bulb correctly such that the vent pipe is facing downwards.

- Connect head lamp coupler on the bulb terminals correctly.

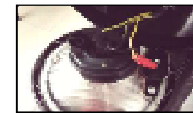
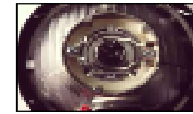

MINOR MAINTENANCE TIPS

- Locate the head lamp rim in the housing correctly such that it locks in place and the 2 mounting holes of the rim are aligned with the holes in the housing.
- Assemble the 2 screws and tighten firmly.



TAIL LAMP BULB

- Locate key on left side & turn clock wise lift pillion seat and remove.
- Remove the tail light glass by unscrewing its mounting screw
- Hold the bulb, press inside and rotate anticlockwise to remove the tail light bulb from its holder.

- Replace the bulb 12V 21 / 5W.
- Assemble back the tail light in the reverse order of dismantling process.



MINOR MAINTENANCE TIPS

TRAFFICATOR BULB REPLACEMENT

- Remove the screw from the trafficator housing back side.
- Remove outer lens.
- Remove the fused bulb by pushing and turning in anticlockwise direction.
- Position the new bulb inside the holder, ensuring that the pins in the bulb, match with slots in the holder
- Push the bulb and turn clockwise direction to lock the bulb in the holder.
- Refit the trafficator cover with reflector and tighten the screw.



NOTE

Do not over tighten the screw.

MINOR MAINTENANCE TIPS

FUSE & CARRIER

- The fuse carrier is located under the rider seat.
- Remove pillion seat & rider seat.
- Open the fuse carrier lid & replace fuse as indicated inside the lid.
- Replace the required fuse with the spare fuse available in the fuse carrier.

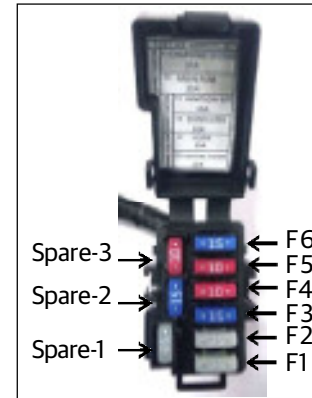

NOTE

Please ensure to replace a spare fuse in the holder at the earliest opportunity.

MINOR MAINTENANCE TIPS

BLADE FUSE USAGE LIST

ID No.	Function	Rating
F1	CHARGING FUSE	25A
F2	MAIN FUSE	25A
F3	IGNITION - EFI FUSE	15A
F4	INSTRUMENT CLUSTER/ SIGNALLING FUSE	10A

ID No.	Function	Rating
F5	HORN FUSE	10A
F6	LIGHTING FUSE	15A
SPARE-1	SPARE FUSE 1	25A
SPARE-2	SPARE FUSE 2	15A
SPARE-3	SPARE FUSE 3	10A

WARNING

Please get the electrical system of your Motorcycle checked thoroughly and get the faults corrected immediately after experiencing any fuse failure. Not doing this can result into repeated fuse failures.

Usage of fuses other than specified rating will damage the complete electrical system.

MINOR MAINTENANCE TIPS

WINDSHIELD CLEANING

Wipe the windshield with a soft cloth. Do not wipe vigorously as it will cause scratches on the windshield.

Use a mild detergent and lukewarm water to remove any hard coating, insect hits etc from the windshield.

Rinse well with water and use a soft dry and lint free cloth to wipe off the water.

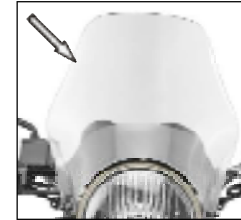

CAUTION

Use of any hard cleaning substances such as stain removers, water repellent compounds, petroleum products, solvents and alcohol based material will seriously affect the windshield transparency.

Scratches, cloudiness, cuts and abrasions on the windshield cannot be polished or removed. The windshield must only be replaced if damaged.

⚠ WARNING

Never attempt to clean the windshield while riding. Failure to do so may cause loss of control on the motorcycle, leading to a potential accident, resulting in serious injury to both rider and other road users, besides causing severe damage to the motorcycle.

LONG TRIP PRECAUTIONS

CHECKS PRIOR TO THE COMMENCEMENT OF LONG JOURNEY

- Service the motorcycle at a Royal Enfield Authorised Dealer / Service Center.
- Ensure sufficient quantity of petrol in the fuel tank for the journey planned.
- Check and correct tyre pressure if necessary.

CHECKS AFTER EVERY 1500 KMS / 932 MILES OF RUN

- Any loose fasteners.
- Condition of the tyres.
- Correct oil level in engine.
- Working of all lights and horn.
- Proper drive chain tension.

LONG TRIP PRECAUTIONS

ITEMS TO BE CARRIED

- Tool kit
- Bulbs for Head light, Trafficator light & Tail light, fuse
- Accelerator, Clutch cables.
- Rear chain master link lock assembly.
- Insulation tape.
- Spark plug, Spark plug cap.

WASHING PROCEDURE

PRECAUTIONS

- Wash motorcycle when the engine is cold.
- Cover the silencer, tail pipe, horn and control switches with suitable plastic bags and tie it firmly to prevent water entry.
- Remove ignition key and seal key hole using adhesive tape.
- Brush engine area with a solvent to remove dirt or grease.
- Use low pressure jet of water to clean.
- DO NOT spray water directly on the steering stem area as it will damage the bearings and cause the handle bar movement to become sticky.
- Never spray water with great force on head lamp, speedometer, flasher lights, front and rear wheel hubs, electrical connections and wires, control cables, spark plug, battery, side mirrors, steering stem, etc.
- Do not apply any corrosive solvent on painted surfaces or rubber parts.
- Use luke warm water and mild detergent on the painted components to remove dirt, etc.





WASHING PROCEDURE

- Rinse motorcycle thoroughly with plain water to remove the detergent.
- If possible, use compressed air and blow off water particles from the hard to reach areas of the motorcycle, electrical connections etc.
- No direct jet at the edges of decal, electrical parts, coupler joints, silencer tail pipe, radiator lubrication points like steering cone kit, brake pedal, wheel bearings, chain, brake cam & swing arm bushes to be washed in spray mode only (not in jet mode).



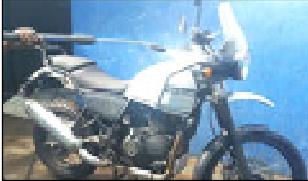

AFTER WASHING

- Ensure, the motorcycle is thoroughly dry by wiping with a clean soft absorbent cloth or chamois leather.
- Remove all plastic bags and adhesive tapes.
- Lubricate control cables, pivot and rear chain with lube oil.
- Polish the painted (**except Stone Black Colour / Matt paint finish**) and plated surfaces using polishing wax.
- Start engine and allow to run at idling speed for a few minutes to warm up engine.
- Drive the motorcycle slowly, applying both brakes intermittently to dry up the water in the brake shoes.

WASHING PROCEDURE

Location	Do's	Don'ts
<p>Steering T Stem Mounting area</p>	<p>Wipe Steering area with Cotton Cloth.</p> 	<p> WARNING</p> <p> Do not spray high pressure water on top & bottom dust seal area, as shown.</p> <p>Wet a small piece of cloth and gently rub on required areas, to clean the steering tube area.</p>  

WASHING PROCEDURE

Location	Do's	Don'ts
Oil Cooler Fins Damage	Use protector to cover the fins Location 	Don't use High pressure water jet on Oil Cooler 
Instrument Cluster	Wipe Head lamp glass with Cotton Cloth 	Don't use High pressure Water on Head lamp Front & back 

NOTE

High pressure water Jet should not directly Shown on the above mentioned Locations

WASHING PROCEDURE

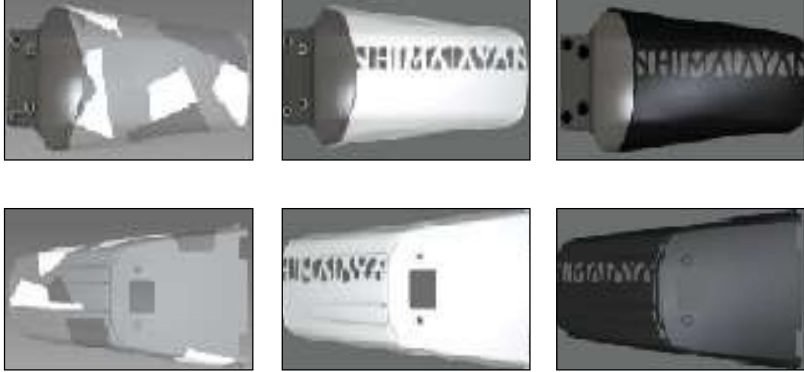
Location	Note
<p>Stickers on Front Mudguard & Rear Mudguard</p>	<p>High pressure water Jet should not directly Shown on these Locations.</p> 

STORAGE PRECAUTIONS

In case your Motorcycle is not going to be used for a month or more, the following precautions should be taken.

- Get the motorcycle serviced through a Royal Enfield Authorised Dealer / Service Center.
- Drain fuel tank and fuel line.
- Spray engine oil inside the fuel tank to prevent rusting.
- Remove spark plug. Pour in about 25ml of clean engine oil through spark plug hole. Close the hole and crank engine several times and refit spark plug.
- Clean rear chain thoroughly and apply a chain lube.
- Remove battery from the motorcycle. Clean the terminals free of corrosion and apply petroleum jelly to terminals.
- Store the battery in a cool, dry and well ventilated place.
- Cover the silencer with plastic bags to prevent moisture entry. Set the motorcycle on its center stand.
- Apply anti rust solutions on all plated parts. Take care not to apply this solution on rubber or painted parts.
- Store motorcycle in a clean covered area free of moisture and dust.
- For re use after storage, it is preferable to get the motorcycle prepared through a Royal Enfield Authorised Dealer / Service Center to ensure the motorcycle is restored to its peak operating conditions.
- If the motorcycle is not used for a month or longer, It is advised to disconnect battery terminals and remove the battery. Before refitting the battery in the motorcycle, check the battery voltage is within specification, if not, recharge it from authorized service workshop / battery dealer.

WIRING DIAGRAM - HIMALAYAN

HIMALAYAN EFI WIRING HARNESS SCHEMATICS + AHO

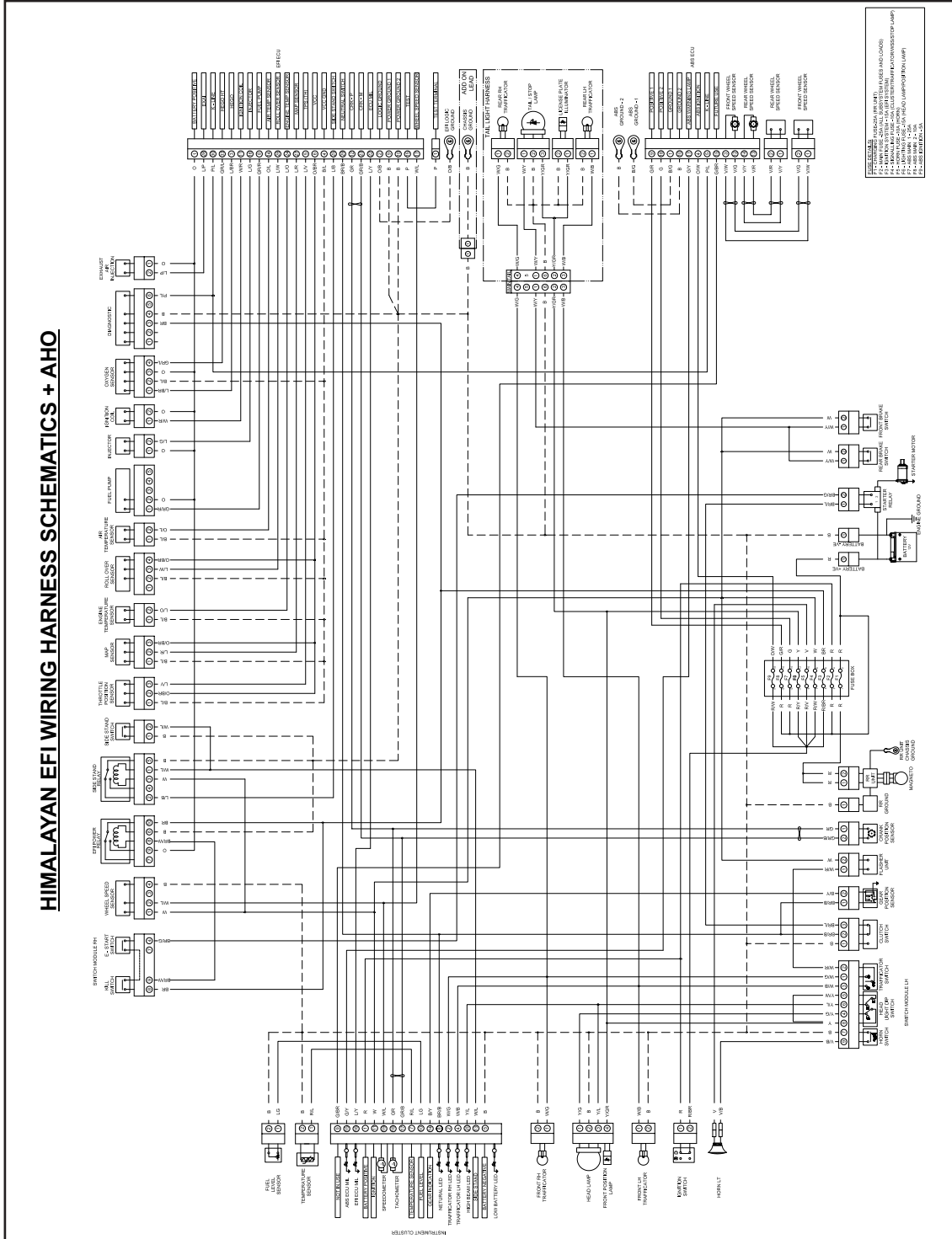

WIRING DIAGRAM - HIMALAYAN

HIMALAYAN EFI WIRING HARNESS - HORN SYSTEM

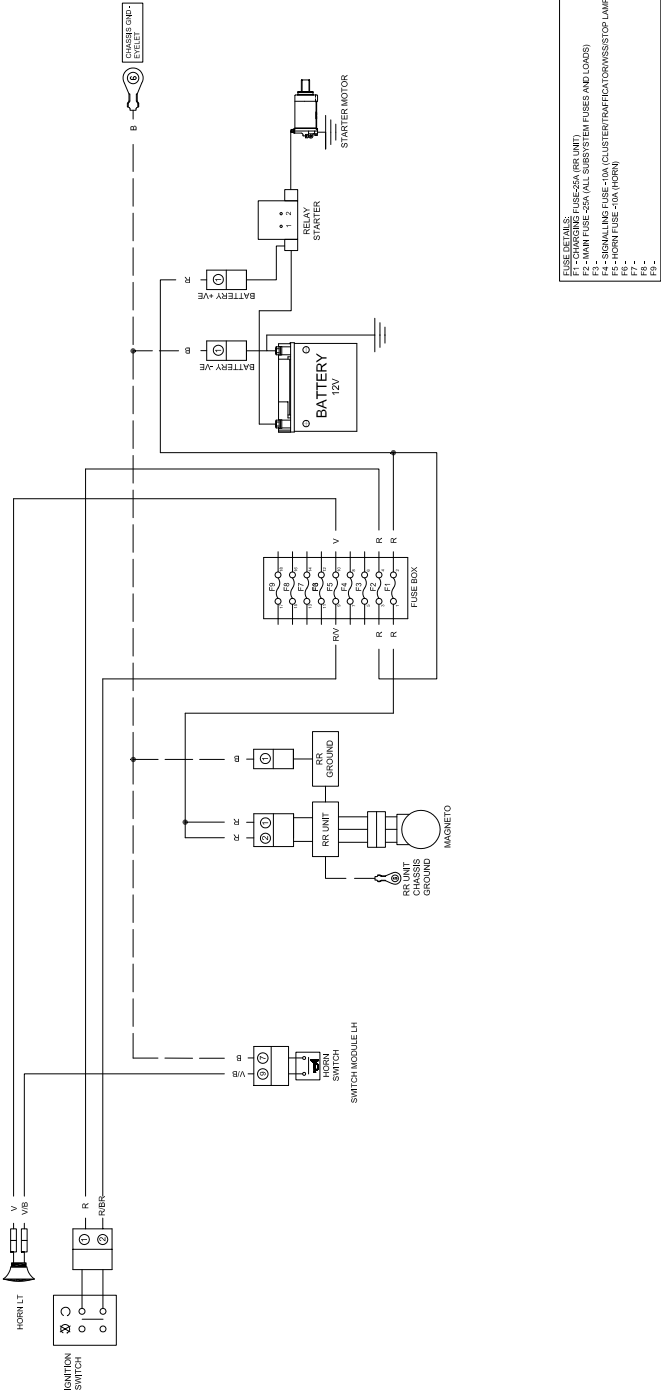

WIRING DIAGRAM - HIMALAYAN

HIMALAYAN EFI WIRING HARNESS - LIGHTING SYSTEM

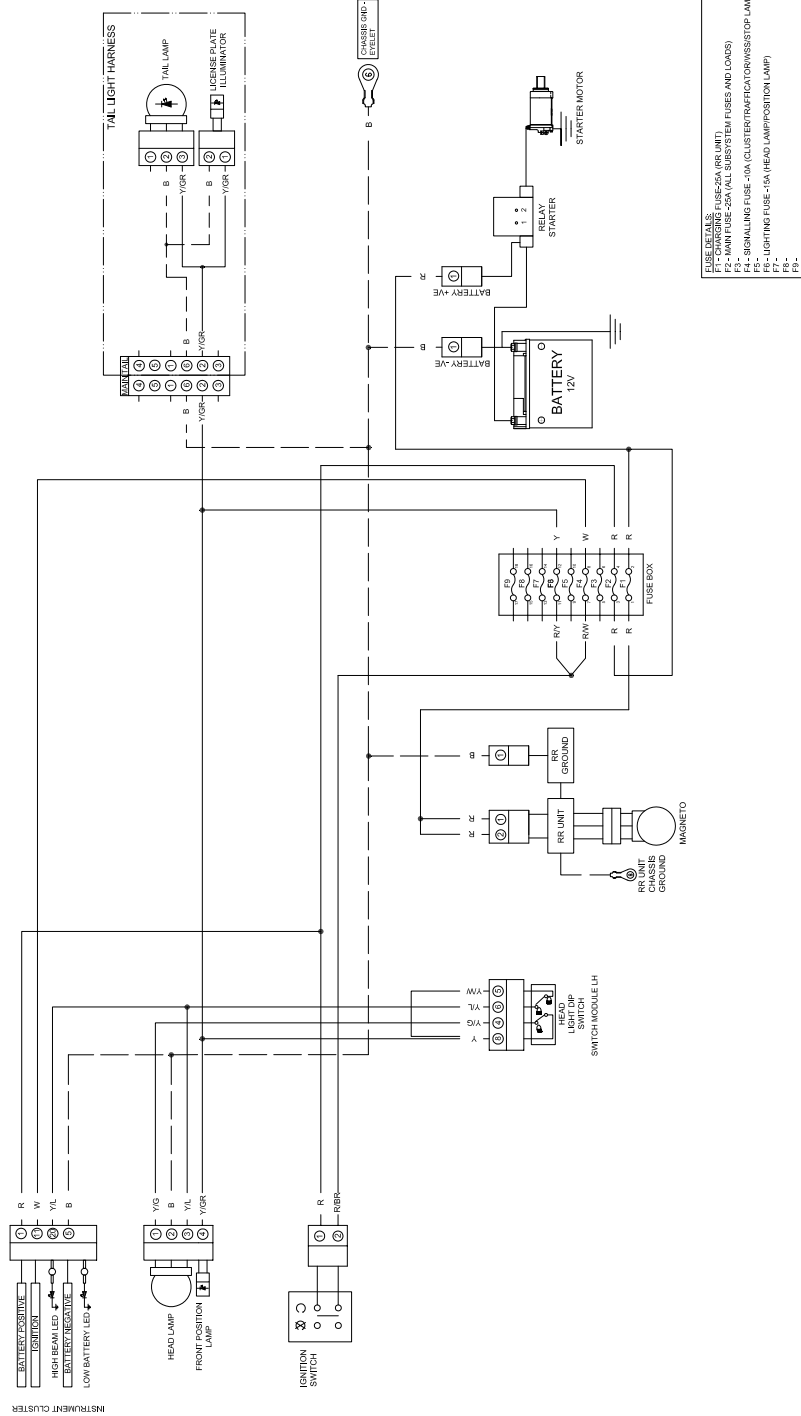

WIRING DIAGRAM - HIMALAYAN

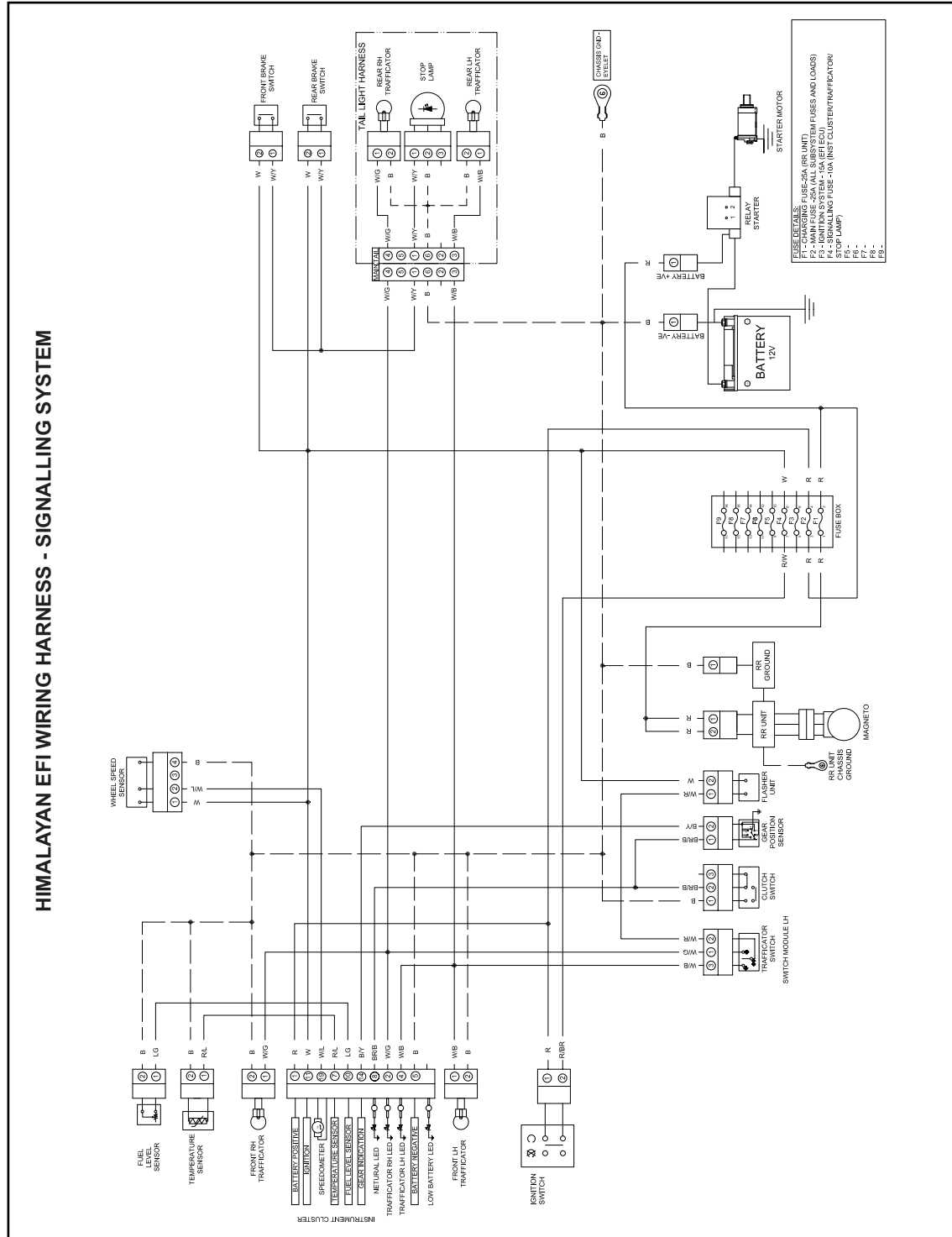

WIRING DIAGRAM - HIMALAYAN

HIMALAYAN WIRING HARNESS - STARTING, CHARGING & IGNITION (EFI) SYSTEM

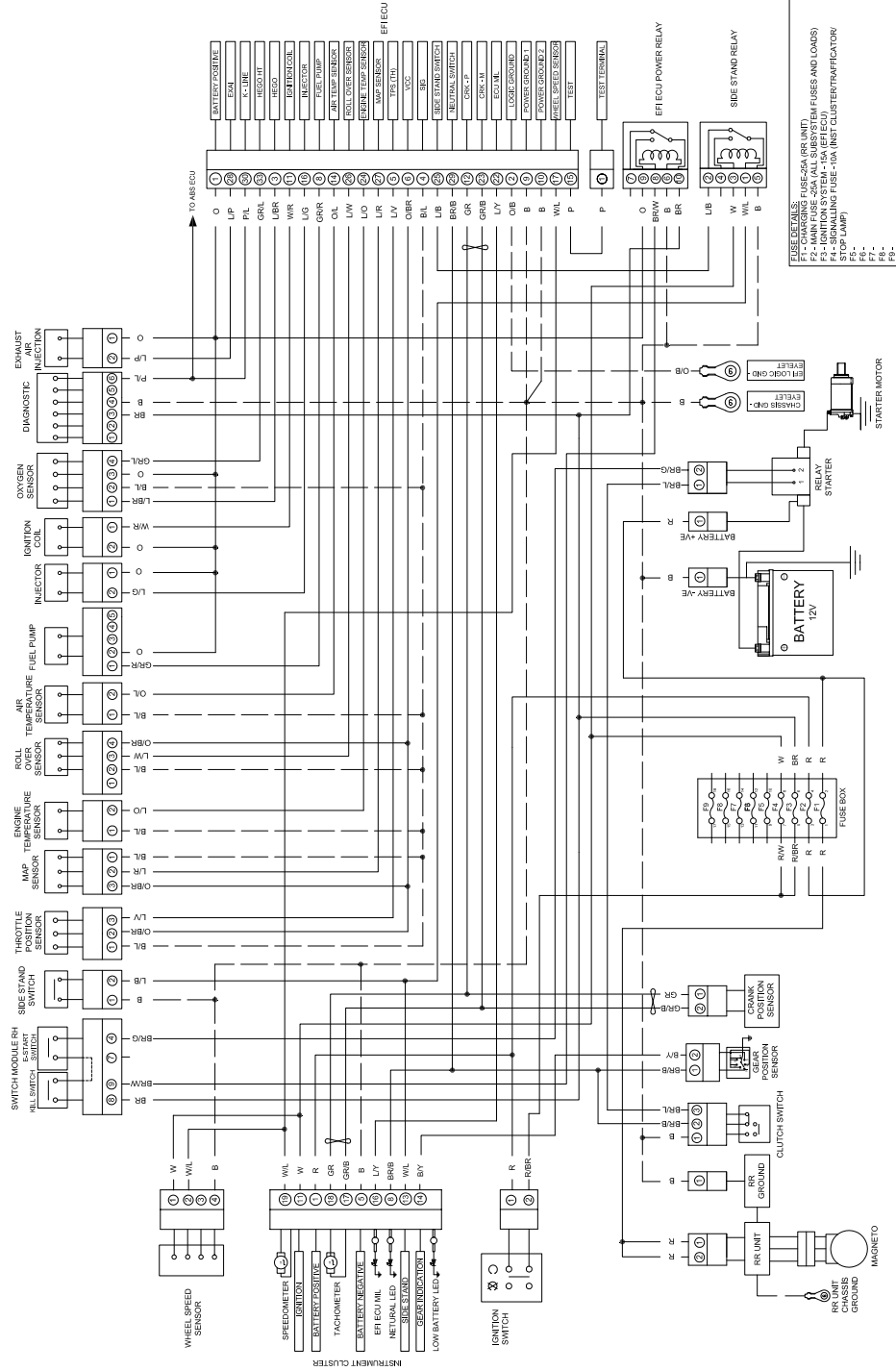

TROUBLE SHOOTING

We have listed below a few basic checks in case your motorcycle is not functioning. If in case the problem is not rectified after these checks, it is necessary to get the motorcycle checked by a Royal Enfield Authorised Dealer / Service Center to rectify the problem and to ensure trouble free performance.

Symptom	Observations	Check for / Remedy
Engine Does not start	1. Ignition/Engine stop switch is in 'OFF' position	Switch 'ON' Ignition / Engine stop switch.
	2. Very low / No fuel in the fuel tank.	Fill Fuel
	3. Lights / horn very dim	Weak/Discharged battery. Replace Battery.
	4. Electricals not working	1. Battery completely dead. Replace battery. 2. Fuse Blown. Replace appropriate fuse. Note: If fuse blows again, contact Authorised Service Center.

TROUBLE SHOOTING

Symptom	Observations	Check for / Remedy
Engine Does not start	5. Engine Cranking but not starting	Spark plug Cap/wire disconnected. Reconnect. Check if SIDE STAND is ON / SIDE STAND SWITCH MALFUNCTION. Check if gear is engaged and the side stand is down. If the ambient Temperature is low use Manual Bi-starter.
Engine Starts BUT shuts off immediatley	Engine shuts off as soon as throttle is closed.	Idling RPM set too low / setting disturbed. Contact Authorised Service Center for resetting the Idling RPM. Check if the MIL Lamp is glowing; If yes, Contact Authorised Service Center.

TROUBLE SHOOTING

Symptom	Observations	Check for / Remedy
Engine Misfires & Runs Erratically/ Stops	1. Typically happens after a Refill / Adulterated / Water in Fuel	Drain out entire fuel and Refill with fresh fuel from a reputed filling station.
	2. Motorcycle driven in Low gear / High RPM / Crowded places for long time.	Excessive Engine temperature. Switch OFF Engine and allow to cool down. Check if the MIL Lamp is glowing; If yes, Contact Authorised Service Center

TROUBLE SHOOTING

Symptom	Observations	Check for / Remedy
Poor Pickup	Engine RPM raises disproportionately to motorcycle speed	Clutch is Slipping. Check for sticky clutch / clutch not having any free play.
	Rear Chain excessively loose causing chain to slip on Sprocket.	Adjust Rear chain to correct tension. Check if the MIL Lamp is glowing; If yes, Contact Authorised Service Center.

WARRANTY TERMS & CONDITIONS

Royal Enfield Motorcycles are manufactured by following best Quality practices in respect of the material and workmanship.

Royal Enfield (RE) warrants its motorcycle to be free from manufacturing and material defect under normal use subject to following conditions.

1. Warranty shall be in force until the expiry of a period of 24 months from the date of sale. The Warranty period begins from the date of retail sales invoice of the Motorcycle to the first owner. The retail invoice date is considered as start date for the warranty period. Once the warranty period has begun, it cannot be stopped or interrupted.
2. In order to effect Warranty, it is a prerequisite that the maintenance schedule prescribed by Royal Enfield in this Owner's manual and warranty repairs if any, has been carried out at the Authorised Distributor's service facility OR at their Authorised dealership's service facility.
3. Record of all the regular services and periodical maintenance that have been carried out, along with proof of service history will be required to be verified by the Authorised Distributor's service facility OR their Authorised dealership's service facility, prior to carrying out a warranty service.

WARRANTY TERMS & CONDITIONS

4. Proof of Ownership, in the form of Sales Registration OR Proof of Purchase documentation of the motorcycle, clearly mentioning the Engine & VIN numbers, must be provided to the Distributor's service facility OR their Authorised dealership's service facility.
5. During the warranty period, RE's obligations shall be limited to repairing/replacing part(s) of the motorcycle for free, only if the part(s), on examination is deemed to have a manufacturing defect. Defective part(s) which have been replaced will become the sole property of RE.
6. Consumables like Oil, Oil Filter, Fuel etc used during warranty repair / replacement are not covered and chargeable to the customer.
7. Claims on proprietary items like tyres, tubes, spark plug, battery etc. should be taken up with the respective manufacturer or their authorised agents in the area directly by the customer. RE shall not be liable in any manner to replace them through their dealers. RE will, however, provide assistance in referring such claims on the respective manufacturer.

WARRANTY TERMS & CONDITIONS

8. Warranty shall not apply to:
- (a) Normal ageing, deterioration or rusting of plated parts, paints coat, rubber parts, soft items, glass items, plastic parts etc.
 - (b) Components like fuel filter, oil filter, air filter paper element, control cables, brake shoes / brake pads, clutch plates, drive chain & sprocket kit, steering ball races, electrical equipment, wiring harness etc., which are subjected to normal wear and tear.
 - (c) Failures occurred due to use of non recommended grade lubricants, fuel or improper level.
 - (d) Damages due to use of non-genuine parts, lack of proper maintenance, incorrect riding habits.
 - (e) Damages to engine management system parts (like ECU, Throttle body, Sensors, etc.) due to tampering which affects the performance of the motorcycle.
 - (f) Parts damaged due to accidents, collision, abuse etc.
 - (g) Irregularities not recognised as affecting the quality or function of the motorcycle such as slight vibration, oil leakage, blue discoloration of exhaust bent pipe / silencer / soft or hard shockabsorber etc.

WARRANTY TERMS & CONDITIONS

- (h) Defects arising from fitment of unauthorised or additional electrical loads.
 - (i) Motorcycle serviced or repaired at unauthorised service centers.
 - (j) Motorcycle used for competitions / racing / Stage Rallying etc.
 - (k) Electrical component like bulbs, fuses etc. and electronic components failure due to repairs by arc welding.
 - (l) Normal maintenance operations like adjustment of brakes, cleaning fuel system, engine tune-up and other such adjustments.
 - (m) Oxidization of buffed / painted / powder coated items etc.
9. Use only Royal Enfield approved parts and accessories. Use of certain other manufacturer's performance parts will void your new motorcycle warranty.
10. RE reserves the right to finally decide on all warranty claims.
11. RE reserves the right to make changes in design of the motorcycle without any obligation to install these changes on previously supplied motorcycles.

EMISSION CONTROL SYSTEM WARRANTY

The following warranty applies to the emission control system and is in addition to the LIMITED WARRANTY, NOISE CONTROL SYSTEM WARRANTY & CALIFORNIA AIR RESOURCES BOARD REGULATIONS. EVAPORATIVE EMISSION CONTROL SYSTEM WARRANTY. (Applicable only for motorcycles sold within the state of California.)

Royal Enfield Motors warrants the first owner and each subsequent owner, that this motorcycle is designed and built so as to conform, at the time of sale, with applicable regulations specified by the U.S. Federal Environmental Protection Agency and California Air Resources Board Regulations, that the Emission control system related parts fitted to this motorcycle are free from defects in materials and workmanship which may cause this motorcycle not to meet the U.S. Federal Environmental Protection Agency standards for a period of 5 years OR 18,641 Miles (30,000 Kms.), whichever occurs first, from the date of first use of the motorcycle.

The Warranty period shall begin, on the date the motorcycle is delivered to the first retail purchaser OR from the first date the motorcycle is used as a demonstrator OR as a display and/or trial motorcycle.

THE FOLLOWING ITEMS ARE NOT COVERED BY THE EMISSION CONTROL SYSTEM WARRANTY:

1. Failures which may arise as a result of misuse, alterations, accidents OR non performance of routine maintenance, as specified in the Owner's Manual.

EMISSION CONTROL SYSTEM WARRANTY

2. Replacement of parts such as Spark plugs, Air filter, fuel filter, Oil filter, fuel injector, lubricating oils etc that are required to be replaced during routine maintenance at specified intervals as mentioned in this Owner's Manual.
3. Loss of time, inconvenience, loss of motorcycle use or any other consequential loss or damages.
4. Any motorcycle in which the Odometer has been tampered with, OR the speedo cable has been disconnected for any reason Or is broken and not replaced immediately, due to which the exact distance covered cannot be determined.

RECOMMENDATIONS FOR REQUIRED MAINTENANCE:

IT IS RECOMMENDED THAT THE ROUTINE MAINTENANCE OF THE MOTORCYCLE BE CARRIED OUT AT SPECIFIED INTERVALS AND ANY MAINTENANCE TO THE EMISSION CONTROL SYSTEMS SHOULD BE PERFORMED ONLY BY AN AUTHORISED ROYAL ENFIELD SERVICE DEALER AND USING ONLY GENUINE ROYAL ENFIELD SPARE PARTS.

REPAIRS TO THE EMISSION CONTROL SYSTEM MAY BE PERFORMED BY ANY OTHER QUALIFIED SERVICE OUTLET OR INDIVIDUAL AND USE OF PARTS OTHER THAN GENUINE ROYAL ENFIELD SUPPLIED PARTS IS PERMISSIBLE, ONLY IF SUCH AGENCY OR INDIVIDUALS AND THE NON GENUINE PARTS USED, ARE CERTIFIED TO COMPLY WITH THE U.S. ENVIRONMENTAL PROTECTION AGENCY STANDARDS.

NOISE CONTROL SYSTEM WARRANTY

The following warranty applies to the noise control system and is in addition to the LIMITED WARRANTY, EMISSION CONTROL SYSTEM WARRANTY & CALIFORNIA AIR RESOURCES BOARD REGULATIONS. EVAPORATIVE EMISSION CONTROL SYSTEM WARRANTY. (Applicable only for motorcycles sold within the state of California.)

Royal Enfield Motors warrants the first owner and each subsequent owner, that this motorcycle is designed and built so as to conform, at the time of sale, with applicable regulations specified by the U.S. Federal Environmental Protection Agency and California Air Resources Board Regulations, that the Noise control system emission related parts fitted to this motorcycle are free from defects in materials and workmanship which may cause this motorcycle not to meet the U.S. Federal Environmental Protection Agency standards for a period of 5 years OR 18,641 Miles (30,000 Kms.), whichever occurs first, from the date of first use of the motorcycle.

The Warranty period shall begin, on the date the motorcycle is delivered to the first retail purchaser OR from the first date the motorcycle is used as a demonstrator OR as a display and/or trial motorcycle.

THE FOLLOWING ITEMS ARE NOT COVERED BY THE NOISE CONTROL SYSTEM WARRANTY:

1. Failures which may arise as a result of misuse, alterations, accidents OR non performance of routine maintenance, as specified in the Owner's Manual.

NOISE CONTROL SYSTEM WARRANTY

2. Replacing OR removing OR modifying any portion of the NOISE CONTROL SYSTEM (consisting of Exhaust, Air intake/ cleaner assembly) with parts not certified to be genuine and noise legal in the USA for street use.
3. Loss of time, inconvenience, loss of motorcycle use or any other consequential loss or damages.
4. Any motorcycle in which the Odometer has been tampered with, OR the Speedo cable has been disconnected for any reason or is broken and not replaced immediately, due to which the exact distance covered cannot be determined.

RECOMMENDATIONS FOR REQUIRED MAINTENANCE:

IT IS RECOMMENDED THAT THE ROUTINE MAINTENANCE OF THE MOTORCYCLE BE CARRIED OUT AT SPECIFIED INTERVALS AND ANY MAINTENANCE TO THE NOISE CONTROL SYSTEMS SHOULD BE PERFORMED ONLY BY AN AUTHORISED ROYAL ENFIELD SERVICE DEALER AND USING ONLY GENUINE ROYAL ENFIELD SPARE PARTS.

REPAIRS TO THE NOISE CONTROL SYSTEM MAY BE PERFORMED BY ANY OTHER QUALIFIED SERVICE OUTLET OR INDIVIDUAL AND USE OF PARTS OTHER THAN GENUINE ROYAL ENFIELD SUPPLIED PARTS IS PERMISSIBLE, ONLY IF SUCH AGENCY OR INDIVIDUALS AND THE NON GENUINE PARTS USED, ARE CERTIFIED TO COMPLY WITH THE U.S. ENVIRONMENTAL PROTECTION AGENCY STANDARDS.

EVAPORATIVE EMISSION CONTROL SYSTEM WARRANTY

(Applicable only for the state of California)

The following warranty applies to the evaporative emission control system and is in addition to the LIMITED WARRANTY, EMISSION CONTROL SYSTEM WARRANTY & NOISE CONTROL SYSTEM WARRANTY.

Royal Enfield Motors warrants the first owner and each subsequent owner, that this motorcycle is designed and built so as to conform, at the time of sale, with applicable regulations specified by the California Air Resources Board AND that the evaporative emission control system related parts fitted to this motorcycle are free from defects in materials and workmanship which may cause this motorcycle not to meet applicable regulations of the California Air Resources Board standards, for a period of 5 years OR 18,641 Miles (30,000 Kms.), **whichever occurs first, from the date of first use of the motorcycle.**

The Warranty period shall begin either on the date the motorcycle is delivered to the first retail purchaser OR from the first date the motorcycle is used as a demonstrator OR as a display and/or trial motorcycle.

THE FOLLOWING ITEMS ARE NOT COVERED BY THE EVAPORATIVE EMISSION CONTROL SYSTEM WARRANTY:

1. Failures which may arise as a result of misuse, alterations, accidents OR non performance of routine maintenance, as specified in the Owner's Manual.

EVAPORATIVE EMISSION CONTROL SYSTEM WARRANTY

2. Replacing OR removing OR modifying any portion of the EVAPORATIVE EMISSION CONTROL SYSTEM (consisting of Fuel tank, fuel tank cap, Canister, purge valve, throttle body, vapor hoses, fuel hoses and hose connectors) with parts not certified to be genuine and approved by California Air Resources Board.
3. Loss of time, inconvenience, loss of motorcycle use or any other consequential loss or damages.
4. Any motorcycle in which the Odometer has been tampered with, OR the Speedo cable has been disconnected for any reason OR is broken and not replaced immediately, due to which the exact distance covered cannot be determined.
5. Normal ageing of parts such as fuel hoses, vapor hoses, gaskets & rubber components.

RECOMMENDATIONS FOR REQUIRED MAINTENANCE:

IT IS RECOMMENDED THAT THE ROUTINE MAINTENANCE OF THE MOTORCYCLE BE CARRIED OUT AT SPECIFIED INTERVALS AND ANY MAINTENANCE TO THE EVAPORATIVE EMISSION CONTROL SYSTEMS SHOULD BE PERFORMED ONLY BY AN AUTHORISED ROYAL ENFIELD SERVICE DEALER AND USING ONLY GENUINE ROYAL ENFIELD SPARE PARTS.

REPAIRS TO THE EVAPORATIVE EMISSION CONTROL SYSTEM MAY BE PERFORMED BY ANY OTHER QUALIFIED SERVICE OUTLET OR INDIVIDUAL AND USE OF PARTS OTHER THAN GENUINE ROYAL ENFIELD SUPPLIED PARTS IS PERMISSIBLE, ONLY IF SUCH AGENCY OR INDIVIDUALS AND THE NON GENUINE PARTS USED, ARE CERTIFIED TO COMPLY WITH THE CALIFORNIA AIR RESOURCES BOARD.

SERVICE MAINTENANCE RECORD

S.No.	Date	Job Card No.	KMS/ Miles	Brief details of work / service	Royal Enfield Authorised Dealer
1.					
2.					
3.					
4.					
5.					
6.					
7.					
8.					

SERVICE MAINTENANCE RECORD

S.No.	Date	Job Card No.	KMS/ Miles	Brief details of work / service	Royal Enfield Authorised Dealer
9.					
10.					
11.					
12.					
13.					
14.					
15.					
16.					

SERVICE MAINTENANCE RECORD

S.No.	Date	Job Card No.	KMS/ Miles	Brief details of work / service	Royal Enfield Authorised Dealer
17.					
18.					
19.					
20.					
21.					
22.					
23.					
24.					

SERVICE MAINTENANCE RECORD

S.No.	Date	Job Card No.	KMS/ Miles	Brief details of work / service	Royal Enfield Authorised Dealer
25.					
26.					
27.					
28.					
29.					
30.					
31.					
32.					

NOTES

NOTES



ROYAL ENFIELD

Part No. 1017116/A

ROYALENFIELD.COM