

**ROYAL
ENFIELD
OWNER'S
MANUAL**

HIMALAYAN

USA / CALIFORNIA

FOREWORD

Thank you for choosing the Royal Enfield Himalayan.

Your new motorcycle is the product born from Royal Enfield's vast experience of riding in the Himalayas since decades, from exhaustive testing in all conditions, and our continuous striving for superior reliability and performance.

Please read this Owner's Manual carefully before riding so that you will be thoroughly familiar with the proper operation of the Himalayan's controls, its features and capabilities.

To ensure a long and trouble-free life for your motorcycle, give it the proper care and maintenance described in this manual. This Owner's Manual should be considered a permanent part of your motorcycle and should remain with it even if your motorcycle is subsequently sold.

The Himalayan features a Tripper™ navigation system, powered by Google Maps and the Royal Enfield App. You can use it to connect your smartphone with the motorcycle through Bluetooth. To use the Tripper™ and to explore the many rides around you, install the Royal Enfield App and follow the steps to register your Himalayan.

-Team Royal Enfield.

NOTICE

All information in this manual is based on the latest product information available at the time of publication. Due to continuous improvements, there may be difference between the information in this manual and your motorcycle. Royal Enfield reserves the right to make production changes at any time without prior notice and without incurring any obligation to make the same or similar changes to motorcycles previously built or sold.

All images shown are for reference to explain and need not to be exactly the same on the model you own. Technical specifications are subject to change without prior notice.

"© Copyright 2022 Royal Enfield (A unit of Eicher Motors Ltd.). All Rights Reserved. No part of this manual shall be copied, distributed or otherwise dealt without the express permission in writing of Royal Enfield".

Disclaimer

1. Wash the motorcycle only with plain water. Do not use any cleaning agents or detergents. especially on painted surfaces, as it will cause discoloration and damage to the paint.
2. Do not polish your motorcycle as it will increase the gloss level and damage the paint.
3. Scratches or marks on painted / plastic surfaces cannot be removed OR touched up.
4. Warranty is not applicable for discoloration of the Silencer & Exhaust pipe, as it is a natural process that will happen during usage.

Toll Free No : 1-866-600-1122

Email ID : U.Scustomerservice@royalenfield.com

Part No. RAM00587/A / Qty / October 2022

IMPORTANT

United States Environment Protection laws, Federal Motor Vehicle Safety Standards and California Air Resources Board (Applicable only for motorcycles sold within the state of California.) strictly prohibits tampering with the Exhaust Emission Control, Noise Control and Evaporative Emission Control systems:

We would like to emphasize that any repairs to the induction, emission, exhaust and evaporative systems must be performed only by a Royal Enfield Authorised Dealer so that the motorcycle confirms to the United States Environment Protection laws, Federal Motor Vehicle Safety

Standards and California Air Resources Board regulation (Applicable only for motorcycles sold within the state of California.) It is the responsibility of the Owner / User of the motorcycle to read this manual carefully and to comply with the safety guidelines, operating instructions, and periodical maintenance instructions given here. Keep this manual in a convenient place for easy reference. DO NOT use the motorcycle until you have become familiar with this motorcycle and after reading and understanding this manual completely. In case you need any further clarifications, please contact a Royal Enfield Authorised Dealer, nearest to you, for assistance.

If your motorcycle is being used by a friend, relative, or any other person, it is your responsibility to make certain that they have completely understood the operating procedures of the motorcycle, and the contents in this manual with particular reference to the safety aspects, before riding your motorcycle.

The motorcycle is designed for NORMAL ON ROAD USE ONLY. Operation in off-road usage in some areas may be illegal and could be dangerous. Please obey local laws and regulations.

In the event of your motorcycle being sold to another person, it is your responsibility to handover this manual along with the motorcycle to the new owner.

REPORTING SAFETY DEFECTS

If you believe your motorcycle has a defect which could cause a crash and result in serious injury or loss of life, you should immediately contact the National Highway Traffic Safety Administration (NHTSA) in addition to notifying Royal Enfield North America Limited, 226 N Water St., Milwaukee WI 53202 US.

If NHTSA receives similar complaints, it may open an investigation and if it finds that a safety defect exists in a group of vehicles, it may order a recall and remedy campaign. However, NHTSA cannot become involved in any individual problems between you, and your dealer or Royal Enfield North America Limited.

To contact NHTSA you may call the Auto Safety Hotline toll-free within the United States on 1-800-424-9393 or write to: NHTSA, 400 Seventh Street SW, Washington, DC 20590. You can also obtain other information about motor vehicle safety from the hotline.

CONTENTS

Safety definitions	6	Minor maintenance tips	57
Personal and motorcycle information	7	Shock Absorber	77
Safe & Happy riding.....	8	Off Roding	78
Rules of the road	11	Long trip precautions.....	79
Cargo & Accessories.....	13	Washing procedure.....	80
Technical specifications	15	Storage precautions	82
Recommended lubricants.....	21	Troubleshooting	83
Motorcycle identification numbers.....	22	Environment care.....	85
Location of key parts.....	23	Periodic maintenance	87
Operation of controls.....	26	Warranty terms and conditions	94
Warning indications and safety systems.....	48	Emission control system warranty.....	97
Pre-operational checks	51	Noise control system warranty	103
Running in period.....	52	Evaporative emission control system warranty	105
Starting.....	53	Radio Type Approval	107
Gear shifting, riding and stopping.....	54	Service / Maintenance record	108
Parking	55	Wiring diagram	109
Tools kit.....	56	Notes	110

* Click to reach directly to your choice of topics

SAFETY DEFINITIONS

The information given under the titles: Warning, Caution and Note are for your safety and for the care and safety to your motorcycle and others. Please read these carefully and if disregarded may result in injury to yourself or others and damages to the motorcycle.



WARNING

Indicates a potentially hazardous situation. Disregarding this message may result in injury to rider or other persons.

CAUTION

This message, if disregarded, will result in damage to the motorcycle.

NOTE

Indicates important and useful messages for better understanding.

PERSONAL & MOTOR CYCLE INFORMATION

Name																				
Door No. / Street																				
Locality / Town																				
City											Country									
Contact No.	Res :										Off :									
	Mobile :										Email :									
Licence No.											Valid till :									
Model											Color :									
Engine No.																				
VIN. No.																				
Tyre make	Front :										Rear :									
Tyre Nos.	Front :										Rear :									
Battery make											Battery No.									
Sold by																				
Date of Sale																				

SAFE & HAPPY RIDING

1. Please read this manual carefully to get to know the motorcycle and its maintenance schedules.
2. Please exercise utmost caution while refueling. Open the lid carefully and slowly. Refuel only in a well ventilated area with the ignition switched "OFF".
3. Gasoline is highly explosive and inflammable. Do not smoke or refuel if there are any naked flames or sparks nearby. Switch "OFF" mobile phones and other hand held electronic devices.
4. Know and respect the rules of the road. Please be a safe rider for your own safety and for other road users.
5. Please ride your motorcycle defensively. Remember a motorcycle does not afford the same protection as an automobile.
6. Ride only at moderate speeds and out of traffic until you have become familiar with the handling characteristics of your motorcycle under all conditions.
7. Do not exceed the legal speed limit. Always reduce speed when poor driving conditions exist. Use extra caution when approaching and passing through intersections since intersections are the most likely places where accidents happen.
8. Ride where other motorists can easily spot you. Please do not ride in another motorist's "blind spot".
9. Always signal well in advance before turning or changing lanes. Make sure that other motorists can see your signaling and slow down.
10. Never ride under the influence of alcohol or other drugs that might affect your riding skills reflex.
11. When riding with pillion rider, it is your responsibility to instruct them on proper riding procedures and riding gear.
12. If you are a new rider we recommend that you obtain formal training on correct motorcycle riding techniques. New riders should gain experience under various conditions while driving at moderate speeds. Pay strict attention to road surfaces and wind conditions.
13. Do not allow other individuals, under any circumstances, to operate your motorcycle unless you know they are experienced, licensed riders and are thoroughly familiar with the operating conditions of your motorcycle.

SAFE & HAPPY RIDING

RIDING GEAR

1. Motorcycle riding pants and jacket fitted with certified armour.
2. Motorcycle riding boots.
3. Motorcycle riding gloves.
4. ISI, DOT or SNELL certified helmet as applicable for rider and pillion.
5. Wear a brightly colored jacket
6. Never wear loose-fitting clothes; otherwise they could catch on the control levers, footrests or wheels and cause injury or an accident.
7. Always wear protective clothing that covers your legs, ankles and feet. The engine or exhaust system become very hot during or after operation and can cause burns.

CAUTION

Avoid any contact with the exhaust system. The exhaust system gets very hot and remains hot for a long time after parking the motorcycle. Wear clothing that will completely cover the legs while riding. Failure to do so will result in serious burn injuries.

SAFE & HAPPY RIDING

SITTING POSTURE

Correct sitting posture is a must for stable and safe riding.

1. Sit with your shoulders completely relaxed.
2. Do not lock your elbows and retain them at a slight bend to enable maneuvering.
3. Hold the handle grip close to its inner end.
4. Lightly grip the fuel tank with your knees.
5. Keep your toes in "straight ahead" direction.
6. Before turning, look extensively in the rear view mirror, without turning your head.

BRAKING

1. Apply front and rear brakes gently and simultaneously for maximum braking efficiency.
2. Please use utmost caution while applying brakes, especially while riding under wet or bad road conditions.



WARNING

The hydraulic disc brakes fitted on your motorcycle requires very less effort. Applying any one of the brakes suddenly will lock the wheels. Failure to adhere to this warning will cause loss of control of the motorcycle, leading to a potential accident, resulting in serious injury to both rider and other road users, besides causing severe damage to the motorcycle.



WARNING

Brake pad wear will be increased if the motorcycle is used frequently off-road. Always inspect the brake pads more frequently if the motorcycle is used off-road & replace the brake pads before they become worn to or beyond the minimum service thickness. Riding the worn brake pads will reduce braking efficiency, leading to loss of motorcycle control and an accident.

Do not place the foot on the brake pedal while riding unless braking is required. Because this will lead to premature wear of brake pad.

RULES OF THE ROAD

1. Be sure your number plate is installed in the position specified by law and is clearly visible at all times.
2. Ride at a safe speed that is consistent with the type of road surface you are on. Pay strict attention to whether the surface is:
 - Dry
 - Oily
 - Icy
 - Wet
3. Watch for loose debris, such as leaves, slippery substances or loose gravel that can hamper the stability of your vehicle.
4. Do not exceed the legal speed limit or drive too fast for existing conditions. Always reduce speed when poor driving conditions exist. High speed increases the influence of any other condition affecting stability and increases the possibility of loss of control.
5. Keep to the correct side of the road center line when meeting oncoming vehicle.
6. All traffic signs including manual controls at intersections, should be obeyed promptly slow down at traffic signs near schools and caution signs at rail road crossings.
7. When intending to turn signal at least 100 ft (30.5 m) before reaching the turning. Be close to the center line (unless local rules require otherwise), slow down and then turn carefully.
8. Never jump a traffic light. When a change is imminent from GO to STOP (or vice versa) at intersections, slow down and wait for the light to change to green. Never run through a yellow or red traffic light.
9. Do not leave the curb or parking area without signaling. Be sure your way is clear to enter moving traffic. A moving line of traffic always has the right-of-way.

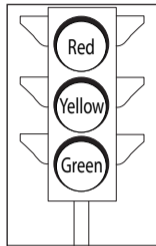

RULES OF THE ROAD

1. When parking the motorcycle, park on a firm and flat surface to prevent it from falling over.
2. Protect your motorcycle against theft. After parking your motorcycle, ensure that the steering head is locked and then remove the ignition key.

SIDE VIEW MIRRORS

Your motorcycle is equipped with convex mirrors and have a curved surface. This type of mirror is designed to give a much wider view of the rear than a normal flat mirror. However, vehicles and other objects seen in this type of mirror will look smaller and farther away than when seen in a flat mirror.

Use care when judging the size or distance of vehicles/objects seen in these mirrors.

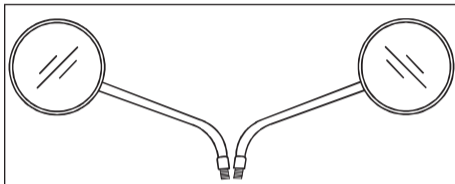

NOTE

To establish the relative distance of vehicles/objects behind your motorcycle through the mirrors, adjust each mirror in such a way, that a small portion of your shoulder is visible and a large portion behind your motorcycle is seen clearly with reference to your riding posture.

CARGO & ACCESSORIES

LOADING

1. Please do not fit non original equipments or non genuine accessories as they will cause damage to the motorcycle and also affect the riding and handling of the motorcycle.
2. Please ensure cargo is securely strapped to the rear and sides of the motorcycle and do not become loose or shift while riding.
3. Ensure the weight is distributed evenly on both sides of the motorcycle.
4. Do not carry excessively heavy or huge cargo on the motorcycle.
5. The maximum permissible weight of the pannier box is 5 kg each side.

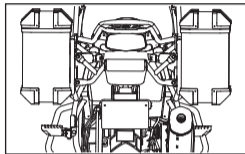

6. Do not hang any items on the handle bar and luggage carrier while riding which will lead to damage for the parts nearby.



WARNING

Please exercise utmost caution while carrying cargo or luggage on the motorcycle. Failure to adhere to the above precautions can cause loss of control on the motorcycle leading to a potential accident, resulting in serious injury to both rider and other road users, besides causing severe damage to the motorcycle.

Total weight of the rider and any passenger accessories and luggage must not exceed the maximum load limit.

CARGO & ACCESSORIES

CAUTION

Exhaust gases contains poisonous carbon monoxide and chemicals, known to cause cancer, birth defects or other reproductive defects. Please park the motorcycle only in a well ventilated area and do not stay in the same place where the motorcycle is parked, especially when the engine and exhaust system are hot.



WARNING

Do not tow a disabled motorcycle. The steering and handling of the motorcycle will be impaired due to the force of the towline. Towing a motorcycle can cause loss of control on the motorcycle, leading to a potential accident resulting in serious injury to both rider and other road users besides causing severe damage to the motorcycle.



WARNING

Do not attach a trailer to the motorcycle attaching a trailer can cause loss of control on the motorcycle, leading to a potential accident, resulting in serious injury to both rider and other road users, besides causing severe damage to the motorcycle.



WARNING

Max load on grab rail not to exceed 7 kg.

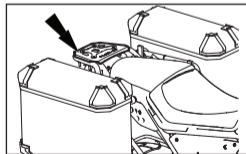

TECHNICAL SPECIFICATIONS

ENGINE

Engine type	Single cylinder, 4 Stroke, SOHC, Air cooled, Fuel injection
Bore	78 mm
Stroke	86 mm
Displacement.....	410.94 cc
Compression ratio....	9.5:1
Max power	17.88 kW @ 6500 rpm
Max torque	32 Nm @ 4250 ± 250 rpm
Idle rpm.....	1300 ± 100 rpm
Starting system	Electric Start
Air filter element	Paper element

Lubrication	Forced Lubrication, Wetsump
Engine oil capacity.....	2.3 L (Initial fill only), 1.6 - 1.8 L (Subsequent refills)
Cooling	Air cooled with Oil cooler

IGNITION SYSTEM

Ignition system	Electronic ECU / Variable
Spark plug	Bosch - UR5CC
Spark plug gap	0.7 to 0.8 mm

TECHNICAL SPECIFICATIONS

TRANSMISSION

Clutch..... Wet multi plates

Secondary drive 5/8" Chain & sprocket

Primary drive..... Gear

Secondary ratio 2.533:1

Primary ratio 2.312:1

Drive chain links 110 links

Gear box..... 5 Speed, Constant mesh

Gear Ratios

1st Gear 1st 2.916:1

2nd Gear..... 2nd 1.833:1

3rd Gear..... 3rd 1.428:1

4th Gear..... 4th 1.173:1

5th Gear..... 5th 1.000:1

TECHNICAL SPECIFICATIONS

CHASSIS

Frame Half duplex split cradle

Steering lock In built

Suspension

Front..... Telescopic, Hydraulic damping,
Front wheel travel : 200 mm

Rear..... Swing arm with Linkage type Hy-
draulic damping mono shock,
Rear wheel travel : 180 mm

Brakes

Brake system..... Dual channel ABS (Switchable to
Single channel ABS - Rear wheel
ABS control deactivation)

Front disc..... 300 mm Dia disc.

Rear disc 240 mm Dia disc.

Tyre size

Type of wheels	Standard size
Front	90/90-21 54S
Rear	120/90-17 64S

Tyre pressures

Type of wheels	Solo	With pillion
Front	25 psi / 1.75 kg/cm ²	27 psi/ 1.89 kg/cm ²
Rear	32 psi/ 2.25 kg/cm ²	34 psi/ 2.39 kg/cm ²

TECHNICAL SPECIFICATIONS

Fuel type.....	Unleaded gasoline
Ethanol content.....	E10 or less
Minimum octane.....	91 RON (Research octane number) or Higher
Fuel tank capacity*...	15 ± 0.5 l (approx*)
Low fuel warning	Fuel guage (Red zone) 5.5 ± 0.5 l (approx*)
Dead stock	0.5 l (approx*) (unusable fuel)

* The above values are approximate and the actual capacity may vary with each fuel tank.

CAUTION

- The use of petrol containing more than the specified ethanol may cause the fuel tank corrosion & paint damage and may also damage the rubber tubes in the fuel line as well.
- It is recommended to use only unleaded petrol, as leaded petrol may cause damage to the catalytic converter.

ELECTRICALS

Fly wheel magneto	221 W @ 1500 rpm
Generation	Alternator, III Phase
System	12 V - DC
Battery	12 V, 8 Ah Maintenance free
Head lamp	12 V, H4-60/55 W - BULB
Tail lamp/ Brake lamp..	12 V - 4/1 W LED

TECHNICAL SPECIFICATIONS

Licence plate illuminator.....	12 V - LED
Front position lamp.....	12 V - LED
Speedometer lamp.....	12 V - LED
Hi beam indicator	12 V - LED
Neutral lamp telltale	12 V - LED
Turn signal telltale	12 V - LED
Turn signal.....	12 V, 10 W * 4 Nos.
Horn	12 V, 2.5 A
Starter motor	12 V, 0.7 kW
Instrument cluster	Digital cluster with LCD
Side Stand Indicator	LCD Indication
Malfunction indicator.....	12 V - LED
ABS indicator.....	12 V - LED



WARNING

Using bulbs/electrical gadgets other than specified rating may lead to overloading/erratic behaviour/premature failure of electrical system.

Modifications or fitments which are not approved by Royal Enfield, will seriously affect the performance of the vehicle and will render the warranty void.

TECHNICAL SPECIFICATIONS

DIMENSIONS

Length.....	2190 mm
Width	840 mm
Height	1370 mm
Wheel base	1465 mm
Ground clearance.	220 mm
Saddle height	800 mm

- Values/Dimensions mentioned above are for reference only.
- In view of continuous improvements being done on our motorcycles, the specifications are subject to change without prior notice.

WEIGHTS

Kerb weight (90% fuel & oil)	199 kg
Gross vehicle weight	365 kg

RECOMMENDED LUBRICANTS

ENGINE OIL		FRONT FORK OIL	BRAKE FLUID
Grade	SAE 15 W 50 API SL Grade JASO MA 2 Semi synthetic	10 W/Fork oil (Viscosity range 35)	"DOT 4"
Capacity	2.3 l (First Fill only) 1.6 - 1.8 l Approx. (during oil & filter element replacement in periodical maintenance)	455 ml/leg	Front/Rear:100 ml

NOTE

Oil level should be up to "MAX" level. Do not overfill as it will affect the clutch functioning.

CAUTION

Using non recommended/In-correct oils, can cause serious damage to the moving parts, affect performance of the motorcycle and void the warranty.

NOTE

Recommendation subject to change without notice.

MOTORCYCLE IDENTIFICATION NUMBERS -DETAILS

FRAME NUMBER

Punched on steering head tube right side.

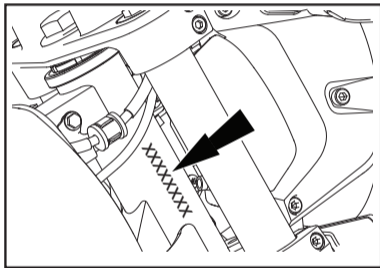

ENGINE NUMBER

Punched on crankcase top side.

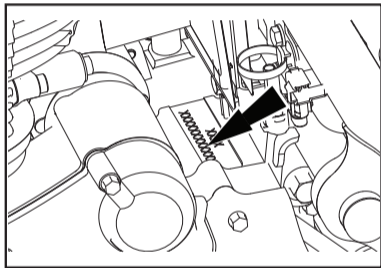

CAUTION

It is illegal to tamper with or alter the VIN/ Engine numbers of the motorcycle as it will not only be against the law but will render the vehicle registration and warranty VOID.

LOCATION OF KEY PARTS

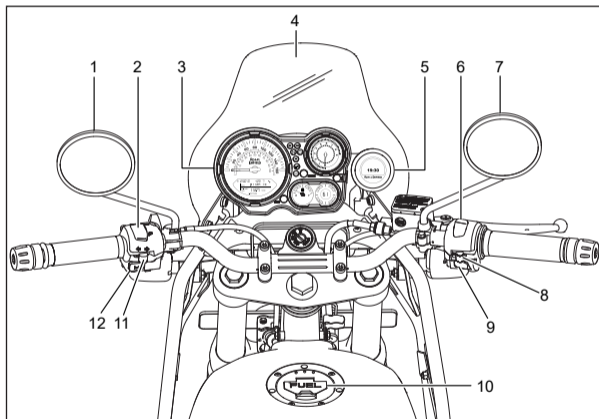

1. Rear view mirror left side
2. High beam/low beam switch
3. Instrument cluster
4. Windshield
5. Tripper (If fitted)
6. Engine stop switch
7. Rear view mirror right side
8. Hazard switch
9. Electric start switch
10. Fuel tank cap
11. Turn signal switch
12. Horn button

LOCATION OF KEY PARTS

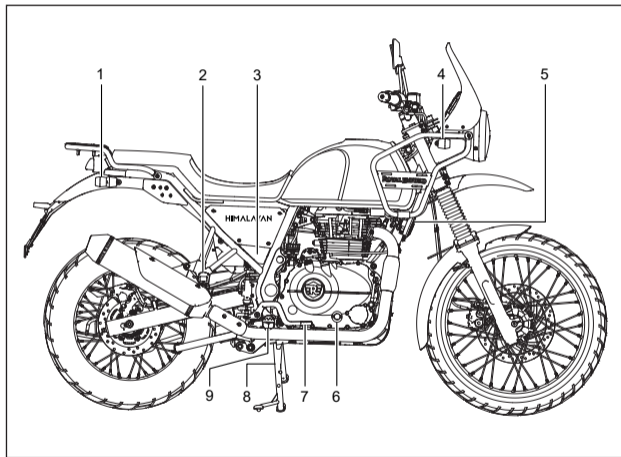

1. Right trafficator rear
2. Pillion foot rest right side
3. Right side panel
4. Right trafficator front
5. Horn
6. Oil level window
7. Rear brake pedal
8. Center stand
9. Rider foot rest right side

LOCATION OF KEY PARTS

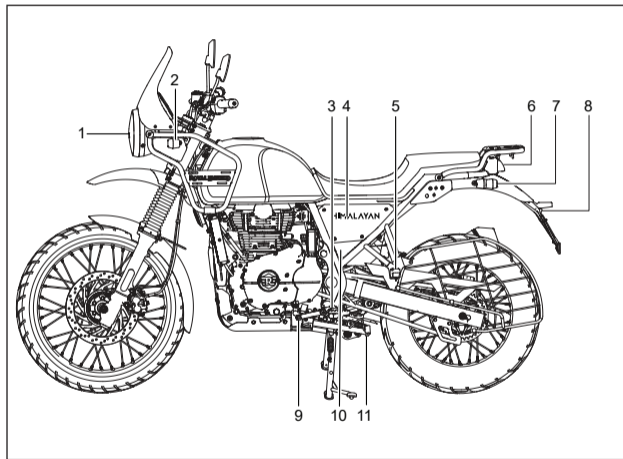

1. Headlamp
2. Left trafficator front
3. Rider foot rest left side
4. Left side panel
5. Pillion foot rest left side
6. Tail lamp
7. Left trafficator rear
8. Licence plate illuminator
9. Gear change pedal
10. Canister
11. Side stand

OPERATION OF CONTROLS

STEERING LOCK

LOCKING:

1. Turn handle bar to extreme left or right position.
2. Switch "OFF" ignition gently depress key and turn anticlockwise further till steering is locked and remove key.



UNLOCKING:

1. Insert key, turn clockwise to ignition "OFF" position. If required, gently shake handle bar to help unlock steering easily.

CAUTION

Do not force or attempt to lock/unlock steering if the handle bar is not in extreme left or right side. Failure to adhere to this caution will damage the lock and also cause the key to bend or break.



WARNING

After unlocking steering and before starting engine, check the handle bar free movement by turning to both left and right sides several times.

Failure to do so may cause unstable riding, leading to a potential accident, resulting in serious injury to both rider and other road users, besides causing severe damage to the motorcycle.

OPERATION OF CONTROLS

FUEL TANK CAP

OPENING:

1. Lift flap and insert key.
2. Turn key clockwise to enable cap to unlock and spring up.

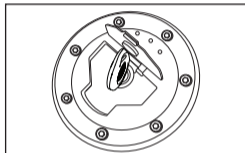

NOTE

Key cannot be removed when fuel tank cap is open.

CLOSING:

1. Gently depress cap till it is firmly locked in place and key can be removed.
2. Remove key and close flap.



WARNING

Do not overfill the fuel tank, stop filling when the fuel reaches bottom of anti-splash plate. Because fuel expands when it heats up, heat from engine or the sun can cause fuel spill out of fuel tank.

Petrol is highly explosive. Please ensure there are no open flames or sparks nearby while refueling and fill fuel tank only in a well ventilated area.

OPERATION OF CONTROLS

Please ensure petrol does not spill on painted surfaces. Wipe immediately incase fuel spills over as otherwise it will leave a permanent stain on the painted surfaces.

Anti splash plate

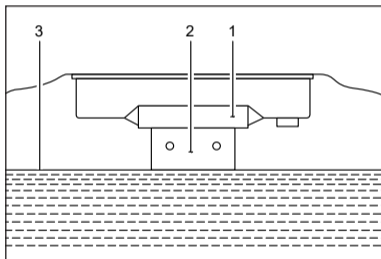

1. Fuel Filler Collar
2. Anti - Splash Plate
3. Maximum Fuel Level

IGNITION SWITCH

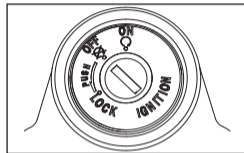

NOTE



1. Key can be removed only if ignition is in "OFF" or steering is locked.

OPERATION OF CONTROLS

WARNING

Do not switch "OFF" ignition while riding the motorcycle. Doing so can cause a potential accident, resulting in serious injury to both rider and other road users, besides causing severe damage to the motorcycle.

ENGINE STOP SWITCH

-  Engine "OFF"
-  Engine "ON"

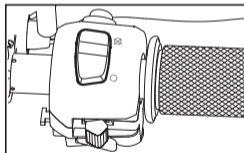

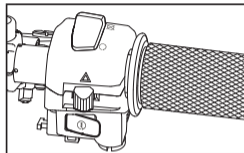

E-START SWITCH

Press & hold till engine starts.



HAZARD LIGHT SWITCH

-  Hazard light "ON"
-  OFF

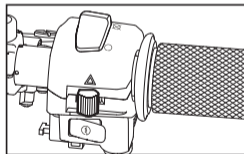

OPERATION OF CONTROLS

WARNING

1. Turn signals do not work when the hazard light switch is on.
2. All the trafficator lamps will flash simultaneously.

HORN

 Press

Press the horn button to sound horn.

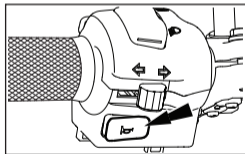

DIMMER SWITCH

 High beam

 Low beam

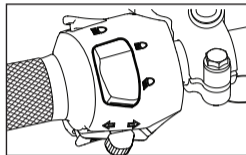

DAY FLASH

Press for Head light flash.

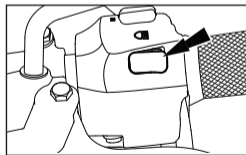

OPERATION OF CONTROLS

TURN SIGNAL SWITCH

- ← Left turn signal "ON"
- ↑ "OFF" (Push to cancel)
- ⇒ Right turn signal "ON"

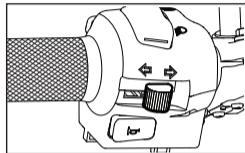

RIDER & PILLION SEAT

1. Locate key on left side & turn clock wise, lift pillion seat and remove.
2. Lift front seat from rear & remove.

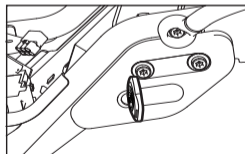

DOCUMENT HOLDER

1. Useful for storing motorcycle documents and owners manual.
2. Remove the pillion seat.
3. Gently press on top to release the tabs from the frame and open slightly.
4. To completely remove, release the bottom tabs from the frame by pulling out gently.
5. When washing the motorcycle, be careful not to flood this area with water.

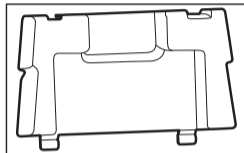

OPERATION OF CONTROLS

INSTRUMENT CLUSTER

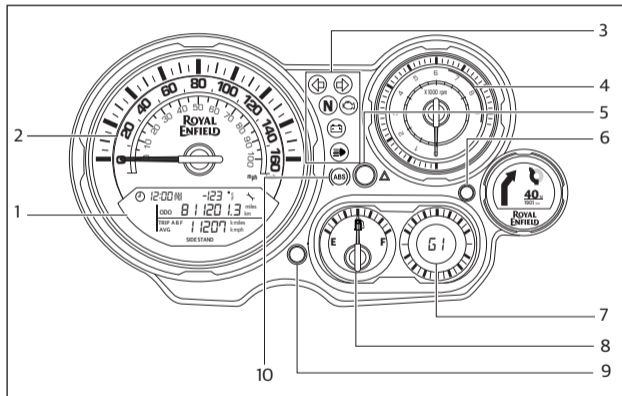

1. Main LCD
2. Speedometer (Miles major)
3. Tell tales
4. Tachometer
5. Mode button
6. Select button
7. Gear position indication
8. Fuel gauge
9. ABS Switch
10. ABS Indicator Lamp

OPERATION OF CONTROLS

MAIN LCD

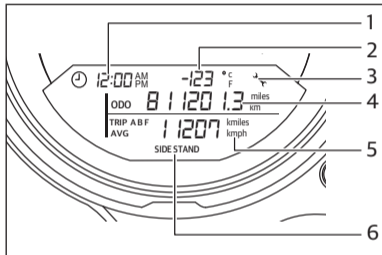

1. Clock
2. Ambient Temperature
3. Service reminder
4. Odometer
5. Trip Value (A/B & F), AVG speed A/B
6. Side Stand indication

CLOCK

1. Display in 12 hour format with AM/PM indication.
2. Will reset to 12:00 AM when battery is disconnected.



OPERATION OF CONTROLS

CLOCK SETTING

Function	Switch	Pressure time (s)	Action
CLOCK SETTING MODE	SELECT & MODE pressed with No Speed input	≥ 3 s	In ignition key 'ON' position (when vehicle not running) Enters into clock setting mode and hour digits starts to blink
	SELECT	< 1 s	Hours value shall increment by 1 accordingly for no of press
	SELECT	≥ 3 s	Hour value saved and minute digits starts to blink
	SELECT	< 1 s	Minutes value will increase by 1 by each press of the "Select" button
	SELECT	≥ 3 s	Minute value save and PM/ AM digits starts to blink
	SELECT	< 1 s	PM/ AM is interchangeable by each press of the "Select" button
	SELECT	≥ 3 s	PM/ AM save and exit from clock set mode
	NO ACTION	20 s	Auto exit without saving changes and continue with previous setting



WARNING

Never attempt to operate the select or reset buttons while riding the motorcycle. Failure to do so may cause loss of concentration and unstable riding, leading to a potential accident, resulting in serious injury to both rider and other road users, besides causing severe damage to the motorcycle.

OPERATION OF CONTROLS

AMBIENT TEMPERATURE INDICATION

1. Ambient temperature display can be changed from Celsius to Fahrenheit and vice versa.
2. The temperature indication may increase during vehicle riding/engine "ON" condition due to increase of engine temperature.
3. Ambient temperature indication tolerance is $\pm 2^{\circ}\text{C}$.

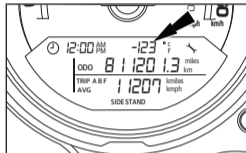

NOTE

The ambient temperature valve should be referred to only when the engine is switched "OFF" and the engine is in cold condition.

The temperature displayed will be higher if the engine is running or immediately after it is switched "OFF" since the sensor will only pick up the higher temperature surrounding it.

TEMPERATURE UNIT CHANGEOVER

Temperature sensor push button management.

Required button

- Mode

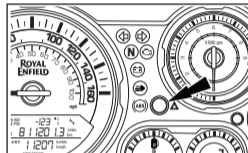

Function	Button	Pressure time (s)	Action
TEMPERATURE UNIT CHANGEOVER	MODE	≥ 10 s	In ignition key "ON" position. long press and hold "MODE" button for period ≥ 10 s to reset temperature units from degree Celsius to Fahrenheit and vice versa.

OPERATION OF CONTROLS

ABS SWITCH - ACTIVATION PROCEDURE

1. Ignition switch "ON" condition
2. Vehicle stationary
3. Press ABS switch for (3-5 s)

Single Channel ABS mode is activated (if, enabled): Rear ABS function will not work. Front wheel ABS will only work.

Procedure to Reset to Dual channel: Ignition switch reset*, vehicle will return to default dual channel ABS mode.

Dual Channel ABS mode (Default): ABS will work on bothwheels.

*Ignition key Reset: Turning ignition switch from "OFF" to "ON".

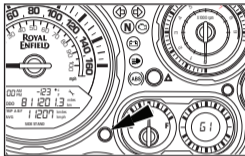

CAUTION

If Single channel ABS mode enabled, ABS only controls the front wheel. The rear wheel is not controlled by ABS and may lock during braking maneuvers.

ABS INDICATOR LAMP

- ABS indicator lamp continuously "ON" during initial check up (until or after vehicle running for a particular distance/speed) and will turn "OFF" if system is ok, then will light up again in case of any ABS system malfunction.

- Single channel mode indication: Single channel Activation with ignition key reset*: ABS tell tale will blink thrice to indicate activation. followed by ABS tell tale continuous "ON", once the vehicle is ride more than 3.1 mph (5 kmph) ABS tell tale will blink continuously.

Single channel Activation without ignition key reset*: ABS tell tale will blink continuously.

*Ignition key Reset: Turning ignition switch from "OFF" to "ON".

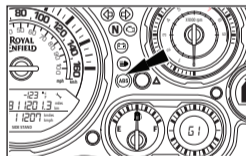

OPERATION OF CONTROLS

SERVICE REMINDER

- Service reminder is provided to remind about service due.
- Spanner symbol will flash till vehicle is serviced at service centre.
- Service reminder can be reset ONLY by authorised personnel at service centre after service is completed.
- Service reminder symbol will flash on as per below distance input from odometer.
 1. 1st service- 450 km or 279.6 mile.
 2. 2nd service - 4900 km or 3044.7 mile.
 3. From there on for every 5000 km or 3106.85 mile from previous value (ex: 9900 or 6151.5 mile, 14900 or 9258.4 mile etc.)

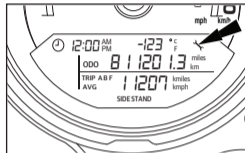

WARNING

Do not use high pressure water jet directly on instrument cluster for cleaning. Use only water spray cleaning and wipe it with soft dry cloth.

ODOMETER

1. Displays the cumulative kilometers the vehicle has covered.

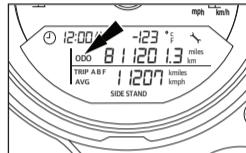

TRIP A/B & AVG SPEED A/B

- Trip A/B indicates distance travelled in particular trip.
- AvgA/B indicates average speed of vehicle in particular trip mode.

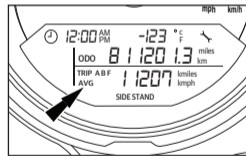

OPERATION OF CONTROLS

Function	Switch	Pressure time (s)	Action
TRIP A	SELECT	<1 s	In ignition key "ON" position, Move to: AVG A
	SELECT	>2.5 s	TRIP A/AVG A RESET
AVG A	SELECT	<1 s	Move to: TRIP B
	SELECT	>2.5 s	TRIP A/AVG A RESET
TRIP B	SELECT	<1 s	Move to: AVG B
	SELECT	>2.5 s	TRIP B/AVG B RESET
AVG B	SELECT	<1 s	Move to: TRIP A
	SELECT	>2.5 s	TRIP B/AVG B RESET

OPERATION OF CONTROLS

TRIP "F" MODE

1. The word, Trip "F" will flash when the Trip "F" mode is active.
2. Trip "F" is provided to measure distance travelled by the vehicle when fuel level in the vehicle is 5.5 ± 0.5 l in the fuel tank so that the rider can plan fuel filling accordingly based on his trip requirements, Trip "F" will get activated when needle on fuel gauge enters the red zone.
3. Trip "F" mode would come into function automatically.
4. Trip "F" mode would de-activate automatically if fuel is filled above 5.5 ± 0.5 l
5. During Trip "F" mode rider can toggle between Trip A/B but mode will return automatically to Trip "F" after 25 ± 5 s

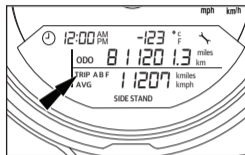

NOTE:

Trip "F" will stop displaying at approximately 90 ± 5 s. After fuel level in tank is above 5.5 ± 0.5 l, side stand is fully retracted and Ignition is switched "ON".



WARNING

Never attempt to operate the select or reset buttons while riding the motorcycle. Doing so will cause loss of concentration and unstable riding, leading to a potential accident resulting in serious injury to both rider and other road users, besides causing severe damage to the motorcycle.

SIDE STAND INDICATOR

- Indicates when side stand is extended.

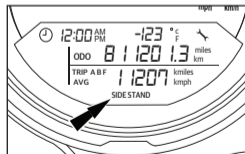

OPERATION OF CONTROLS

GEAR POSITION INDICATION

1. Displays the gear position in which the vehicle is traveling. "G" represents the Gear and "1" represents the gear position.
2. When in neutral the indication will be "N".
3. When in gear the appropriate number between 1 to 5 will be displayed.

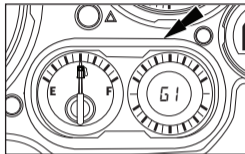

TELL TALES

1. Turn Left: Left turn signal "ON".
2. Turn right : Right turn signal "ON".
3. Neutral : Transmission is in Neutral.
4. Low Battery Indication : Indicator will glow continuously if ignition

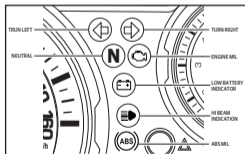

5. High Beam Indication: Head lamp high beam "ON".
6. EMS Malfunction Indication :
 - Will be illuminated as soon as ignition & stop switch are "ON" and will go "OFF" after the engine is started.
 - Will remain continuously "ON" incase of any malfunction of the EMS.
7. ABS MIL : Will be continuously "ON" during initial checkup (until or after vehicle running for a particular distance / speed) and will turn "OFF" if system is ok, then will light up again in case of any ABS system malfunction.

CAUTION

Do not run motorcycle incase the malfunction remains "ON" continuously as it can cause severe damage to the ECU & sensors. Please visit the nearest authorised Royal Enfield dealer to diagnose & rectify the defect in the EMS.

OPERATION OF CONTROLS

TACHO METER

1. Indicates the rpm at which engine is working.
2. Useful for right selection of gear with respect to engine rpm.

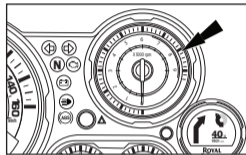

WARNING

- Do not run engine with gears in neutral as rpm will go beyond red zone.
- Do not ride motorcycle in lower gears with high acceleration as it will cause rpm to start to red zone & affect the main parts inside engine.

FUEL GAUGE

- Indicates fuel level in tank.

- The fuel pointer enters red zone. if the fuel level in the fuel tank is approximately 5.5 ± 0.5 l

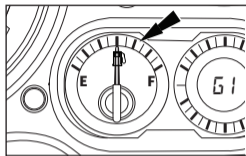

WARNING

- Do not use the motorcycle for long duration with the fuel indication in last segment blinking. Refuel at the earliest.
- Failure to do so will cause the motorcycle to run out of fuel and get stranded in addition to causing serious damage to the fuel pump.

CAUTION

- Do not run motorcycle incase the ABS Indicator lamp continuously "ON".
- The ABS indicator blink continuously to indicate single channel ABS mode is enabled.

OPERATION OF CONTROLS - TRIPPER (If fitted)

TRIPPER

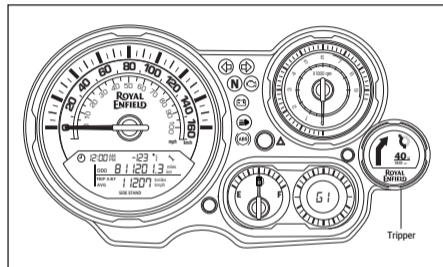

Tripper is being provided to have turn by turn navigation on motorcycle to help riders to have a hassle free riding without handling the smartphones, This device works based on bluetooth connectivity with navigation search based on RE Mobile app with the support of Google Maps.

Device is capable of showing turn by turn navigation on a custom designed round color TFT with uniquely designed arrow font designed intuitively for ease of riding.

Background display can be switched between day mode and night mode which can be selected by riders from RE Mobile app.

Scan the QR Code, to download, Install, register and to know more about the tripper.



OPERATION OF CONTROLS - TRIPPER (If fitted)

Features:

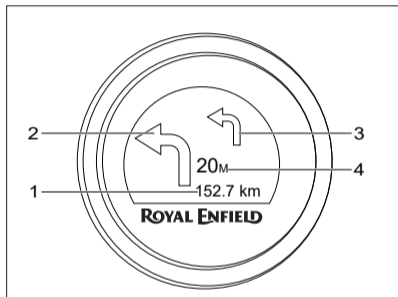

1. Distance to destination or ETA
2. Primary direction or next turn
3. Secondary direction or next to next turn
4. Distance to next turn

1. Turn by turn navigation with primary turn, secondary turn.
2. Distance to next turn, distance to destination or Estimated Time of Arrival (ETA).
3. Clock display (in case of no connectivity, no navigation input or after destination is reached).
4. User can select day and night mode (through RE mobile app only).
5. Mobile phone low battery indication.

DISCLAIMER

Tripper unit display may look dull during sun overhead conditions this is normal and due to impact of direct sunlight on the unit customers to refer during other riding conditions.

OPERATION OF CONTROLS - TRIPPER (If fitted)

1. Primary direction or next turn: Indicates the next turn to be taken along with the distance.
2. Distance to next turn: Shows the distance to next turn.
3. Secondary direction or next to next turn: Indicates the next turn to be taken after the primary direction, will be shown only when primary turn is less than 100 m if there is no turn the display will be blank in this region.
4. Distance to destination or ETA: Shows the total distance to destination or Estimated Time of Arrival (based on user selection from RE Mobile app).

Smartphones compatible version to use RE Mobile app:

1. Compatible with Android and iOS.
2. Android support: Current version -
3. iOS support: Current version
4. Connectivity control only through RE Mobile app.

OPERATION OF CONTROLS - TRIPPER (If fitted)

TRIPPER - DISPLAY FLOW SEQUENCE

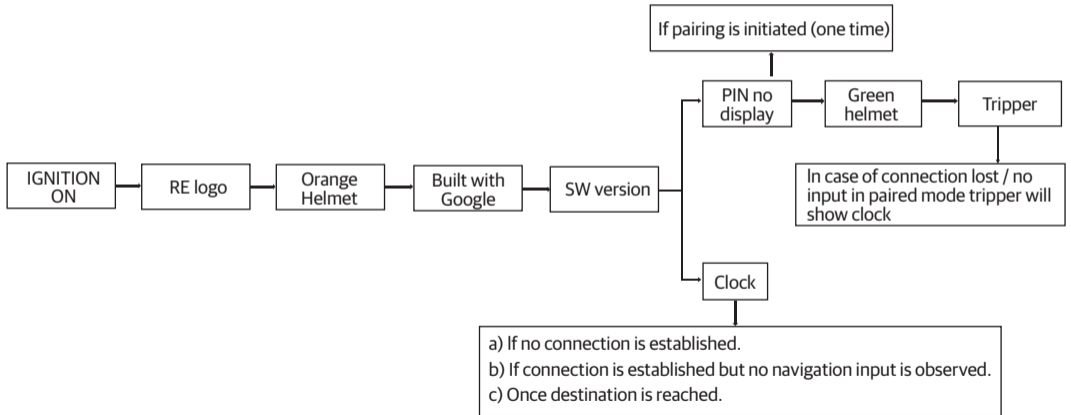

OPERATION OF CONTROIS-TRIPPER (If fitted)

NOTE

1. After every ignition "ON" cycle tripper will be in discoverable mode for 120 sec.
2. Incase there is no connection established within 120 sec display will enter into clock mode to re-initiate connection ignition "OFF-ON" cycle to be repeated.
3. During navigation mode if there is no input from smartphone for 5 sec bluetooth connection will be terminated to avoid power draw and will display clock.
4. Bluetooth connection can be terminated by end user also by closing the mobile application.
5. For first time pairing user needs to enter the secured pin shown on tripper through RE Mobile app to setup the device, after that auto-pairing will happen if same device is connected.
6. Everytime the tripper is paired the clock time will sync with mobile time after which it will continue to run with internal clock even in case of disconnection, there will be time difference between time shown on instrument cluster and tripper - customer needs to update cluster clock inline with time shown on tripper as and when required as mentioned in push button management of cluster.
7. Do not apply or use gasoline/petrol related fluids for cleaning or wiping on instrument cluster or tripper as it will result in permanent damage to the same.

OPERATION OF CONTROLS-TRIPPER (If fitted)

CAUTION

1. Ensure ignition is "ON" and display is in powered while establishing connection.
2. Ensure first time pairing is done in isolated environment to avoid cross connections (one time).
3. Day and night mode is user selectable only, will not change over automatically to be selected during night driving to avoid rider distraction.
4. Bluetooth connection can be established only through RE Mobile app.
5. Ensure bluetooth and location settings are turned always "ON" before usage.
6. Disable battery optimisation settings/low battery cutoff setting of smartphone for navigation to work in low battery mode.
7. RE Mobile app works only with android (Current version -2) and iOS (Current Version -1) versions, for other lower versions performance lag can be expected.
8. Tripper bluetooth version is V4.2.
9. Tripper time display may have a mismatch with actual time displayed in mobile device once the bluetooth connectivity is lost.
10. RE Mobile app works with bluetooth version 4.2 and N+ 1.0, for other lower versions performance lag can be expected.
11. Check for network signal strength in case of navigation lag.
12. Check for data speed in case of navigation lag, navigation system performance is better in 4G band compared to other lower versions.
13. Calibrate mobile phones frequently for more GPS accuracy & location accuracy is dependent on.

WARNING INDICATIONS & SAFETY SYSTEMS

1. ENGINE MALFUNCTION INDICATOR LAMP

A Malfunctioning Indicator Lamp(MIL) is provided in the small meter.

When both the Ignition & Engine kill switch is "ON" and after vehicle is started, the MIL will glow for few seconds and switch "OFF", this indicates that all the functions of Electronic fuel injection (EFI) system is functioning normally.

In the event of any malfunction in the EFI System the MIL will glow continuously. It is recommended to take the motorcycle to a nearest Royal Enfield Authorized service station for a detailed inspection and correction of the EFI system.

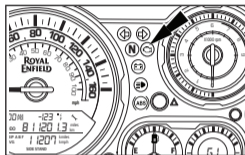

2. Anti-Lock Braking System (ABS)

Anti-Lock Braking System(ABS) will help prevent the brakes from locking the wheels, during sudden application of the brakes at high speeds. This will help the rider to have better traction and control over the motorcycle and prevent the motorcycle from skidding which can cause a accident.

In the event of sudden and hard application of the brakes by the rider, the sensors in the braking system will signal the ABS moderator to momentarily and continuously reduce the hydraulic pressure and thereby prevent the brakes from locking the wheels while reducing the speed of the vehicle. This will help the rider to control the motorcycle.

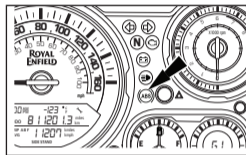

WARNING INDICATIONS & SAFETY SYSTEMS

An ABS indicator lamp is provided in the console (as shown in adjacent image) to warn the rider in the event of any malfunction of the ABS.

When the ignition and kill switch are switched "ON", the ABS sign light up and remain "ON" till the motorcycle attains a speed of 5 kmph (3 mph) and switch "OFF". This indicates the ABS is working properly. In the event the lamp does not switch "OFF" and remains continuously "ON" at higher speeds, it is recommended not to drive the motorcycle and get the brake system inspected and corrected through a nearest authorized Royal Enfield Distributor. Failure to do so can result in a serious injuries and loss of life.

CAUTION (ABS)

1. ABS is a safety feature to help prevent locking of wheels during sudden application of brakes. It is by no means a substitute for good riding practices and anticipatory braking.
2. Please ride carefully and apply brakes cautiously especially while cornering. ABS cannot estimate the "weight shifts" and momentum of the motorcycle while negotiating a corner and therefore prevent skidding due to loss of traction.
3. Please anticipate the stopping distance required for the speed of travel and apply brakes well in advance so as to bring the motorcycle to a safe stop.
4. Please apply both brakes to stop- front brake momentarily earlier followed by rear brake. To have better traction and control of the motorcycle.
5. Always ensure that you ride well within the legal speed limits.
6. Failure to adhere to the above can cause an accident resulting in serious injuries and loss of life.
7. The control function causes a slight pulsing of the hand and foot brake levers.

WARNING INDICATIONS & SAFETY SYSTEMS

DO'S AND DON'TS : (ABS)

DO'S	DONT'S
<ul style="list-style-type: none">While starting the engine do check the ABS indicator comes "ON" and switches "OFF" when the vehicle speed exceeds 5 kmph (3.1 mph).	<ul style="list-style-type: none">Do not release the brake lever/pedal when pulsations are felt during hard application of the brakes in an emergency situation. The pulsations only indicate that the ABS is activated.
<ul style="list-style-type: none">Please check the brake fluid at "MAX" level in the front and rear brake master cylinders and there is no leak in the brakes systems.	
<ul style="list-style-type: none">Apply both the brakes simultaneously for better efficiency while braking.	<ul style="list-style-type: none">Do not apply only the front or rear brakes it can lead to inefficient braking.
<ul style="list-style-type: none">In the event of the ABS indicator remaining continuously "ON" please take the motorcycle to a nearest authorized Royal Enfield service station to inspect the brakes system control of the vehicle.	
<ul style="list-style-type: none">ABS switch need to activate only on vehicle static condition.	<ul style="list-style-type: none">Don't try to activate switchable ABS on vehicle running condition.

PRE - OPERATIONAL CHECKS

1. Adequate fuel in fuel tank for the journey planned.
2. Tyres inflated to correct pressure.
3. No side wall cracks cuts or abrasions in the front and rear tyres.
4. Rear chain for proper tension and sufficiently lubricated.
5. Engine oil level.
6. Control cables inner not damaged, frayed or broken. Clutch and accelerator controls working smoothly.
7. Front and rear brake efficiency and free play in front and rear brake levers.
8. Hydraulic oil level correct in both front and rear master cylinders.
9. Free movement of handle bar to left and right sides.
10. All electrical controls horn working correctly
11. Head lamp, tail lamps, brake lamps and indicator lamps working correctly.
12. Front and rear wheel axle nuts tightened properly to torque.
13. Front and rear wheel spokes having proper tightness. no loose or broken spokes.
14. All fasteners are tight to required torque.
15. Engine idling correctly and smooth.
16. No abnormal noise/ leak from engine.



WARNING

For your personal welfare and safety, these preoperational checks should be performed periodically. Failure to do so will affect safe operation, damage your motorcycle and could result in an accident causing serious injury.

RUNNING IN PERIOD

The Himalayan Motorcycle is capable of consistent high speeds. However as with any new motorcycle a "Running-in period" procedure is essential to help in proper "Bedding-In" of the various moving parts in your motorcycle and to achieve optimum performance subsequently.

1. During the first 2,000 km (1243 miles) of run, do not exceed the speed limits as shown in the table below.
2. Do not exceed maximum specified pay load.
3. Warm up the engine for a few minutes at idling speed to allow engine oil to lubricate all the moving parts in the engine before riding the motorcycle.
4. Avoid full throttle operation and do not ride at constant throttle continuously. Vary the speed by 10% while riding.
5. Avoid sudden accelerations and racing starts.
6. Avoid prolonged full-throttle operation. Vary speed occasionally.

Gear \ Motorcycle Speed	First 500 km (mph)	501 - 2,000 km (mph)
1	9.3 mph	12.4 mph
2	15.5 mph	18.6 mph
3	18.6 mph	24.8 mph
4	27.9 mph	34.1 mph
5	37.2 mph	49.7 mph

STARTING

Ensure gear is in neutral position and the neutral Indicator "N" is glowing in the instrument cluster. To shift into neutral, move the motorcycle back and forth gently, while simultaneously shifting the gear.

CAUTION

Do not attempt to shift gears when engine is "OFF" and rear wheel is stationary as it will cause damage to gear shift mechanism. Please move motorcycle back and forth while simultaneously shifting gears.

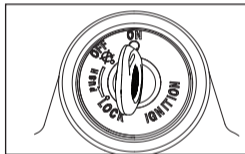

1. Switch "ON" ignition and the kill switch to "RUN" position.
2. Depress clutch lever fully.
3. Press starter button and hold till engine starts.

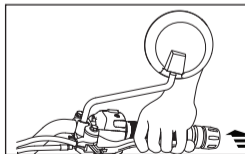

CAUTION

In case engine does not start, do not keep starter button pressed continuously as it will drain the battery. Release button and restart after a few minutes to allow battery to recoup.

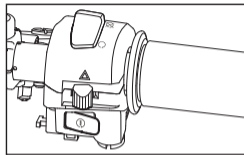

CAUTION

Never accelerate the engine immediately after a cold start. The engine should be allowed to run slowly for 15 sec to 30 sec. This will allow the engine to warm up and let oil reach all surfaces needing lubrication. Failure to adhere in damage to the engine.

NOTE

1. It is recommended to switch off the engine when the engine is in idling condition for long time.
2. It is recommended not to accelerate by giving excessive throttle for more than 5 min when the engine is in idle condition, which will cause damage to the engine internal parts and exhaust system as well.

GEAR SHIFTING, RIDING & STOPPING

1. Warm up engine for 2 min - until idling is consistent.

GEAR SHIFT PATTERN

1-N-2-3-4-5

2. Press clutch lever towards the hand grip.
3. Press gear pedal with toe to engage 1st gear.

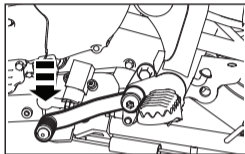

4. Gently open throttle and release clutch simultaneously. If clutch is released suddenly, the engine will stall and cause a jerky start.

CAUTION

The clutch must be fully disengaged before attempting a gear shift. Failure to fully disengage the clutch will cause a jerky start or stalling the engine besides causing damage to transmission parts.

5. Lift gear lever with toe to engage 2nd and subsequent gears.

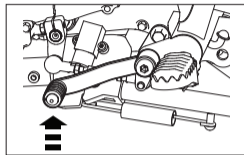

NOTE

1. Always start the engine with gear in neutral position.
2. Always move the motorcycle in 1st gear position only.
3. The motorcycle may begin to slow down and show lack of power while climbing steep hills. In that case, you should shift to a lower gear so that engine will be operating in normal power range which will prevent the motorcycle from losing momentum. The engine may be used for braking by shifting to a lower gear while riding down to steep hill.

PARKING

PARKING MOTORCYCLE ON SIDE STAND

1. Select a firm, flat surface.
2. Extend side stand. Tilt the motorcycle to the left, till it is supported firmly.

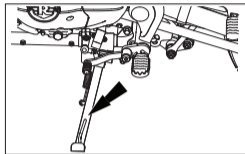

CAUTION

When side stand is in "ON" position.

- a. Engine will start if vehicle is in neutral, but will cut-off (ignition and fuel) when gear is engaged.
- b. Engine will not start if gear is engaged already.



WARNING

1. Ensure side stand is retracted fully before riding the motorcycle.
2. Please exercise extreme care while parking and ensure it is parked firmly to avoid the motorcycle from falling over and causing injury to you or to others and damage to the motorcycle parts.
3. Do not ride motorcycle with the side stand extended. Doing so can cause the side stand to touch the ground while cornering and result in instability & loss of control on the motorcycle leading to a potential accident result in serious injury to both sides and other road users besides causing severe damage to the motorcycle.

NOTE

The side stand is only designed for the weight of the motorcycle. Do not sit on the motorcycle when it is resting on the side stand. The side stand or frame will become damaged and the motorcycle will fall over.

TOOLS KIT

The tools kit is strapped underneath the pillion seat.

S.No	Tool Description	Purpose	Qty
1	Allen key 4mm	To remove side panels LH & RH	1
2	Allen key 6mm	To loosen / tighten pinch bolt on fork end	1
3	Tool spark plug	To loosen / tighten spark plug	1
4	Screw driver	To loosen / tighten screws of housing	1
5	Extension tube	Additional leverage for loosening tightening wheel axle nuts	1
6	Combination spanner open end 17 * 13 mm	To loosen/ tighten hex nuts	1
7	Combination Ring spanner 24 * 14 mm	To loosen / tighten wheel mm axle nuts	1
8	D.E. spanner 10 * 12 mm	To loosen/ tighten hex nuts	1
9	Tool wallet	For storing tools	1

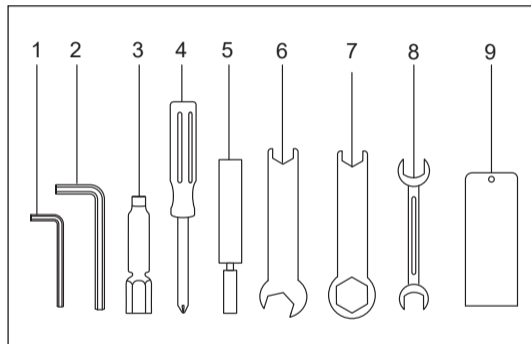

MINOR MAINTENANCE TIPS

The following simple maintenance activities will help in maintaining your motorcycle. However if you are inexperienced or feel it is best done by an experienced person, we recommend you to get in touch with a Royal Enfield Authorised Dealer/ Service Centre.

HAND LEVER PIVOTS

Wipe the area free of dirt/ grease. Apply a few drops of oil on the pivots.

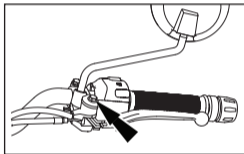

SIDE STAND PIVOTS

Apply a few drops of oil on the pivots after cleaning the area of dirt.

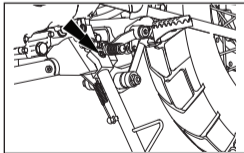

PERIODICAL MAINTENANCE

Lubricate the center stand pivot periodically for smoother operation of center stand.

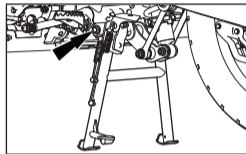

DRIVE CHAIN

Clean the drive chain carefully. Apply chain lubricant while simultaneously rotating the rear wheel. Wipe off the excess lubricant.

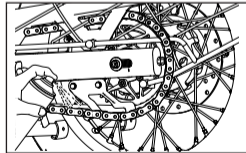

MINOR MAINTENANCE TIPS

OIL LEVEL INSPECTION

1. Place motorcycle on its center stand on a firm surface.
2. Warm up engine for a few minutes & switch off before checking oil level.
3. The level is correct if the oil level is in the middle of the oil level window.
4. Top up only with recommended engine oil.

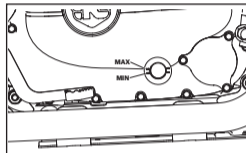

SPARK PLUG

CLEANING AND ADJUSTING PLUG GAP

1. Remove the spark plug cap from the spark plug.
2. Remove spark plug using the plug spanner and tommy bar.
3. Clean the insulator tip and electrodes of the plug carefully.
4. Clean & adjust electrode gap every 500 km if required and replace every 15,000 km.
5. Refit the spark plug on the cylinder head.
6. Refit the spark plug cap on the spark plug.
7. Make sure the spark plug, spark plug cap and HT cable are proper fitment.

CAUTION

Using non-recommended/in-correct oils, can cause serious damage to the moving parts, affect performance of the motorcycle and void the warranty.

MINOR MAINTENANCE TIPS

BRAKE FLUID

1. Check fluid level is between "MIN & MAX".
2. Top up with DOT 4, if required.
3. Do not overfill.
4. Do not mix DOT 4 with other brake fluids.

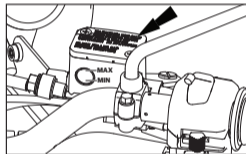

FRONT BRAKE

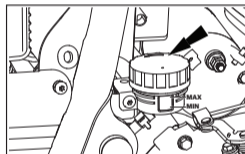

REAR BRAKE

CAUTION

Brake fluid is highly corrosive and can cause damage to painted parts. Please ensure brake fluid does not spill on any part of the motorcycle. In the event of a spill, please clean the area immediately with a soft cloth (preferably a wet cloth) to avoid damage.

INSPECTION OF TYRES AND RIMS

1. Periodically inspect:
 - Rims for spokes breakage wheel rim and run-out.
 - Tyres for proper seating of the beading on the rims.
2. Check and remove stone, splinters, nails or other sharp particles embedded in the tyre.
3. Replace tyres if
 - Side wall cracks, cuts or damages, uneven lugs wear etc.
 - Tyre lugs work out upto the "wear indicator" symbol on the side wall.
4. Use only recommended tyres & tubes, inflated to correct air pressure.

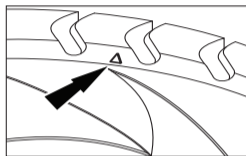

	Front	Rear
Solo	1.75 kg/cm ² (25 psi)	2.25 kg/cm ² (32 psi)
With Pillion	1.89 kg/cm ² (27 psi)	2.39 kg/cm ² (34 psi)

MINOR MAINTENANCE TIPS

WARNING

Dismantling and reassembly of the wheel should be done only by an experienced technician.

Failure to do so will cause loss of control on the motorcycle leading to a potential accident, resulting in serious injury to both rider and other road users, besides causing severe damage to the motorcycle.

FRONT WHEEL REMOVAL

1. Support front end of engine suitably such that the front wheel is off the ground.
2. Loosen pinch bolt on right fork end with 6 mm allen key.
3. Hold spindle on right side and remove spindle nut and washer from left side.
4. Support wheel and pull out spindle from right side.

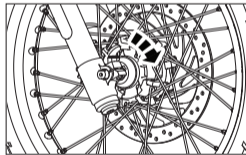

5. Remove the wheel along with RH side spacer & disc side spacer. OR (Follow below procedure if vehicle have a wheel speed sensor assembly).
6. Remove wheel along with wheel speed sensor and spacer.

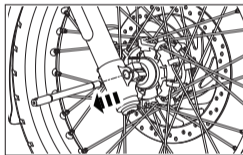
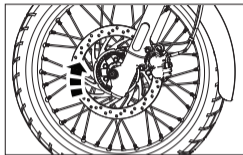

CAUTION

Do not press the brake lever when wheel is removed as this will result in the brake pads coming out too far from the brake caliper.

1. Place a suitable spacer of 4 mm thickness, between the brake pads to avoid accidental compression of the brake lever.

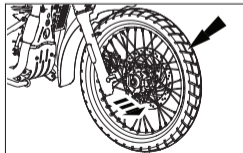

MINOR MAINTENANCE TIPS

FRONT WHEEL REASSEMBLY

1. Remove the spacer placed between the brake pads.
2. Locate wheel speed sensor lugs on the hub slot carefully.
3. Position the wheel along with RH side Spacer & Disc side spacer on left side between the front fork legs, ensuring the brake disc is located between the brake pads.

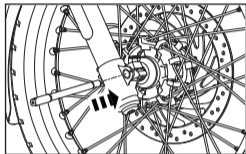

OR

(Follow below procedure if vehicle have a wheel speed sensor assembly).

Position wheel along with wheel speed sensor and spacer on left side between the front fork legs, ensuring the brake disc is located between the brake pads.

4. Insert wheel spindle from right fork end.

5. Ensure the position of RH side Spacer & Disc side spacer aligned properly.

OR

(Follow below procedure if vehicle have a wheel speed sensor assembly).

Position wheel speed sensor such that it is parallel to ground.

6. Holds spindle on right side, locate washer and nut on spindle on left side and tighten firmly.
7. Tighten pinch bolt on right fork end.
8. Rotate wheel and check for smooth rotation.
9. Press brake lever and check front brake for efficiency.

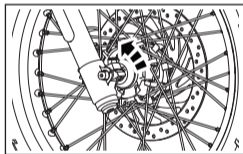
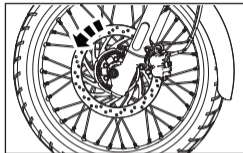

MINOR MAINTENANCE TIPS

REAR WHEEL REMOVAL

1. Ensure the motorcycle is on a firm, flat surface and the rear wheel is off the ground.

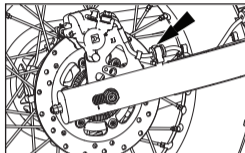

2. Gently remove the brake hose along with its rubber grommets from the locating clips on the swing arm.

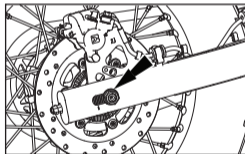

3. Loosen rear axle nut on the right side and remove along with washer.
4. Pull out the wheel axle from the left side, taking care not to drop the wheel spacers.

5. Remove the brake caliper assembly from the slot in the swing arm along with ABS wheel speed sensor and support it suitably to avoid damage to the brake hose and ABS wheel speed sensor.

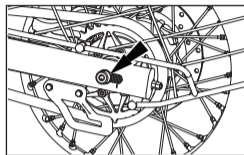

6. Slide out the rear wheel from the swing arm, taking care not to drop the spacers on the wheel hub.

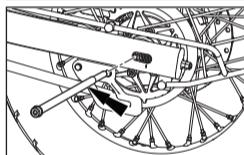

CAUTION

Do not press the brake lever when wheel is removed as this will result in the brake pads coming out too far from the brake caliper.

1. Place a suitable spacer of 4 mm thickness, between the brake pads to avoid pads compression in the event the brake pedal is pressed accidentally.

MINOR MAINTENANCE TIPS

REAR WHEEL REASSEMBLY

1. Ensure the cush rubbers are in place in the wheel hub.
2. Insert the wheel assembly between the swing arms and position the cush rubbers on the rear sprocket lugs correctly.
3. Remove the spacer between the brake pads and locate the caliper such that the brake disc is between the brake pads.
4. Locate the caliper bracket slot on the lug in the swingarm.
5. Position the respective spacers on the left and right side of the wheel hub.
6. Ensure the axle mounting hole in the swing arm, wheel hub and caliper bracket are aligned.

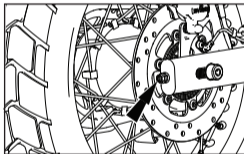
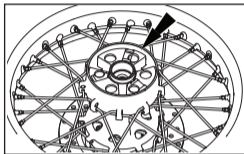

7. Insert the wheel axle from the left side of the swing arm and gently tap it in.

CAUTION

1. Do not force the spindle through as it will cause damage to the threaded end.
2. Ensure correct chain tension and rear wheel alignment with front wheel by adjusting the adjusters on both left and right side of swing arm.
3. Assemble washer and wheel axle nut on right side and tighten to correct torque.
4. Fix the brake hose pipe in swing arm clips properly.

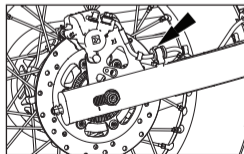
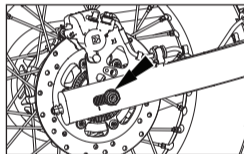
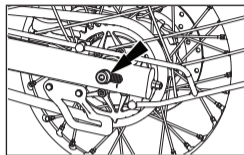

MINOR MAINTENANCE TIPS

CAUTION

1. Please ensure the brake hose is correctly positioned on the clips, without any twist, sharp kinks or damage as it will seriously affect the performance of the rear brake.
2. Check rear brake for effectiveness and correct functioning before using the motorcycle.

DRIVE CHAIN TENSION (FREE PLAY 20-30 mm)

1. Measure the drive chain free play on the top run of the chain.
2. The recommended free play is 20 to 30 mm.

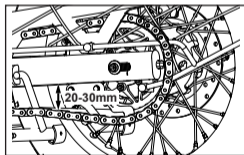

To adjust the chain tension and free play.

3. Loosen rear wheel spindle nut.
4. Loosen lock nuts of the chain adjuster on both ends of the swing arm.
5. Tighten/loosen the adjuster nut on left swing arm end, to reduce/increase chain tension.
6. Ensure the ground is level & firm and place the motorcycle in its center stand.
7. Rotate wheel slowly and check chain free play at the top run to be between 20- 30 mm.

MINOR MAINTENANCE TIPS

WARNING

Please follow instructions as per periodical maintenance.

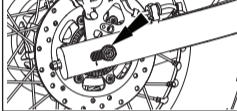
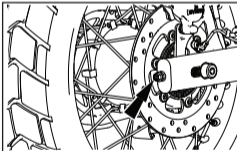
1. Tighten/loosen adjuster nut on right side to align the front and rear wheels and also to align the reference marks on both left and right side of the swing arm.
2. Tighten the lock nuts against the adjuster nuts, taking care not to disturb the adjuster nut settings.
3. Tighten rear wheel spindle nut to a specified torque.

WARNING

1. Chain slackness beyond 30 mm will lead to chain slippage.
2. Maintain drive chain slackness within the specified limits at every 1,000 km (621 mile) interval.
3. Please check the front and rear wheels are correctly aligned, after the chain adjustment.
4. If the engine/rear sprocket are worn, replace the engine/rear sprocket & rear chain as a kit.

MINOR MAINTENANCE TIPS

ADJUSTMENTS - CLUTCH LEVER FREE PLAY

Clutch Lever (free play 2 - 3 mm)

1. Loosen the cable outer lock nut(a).
2. Turn the nut (b) clockwise to reduce the play or anticlockwise to increase the free play.
3. Check free play 2 to 3 mm at clutch lever pivot on handle bar end.
4. Tighten lock nut (a) after adjustment is done.

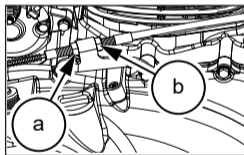
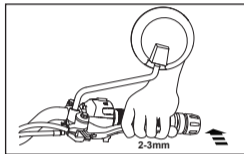

ADJUSTMENTS - REAR BREAK PEDAL FREE PLAY

Rear brake pedal free play 7 to 11 mm.

1. Loosen the lock nut in master cylinder push rod assembly.
2. Rotate the master cylinder push rod anti clockwise to reduce the rear brake pedal free play.
3. Rotate the master cylinder push rod clockwise to increase the rear brake pedal free play.
4. After adjustment tighten the lock nut in master cylinder push rod assembly.

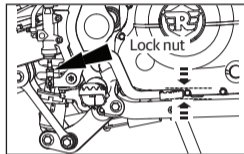

MINOR MAINTENANCE TIPS

BRAKE PAD WEAR

- Brake pad wear depends upon the severity of usage, the type of riding and road condition.

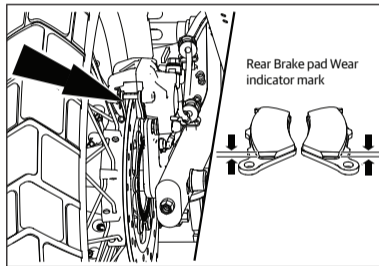
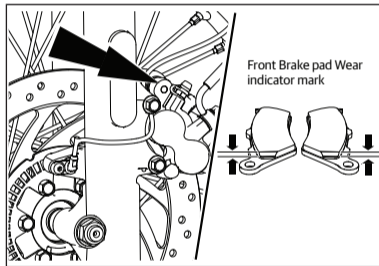

Check the wear indicator mark on each pad. If either pad is worn to the wear indicator mark. Replace both pads as set. Visit royal enfield dealer for this service.

MINOR MAINTENANCE TIPS

BATTERY & MAINTENANCE

1. The motorcycle is provided with 12 V - 8Ah MF battery.
2. The battery must be periodically checked for corrosion free terminals.

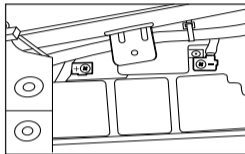

REMOVAL OF BATTERY FROM THE MOTORCYCLE

1. Remove the side panel on the right side by unscrewing the hex socket button head screws.
2. Ensure motorcycle is parked on its center stand, in a well ventilated area.

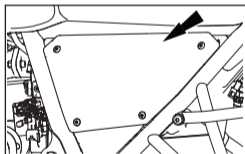

3. Ensure the ignition switch and engine stop switch are in "OFF" position.
4. Disconnect the Harness connectors around the battery located area.
5. Unlock (turn the key clockwise) and remove the pillion seat.
6. Remove front seat.
7. Remove the Battery carrier bracket by loosening the hex bolt.
8. Disconnect both the Battery terminals wires (negative first and positive next respectively).
9. Take out the battery.

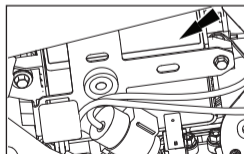
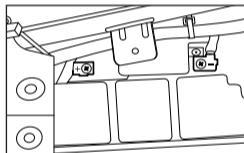
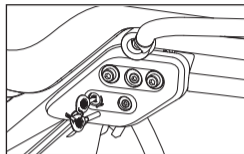

MINOR MAINTENANCE TIPS

WARNING

Always disconnect the black negative (-) battery cable first and then the red positive (+) cable while removing the battery connections.

REASSEMBLY OF BATTERY ON MOTORCYCLE

1. Position the battery in the battery carrier such that the terminals are facing inside.
2. Ensure ignition switch is in "OFF" condition.
3. Connect the red wire to the positive terminal of the battery first.
4. Next, connect the black wire to the negative terminal of the battery.
5. Smear the terminals with petroleum jelly. (Do not use grease in the battery terminals).

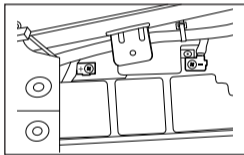

6. Place the terminal boot/cap properly.
7. Refit the battery bracket.
8. Reconnect the harness connector to the respective couplers on the battery located area.
9. Refit the right side panel.
10. Reassemble rider seat & Pillion seat.

NOTE

1. Clean the wire terminals free of corrosion and keep the terminals coated with petroleum jelly.
2. It is not necessary to check the battery electrolyte level or add distilled water as the battery is a maintenance free (Sealed type).
3. Your battery is a maintenance free type and can be permanently damaged if the cap strip is removed.

MINOR MAINTENANCE TIPS

CAUTION

Keep the +ve and -ve cables firmly connected to the respective battery terminals. Failure to do so will result in damage to the motorcycle electrical system.

WARNING

Always disconnect the negative(-) battery cable first and then the positive (+) cable while removing the battery connections. If the positive (+ve) battery cable should contact terminal with the negative (-ve) cable installed, the resulting sparks will cause a battery explosion which could result in serious injury.

WARNING

Battery terminals and internals contain lead and lead components, known to cause cancer and birth defects or other reproductive harm. Always wear approved protective face shield, rubberized gloves and protective clothing when working with batteries. Keep batteries and acid out of reach of children.

NOTE

Usage of frequency for motorcycle is very important for battery to be in good performance condition. If the motorcycle is being used very rarely or sparingly and the terminals are not disconnected the battery is bound to lose its charge and result in a dead battery.

MINOR MAINTENANCE TIPS

CHANGING ELECTRICAL COMPONENTS

HEADLAMP BULB DISMANTLING

1. Remove the 2 screws holding the head lamp rim to the housing.
2. Gently pull out the head lamp rim along with reflector assembly.
3. Disconnect head lamp coupler.
4. Remove the protective rubber cap over the bulb.

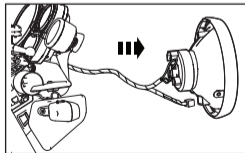
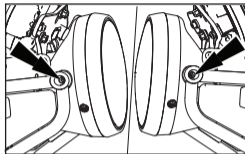

5. Gently press the bulb holding clip and release it from the slot in the reflector.
6. Remove the bulb from the reflector.

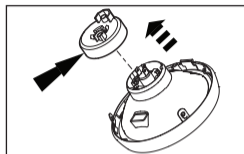

NOTE

1. Never touch the bulb with your fingers. Finger prints will etch the glass and decrease bulb life.
2. Always hold the bulb with clean dry cloth during handling.
3. Do not disturb the vent cap provided in the inner body mould.

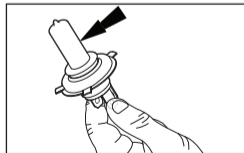
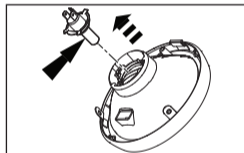

MINOR MAINTENANCE TIPS

HEADLAMP BULB REPLACEMENT

1. Locate the 3 lugs in the bulb correctly in the reflector.

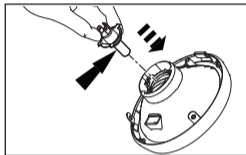

2. Locate the bulb holding clip over the bulb and lock it in the slot in the reflector.

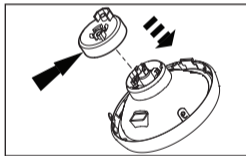

3. Put the protective rubber cap over the bulb correctly such that the vent pipe is facing downwards.

4. Connect head lamp coupler on the bulb terminals correctly.

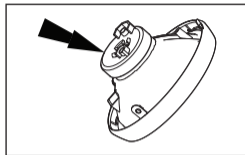

5. Locate the head lamp rim in the housing correctly such that it locks in place and the 2 mounting holes of the rim are aligned with the holes in the housing.

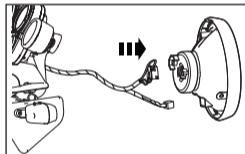

6. Assemble the 2 screws and tighten firmly.

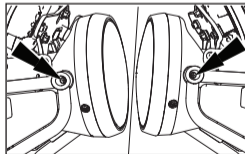

MINOR MAINTENANCE TIPS

TAIL LAMP & LICENSE PLATE ILLUMINATOR

1. The tail lamp & license plate illuminator has a LED lighting system. In the event of failure, the entire tail lamp & license plate illuminator assembly should be replaced.
2. Contact an Authorised Royal Enfield Dealer/Service Centre to replace the same.

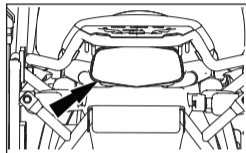

TRAFFICATOR BULB REPLACEMENT

1. Remove the screw from the trafficator housing back side.
2. Remove outer lens.
3. Remove the fused bulb by pushing and turning in anticlockwise direction.

4. Position the new bulb inside the holder, ensuring that the pins in the bulb, match with slots in the holder.
5. Push the bulb and turn clockwise direction to lock the bulb in the holder.
6. Refit the trafficator cover with reflector and tighten the screw.

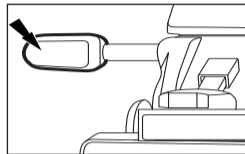

NOTE

Do not over tighten the screw. Make sure the Ignition switch is in "OFF" position when replacing the bulbs, fuses and electrical parts.

MINOR MAINTENANCE TIPS

FUSE

1. Remove the RH side panel.
2. Replace the required fuse with the spare fuse available in the fuse carrier.
3. The blade fuses are located in the carrier.

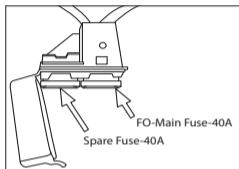

NOTE

Please ensure to replace a spare fuse in the holder at the earliest opportunity.

FUSE & CARRIER

1. The fuse carrier is located under the rider seat.
2. Remove the pillion seat and rider seat.
3. Open the fuse carrier lid & replace fuse as indicated inside the lid.
4. Replace the required fuse with the spare fuse available in the fuse carrier.

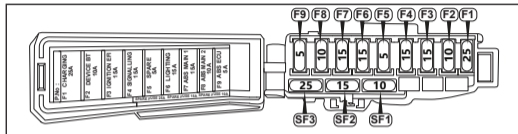

NOTE

F2	Device Bt + Fuse	10 A	EMS ECU, Instrument Cluster, Tripper.
F3	Ignition Fuse (EFI)	15 A	Relay Coil, EMS ECU, Ignition Coil, Fuel pump, Injector, O2 Sensor, E purge and Diagnostic tool.
F4	Signalling Fuse	15 A	Instrument Cluster, Tripper, Gear Position Sensor, Flasher, Brake Switch and Horn.
F6	Lighting Fuse	15 A	Headlamp Low & High Beam, Front Position Lamp, Rear Position Lamp & License Plate Illuminator.

Please ensure to replace a spare fuse in the holder at the earliest opportunity.

MINOR MAINTENANCE TIPS

BLADE FUSE USAGE LIST

ID No.	Color	Rating	Function
F1	WHT	25 A	CHARGING FUSE
F2	RED	10 A	DEVICE Bt+ FUSE
F3	BLU	15 A	IGNITION FUSE (EFI)
F4	BLU	15 A	SIGNALLING FUSE
F5	YEL	5 A	SPARE FUSE
F6	BLU	15 A	LIGHTING FUSE

ID No.	Color	Rating	Function
F7	BLU	15 A	ABS MAIN 1
F8	RED	10 A	ABS MAIN 2
F9	YEL	5 A	ABS IGNITION
SF1	RED	10 A	SPARE FUSE
SF2	BLU	15 A	SPARE FUSE
SF3	WHT	25 A	SPARE FUSE

WARNING

Please get the electrical system of your Motorcycle checked thoroughly and get the faults corrected immediately after experiencing any fuse failure. Not doing this can result in to repeated fuse failures.

Usage of fuses other than specified rating will damage the complete electrical system.

MINOR MAINTENANCE TIPS

WINDSHIELD CLEANING

Wipe the windshield with a soft cloth. Do not wipe vigorously as it will cause scratches on the windshield.

Use a mild detergent and lukewarm water to remove any hard coating, insect hits etc. from the windshield.

Rinse well with water and use a soft dry and lint free cloth to wipe off the water.

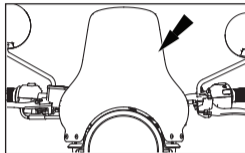

CAUTION

1. Use of any hard cleaning substances such as stain removers, water repellent compounds, petroleum products, solvents and alcohol based material will seriously affect the windshield transparency.

2. Scratches, cloudiness, cuts and abrasions on the windshield cannot be polished or removed. The windshield must only be replaced if damaged.



WARNING

Never attempt to clean the windshield while riding. Failure to do so may cause loss of control on the motorcycle, leading to a potential accident, resulting in serious injury to both rider and other road users, besides causing severe damage to the motorcycle.

SHOCK ABSORBER

SPRING PRELOAD & SHOCK ABSORBER SETTINGS

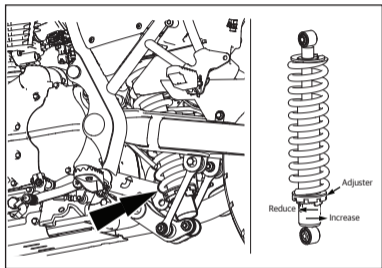

INCREASING THE PRELOAD

To increase spring preload, turn preload adjuster in the clockwise direction.

REDUCING THE PRELOAD

To decrease the spring preload, turn preload adjuster in the anti-clockwise direction.

CAUTION

It is recommended to visit Authorised Dealer for adjusting spring preload and shock absorber settings.

OFF ROADING

AFTER OFF ROADING

It is recommended to check the following after off roading:

TYRE PRESSURE

1. Tyre pressure needs to be optimal for effective riding on surfaced roads.
2. Always check the tyre pressures are correct.

BRAKES

1. Riding on dirty & muddy roads brakes will not be effective immediately because of dirt & moisture on the disc pads.
2. Apply the brakes in good time until the brakes have been cleaned.

RIMS

1. It is recommended to check the rims & wheels for damage after off roading.

SPRING PRELOAD & SHOCK ABSORBER SETTINGS

1. The off road settings of spring & shock absorber settings will impair the motorcycle's handling characteristics on surfaced roads.
2. Remember to correct the spring & shock absorber settings before returning to surfaced roads.

AIR FILTER ELEMENT

1. Cleaning of air filter element is recommended for effective utilisation of air filter element in returning to surfaced roads.
2. Check for any damages or clog in air filter and replace if required.

LONG TRIP PRECAUTIONS

CHECKS PRIOR TO THE COMMENCEMENT OF LONG JOURNEY

1. Service the motorcycle at a Royal Enfield Authorised Dealer/Service centre.
2. Ensure sufficient quantity of petrol in the fuel tank for the journey planned.
3. Check and correct tyre pressure if necessary.

CHECKS AFTER EVERY 1500 km (932 mile) OF RUN

1. Any loose fasteners.
2. Condition of the tyres.
3. Correct oil level in engine.
4. Working of all lights and horn.
5. Proper drive chain tension.

ITEMS TO BE CARRIED

1. Tool kit.
2. First aid kit.
3. Bulbs for headlight, trafficator light, fuse.
4. Accelerator, clutch cables.
5. Rear chain master link lock assembly.
6. Insulation tape.
7. Spark plug, spark plug cap.

WASHING PROCEDURE

PRECAUTIONS

1. Wash motorcycle when the engine is cold.
2. Cover the silencer, tail pipe, horn, control switches, instrument cluster & tripper with suitable plastic bags and tie it firmly to prevent water entry.
3. Remove ignition key and seal key hole using adhesive tape.
4. Brush engine area with a solvent to remove dirt or grease.
5. Use low pressure jet of water to clean.
6. Do not spray water directly on the steering stem area as it will damage the bearings and cause the handle bar movement to become sticky.
7. Never spray water with great force on head lamp, speedometer, flasher lights, front and rear wheel hubs, electrical connections and wires, control cables, cables, sparkplug, battery, ABS ECU, EMS ECU, side mirrors, steering stem etc.
8. Do not apply any corrosive solvent on painted surfaces or rubber parts.
9. Use luke warm water and mild detergent on the painted components to remove dirt, etc.
10. Rinse motorcycle thoroughly with plain water to remove the detergent.
11. If possible, use compressed air and blow off water particles from the hard to reach areas of the motorcycle, electrical connections etc.
12. No direct jet at the edges of decal, electrical parts, coupler joints, silencer tail pipe, radiator lubrication points like steering cone kit, brake pedal, wheel bearings, chain, brake cam & swing arm bushes to be washed in spray mode only (not in jet mode).
13. Once the motorcycle has been ridden in salty conditions or near coastal areas it is recommended to wash your motorcycle with cold water. Please do not use warm water for washing as it will damage the motorcycle due to chemical reaction with the salt.

WASHING PROCEDURE

1. After washing process once the motorcycle is completely dry it is recommended to apply anti corrosion spray on all the metal and chrome plated areas to protect the parts from corrosion.
2. It is recommended not to apply the anti-corrosion spray on the brake discs.

Locations of Stickers :

Front mudguard, rear mudguard and both side panels

NOTE

High pressure water jet should not directly shown on sticker locations.

AFTER WASHING

1. Ensure, the motorcycle is thoroughly dry by wiping with a clean soft lint free absorbent cloth or chamois leather.
2. Remove all plastic bags and adhesive tapes.
3. Lubricate control cables, pivot and rear chain with lube oil.
4. Polish the painted (except Stone Black Colour / Matt paint finish) and plated surfaces using recommended automobile polishing wax.
5. Start the engine and allow to run at an idling speed for a few minutes to warm up engine.
6. Drive the motorcycle slowly, apply both the brakes intermittently to dry up the water in the brake shoes.

STORAGE PRECAUTIONS

In case your motorcycle is not going to be used for a month or more, the following precautions should be taken.

1. Get the motorcycle serviced through a Royal Enfield Authorised Dealer/ Service Centre.
2. Drain fuel tank and fuel line.
3. Spray engine oil inside the fuel tank to prevent rusting.
4. Remove spark plug. Pour in about 25 ml of clean engine oil through spark plug hole. Close the hole and crank engine several times and refit spark plug.
5. Clean rear chain thoroughly and apply a chain lube.
6. Remove battery from the motorcycle. Clean the terminals free of corrosion and apply petroleum jelly to terminals.
7. Store the battery in a cool, dry and well ventilated place.
8. Cover the silencer with plastic bags to prevent moisture entry. Set the motorcycle on its center stand.
9. Apply anti rust solutions on all plated parts. Take care not to apply this solution on rubber or painted parts.
10. Store motorcycle in a clean covered area free of moisture and dust.
11. For re-use after storage, it is preferable to get the motorcycle prepared through a Royal Enfield Authorised Dealer/Service Centre to ensure the motorcycle is restored to its peak operating conditions.
12. If the motorcycle is not used for a month or longer, It is advised to disconnect battery terminals and remove the battery. Before refitting the battery in the motorcycle, check the battery voltage is within specification, if not, recharge it from authorised service workshop/battery dealer.

TROUBLESHOOTING

We have listed below a few basic checks in case your motorcycle is not functioning. If in case the problem is not rectified after these checks, it is necessary to get the motorcycle checked by a Royal Enfield Authorised Dealer/ Service Centre to rectify the problem and to ensure trouble free performance.

Symptom	Observations	Check for/Remedy
Engine does not start	1. Ignition/Engine stop switch is in "OFF" position.	Switch 'ON' ignition/engine stop switch.
	2. Very low/No fuel in the fuel tank.	Fill fuel.
	3. Lights/horn very dim (Horn poor/Low sound).	Weak/Discharged battery, contact Authorised Service Centre.
	4. Electricals not working.	1. Battery completely dead. Replace battery. 2. Fuse blown. Replace appropriate fuse. Note: if fuse blows again, contact Authorised Service Centre.
	5. Engine cranking but not starting.	Spark plug cap/wire disconnected. Reconnect. Check if side stand is on/Side stand switch malfunction. Check if gear is engaged and the side stand is down. If the ambient temperature is low use manual bi-starter.

TROUBLESHOOTING

Symptom	Observations	Check for/Remedy
Engine starts but shuts off immediately	Engine shuts off as soon as throttle is closed.	Idling rpm set too low/Setting disturbed. Contact Authorised Service Centre for resetting the idling rpm. Check if the MIL lamp is glowing; if yes, contact Authorised Service Centre.
Engine misfires & runs erratically/stops.	1. Typically happens after a Refill/Adulterated/Water in Fuel.	Drain out entire fuel and refill with fresh fuel from a reputed filling station.
	2. Motorcycle driven in low gear/High rpm/Crowded places for long time.	Excessive engine temperature. Switch "OFF" engine and allow to cool down. Check if the MIL lamp is glowing; if yes, contact Authorised Service Centre.

TROUBLESHOOTING

Symptom	Observations	Check for/Remedy
Poor pickup	Engine rpm raises disproportionately to motorcycle speed.	Clutch is slipping. Check for sticky clutch/Clutch not having any free play.
	Rear chain excessively loose causing chain to slip on Sprocket.	Adjust rear chain to correct tension. Check if the MIL lamp is glowing; if yes, contact Authorised Service Centre.
ABS (Anti - lock braking system)	ABS lamp continuously "ON".	Take the vehicle to service centre for diagnosis.

ENVIRONMENT CARE

BE AN ENVIRONMENTALLY CONSCIOUS RIDER

You've ridden through some beautiful places on your Royal Enfield. Won't you like to keep them that way? Here are some tips to help you keep those places unspoilt so that others can enjoy them too:

Disposal of end of life - Parts / Vehicle

While your liquid waste like engine oil, coolant and other cleaning solvents need to be regularly replaced, what happens to them? Make sure they are not dumped in the soil or water bodies.

You shall store them in a container and handover to an Govt authorized recycling agent, If any or RE Service Centre.

In the case of battery, tyres, plastic parts, electric or electronic parts and oil filter shall be handed over only to an authorized recycling agent, If any or RE Service Centre.

The cleaning solvents or sprays whichever used for cleaning your bike shall be disposed in an environmentally friendly manner.

In case you want to dispose your vehicle considered as an end of life vehicle, please handover the vehicle only to an authorized / registered vehicle scrapping facility near you or contact local authorities to follow due process.

PERIODICAL MAINTENANCE

The periodical maintenance schedule detailed below is based upon average riding conditions and indicates the intervals at which regular inspections, adjustments, replacements and lubrications must be carried out to help maintain your Himalayan motorcycle meticulously. If in case the motorcycle is used frequently in very dusty environment/ severe climatic conditions/ poor roads/ stagnant water etc., the maintenance will need to be done earlier as will be required.

Contact a nearest Royal Enfield Authorised Dealer/ Service Centre to carry out the periodical maintenance and for any expert advice.

Sl. No.	DESCRIPTION	PERIODICAL MAINTENANCE (Whichever is earlier)											
		0.5	5	10	15	20	25	30	35	40	45	50	
	km (x 1,000)												
	Miles (x 1,000)	0.3	3	6	9	12	15	18	21	24	27	30	
	Months	1.5	6	12	18	24	30	36	42	48	54	60	
1	Engine oil (level check/ replace)	R	I	R	I	R	I	R	I	R	I	R	
		Check level at every 1,000 km or earlier as required											
2	Engine oil filter element	R		R		R		R		R		R	
3	Engine oil strainer on crankcase LH	C		C		C		C		C		C	
4	Inlet/ Exhaust tappet setting	I&A	I&A	I&A	I&A	I&A	I&A	I&A	I&A	I&A	I&A	I&A	I&A

PERIODICAL MAINTENANCE

Sl. No.	DESCRIPTION	PERIODICAL MAINTENANCE (Whichever is earlier)										
		0.5	5	10	15	20	25	30	35	40	45	50
	km (x 1,000)	0.5	5	10	15	20	25	30	35	40	45	50
	Miles (x 1,000)	0.3	3	6	9	12	15	18	21	24	27	30
	Months	1.5	6	12	18	24	30	36	42	48	54	60
5	Rubber hose, inlet manifold	I	I	I	I	I	I	I	I	R	I	I
6	Oil cooler inlet & outlet pipes	I	I	I	I	I	I	I	I	I	I	I
7	Spark plug	C&A	C&A	C&A	R	C&A	C&A	R	C&A	C&A	R	C&A
8	HT leads for crack	I	I	I	I	I	I	I	I	I	I	I
9	Fuel hose & clip	I	I	I	I	I	I	I	I	R	I	I
10	Fuel pump (under tank) mounting	Check for screw tightness in all services										
11	Air filter element	C	C	R	C	R	C	R	C	R	C	R
		Clean/ Replace more frequently if motorcycle always used in dusty/ off Road conditions.										
12	Accelerator cable	I&A	I&A	I&A	I&A	I/A/R	I/A/R	I/A/R	I/A/R	I/A/R	I/A/R	I/A/R

PERIODICAL MAINTENANCE

Sl. No.	DESCRIPTION	PERIODICAL MAINTENANCE (Whichever is earlier)										
		0.5	5	10	15	20	25	30	35	40	45	50
	km(x 1,000)	0.5	5	10	15	20	25	30	35	40	45	50
	Miles (x 1,000)	0.3	3	6	9	12	15	18	21	24	27	30
	Months	1.5	6	12	18	24	30	36	42	48	54	60
13	Rubber hose, Air filter to throttle body	I	I	I	I	I	I	I	I	R	I	I
14	PAV pipes & hose clip	I	I	I	I	I	I	I	I	R	I	I
15	Evaporative emission equipment rubber hoses	I	I	I	I	I	I	I	I	R	I	I
16	Throttle body	Throttle body should be removed from the vehicle and cleaned with a dry microfibre cloth, Usage of throttle body cleaners or any similar solvent or alcohol based liquids for cleaning is strictly prohibited. Throttle body cleaning every 10,000 km (6214 mile) /12 months or earlier as required.										
17	Clutch cable	I&A	I&A	I&A	I&A	I/A/R	I/A/R	I/A/R	I/A/R	I/A/R	I/A/R	I/A/R

PERIODICAL MAINTENANCE

Sl. No.	DESCRIPTION	PERIODICAL MAINTENANCE (Whichever is earlier)										
		0.5	5	10	15	20	25	30	35	40	45	50
	km(x 1,000)	0.5	5	10	15	20	25	30	35	40	45	50
	Miles (x 1,000)	0.3	3	6	9	12	15	18	21	24	27	30
	Months	1.5	6	12	18	24	30	36	42	48	54	60
18	Clutch free play	Adjust every 1,000 km (621 mile) or earlier as required										
19	Clutch no slippage	I	I	I	I	I	I	I	I	I	I	I
20	Steering head bearings#	I & A	Inspect & If required lubricate for every 5000 km (3107 mile) or earlier as required. Replace if necessary									
21	Front fork oil	I	I	I	I	R	I	I	I	R	I	I
22	Rear wheel drive chain#	I & A	Clean, Lubricate & adjust every 1000 km (621 mile) or earlier as required									
23	Battery terminals (apply petroleum jelly)	C	C	C	C	C	C	C	C	C	C	C
24	Earth wire eyelet tightness			I		I		I		I		I
25	Hydraulic brake fluid - front & rear#	I	I	I	I	R	I	I	I	R	I	I

PERIODICAL MAINTENANCE

Sl. No.	DESCRIPTION	PERIODICAL MAINTENANCE (Whichever is earlier)										
		0.5	5	10	15	20	25	30	35	40	45	50
	km (x 1,000)	0.5	5	10	15	20	25	30	35	40	45	50
	Miles (x 1,000)	0.3	3	6	9	12	15	18	21	24	27	30
	Months	1.5	6	12	18	24	30	36	42	48	54	60
26	Hydraulic brake hose & washers - front& rear#											
27	Brake pads - front & rear#											
28	Tyre wear pattern (front & rear)# (1)											
29	Spokes tightness/wheel rim run out front & rear#											
30	Front & Rear wheel bearings for play#						I&R					I&R
31	Swing arm pivot bearings#		Inspect & If required lubricate for every 5000 km (3107 mile) or earlier as required. Replace if necessary									

PERIODICAL MAINTENANCE

Sl. No.	DESCRIPTION	PERIODICAL MAINTENANCE (Whichever is earlier)										
		0.5	5	10	15	20	25	30	35	40	45	50
	km(x 1,000)	0.5	5	10	15	20	25	30	35	40	45	50
	Miles (x 1,000)	0.3	3	6	9	12	15	18	21	24	27	30
	Months	1.5	6	12	18	24	30	36	42	48	54	60
32	Rear suspension linkages#	I	Inspect & If required lubricate for every 5000 km (3107 mile) or earlier as required. Replace if necessary									
33	Rear brake pedal pivot	L	L	L	L	L	L	L	L	L	L	L
34	Rear brake pedal free play	Adjust every 1,000 km (621 mile) or earlier as required										
35	Rear wheel cush rubbers#	I	I	I	I	I&R	I&R	I&R	I&R	I&R	I&R	I&R
36	All mounting fasteners in vehicle for tightness#	I&T	I&T	I&T	I&T	I&T	I&T	I&T	I&T	I&T	I&T	I&T
37	Hand levers, center stand, side stand, rider & pillion foot rest pivots & gear shift levers #	Lubricate every 1,000 km (621 mile) or earlier as required										
38	Cam chain / chain pads / auto chain tensioner	I	I	I	I	I	I	I	I	I	I	I&R

PERIODICAL MAINTENANCE

Sl. No.	DESCRIPTION	PERIODICAL MAINTENANCE (Whichever is earlier)										
		0.5	5	10	15	20	25	30	35	40	45	50
	km(x 1,000)	0.5	5	10	15	20	25	30	35	40	45	50
	Miles (x 1,000)	0.3	3	6	9	12	15	18	21	24	27	30
	Months	1.5	6	12	18	24	30	36	42	48	54	60
39	Starter motor & starter relay connections	I	I	I	I	I	I	I	I	I	I	I
40	Side stand switch operation	I	I	I	I	I	I	I	I	I	I	I

A:Adjust

C: Clean

I : Inspect (Clean, Adjust, Lubricate or Replace if necessary)

T : Re-tighten (2)

L: Lubricate

R: Replace

Service more frequently when ridden in unusually wet or dusty areas.

Service more frequently when riding in rain or at full throttle.

(1) Tyre to be replaced if the tyre wear identification mark reached (2) To be done at authorised Royal Enfield Dealer/ Service Center.

For maintenance after 50,000 km / 31068 mi, , please repeat same frequency specified above, in consultation with a Royal Enfield Authorised Dealer / Service Center.

WARRANTY TERMS & CONDITIONS

Royal Enfield Motorcycles are manufactured by following best quality practices in respect of the material and workmanship.

Royal Enfield (RE) warrants its motorcycle to be free from manufacturing and material defect under normal use subject to following conditions.

1. RE will replace or repair defective part(s) at their Dealerships and Authorised Service Centre free of charge within a period of 36 months from the date of sale. whichever is earlier.
2. In order to avail warranty benefits by second or subsequent owner the second/subsequent owner should inform the nearest Royal Enfield Service Centre about the purchase of the bike and shall fill in the requisite details in the form as requested by Royal Enfield.
3. The warranty shall be applicable only if all the services are availed in the respective period/kilometer ranges as per the schedule in the owner's manual from RE Authorised Dealer/Service Centre.
4. During the warranty period. RE's obligations shall be limited to repairing/replacing part(s) of the motorcycle for free only if the part(s). On examination is deemed to have a manufacturing defect. Defective part(s) which have been replaced will become the sole property of RE.
5. Consumables like oil, oil filter, fuel etc. used during warranty repair/replacement are not covered and chargeable to the customer.

WARRANTY TERMS & CONDITIONS

6. Claims on proprietary items like tyres, tubes, spark plug, battery etc., should be taken up with the respective manufacturer or their authorised agents in the area directly by the customer. RE shall not be liable in any manner to replace them through their dealers. RE will, however, provide assistance in referring such claims on the respective manufacturer.
7. Warranty shall not apply to:
 - (a) Normal ageing, deterioration or rusting of plated parts, paints coat, rubber parts, soft items, glass items, plastic parts etc.
 - (b) Components like fuel filter, oil filter, air filter paper element, control cables, brake shoes/brake pads, clutch plates, drive chain & sprocket kit, steering ball races, electrical equipment, wiring harness etc., which are subjected to normal wear and tear.
 - (c) Failures occurred due to use of non recommended grade lubricants, fuel or improper level.
 - (d) Damages due to use of non-genuine parts, lack of proper maintenance, incorrect riding habits.
 - (e) Damages to engine management system parts (like ECU, throttle body, sensors, etc.) due to tampering which affects the performance of the motorcycle.
 - (f) Parts damaged due to accidents, collision, abuse etc.
 - (g) Irregularities not recognised as affecting the quality or function of the motorcycle such as slight vibration, oil leakage, discoloration of exhaust pipe bend and cat region/silencer/soft or hard shock absorber etc.

WARRANTY TERMS & CONDITIONS

- (h) Warranty is not applicable for discoloration of exhaust pipe & silencer, as it is a natural process that will happen during usage.
 - (i) Defects arising from fitment of unauthorised or additional electrical loads.
 - (j) Motorcycle serviced or repaired at unauthorised service centres.
 - (k) Motorcycle used for competitions/racing/stage rallying etc.
 - (l) Electrical component like bulbs, fuses etc., and electronic components failure due to repairs by arc welding.
 - (m) Normal maintenance operations like adjustment of brakes, cleaning fuel system, engine tune-up and other such adjustments.
 - (n) Oxidization of buffed/painted/powder coated items etc.
8. Use only Royal Enfield approved parts and accessories. Use of certain other manufacturer's performance parts will void your new motorcycle warranty.
 9. RE reserves the right to finally decide on all warranty claims.
 10. RE reserves the right to make changes in design of the motorcycle without any obligation to install these changes on previously supplied motorcycles.

EMISSION CONTROL SYSTEM WARRANTY

YOUR WARRANTY RIGHTS AND OBLIGATIONS

The California Air Resources Board and Royal Enfield Motor Company are pleased to explain the emission control system warranty on your new motorcycle. In California, new motor vehicles must be designed, built and equipped to meet the State's stringent anti-smog standards. Royal Enfield Motor Company must warrant the emission control system on your motorcycle for the periods of time listed below provided there has been no abuse, unapproved modification, neglect or improper maintenance of your motorcycle.

Your emission control system may include parts such as the carburetor or fuel-injection system, the ignition system, catalytic converter, and engine computer. Also included may be hoses, connectors and other emission-related assemblies.

Where a warrantable condition exists, within the warranty period noted below, your authorized Royal Enfield dealer will repair your motorcycle at no cost to you including diagnosis, parts and labor.

EMISSION CONTROL SYSTEM WARRANTY

MANUFACTURER'S WARRANTY COVERAGE

For a period of use of five years or 30,000 km (18641 mi), whichever first occurs, beginning on the date the motorcycle is delivered to the ultimate purchaser or, if the motorcycle is placed in service as a demonstrator or company motorcycle prior to sale at retail, the date it is first placed in service.

If any emission related part on your motorcycle is defective, the part will be repaired or replaced by Royal Enfield Motor Company. This is your emission control system defects warranty.

OWNER'S WARRANTY RESPONSIBILITIES

As the motorcycle owner, you are responsible for the performance of the required maintenance listed in your Owner's Manual. Royal Enfield recommends that you retain all receipts covering maintenance on your motorcycle, but Royal Enfield cannot deny emissions warranty coverage solely for the lack of receipts or for your failure to ensure the performance of all scheduled maintenance.

EMISSION CONTROL SYSTEM WARRANTY

You are responsible for presenting your motorcycle to an authorized Royal Enfield dealer as soon as a problem exists. The warranty repairs should be completed in a reasonable amount of time, not to exceed 30 days.

As the motorcycle owner, you should also be aware that Royal Enfield may deny you warranty coverage if your motorcycle or a part has failed due to abuse, neglect, improper maintenance or unapproved modifications.

If you have any questions regarding your warranty rights and responsibilities, you should contact Royal Enfield Customer Service Department at 1-800-258-2464 (U.S. only) or 1-414-343-4056, or the California Air Resources Board at 9528 Telstar Ave., El Monte, California 91731.

ADDITIONAL WARRANTY TERMS

The warranty period starts the date the motorcycle is delivered to the ultimate purchaser or, if the motorcycle is placed in service as a demonstrator or company motorcycle prior to sale at retail, the date it is first placed in service. The emission control system of each new Royal Enfield motorcycle was designed, built and tested using only Genuine Royal Enfield parts and with these parts the motorcycle is certified as being in conformity with California emission control regulations.

EMISSION CONTROL SYSTEM WARRANTY

We recommend that you take your motorcycle to an authorized Royal Enfield dealer for repairs under this warranty. The dealer has factory-trained mechanics and genuine Royal Enfield parts. However, in the case of an "emergency" (as defined below), you could have repairs performed at any available service establishment or by the owner, using any replacement part. An authorized Royal Enfield dealer not being reasonably available, or a part not being available within a reasonable time period (not to exceed 30 days from the time the motorcycle is initially presented to a Royal Enfield dealer for repair) constitutes an emergency. Royal Enfield will reimburse the owner for such repairs, including diagnosis, only if it is established that the repairs are covered under this emission warranty. Royal Enfield's parts reimbursement, however, will not exceed our suggested retail price for all warranted parts replaced and our labor reimbursement will be limited to our recommended time allowances for emission system repairs at the geographically appropriate hourly labor rate.

To obtain reimbursement from Royal Enfield for such emergency repairs, you must keep all failed parts and original receipts, so you can present them to an authorized Royal Enfield dealer for inspection. Royal Enfield recommends that you bring your motorcycle to an authorized dealer for inspection to ensure that the emergency repairs were done properly.

EMISSION CONTROL SYSTEM WARRANTY

Remember: Use of non-Royal Enfield replacement parts may impair the effectiveness of the emission control system or otherwise damage your motorcycle. If other than genuine Royal Enfield parts are used for maintenance, replacement or repair of components affecting emission control, you should obtain written assurances that such non Royal Enfield parts are warranted by their manufacturer to be equal in quality to Genuine Royal Enfield parts in both performance and durability. The use of non-Royal Enfield replacement parts does not invalidate the existing warranty, if any, on other Royal Enfield components unless the non-Royal Enfield parts cause damage to warranted parts or result in the creation of an emissions non-compliant motorcycle. However, Royal Enfield assumes no liability under this warranty with respect to any parts which are not genuine Royal Enfield Parts, unless Royal Enfield Parts cause damage to non-genuine Royal Enfield Parts.

WHAT IS COVERED BY THIS EMISSION WARRANTY

The emission control system warranty covers the following "warranted parts" only:

Air cleaner assembly, cam shaft, spark plug, ignition coil, ignition wires, vapor valve, catalytic converter, crankcase, breather, MAP sensor, TMAP sensor, intakeair temperature sensor, throttle position sensor, fuel injectors, induction module or throttle body, engine temperature sensor, electronic control unit, oxygen sensors, carbon canister, purge control valve, fuel tank (non-cosmetic failures only), leaks, fuel vapor separator, fuel cap. If used on the above: hoses, clamps, fittings, tubing, sealing gaskets and mounting hardware.

EMISSION CONTROL SYSTEM WARRANTY

WHAT IS NOT COVERED BY THIS EMISSION WARRANTY

The emission control system warranty does not cover:

Malfunctions in any "warranted parts" caused by any of the following: abuse, misuse, unapproved modification or alteration, tampering, disconnection, or improper or inadequate maintenance. The warranty also does not cover replacement of listed parts in the event that the vehicle has been rendered emissions non-compliant in the state of California through actions noted above.

Damage resulting from accident, acts of nature or other events beyond the control of Royal Enfield.

The repair or replacement of "warranted parts" which are scheduled for replacement prior to 30,000 km (18641 mi), once these parts have been replaced at the first replacement interval as part of required maintenance services.

Repairs and services performed by anyone other than an authorized Royal Enfield Dealer (except in case of emergency as defined above).

Loss of time, inconvenience, loss of use of the motorcycle, towing of the vehicle, or commercial loss and/or consequential damages.

Repairs on any motorcycle of which odometer mileage has been changed so that mileage cannot be readily determined.

NOISE CONTROL SYSTEM WARRANTY

The following warranty applies to the noise control system and is in addition to the Limited Warranty, Emission Control System Warranty & California Air Resources Board Regulations. Evaporative Emission Control system Warranty. (Applicable only for motorcycles sold within the state of California.)

Royal Enfield Motors warrants the first owner and each subsequent owner, that this motorcycle is designed and built so as to conform, at the time of sale, with applicable regulations specified by the U.S. Federal Environmental Protection Agency and California Air Resources Board Regulations, that the Noise control system emission related parts fitted to this motorcycle are free from defects in materials and workmanship which may cause this motorcycle not to meet the U.S. Federal Environmental Protection Agency standards for a period of 5 years or 18,641 Miles (30,000 km), whichever occurs first, from the date of first use of the motorcycle.

The Warranty period shall begin, on the date the motorcycle is delivered to the first retail purchaser or from the first date the motorcycle is used as a demonstrator or as a display and/or trial motorcycle.

NOISE CONTROL SYSTEM WARRANTY

THE FOLLOWING ITEMS ARE NOT COVERED BY THE NOISE CONTROL SYSTEM WARRANTY:

1. Failures which may arise as a result of misuse, alterations, accidents or non performance of routine maintenance, as specified in the Owner's Manual.
2. Replacing or removing or modifying any portion of the Noise Control System (consisting of exhaust, air intake/cleaner assembly) with parts not certified to be genuine and noise legal in the USA for street use.
3. Loss of time, inconvenience, loss of motorcycle use or any other consequential loss or damages.
4. Any motorcycle in which the odometer has been tampered with, or the speedo cable has been disconnected for any reason or is broken and not replaced immediately, due to which the exact distance covered cannot be determined.

RECOMMENDATIONS FOR REQUIRED MAINTENANCE

It is recommended that the routine maintenance of the motorcycle be carried out at specified intervals and any maintenance to the noise control systems should be performed only by an authorised Royal Enfield service dealer and using only genuine Royal Enfield spare parts.

Repairs to the noise control system may be performed by any other qualified service outlet or individual and use of parts other than genuine Royal Enfield supplied parts is permissible, only if such agency or individuals and the non genuine parts used, are certified to comply with the U.S. Environmental protection agency standards.

EVAPORATIVE EMISSION CONTROL SYSTEM WARRANTY

The following warranty applies to the evaporative emission control system.

Royal Enfield motors warrants the first owner and each subsequent owner, that this motorcycle is designed and built so as to conform, at the time of sale, with applicable regulations specified by the evaporative emission control system related parts fitted to this motorcycle are free from defects in materials and workmanship which may cause this motorcycle not to meet applicable regulations period of 24 months from the date of first use of the motorcycle.

The Warranty period shall begin either on the date the motorcycle is delivered to the first retail purchaser or from the first date the motorcycle is used as a demonstrator or as a display and / or trial motorcycle.

THE FOLLOWING ARE NOT COVERED BY THE EVAPORATIVE EMISSION CONTROL SYSTEM WARRANTY

1. Failures which may arise as a result of misuse, alterations, accidents or non performance of routine maintenance, as specified in the owner's manual.
2. Replacing, removing or modifying any portion of the Evaporative Emission Control System (consisting of fuel tank, fuel tank cap, canister, purge valve, throttle body, vapor hoses, fuel hoses and hose connectors) with parts not certified by Royal Enfield.

EVAPORATIVE EMISSION CONTROL SYSTEM WARRANTY

3. Loss of time, inconvenience, loss of motorcycle use or any other consequential loss or damages.
4. Any motorcycle in which the ODO meter has been tampered with or the speedo cable has been disconnected for any reason or is broken and not replaced immediately, due to which the exact distance covered cannot be determined.
5. Normal ageing of parts such as fuel hoses, vapor hoses, gaskets and rubber components.

RECOMMENDATIONS FOR REQUIRED MAINTENANCE

It is recommended that the routine maintenance of the motorcycle be carried out at specified intervals and any maintenance to the evaporative emission control systems should be performed only by an Authorised Royal Enfield Service Centre and using only genuine Royal Enfield spare parts.

Repairs to the evaporative emission control system may be performed by any other qualified service outlet or individual and use of parts other than genuine Royal Enfield supplied parts is permissible. only if such agency or individuals and the non genuine parts used, are certified to comply with the California air resources board.

RADIO TYPE APPROVAL

TRIPPER/NAVIGATION DISPLAY UNIT - USA

FCC ID: NT8- JDCP

FCC§ 15.19 Labelling requirements
This device complies with part 15 of the FCC Rules and Innovation, Science and Economic Development Canada (ISED) license-exempt RSS standard(s).
Operation is subject to the following two conditions:

- (1) This device may not cause harmful interference, and
 - (2) this device must accept any interference received, including interference that may cause undesired operation.
- FCC§ 15.21 Information to user Changes or modifications not expressly approved by the party responsible for compliance could void the user's authority to operate the equipment.
FCC §15.105 statement This equipment has been tested and found to comply with the limits for a Class B digital device. pursuant to part 15 of the FCC Rules. These limits are designed to provide reasonable protection



against harmful interference in a residential installation. This equipment generates, uses and can radiate radio frequency energy and, if not installed and used in accordance with the instructions, may cause harmful interference to radio communications. However, there is no guarantee that interference will not occur in a particular installation. If this equipment does cause harmful interference to radio or television reception, which can be determined by turning the equipment off and on, the user is encouraged to try to correct the interference by one or more of the following measures:

- Reorient or relocate the receiving antenna.
- Increase the separation between the equipment and receiver.
- Connect the equipment into an outlet on a circuit different from that to which the receiver is connected.
- Consult the dealer or an experienced radio/TV technician for help.

RF Exposure Requirements
To comply with FCC RF exposure compliance requirements, the device must be installed to provide a separation distance of at least 20 cm from all persons.

SERVICE/MAINTENANCE RECORD

S.No.	Type of service	Schedule	Date	Job card No.	km/ mile	Dealer code	Brief details of service
1.							
2.							
3.							
4.							
5.							
6.							
7.							

WIRING DIAGRAM

DISCLAIMER

It is recommended that the wiring circuit repair and any other electrical rework should be performed only by an Authorized Royal Enfield Service Centre, failure to adhere this may cause damage to electrical systems and render the warranty of the products as void.



NOTE



ROYAL ENFIELD

Part No. RAM00587/A

WWW.ROYALENFIELD.COM

Edition: October 2022