

Part Number:

1990211

Models:

Himalayan

WARNING: Royal Enfield genuine accessories are designed to fit only the specific Royal Enfield motorcycle(s) that are specified above. They should not be fitted to any other type of motorcycle. Pay particular attention to the warnings and cautions contained in this instruction, failure to do so may result in an incorrect installation of the accessory which could result in an unsafe riding condition and possible accident. If in any doubt always seek the help from your authorised Royal Enfield dealer.

WARNING: Before starting any accessory kit installation ensure the motorcycle is supported in a stable condition. Failure to support the motorcycle correctly could lead to motorcycle damage or personal injury.

WARNING: All fixings must be tightened to the torque values specified in this instruction. Failure to tighten fixings to the correct torque could result in an unsafe riding condition and possible accident.

CAUTION: Care should be taken when fitting any accessory kit. Incorrect handling kit components or the use of incorrect tools could lead to component or motorcycle damage.

NOTE: The content of this instruction is subject to change at any time without notice or liability. Royal Enfield reserves the right to revise the information presented at any time.

NOTE: This accessory handguard kit is suitable for fitment to motorcycles fitted with original equipment handlebars only. This accessory handguard kit must not be used if the motorcycle is fitted with accessory handlebars.

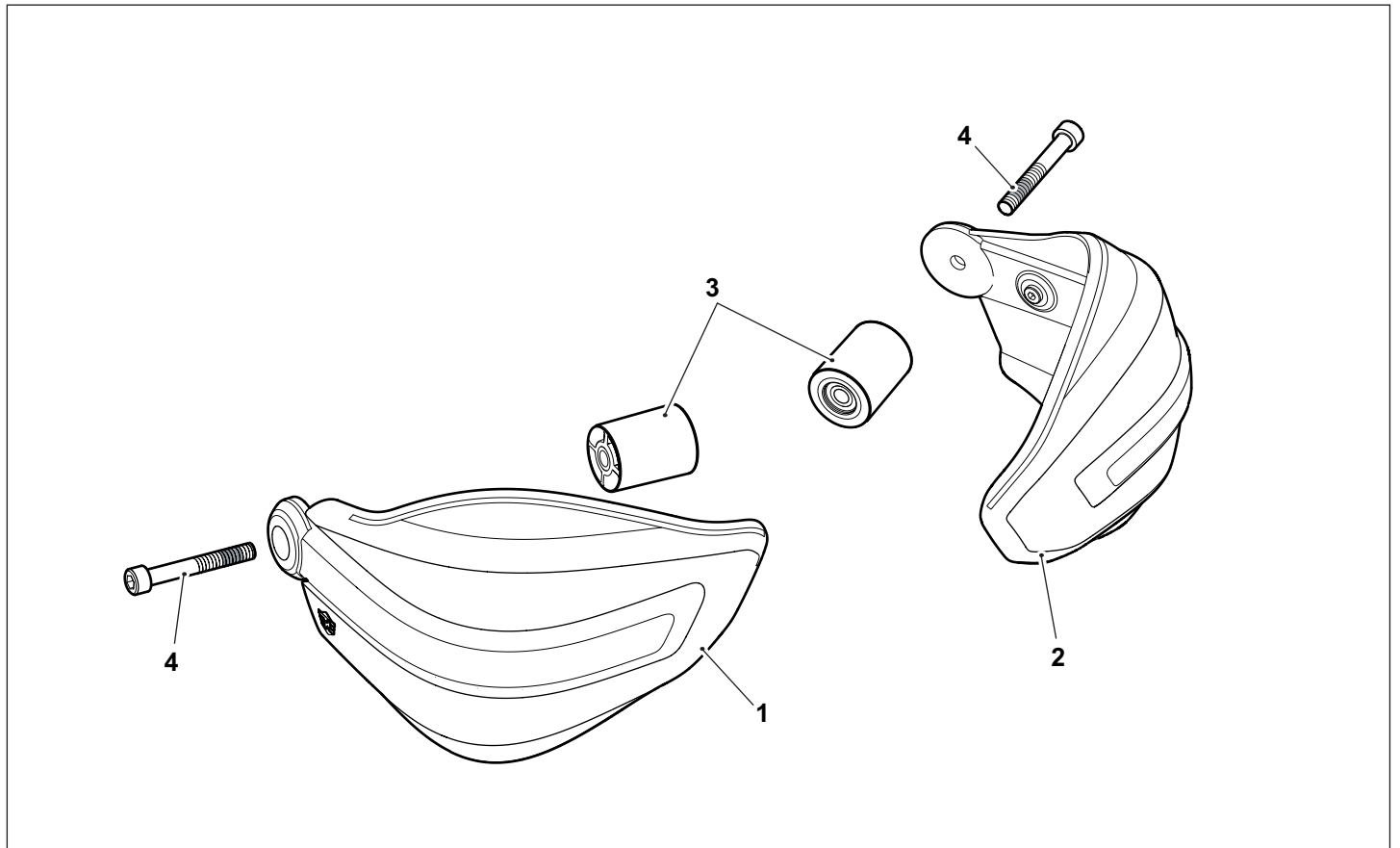

Item	Description	Qty
1	Handguard, right hand	1
2	Handguard, left hand	1
3	Bar end weight	2
4	Fixing, (patch locked)	2

1 Remove the bar end weight (1) from the left hand side of the handlebars. Retain the bar end weight (1) and fixing (2) for re-use if the accessory handguards are to be removed.

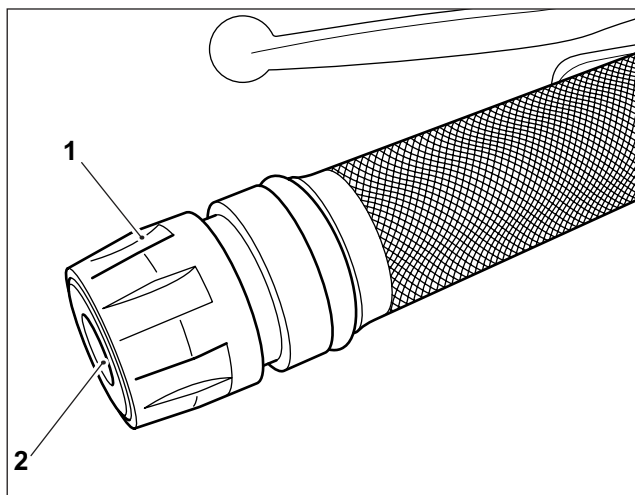

⚠ WARNING: The fixings provided in the kit include a patch locking compound to the threads and must never be reused. If the fixings are removed they should be discarded and replaced with new fixings. An insecure fixing could lead to the handguard and bar end weight becoming detached and result in loss of motorcycle control and an accident.

2 Assemble the left hand handguard (1), a bar end weight (2) and fixing (3) from the kit, as shown.

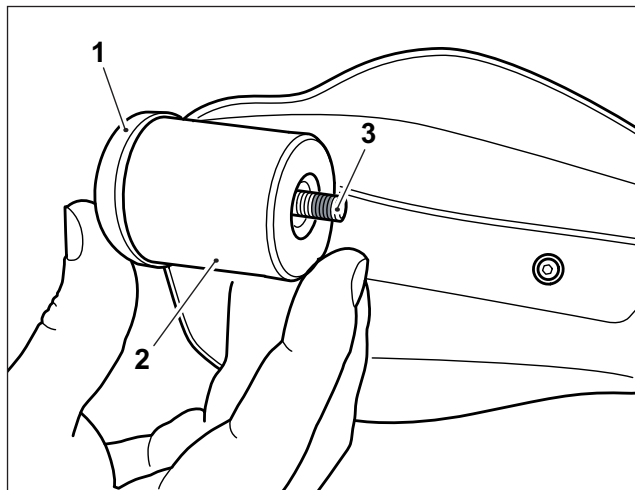

3 Fit the bar end weight (1) into the left hand side of the handlebars. Adjust the position of the handguard (2) to the preferred position and tighten the fixing (3) to **20 Nm**.

	6mm Allen socket with torque wrench
---	-------------------------------------

4 Repeat steps 1 to 3 for the right hand side of the motorcycle.

⚠ WARNING: Ensure that the operation of the twist grip is smooth, without tightness and will return to the throttle closed position when released. A tight or sticking twist grip can lead to loss of motorcycle control and an accident.

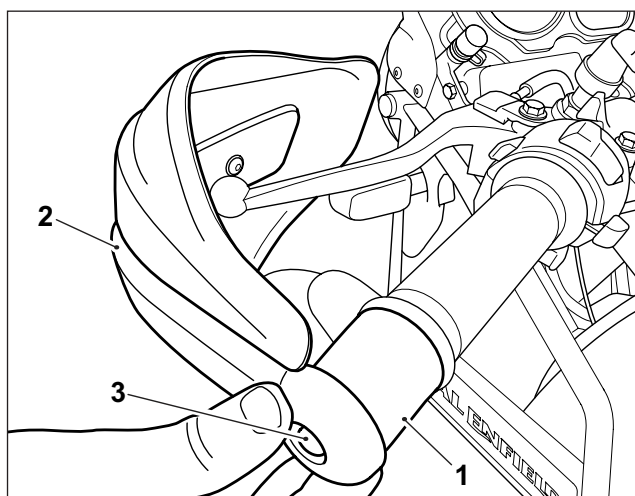

⚠ WARNING: Move the handlebars to the left hand and right hand full lock positions and check that the handguards do not contact any part of the motorcycle, or restrict the steering. Any restriction in motorcycle steering may cause the motorcycle to become unstable and result in an accident.

⚠ WARNING: After fitting any genuine Royal Enfield accessory always ride the motorcycle with caution and allow time to become familiar with any change in the motorcycle handling characteristics. Failure to become familiar with any change in the motorcycle handling characteristics may cause the motorcycle to become unstable and result in an accident.