

Write your name here

Surname

Other names

**Pearson Edexcel**

Centre Number

Candidate Number

Level 1/Level 2 GCSE (9-1)

# Mathematics

Paper 3 (Calculator)

Higher Tier

Tuesday 12 June 2018 – Morning

Time: 1 hour 30 minutes

Paper Reference

**1MA1/3H**

**You must have:** Ruler graduated in centimetres and millimetres, protractor, pair of compasses, pen, HB pencil, eraser, calculator. Tracing paper may be used.

Total Marks

## Instructions

- Use **black** ink or ball-point pen.
- **Fill in the boxes** at the top of this page with your name, centre number and candidate number.
- Answer **all** questions.
- Answer the questions in the spaces provided – *there may be more space than you need.*
- You must **show all your working**.
- Diagrams are **NOT** accurately drawn, unless otherwise indicated.
- **Calculators may be used.**
- If your calculator does not have a  $\pi$  button, take the value of  $\pi$  to be 3.142 unless the question instructs otherwise.



## Information

- The total mark for this paper is 80
- The marks for **each** question are shown in brackets – *use this as a guide as to how much time to spend on each question.*

## Advice

- Read each question carefully before you start to answer it.
- Keep an eye on the time.
- Try to answer every question.
- Check your answers if you have time at the end.

Answer **ALL** questions.

Write your answers in the spaces provided.

You must write down **all** the stages in your working.

- 1 The scatter diagram shows information about 12 girls.

It shows the age of each girl and the best time she takes to run 100 metres.

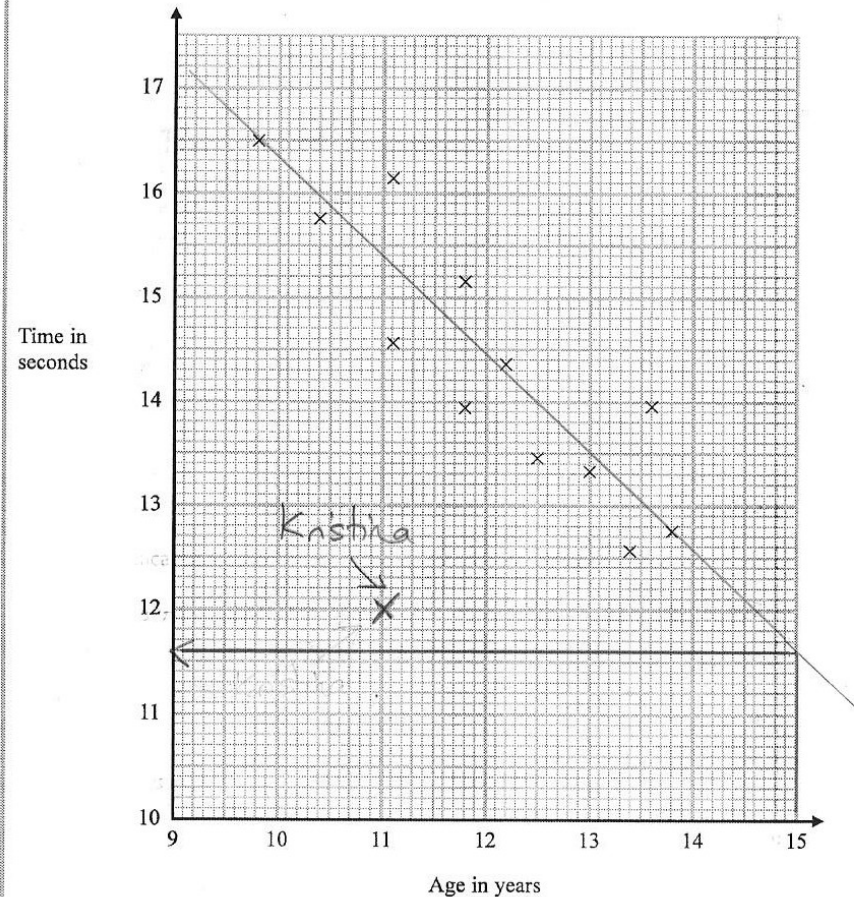

- (a) Write down the type of correlation.

Negative

(1)

Kristina is 11 years old.  
Her best time to run 100 metres is 12 seconds.

The point representing this information would be an outlier on the scatter diagram.

(b) Explain why.

The point for Kristina is far away from the line of best fit (shown)

(1)

Debbie is 15 years old.

Debbie says,

"The scatter diagram shows I should take less than 12 seconds to run 100 metres."

(c) Comment on what Debbie says.

This is outside the range of given data, so is an unreliable prediction (extrapolation)

(1)

(Total for Question 1 is 3 marks)

2 Expand and simplify  $5(p+3) - 2(1-2p)$

$$= 5p + 15 - 2 + 4p$$

$$= 9p + 13$$

$$\underline{\underline{9p + 13}}$$

(Total for Question 2 is 2 marks)

3 Here is a trapezium drawn on a centimetre grid.

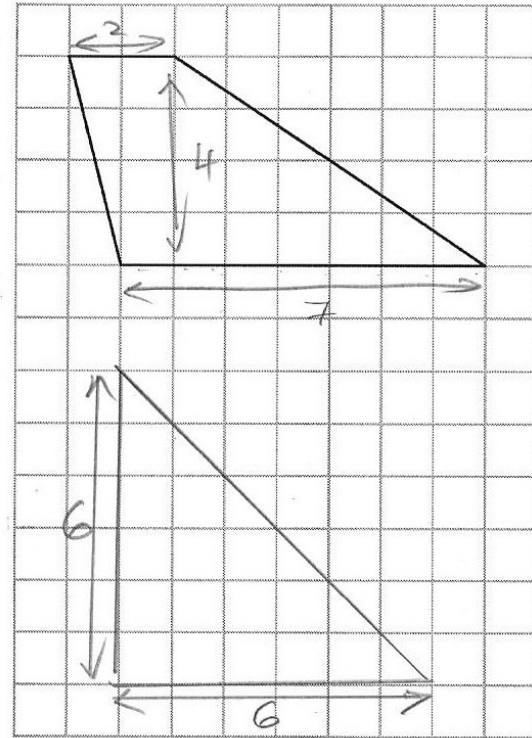

On the grid, draw a triangle equal in area to this trapezium.

$$\begin{aligned} \text{Area of trapezium} &= \frac{1}{2}(a+b)h = \frac{1}{2}(2+7)(4) \\ &= 18 \end{aligned}$$

$$\text{Area of triangle} = \frac{1}{2}bh = 18$$

$$\Rightarrow bh = 36$$

Different options, e.g. base = 6, height = 6  
[or base = 9, height = 4 etc]

(Total for Question 3 is 2 marks)

- 4 When a biased 6-sided dice is thrown once, the probability that it will land on 4 is 0.65  
The biased dice is thrown twice.

Amir draws this probability tree diagram.  
The diagram is **not** correct.

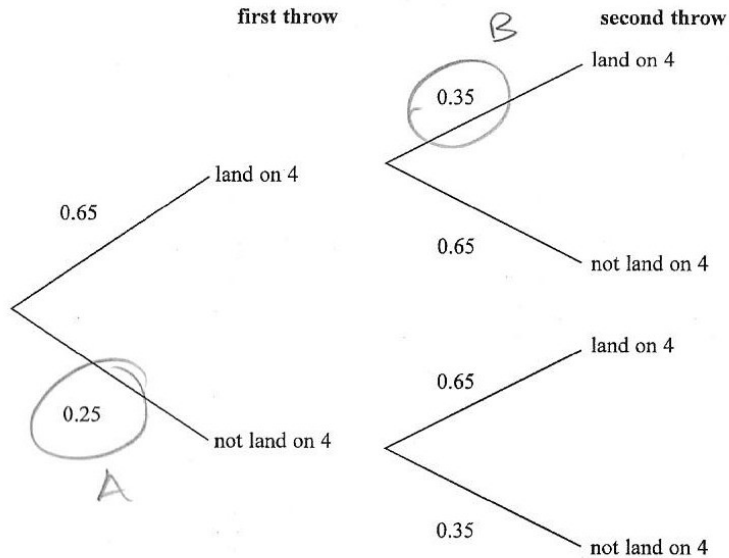

Write down **two** things that are wrong with the probability tree diagram.

- The probability marked (A) should be 0.35
- The probability marked (B) should be 0.65

(Total for Question 4 is 2 marks)

- 5  $ABC$  is a right-angled triangle.

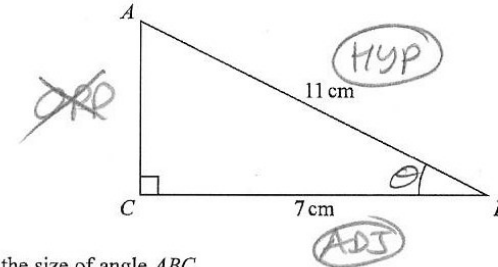

SOH  
CAH  
TOA

- (a) Work out the size of angle  $ABC$ .  
Give your answer correct to 1 decimal place.

$$\cos \theta = \frac{\text{ADJ}}{\text{HYP}}$$

$$\cos \theta = \frac{7}{11}$$

$$\theta = \cos^{-1}\left(\frac{7}{11}\right) = 50.4788\dots$$

50.5°  
(2)

The length of the side  $AB$  is reduced by 1 cm.

The length of the side  $BC$  is still 7 cm.  
Angle  $ACB$  is still  $90^\circ$

- (b) Will the value of  $\cos ABC$  increase or decrease?  
You must give a reason for your answer.

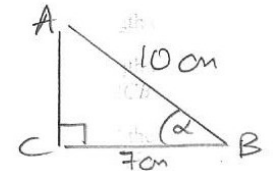

Before,  $\cos ABC = \frac{7}{11} = 0.636\dots$

After,  $\cos ABC = \frac{7}{10} = 0.7$  so it has increased

(1)

(Total for Question 5 is 3 marks)

- 6 There are some counters in a bag.  
The counters are red or white or blue or yellow.

Bob is going to take at random a counter from the bag.

The table shows each of the probabilities that the counter will be blue or will be yellow.

| Colour      | red | white | blue | yellow |
|-------------|-----|-------|------|--------|
| Probability |     |       | 0.45 | 0.25   |

There are 18 blue counters in the bag.

The probability that the counter Bob takes will be red is twice the probability that the counter will be white.

- (a) Work out the number of red counters in the bag.

1. Let  $P(\text{white}) = p$

2. So  $P(\text{red}) = 2p$

then  $2p + p + 0.45 + 0.25 = 1$

$3p = 0.3 \Rightarrow p = 0.1$

$P(\text{red}) = 2p = 0.2$

(blue) =  $0.45 \rightarrow 18$  counters  
 $1.0 \rightarrow 40$  counters  $\leftarrow \div 0.45$   
 (red) =  $0.2 \rightarrow 8$  counters  $\leftarrow \times 0.2$

(4)

A marble is going to be taken at random from a box of marbles.  
The probability that the marble will be silver is 0.5

There must be an even number of marbles in the box.

- (b) Explain why.

$P(\text{silver}) = 0.5 = \frac{1}{2}$ . If the number of marbles was odd, the  $P(\text{silver})$  could not equal to  $\frac{1}{2}$ .

(1)

(Total for Question 6 is 5 marks)

7 Solve  $\frac{5-x}{2} = 2x-7$

$(\frac{5-x}{2}) \times 2 = (2x-7) \times 2$

$5-x = 4x-14$

$-x-4x = -14-5$

$+5x = +19$

$x = \frac{19}{5} = 3\frac{4}{5}$

$x = 3\frac{4}{5}$

(Total for Question 7 is 3 marks)

OR 3.8  
OR 19/5

8  $ABCDE$  is a pentagon.

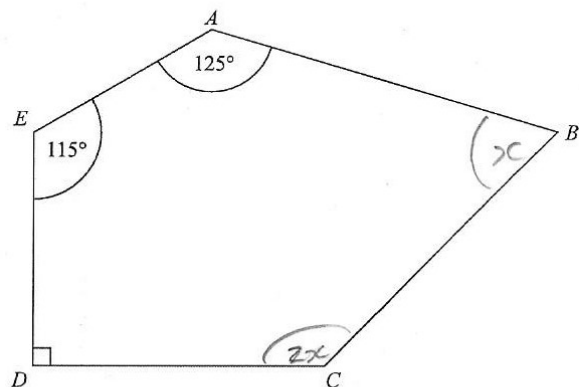

Angle  $BCD = 2 \times$  angle  $ABC$

Work out the size of angle  $BCD$ .  
You must show all your working.

Let  $\angle ABC = x$

then  $\angle BCD = 2x$

Total of interior angles  $= 3 \times 180$   
 $= 540^\circ$



$$\therefore 115 + 125 + x + 2x + 90 = 540$$

$$3x + 330 = 540$$

$$3x = 210$$

$$x = 70^\circ$$

$$\therefore \angle BCD = 2 \times 70$$

$$= 140^\circ$$

140

(Total for Question 8 is 5 marks)

$$9 \quad T = \sqrt{\frac{w}{d^3}}$$

$$w = 5.6 \times 10^{-5}$$

$$d = 1.4 \times 10^{-4}$$

(a) Work out the value of  $T$ .

Give your answer in standard form correct to 3 significant figures.

$$T = \sqrt{\frac{5.6 \times 10^{-5}}{(1.4 \times 10^{-4})^3}} = 4517.5395...$$

$$= 4.5175395... \times 10^3$$

$$= 4.52 \times 10^3$$

$$T = \underline{\underline{4.52 \times 10^3}}$$

(2)

$w$  is increased by 10%  
 $d$  is increased by 5%

Lottie says,

"The value of  $T$  will increase because both  $w$  and  $d$  are increased."

(b) Lottie is wrong.  
Explain why.

$$\text{new } w = 5.6 \times 10^{-5} \times 1.1$$

$$= 6.16 \times 10^{-5}$$

$$\text{new } d = 1.4 \times 10^{-4} \times 1.05$$

$$= 1.47 \times 10^{-4}$$

$$\text{new } T = 4403.685...$$

Lottie is wrong, as  $T$  has decreased from  
4518 to 4404

(2)

(Total for Question 9 is 4 marks)

10 Here are three lamps.

lamp A



lamp B



lamp C



Lamp A flashes every 20 seconds.

Lamp B flashes every 45 seconds.

Lamp C flashes every 120 seconds.

The three lamps start flashing at the same time.

How many times in one hour will the three lamps flash at the same time?

$$A = 20, 40, 60, 80, 100, 120, 140, 160, \\ 180, 200, 220, 240, \dots$$

$$B = 45, 90, 135, 180, 225, 270, 315, \\ \textcircled{360}, 405, 450, 495, 540, \dots$$

$$C = 120, 240, \textcircled{360}, 480, 600, \dots$$

$$\text{LCM} = 360 \text{ secs} = 6 \text{ mins}$$

Lamps flash at the same time every 6 mins,  
ie. 10 times per hour

10

(Total for Question 10 is 3 marks)

11 In 2003, Jerry bought a house.

In 2007, Jerry sold the house to Mia.  
He made a profit of 20%

In 2012, Mia sold the house for £162 000  
She made a loss of 10%

Work out how much Jerry paid for the house in 2003

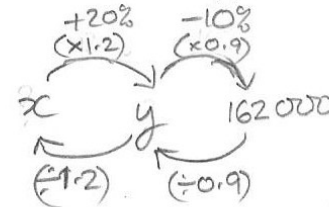

$$y = \text{price in 2007} = 162\,000 \div 0.9 \\ = 180\,000$$

$$x = \text{price in 2003} = 180\,000 \div 1.2 \\ = 150\,000$$

£ 150 000

(Total for Question 11 is 3 marks)

12 The graph shows the volume of liquid ( $L$  litres) in a container at time  $t$  seconds.

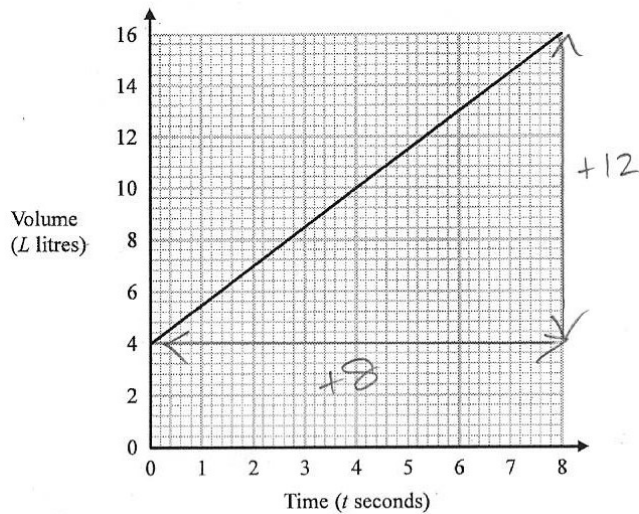

(a) Find the gradient of the graph.

$$\text{Grad} = \frac{\text{d.y}}{\text{d.x}} = \frac{12}{8} = \frac{3}{2}$$

(b) Explain what this gradient represents.

$\frac{3}{2} = 1.5$  litres per second. This represents the increase of liquid in the tank per second.

The graph intersects the volume axis at  $L = 4$

(c) Explain what this intercept represents.

$L = 4$  litres. This represents the amount of liquid in the tank at the start.

(Total for Question 12 is 4 marks)

13 Here are two similar solid shapes.

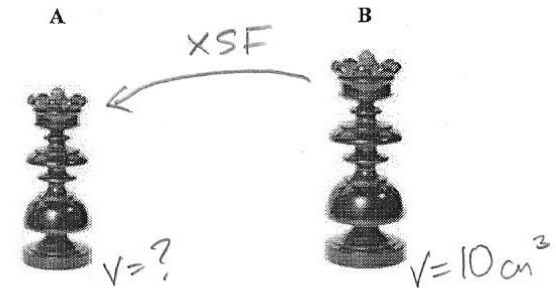

surface area of shape A : surface area of shape B = 3 : 4

The volume of shape B is  $10 \text{ cm}^3$

Work out the volume of shape A.

Give your answer correct to 3 significant figures.

$$\text{Area scale factor} = \text{ASF} = (\text{SF})^2$$

$$\text{Ratio of areas} = 3:4$$

$$\therefore \text{ASF} = \frac{3}{4} \text{ so } (\text{SF})^2 = \frac{3}{4}$$

$$\text{SF} = \sqrt{\frac{3}{4}} = \frac{\sqrt{3}}{2} (=0.866)$$

$$\text{New vol} = \text{old vol} \times \text{SF}^3$$

$$= 10 \times \left(\frac{\sqrt{3}}{2}\right)^3$$

$$= \frac{15\sqrt{3}}{4} = 6.49519\dots$$

6.50  $\text{cm}^3$

(Total for Question 13 is 3 marks)

- 14 There are 16 hockey teams in a league.  
Each team played two matches against each of the other teams.

Work out the total number of matches played.

Each team plays  $2 \times 15 = 30$  matches.  
If 16 teams play 30 matches,  
then  $16 \times 30 = 480$  matches  
However each match counted twice,  
so actual number of matches =  $480 \div 2$   
= 240

240

(Total for Question 14 is 2 marks)

Alternative method

- If teams are A, B, C, D, ...
- Imagine a table showing A v B and B v A.
- Cross out A v A (team cannot play itself)
- Number of matches = (columns)  $\times$  (rows) - (crosses)  
=  $16 \times 16 - 16$   
= 240

|   | A | B | C | D |
|---|---|---|---|---|
| A | X |   |   |   |
| B |   | X |   |   |
| C |   |   | X |   |
| D |   |   |   | X |

- 15 The graph shows the speed of a car, in metres per second, during the first 20 seconds of a journey.

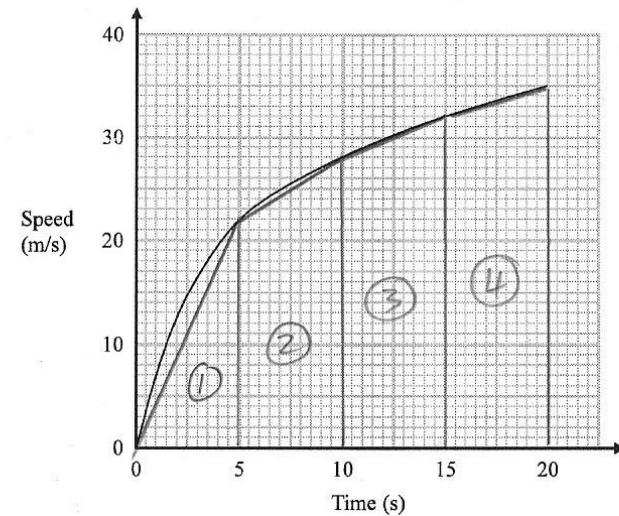

- (a) Work out an estimate for the distance the car travelled in the first 20 seconds.  
Use 4 strips of equal width.

Distance covered = Area under graph  
Area of ① =  $\frac{1}{2}bh = \frac{1}{2}(5)(22) = 55$   
Area of ② =  $\frac{1}{2}(a+b)h = \frac{1}{2}(22+28)(5) = 125$   
Area of ③ =  $\frac{1}{2}(28+32)(5) = 150$   
Area of ④ =  $\frac{1}{2}(32+35)(5) = 167.5$   
Total =  $55 + 125 + 150 + 167.5$   
= 497.5

497.5 metres

(3)

- (b) Is your answer to part (a) an underestimate or an overestimate of the actual distance the car travelled in the first 20 seconds?  
Give a reason for your answer.

Answer is an underestimate, as tops of trapeziums are below the actual curve. (1)

(Total for Question 15 is 4 marks)

- 16 The  $n$ th term of a sequence is given by  $an^2 + bn$  where  $a$  and  $b$  are integers.

The 2nd term of the sequence is  $-2$

The 4th term of the sequence is  $12$

- (a) Find the 6th term of the sequence.

$$\begin{aligned} \text{If } n=2, \quad 2^{\text{nd}} \text{ term} &= a(2)^2 + b(2) = -2 \\ &\Rightarrow 4a + 2b = -2 \\ &2a + b = -1 \quad \text{--- (1)} \end{aligned}$$

$$\begin{aligned} \text{If } n=4, \quad 4^{\text{th}} \text{ term} &= a(4)^2 + b(4) = 12 \\ &16a + 4b = 12 \\ &4a + b = 3 \quad \text{--- (2)} \end{aligned}$$

$$\text{(2) - (1)}$$

$$2a = 4$$

$$a = 2$$

Sub in (1)

$$4 + b = -1$$

$$b = -5$$

$$6^{\text{th}} \text{ term} = 2(6)^2 - 5(6) =$$

$$\underline{\underline{42}} \quad (4)$$

Here are the first five terms of a different quadratic sequence.

0    2    6    12    20

- (b) Find an expression, in terms of  $n$ , for the  $n$ th term of this sequence.

|       |      |    |    |    |    |    |
|-------|------|----|----|----|----|----|
|       |      | +2 | +2 | +2 |    |    |
|       | +2   | +4 | +6 | +8 |    |    |
| seq   | = 0  | 2  | 6  | 12 | 20 |    |
| $n^2$ | = 1  | 4  | 9  | 16 | 25 |    |
|       |      | -1 | -2 | -3 | -4 | -5 |
| $-n$  | = -1 | -2 | -3 | -4 | -5 |    |
|       |      | 0  | 0  | 0  | 0  |    |

$$n^{\text{th}} \text{ term} = n^2 - n$$

$$\underline{\underline{n^2 - n}} \quad (2)$$

(Total for Question 16 is 6 marks)

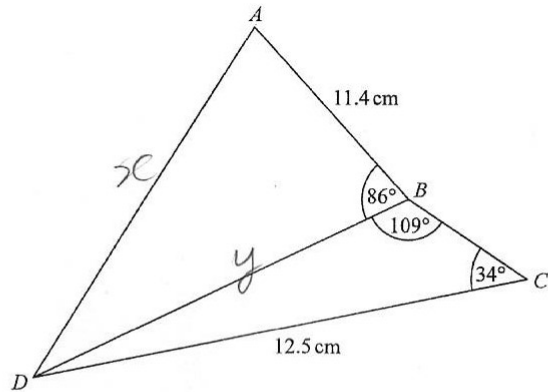

Work out the length of  $AD$ .  
Give your answer correct to 3 significant figures.

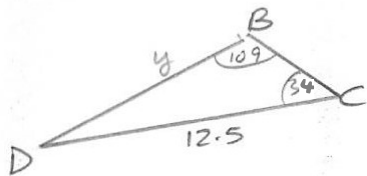

$$\frac{y}{\sin 34} = \frac{12.5}{\sin 109}$$

$$y = \frac{12.5 \sin 34}{\sin 109}$$

$$y = 7.39267\dots$$

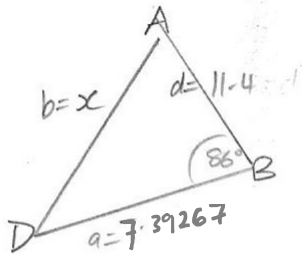

$$b^2 = a^2 + d^2 - 2ad \cos B$$

$$x^2 = 11.4^2 + 7.39267^2 - 2(11.4)(7.39267) \cos 86$$

$$x^2 = 172.8639\dots$$

$$x = \underline{\underline{13.147\dots}}$$

13.1

cm

(Total for Question 17 is 5 marks)

18 (a) Show that the equation  $x^3 + x = 7$  has a solution between 1 and 2

$$\text{If } x=1, \quad x^3 + x = 1^3 + 1 = 2 \quad (\text{too small})$$

$$\text{If } x=2, \quad x^3 + x = 2^3 + 2 = 10 \quad (\text{too big})$$

so must be a solution between  $x=1$  and  $x=2$

(2)

(b) Show that the equation  $x^3 + x = 7$  can be rearranged to give  $x = \sqrt[3]{7-x}$ 

$$x^3 = 7 - x$$

$$x = \sqrt[3]{7-x}$$

(1)

(c) Starting with  $x_0 = 2$ , use the iteration formula  $x_{n+1} = \sqrt[3]{7-x_n}$  three times to find an estimate for a solution of  $x^3 + x = 7$

$$x_0 = 2$$

$$x_1 = \sqrt[3]{7-2} = 1.709975\dots$$

$$x_2 = \sqrt[3]{1.709975-2} = 1.742418\dots$$

$$x_3 = 1.7388495\dots$$

Solution is approx 1.74 (3 sf)

1.74

(3)

(Total for Question 18 is 6 marks)

19 Here are two right-angled triangles.

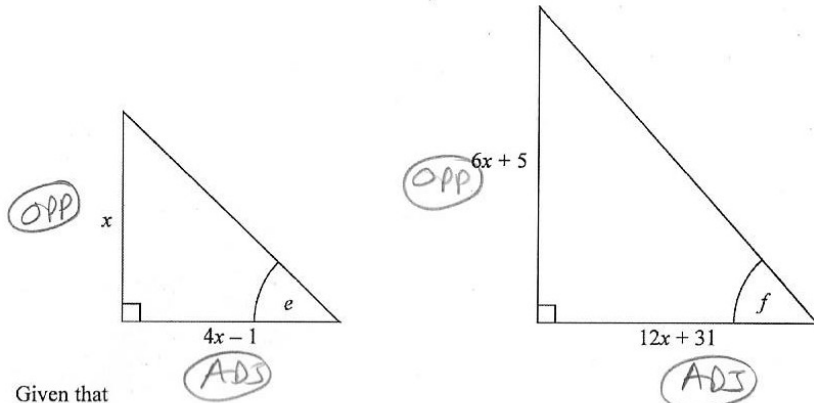

Given that

$$\tan e = \tan f$$



find the value of  $x$ .

You must show all your working.

$$\tan e = \frac{\text{OPP}}{\text{adj}} = \frac{x}{4x-1}$$

$$\tan f = \frac{6x+5}{12x+31}$$

Using  $*$  
$$\frac{x}{4x-1} = \frac{6x+5}{12x+31}$$

$$x(12x+31) = (6x+5)(4x-1)$$

$$12x^2 + 31x = 24x^2 - 6x + 20x - 5$$

$$12x^2 + 31x - 24x^2 + 6x - 20x + 5 = 0$$

$$-12x^2 + 17x + 5 = 0$$

$$(x-1) \quad 12x^2 - 17x - 5 = 0$$

$$(3x-5)(4x+1) = 0$$

$$x = \frac{5}{3} \text{ or } x = -\frac{1}{4}$$

$x$  cannot be negative!

$$x = \frac{5}{3}$$

(Total for Question 19 is 5 marks)

20 50 people were asked if they speak French or German or Spanish.

Of these people,

31 speak French

2 speak French, German and Spanish

4 speak French and Spanish but not German

7 speak German and Spanish

8 do not speak any of the languages

all 10 people who speak German speak at least one other language

Two of the 50 people are chosen at random.

Work out the probability that they both only speak Spanish.

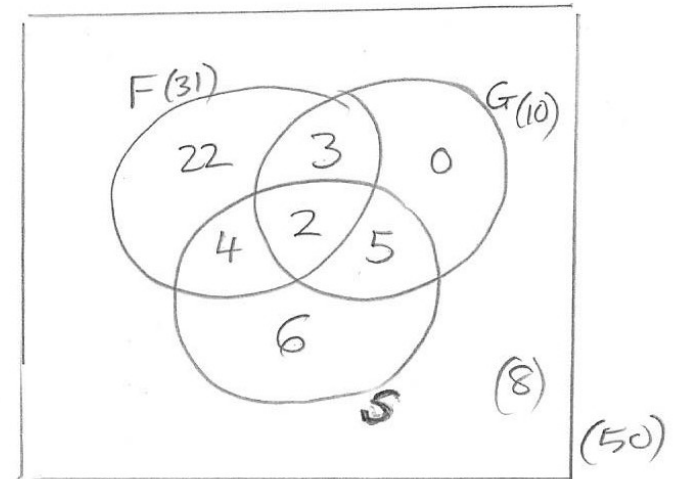

$$P(\text{both people speak only Spanish}) = \frac{6}{50} \times \frac{5}{49}$$

$$= \frac{3}{245}$$

$$\frac{3}{245}$$

(Total for Question 20 is 5 marks)

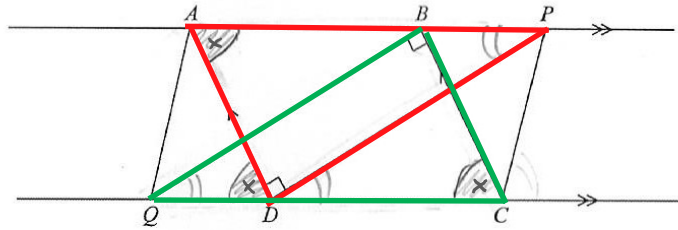

$ABCD$  is a parallelogram.

$ABP$  and  $QDC$  are straight lines.

Angle  $ADP = \text{angle } CBQ = 90^\circ$

(a) Prove that triangle  $ADP$  is congruent to triangle  $CBQ$ .

$\angle PAD = \angle ADQ$  (alternate angles)  
and  $\angle ADQ = \angle BCQ$  (corresponding angles)

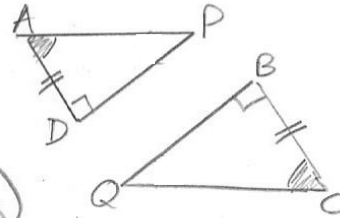

So  $\angle PAD = \angle BCQ$

Also length  $AD = \text{length } BC$  (opposite sides of a parallelogram)

$\therefore$  congruent triangles (AAS)

(3)

(b) Explain why  $AQ$  is parallel to  $PC$ .

From (a), triangles  $ADP$  and  $CBQ$  are congruent, so  $AP$  and  $QC$  are equal in length.

We also know  $AC$  and  $QC$  are parallel.

So  $AQPC$  is a parallelogram, which means  $AQ$  is parallel to  $PC$ .

(2)

(Total for Question 21 is 5 marks)

TOTAL FOR PAPER IS 80 MARKS