

Owner's Manual

JAMINAR
400
BS VI



THE WORLD'S
FAVOURITE
INDIAN





THE ALL NEW
**DOMINAR
400**

WELCOME TO THE DOMINAR CLAN!

You are now the proud owner of a modern masterpiece, Dominar 400 BS VI. The new Dominar 400 BS VI is designed to deliver unparalleled technology with superior performance. This makes your Dominar, unbeatable and unchallenged on every terrain.

Before you ride out, please read this Owner's Manual carefully and familiarise yourself with the operation mechanism, controls and maintenance requirements of your Dominar 400 BS VI. This will ensure you a safe and trouble free ownership experience.

To keep your bike in perfect running condition and deliver consistent performance, we have specially programmed the periodic maintenance services which includes 3 free services and subsequent paid services, as per the schedule contained in this booklet. We earnestly advise you to avail all these services at any of our Bajaj Dealers, who

are well equipped with all necessary facilities, genuine parts, oils and trained manpower to ensure the best care for your Dominar. Your '**Dominar 400 BS VI**' comes with a warranty of **5 years or 75,000 KMs**, whichever occurs earlier from the date of sale. For details please refer to "Warranty: Scope & Limits" given in this manual.

Should you require any addition information, feel free to contact us on helpline numbers given on backside of cover page or e-mail us at: customerservice@bajajauto.co.in or visit the Bajaj Auto website www.bajajauto.com Also, do like our Facebook page www.facebook.com/BajajDominar and subscribe to our YouTube channel to stay tuned on any new information on the brand.

DON'T HOLD BACK!!

TABLE OF CONTENTS

SR.	DESCRIPTION	PG. NO.	SR.	DESCRIPTION	PG. NO.
1.	Technical Specification	1	17.	Good Riding Habits	28
2.	Identification Data	3.	18.	Safe Riding Tips & Monsoon Care	29
3.	Location of Parts	4	19.	Engine Oil	30
4.	Steering cum Ignition lock	5	20.	Tubeless Tyre&Tyre Pressure	31
5.	Fuel Tank Cap & Secondary Speedometer	6	21.	Battery	32
6.	Primary Speedometer Details	7	22.	Engine Cooling System	33
7.	Twin Channel ABS System	8	23.	Coolant	34
8.	Speedometer Functionality Details	9	24.	Periodic Maintenance Information	35
9.	Secondary Speedometer Setting	17	25.	Brake Fluid / Headlamp Care	37
10.	Control Switch RH	19	26.	Usage of luggage straps with bungee cord	38
11.	Automatic Headlamp & Lights Operation	20	27.	Free Service Guidelines	39
12.	Control Switch LH	21	28.	Periodic Maintenance & Lubrication Chart	40
13.	Removal of Pillion & Rider Seat / Tool kit	22	29.	Non Use Maintenance	48
14.	Fitment of Rider & Pillion Seat	23	30.	Delivery Certificate	49
15.	Daily Safety Checks	24	31.	Warranty Scope & Limit	50
16.	How to ride your Bike	25	32.	Battery Warranty Card	53

SAFETY AND WARNING INFORMATION:



Warning: This indicates that a potential hazard or injury to you or other persons & to the vehicle can happen if advice provided is not followed.



Caution: This indicates that a potential hazard that could result in vehicle damage. Follow the Advice provided with the caution.

NOTICE

The description and illustration in this booklet are not to be taken as binding on the manufacturers. The essential features of the type described and illustrated herein remaining unaltered. Bajaj Auto Limited reserves the right to carry out at any moment without being obliged to bring this booklet upto-date & to do modifications on the vehicle, parts or accessories as may be convenient and necessary.

TECHNICAL SPECIFICATIONS

Parameter	Dominar 400 BS VI	Parameter	Dominar 400 BS VI
Engine	4 Stroke, Single Cylinder	Fuel Tank Capacity	
Bore x Stroke	89 mm x 60 mm	Full	13 Liters (No Reserve)
Engine Displacement	373.27 cc	Dimensions	
Compression Ratio	12 : 1	Length	2156 mm
Idling Speed	1680 +/- 100 RPM	Width	836 mm
Max. Net Power	40 PS at 8800 RPM	Height	1112 mm
Max. Net Torque	35 Nm at 6500 RPM	Wheel base	1453 mm
Ignition System	DC	Ground Clearance	157 mm
FI System	BOSCH	Tyre Size Front	110/70-R17, Tubeless
Spark Plug	3 Nos.	Tyre Size Rear	150/60-R17, Tubeless
Spark Plug Gap	0.8 ~ 0.9 mm	Tyre Pressure	
Lubrication	Wet sump forced Lubrication	Front	2.04 Kg/cm ² (28.5 PSI)
Transmission	6 speed constant mesh	Rear (Solo)	2.25 Kg/cm ² (32 PSI)
Gear shifting Pattern	1 Down 5 Up	Rear (with pillion)	2.25 Kg/cm ² (32 PSI)
Engine Cooling	Liquid cooled	Electrical System	12 Volts DC
Starting Aid	Self	Battery	12V 8Ah VRLA
Front & Rear Brake	Disc	Head Lamp	LED

Parameter	Dominar 400 BS VI	Parameter	Dominar 400 BS VI
Position Lamp	LED	Horn	12V DC
Tail / Stop Lamp	LED	Vehicle Kerb Weight	187 kg.
Side Indicator	LED	Vehicle Gross Weight	337 kg.
Neutral Indicator	LED	<p>NOTES</p> <ul style="list-style-type: none"> • All dimensions are under UNLADEN condition. • Above information is subject to change without any notice. • This vehicle complies to BS VI standards. • AHO is government regulation. 	
Hi-Beam Indicator	LED		
Turn Signal Indicator	LED		
Speedometer Illumination	LCD		
Fuel Level Indicator	LCD Bar		
Malfunction Indicator	LED		
Low oil pressure Indicator	Alarm message		
Coolant Temp. Indicator	LED		
Low Battery Indicator	Alarm message		
Bajaj Logo	Display in DOT matrix		
REV Indicator	LED-Orange		
Service Reminder	Alarm message		
Side Stand Indicator	Alarm message		
ABS Indicator	LED		
Rear No. Plate Lamp	LED		

IDENTIFICATION DATA

The Frame and Engine serial numbers are used to register the motorcycle.

They are the unique alpha-numeric codes to identify your particular vehicle from others of the same model and type.

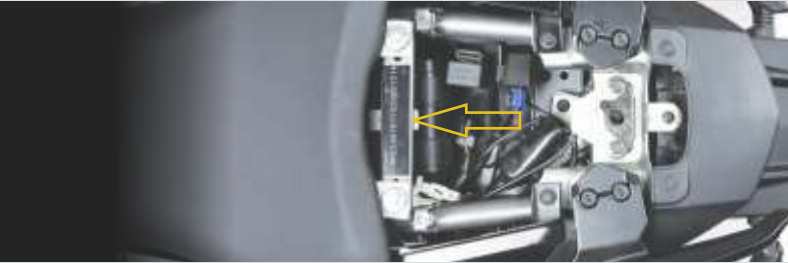

FRAME NUMBER LOCATION

On LH Side Crankcase Near Gear Change Lever (Alpha-Numeric - 11 Digits)

FRAME NUMBER LOCATION

On Seat Mounting Bracket (Alpha-Numeric - 17 Digits)

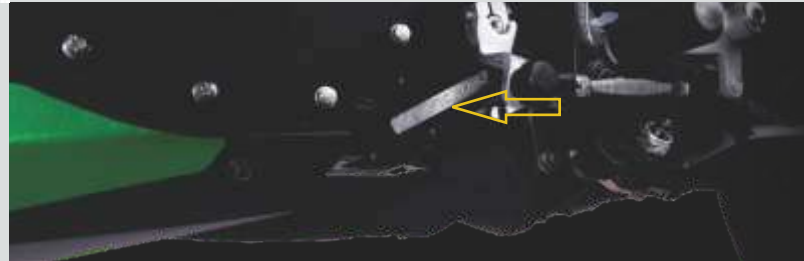

LOCATION OF PARTS

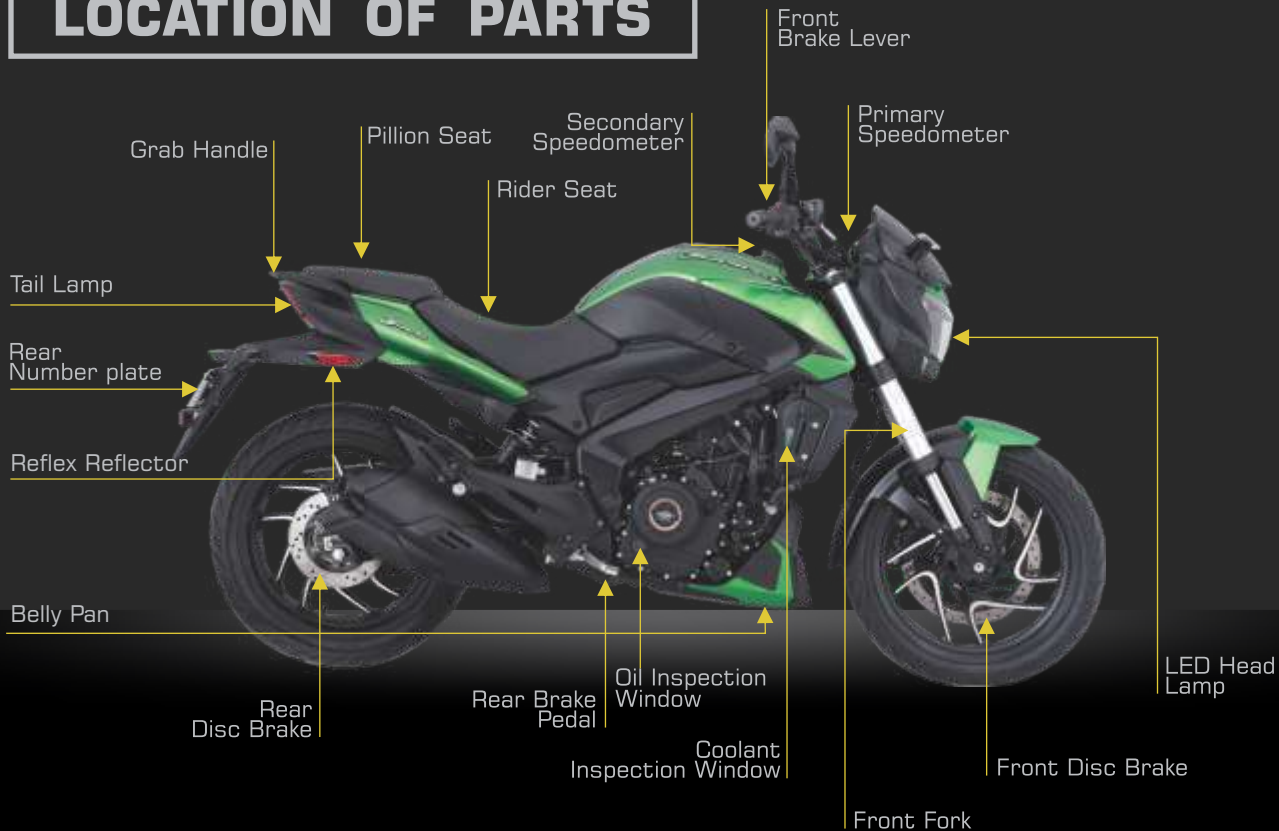

STEERING CUM IGNITION LOCK



STEERING CUM IGNITION LOCK

●	LOCK: Steering locked. Ignition OFF.
Ⓚ	OFF: Steering unlock. Ignition OFF.
Ⓛ	ON: Steering unlock. Ignition ON.

TO LOCK THE STEERING

To lock the steering, turn the handle bar to the left side. Turn the handle bar to the left or right. Push & Rotate the key to "LOCK" position & remove the key.

Steering locking on handle position left hand side only.

TO UNLOCK THE STEERING

Insert the key in steering cum ignition lock. Push & Rotate it clockwise to "OFF" or "ON" position.

KEY

A common key is used for 'Steering cum Ignition lock'. 'Fuel tank cap' & 'Rear Seat'

FUEL TANK CAP & SECONDARY SPEEDOMETER

Speedometer display will work when Ignition switch is in 'ON' position



FUEL TANK CAP

- To open the fuel tank cap, open the flap. Insert the key in the lock and turn it clockwise and lift fuel tank cap.
- To lock the 'Fuel Tank Cap' insert the key in the lock and turn it clockwise and press fuel tank cap. 'Click' sound ensures cap is fully locked.

PRECAUTION

Don't attach metallic 'Key chain' as it may damage paint of petrol tank cover.

- There is no fuel cock.
- Always maintain minimum 3 Liter Petrol in fuel tank.
- Do not use adulterated fuel or fuel additives as it will result in rusting & clogging of Injector, Fuel pump module & catalytic Converter.

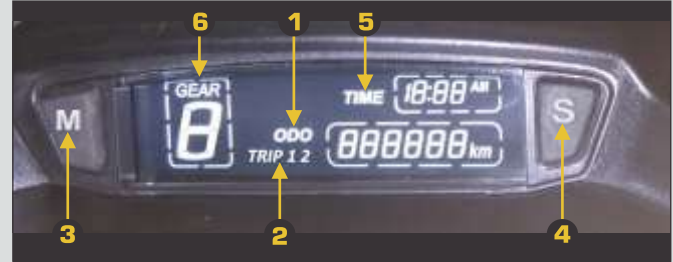

1. **Odometer** : The Odometer shows the total distance that the vehicle has covered. Odometer can not be reset to 'Zero'. Range 0 to 9.99.999 km.
2. **Trip Meter** : Trip 1 & Trip 2 shows the distance traveled since it was last reset to zero. Rolls over to zero after 999.9 km & continue updating.
3. **Mode Button**: Mode button used for changing the mode while selecting & setting Trip1, Trip2, ODD, INFO, Clock & Service reminder.
4. **Set Button**: Set button used for setting Clock & Service reminder. On pressing set button display in primary speedometer scrolls.
5. **Digital Clock**: It indicates time in HR: MM (AM/PM)
6. **Gear indication**: It will display gear position from 1 to 6. It will display 0 when vehicle is in neutral position.

PRIMARY SPEEDOMETER DETAILS

SPEEDOMETER DISPLAY WILL WORK WHEN IGNITION SWITCH IS IN 'ON' POSITION.

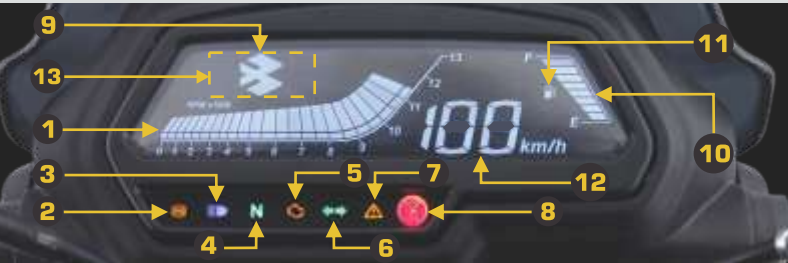

1. **Tachometer Dial:** It shows engine speed in RPM.
2. **ABS Indicator** (Yellow) (ABS): With Ignition switch ON the ABS indicator glows. When vehicle speed is more than 5 Km/hr, the ABS indicator goes OFF, if this indicator glows while vehicle is running, it means there is problem in ABS.
3. **Hi Beam Indicator:** When Headlight is 'ON' & Hi beam or 'PASS' is selected then Hi beam indicator will glow.
4. **Neutral Indicator:** When the transmission is in Neutral, Neutral indicator will glow - 'N' in primary speedometer & O will be displayed in secondary speedometer.
5. **Malfunction Indicator** (MFI): It glows whenever any abnormality is noticed in functioning of FI system components.
6. **Turn Signal Indicator** (LH & RH) : When Turn signal switch is pushed to Left or Right. Turn Signal Indicator - LH or RH will flash.

7. **Generic Alarm Indicator** (△): It remains continuously ON if alarm message = 1, it blinks if alarm messages are more than 1.
8. **Engine RPM Limit Indicator:** It reminds rider to drive in safe engine RPM.
Within initial 2000Kms running (RUNNING IN period)
 - RPM limit indicator blinks @ 6700 to 7000 RPM
 - RPM limit indicator continuously glows if RPM is >7000 km.Beyond 2000 kms running -
 - RPM limit indicator blinks @ 9200 to 9500 RPM
 - RPM limit indicator continuously glows if RPM is > 9500 km
9. **Bajaj Logo:** Bajaj logo flying 'B' glows with ignition 'ON'
10. **Fuel Level Indicator:** It shows approximate fuel level in fuel tank.
11. **Low Fuel Level Indicator :**
 Fuel bar = 1 - Bar 1 glows steady & low fuel symbol blinks
 Fuel bar = < 1 - Bar 1 & low fuel symbol both blinks Fuel bar = 2 - Low fuel symbol glows steady
12. **Speedometer:** Vehicle speed will be displayed in digital form in km/h.
13. Alarm / information messages will be displayed on Primary speedometer in Dot Matrix format.

TWIN CHANNEL ABS SYSTEM



Always maintain a safe distance between you and objects ahead. Vehicle speeds should always be reduced during extreme road conditions. The braking distance for motorcycle equipped with an anti-lock braking system may be longer than for those without it on rough road conditions. During these conditions the vehicle should be driven at reduced speeds.

When you apply Front brake / Rear brake under conditions which may lock the wheels, you feel a corresponding sensation (pulsation) in Front brake lever / Rear brake pedal. This is normal and it means your ABS is active.

Also it is recommended to use both front & rear brakes simultaneously.

Always slow down when cornering. The anti-lock brake system cannot prevent accidents resulting from excessive speeds.

If the ABS warning light is ON and stays ON, you may have a problem with the ABS. In this case, however, your regular brakes will work normally.

INSTRUCTIONS

- In case, Malfunction indicator & ABS indicator glows and alarm message of high coolant temperature, low battery & low engine oil pressure is displayed in speedometer, bring the vehicle to nearest BAL dealership for inspection / repair.
- Never drive by disconnecting wheel speed gear cable.

SPEEDOMETER FUNCTIONALITY DETAILS

Procedure to access information available in primary and secondary speedometer -

1. Function lines ODO, Trip1, Trip2, InFO are displayed in Secondary speedometer
2. Changeover from ODO → Trip1 → Trip2 → InFO can be done by pressing Mode button in Secondary Speedo

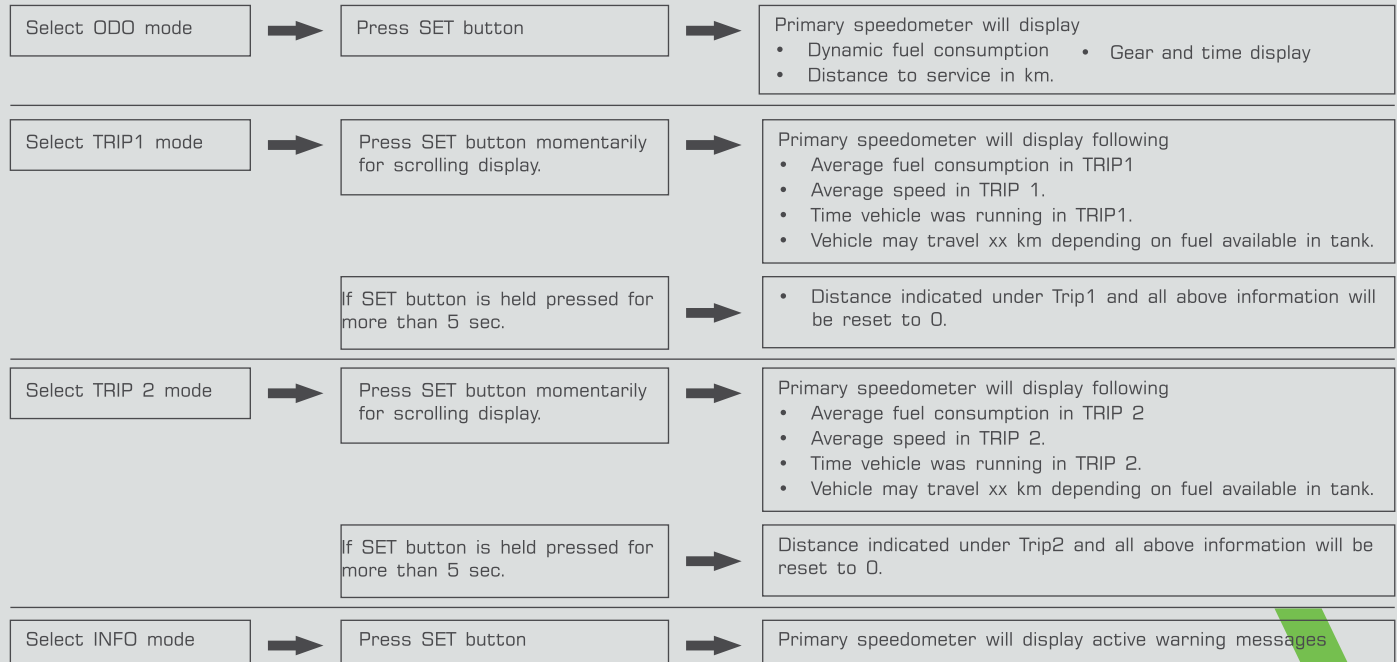

User can select any of the above screens and the screen at ignition OFF condition will be retained in next ignition ON cycle.

SPEEDOMETER FUNCTIONALITY DETAILS

Primary Speedometer:Dot matrix display functions-lines

Definition of terms-

Dynamic Fuel consumption	Instantaneous fuel consumption (km/L),updates after every 1.5 second according to the throttle input. Value changes for next 1.5 sec as per throttle input changes during that period and hence this is dynamic value changing frequently as per throttle input.
Average Fuel Consumption	Average fuel consumption (km/L) for a particular trip selected, updates after every 1 minute according to throttle input changes. It is a cumulative value of fuel consumption for a given trip once selected and the data from 0 km till next reset will be displayed based on cumulative average.
Active warning	Information about warning alarms displayed in DOT matrix
Average speed	Average speed (km/h) with which the vehicle was driven in a particular trip since last reset, a cumulative average from 0 km till trip reset.
Trip Time	Engine run time(minutes) in particular trip since last reset, sum of all engine run events from 0 km till trip reset.
Fuel range (Distance to Empty)	Approximate Distance(km) which can be covered in a particular trip till fuel tank becomes empty based on the average fuel consumption calculated and hence the value changes as per throttle input changes. The value indicated is to be treated as a reference or guidance to estimate probable distance covered with the rest fuel. (To be treated as an indication only)

Notes-

1. If TRIP 1/2 is reset-Trip 1/2 time, Average speed, average fuel consumption get reset to zero.
2. 24 hour clock and Trip1,2 (and associated values) get reset if permanent battery supply is removed.
3. Odometer value and units are retained if permanent battery supply is removed.

SPEEDOMETER FUNCTIONALITY DETAILS

Primary Speedometer : Dot matrix display functions-alarms

Message Display Area

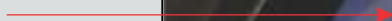

Information messages			
Information messages will be displayed according to selection of ODO / TRIP 1/ TRIP 2 /Info in secondary speedometer.			
ODO	TRIP 1	TRIP 2	Info
Dynamic fuel consumption	Average fuel consumption 1	Average fuel consumption 2	Active warning 1
	Average Speed 1	Average Speed 2	Active warning 2
Gear & Clock Indication	Trip Time 1	Trip Time 2	Active warning 3
	Fuel range	Fuel range	Active warning 4
Distance to Service			

SPEEDOMETER FUNCTIONALITY DETAILS

Primary Speedometer : Dot matrix display information (ODO)

Information messages in Odo Mode

Information messages will be displayed according to selection of ODO and pressing set button of secondary speedometer in below sequence -

ODO
(Seen in secondary speedo)



ODO

Dynamic fuel consumption
(Seen in dot matrix window of primary speedo)



Dynamic fuel consumption in kmpl

Gear Indication & Clock will also be displayed in primary speedometer:



Gear & Clock Indication.

NOTE : For Neutral gear position,
Primary speedometer shows "N" & Secondary speedometer shows "0".



Distance to Service
(Seen in dot matrix window of primary speedo)



Distance to Service

SPEEDOMETER FUNCTIONALITY DETAILS

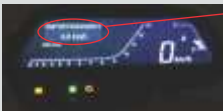
Primary Speedometer : Dot matrix display information (Trip1)

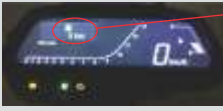





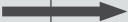

Information messages in Trip1 Mode	
Information messages will be displayed according to selection of TRIP 1 and pressing set button of secondary speedometer in below sequence -	
TRIP 1 (Seen in secondary speedo)	 <p>TRIP 1</p>
Average fuel consumption 1 (Seen in dot matrix window of primary speedo)	 <p>Average fuel consumption 1 in kmpl</p>
Average Speed 1 (Seen in dot matrix window of primary speedo)	 <p>Average Speed 1 in kmph</p>
Trip Time 1 (Seen in dot matrix window of primary speedo)	 <p>Trip Time 1</p>
Fuel range (Distance to Empty) (Seen in dot matrix window of primary speedo)	 <p>Fuel range (Distance to Empty)</p>

SPEEDOMETER FUNCTIONALITY DETAILS

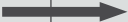
Primary Speedometer : Dot matrix display information (Trip2)

Information messages in Trip2 Mode

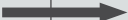
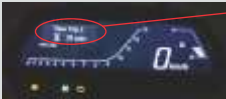
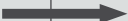
Information messages will be displayed according to selection of TRIP 2 and pressing set button of secondary speedometer in below sequence -

<p>TRIP 2 (Seen in secondary speedo)</p>		 <p>TRIP 2</p>
<p>Average fuel consumption 2 (Seen in dot matrix window of primary speedo)</p>		 <p>Average fuel consumption 2 in kmpl</p>
<p>Average Speed 2 (Seen in dot matrix window of primary speedo)</p>		 <p>Average Speed 2 in kmph</p>
<p>Trip Time 2 (Seen in dot matrix window of primary speedo)</p>		 <p>Trip Time 2</p>
<p>Fuel range (Distance to Empty) (Seen in dot matrix window of primary speedo)</p>		 <p>Fuel range (Distance to Empty)</p>

SPEEDOMETER FUNCTIONALITY DETAILS

Primary Speedometer : Dot matrix display warning messages (Info)

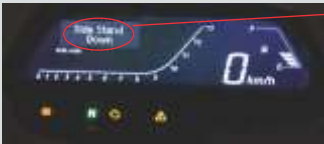
Warning messages in Info mode -	
Information messages will be displayed according to selection of Info and pressing set button of secondary speedometer. Generic alarm LED will be ON if warning message is triggered. If more than one messages, the generic alarm LED will start blinking at 1 Hz.	
<p>Info (Seen in secondary speedo)</p>	
<p>Active warning 1 (Seen in dot matrix window of primary speedo)</p>	
<p>Active warning 2</p>	<p>Refer list of warning messages</p>
<p>Active warning 3</p>	<p>Refer list of warning messages</p>

SPEEDOMETER FUNCTIONALITY DETAILS

Primary Speedometer : warning messages

Alarm Messages seen are as below -		
Priority	Parameter	Alarm message text Description
1	ECU CAN communication failure	ECU communication lost
2	ABS CAN communication failure	ABS communication lost
3	S Speedo CAN communication failure	Secondary speedo communication lost
4	Engine Kill ON	Engine Kill ON
5	Side stand Down	Side stand Down
6	Low Oil pressure	Low Oil pressure
7	High Coolant temperature	High Coolant temperature
8	Low Battery	Low Battery (Battery voltage 11.5VDC for more than 60 sec)
9	Low Fuel level / REFUEL	Low Fuel Level.(Fuel bars =2)
		REFUEL(Fuel bars=1)
10	Fuel level sensor failure	Fuel level sensor failure(open or short circuit in fuel level sensor)
11	Coolant Sensor failure	Coolant Sensor failure
12	Service Reminder (Icon)	Service Reminder with service icon

SECONDARY SPEEDOMETER SETTING



TRIP METER RESET

- Mode & Set push button is provided for selecting & resetting 'ODO/TRIP1/TRIP2'.

1.	Press mode push button for less than 2 sec.	Mode changes from 'ODO/TRIP1/TRIP2'
2.	Press set push button for more than 5 sec.	Selected 'TRIP1/TRIP2' will reset. Other TRIP mode will continue updating.

SERVICE REMINDER RESET (🔧)

'Wrench' symbol glows when ODO meter reading reached to set Kms.

This icon will glow at-

1st : 450 Kms 2nd : 4450 Kms
3rd : 9450 Kms 4th : 14450 Kms

& subsequently at each 5000 Kms.

NOTE

Bring the motorcycle at authorised BAL dealership for re-setting the service reminder icon.





CLOCK RESET

- Digital clock indicates time in HR & MM separated by colon ':'
- It is 12 hour clock.
- Initially icon ':' will be blinking
- Clock setting is possible in TRIP 1 mode only.

1.	Press mode push button for less than 2 sec.	TRIP1 Mode selected
2.	Press mode & set push button together for more than 2 sec.	Icon ':' stops blinking Digits starts blinking
3.	Press mode button for less than 1 sec.	Hour digits will increase.
4.	Press set button for less than 1 sec.	Minutes digits will increase.
5.	Press mode & set button together for more than 2 sec.	Set value will be saved Exit clock setting mode Digits stop blinking icon ':' start blinking
6.	Clock set mode is selected & no editing is carried out for more than 5 sec.	Auto exit without saving set value. If engine / vehicle rpm is given then system will exit from clock set mode without saving set value.

CONTROL SWITCH RH

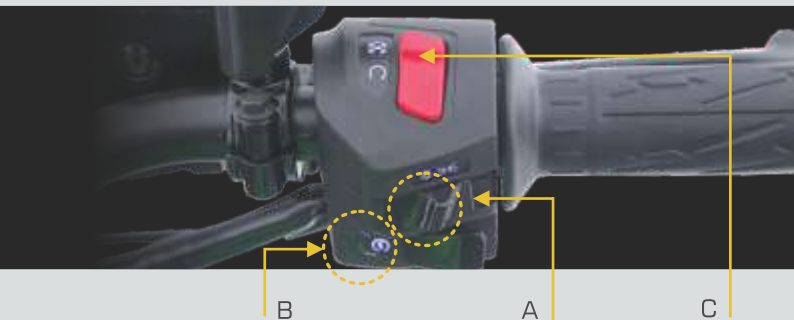

A. HEAD LIGHT SWITCH

It has 2 positions.

☰	Pilot Mode
☀	Headlight Mode

B. STARTER BUTTON

Starter button operates the electric starter. It is recommended to start the engine with the transmission in neutral.

Vehicle in Gear - Press clutch lever & operate starter button to start the engine.

C. ENGINE KILL SWITCH













The engine kill switch is used for switching ON & OFF the engine.

⊗	Engine OFF
⊙	Engine ON

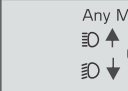
AUTOMATIC HEADLAMP & LIGHTS OPERATION

NOTE

- Your vehicle has a safety feature which turns ON the headlamp automatically, once the engine is started. This provides better visibility to other road users.
- While riding, low beam or hi beam mode can be switched ON by operating the low/hi beam selector switch, keeping the light switch in head light mode.

IGNITION SWITCH	ENGINE	LIGHT SWITCH	LOW/HI BEAM SELECTOR SWITCH	THE FOLLOWING LIGHTS WILL GLOW	EFFECT IF PASS SWITCH IS PRESSED
 ON ()	OFF	 Any Position 	 Any Mode 	Front Position lamp, Tail Lamp, Rear Number Plate Lamp, Control Switch Illumination, Both speedometer illumination	Headlamp Hi beam & Low beam will glow.
	Started	 Toward right (Pilot mode)	 Any Mode 	Front Position lamp, Tail Lamp, Rear Number Plate Lamp, Control Switch Illumination, Both speedometer illumination, Headlamp Hi beam	Headlamp Low beam will also glow.
		 Toward Left (Headlight mode)	 Low beam mode ()	Front Position lamp, Tail Lamp, Rear Number Plate Lamp, Control Switch Illumination, Both speedometer illumination, Headlamp low beam	Headlamp Hi beam will also glow.
			 Hi beam mode ()	Front Position lamp, Tail Lamp, Rear Number Plate Lamp, Control Switch Illumination, Both speedometer illumination, Headlamp Hi beam & low beam	No effect

CONTROL SWITCH LH

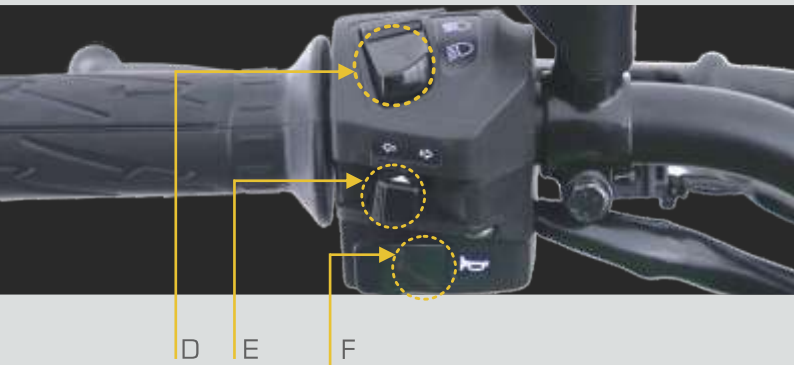

LEFT HANDLE BAR SWITCHES

D. HIGH / LOW BEAM SWITCH

When headlight is ON, High or Low beam can be selected with this switch. Hi beam indicator light located on Speedo console will glow when high beam is selected.

☰ : High Beam ☱ : Low beam

E. TURN SIGNAL SWITCH

When the turn signal knob is pushed to Left (↶) or Right (↷) respective indicator will start blinking. To stop blinking push the knob in & release.

F. HORN BUTTON

(🔊) Press button for sounding horn.

G.PASS SWITCH

Press the switch to put on Hi Beam of head light. It is used to give signal to vehicles coming from opposite side while overtaking.



REMOVAL OF PILLION & RIDER SEAT / TOOL KIT



REMOVAL OF PILLION SEAT

- Insert Key into lock (A)
- Turn the key clock wise.
- Lift rear end of 'Rear seat'
- Pull 'Pillion seat' backward side.
- Take out 'Pillion seat'.



REMOVAL OF RIDER SEAT

- First remove 'Pillion seat'.
- Remove 'Rider seat' mounting bolts (B).
- Pull backward rear end of 'Rider seat'.
- Take out 'Rider seat'.



TOOL KIT LOCATION

- Tool kit fitment location is provided below pillion seat assembly.
- Tool kit to be clamped on Pillion seat assembly by rubber strap.

FIRST AID KIT LOCATION

- It is located on LH side of Seat Cowl below the 'Pillion seat'.

FITMENT OF RIDER & PILLION SEAT

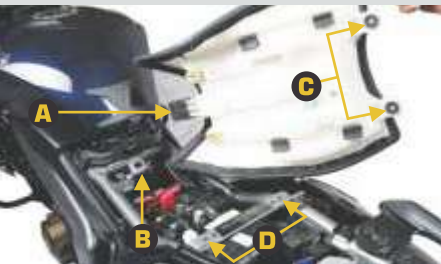

FITMENT OF 'RIDER SEAT'

- Match the bracket of 'Rider seat' (A) with slot (B), Ensure availability of rubber damper of seat center.
- Slide 'Rider seat' toward petrol tank.
- Match 'Rider seat' rear brackets (C) with the holes (D) provided on chassis & Tighten the bolts (E).

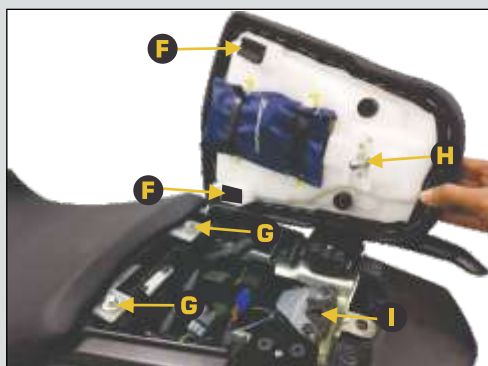

FITMENT OF 'PILLION SEAT'

- First make sure 'Rider seat' is fitted properly.
- Insure 'Tool kit' is located properly on pillion seat
- Place 'Pillion seat' on fitment location.
- Match the bracket of 'Pillion seat' (F) with Hook (G).
- Slide pillion seat towards rider seat.
- Insert lock rod (H) of seat into seat lock (I).
- Press rear portion of seat from top.

DAILY SAFETY CHECKS

Before riding motorcycle be sure to check following items. Please give proper importance to these checks and perform all of them before riding motorcycle.

If any irregularities are found during these checks, refer to the Maintenance chapter & see your dealer for the action required to return the motorcycle to a safe operating condition.



Warning: Failure to perform these checks every day before you ride may result in serious damage or severe accident.

- Enough fuel level for planned distance of journey. No fuel leakage in fuel lines.
- Engine oil level (between upper and lower level mark) at vehicle upright position on level surface.
- Throttle cable play of 3 mm. Smooth operation and positive return to closed position.
- Brake Fluid level above MIN mark provided on reservoir. (Both front and rear)

- Drive Chain slack of 20 ~ 30 mm adequately lubricated by OKS spray. This is available with BAL dealer for sale.
- Function of all lights & horn
- Clutch lever play - 3 mm
- Check Coolant level between MIN and MAX mark in coolant reservoir tank at vehicle upright position on level surface.
- Smooth steering movement without restriction.
- Side stand return to It's fully up position.
- Correct inflation pressure in both tyres
Adequate tyre tread depth - no cracks / cuts.
- Correct rear viewing span adjustment of mirror.
- Cleaning cloth not to be kept in vicinity of high temperature zone e.g. Radiator, engine, silencer assy, starter motor etc.
- Cleaning cloth to be strapped along with tool kit under seat assy.

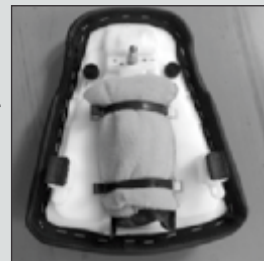

HOW TO RIDE YOUR BIKE



1. STARTING THE ENGINE

- Turn ignition switch key to 'P' position.
- Put kill switch in 'Q' position.
- Confirm that transmission is in neutral / press the clutch lever if transmission is in gear.
- Keep throttle closed & press starter button,
- Release starter button as soon as engine starts.



Caution: Do not operate the starter continuously for more than 5 seconds otherwise battery would get discharged.

Wait 15 sec. between each operation of the starter which will facilitate battery to recover.

NOTE

The motorcycle is equipped with a Clutch switch. This switch ensures that engine does not start if the transmission is in gear. However, the engine can be started in any gear if the clutch lever is pressed.

NOTE

In case of battery discharged condition, vehicle will start by push start.

2. SHIFTING GEARS

- Close throttle & depress the clutch lever.
- Shift into next higher or lower gear.
- Open the throttle and release the clutch lever slowly and simultaneously.

3. MOVING OFF

- Check that side stand is up.
- Depress the clutch lever.
- Shift into 1st gear.
- Open the throttle and release the clutch lever slowly and simultaneously.
- As the clutch starts to engage, open the throttle a little more, giving the engine just enough rpm to keep it from stalling.

RECOMMENDED SPEED FOR SHIFTING DOWN

From 6 th to 5 th Gear	71 km/h
From 5 th to 4 th Gear	59 km/h
From 4 th to 3 rd Gear	48 km/h
From 3 rd to 2 nd Gear	37 km/h
From 2 nd to 1 st Gear	22 km/h

4. BRAKING

- Close the throttle completely, leaving the clutch engaged (except where shifting gears) so that the engine braking will help slow down the motorcycle.
- Shift down one gear at a time so that you are in Neutral when you come to a complete stop.
- When stopping, always apply both brakes at the same time.



Warning : When shifting down to lower gear, do not shift at such high speed that engine rpm jumps excessively. This may cause engine damage, & rear wheel may skid. Downshifting should be done at recommended speeds as shown in table above.

5. STOPPING THE VEHICLE

- Close the throttle completely.
- Shift the transmission into neutral.
- Bring the vehicle to complete stop.
- Turn the ignition switch off.

6. RUNNING IN

Proper running-in is important for the better life & trouble free performance of the vehicle.

- During first 2000 kms running-in period do not exceed following speed limits.

Kms	1st	2nd	3rd	4th	5th	6th
0 - 1000	10	20	30	40	50	60
1000 - 2000	20	30	40	50	60	70

- Always keep the speed below the limits mentioned in the table.
- Do not race the engine excessively.
- Do not start moving or race the engine immediately after starting. Run the engine for a minute at idle speed to give the oil a chance to workup into the engine.

7. VEHICLE PARKING

- This vehicle do not have main stand.
- Support the motorcycle on a firm level surface with the side stand.
- Lock the steering on LHS.



CAUTION

1. Do not park on a soft or steeply inclined surface as the motorcycle may fall over.
2. Always ensure side stand is UP while starting off.
Ignition will be cut off if vehicle is attempted to be driven in side stand DOWN condition and 'side stand down' message will be displayed in primary speedometer.

3. If engine coolant temperature crosses 110°C, 'Coolant Temperature high' alarm message will be displayed on primary speedometer indicating engine is overheated. **If vehicle is further driven in such a condition coolant temperature will increases up to 115°C & ECU will not allow engine to run above 4500 PRM.**

4. This vehicle has new 'A & S clutch'(Assist & sleeper).

Due to this, very little force is required for clutch lever operation. you won't feel jerks while sudden down shifting.

Slight pulsation is felt at clutch lever. This is normal & indicates 'A & S clutch' is working well.

5. Power output of headlight is only 20W max & hence continuously glowing headlight will not damage / reduce life of battery.

- Do Not rev engine in standstill condition.
- Don't use adulterated fuel or fuel additives as it will result in rusting & clogging of engine parts.

GOOD RIDING HABITS

- Always fill 91 octane petrol at reputed petrol pumps for optimum performance of bike.
- Always maintain minimum 3 liters petrol in petrol tank for smooth functioning of fuel pump.
- Always maintain recommended air pressure in both the tyres.
- Always maintain engine oil / coolant level between MIN & MAX mark at vehicle upright position on level surface.
- Avoid harsh braking.
- Always apply both brakes simultaneously.
- Always ensure brake fluid level in both front & rear reservoir is above MIN mark.
- Change the gear judiciously according to the speed and load requirement.
- Don't overload the vehicle above the specified payload.
- Use the accelerator judiciously.



- Cut off the engine if you want to stop for more than two minutes.
- Press clutch lever fully while shifting gears.
- Always ensure battery is fully charged.

HOW TO CHECK MILEAGE (FUEL EFFICIENCY)

- Best way to calculate mileage is by following the full tank to full tank method.
- Fill way tank full up to small mouth (brim).
 - Run the bike for say 100 km.
 - Fill the tank full again in same fuel filling station, probably with same fuel dispenser.
 - Divide kilometer run / fuel quantity filled.

SAFE RIDING TIPS

Safe Riding Tips

- Always wear Helmet while driving or riding. Your helmet should conform to appropriate Indian standards.
- Read thoroughly the instructions given in this manual and follow them carefully.
- Avoid unnecessary accessories for the safety of both rider and other motorists.
- Get familiar and follow traffic rules & regulations in your states as well as general traffic signs.
- Familiarise yourself well with starting, acceleration and braking of the vehicle.
- When applying the brakes, use both front & rear brakes simultaneously. Applying only one brake may cause the vehicle to lose control.
- Riding at proper speed and avoiding unnecessary acceleration and braking are important not only for safety and low fuel consumption, but also for longer life of the vehicle.
- During monsoon, drive the vehicle more cautiously. Remember vehicle skid more easily during light showers.



- It is suggested to customer to take appropriate care in area of heavy monsoon or high rainfall area. The appropriate surface preventive coat to avoid rusting / poor surface finish on account of adverse atmospheric conditions.
- Always carry vehicle registration & insurance papers, and a valid driving licence with you.

General Maintenance Tips :

- Vehicle cleaning to be done with soft & clean wet cloth to avoid scratches on painted parts.
- Clean & lubricate all the important parts as detailed in a periodic maintenance chart.
- Do not apply direct water jet on painted, electrical / electronic parts.
- Do not obstruct engine cooling by adding mud protection sheet from front
- Drive cautiously. Start early & reach your destination safely.
- Avoid driving on loose sand or stones where vehicle is likely to skid.
- Properly wrap-up loose clothes while driving or riding to avoid entangling in wheel or other objects on road.
- Always concentrate on riding for safety.

ENGINE OIL

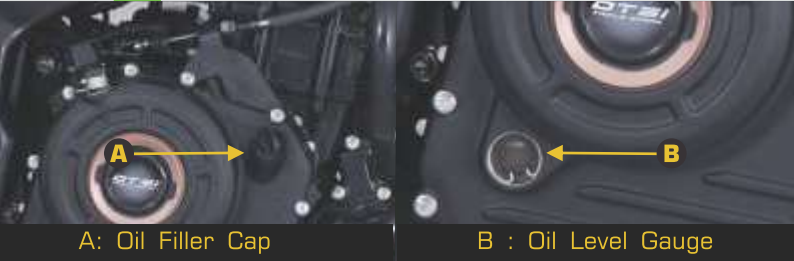

LEVEL CHECKING

- Check engine oil level every day at vehicle upright position on level surface (at engine cold condition).
- Check oil level through oil level gauge 'B'.
- Always maintain engine oil level between upper (C) and lower (D) mark provided on Cover RH. Top up with specified grade of oil if the oil level is below lower level mark.

ENGINE OIL CAPACITY

- Refill at servicing: 1700 ml.
- During engine overhaul: 1950 ml.



CAUTION:

It is most important to adhere to recommended grade & frequency of oil change for the purpose of long life of critical engine components. For details refer periodic maintenance chart.

RECOMMENDED ENGINE OIL:

Always insist on Bajaj Genuine Engine Oil for optimum engine performance & warranty benefits. It is a specially formulated oil for Dominar 400.

Model	Recommended Engine oil	Grade
Dominar 400	Bajaj DTS-i 10000 10W50 BS6 Compliant	JASO MA2 API SN, Fully Synthetic



- **For all BS VI Vehicles, BS VI compliant engine oil is to be used only. Use of BS VI engine oil will give prolonged life of catalytic convertor.**
- **Engine oil replacement frequency: 1st service & then every 10,000 Km.**
- **Engine oil level top-up frequency: Every 5000 km.**

TUBELESS TYRE & TYRE PRESSURE



TUBELESS TYRE

The main advantage of tubeless tyres is in case of puncture the rate of air leak is very slow, hence customer can easily drive the vehicle upto nearest puncture repair shop for removing puncture.

NOTE

Incase the motorcycle is fitted with imported tyres, compliance to respective Indian standard & central motor vehicle rules has been ensured.

WHEEL PUNCTURE

- Visit nearest known tubeless tyre repair shop to remove puncture.
- Remove puncture by Filler or Plug method only.
- Do not use patch method to remove puncture of tubeless tyre.

CAUTION

Tubeless tyres are fitted in this motorcycle. The walls of the tyres in contact with the wheel rim should not be damaged in any way during fitment / removal of tyre. The tyre side walls in contact with wheel rim seals air.

- Tyre warranty is settled by tyre manufacturer.
- Decision is taken based on tyre wear and running of vehicle.
- BAL settles tyre warranty only for imported tyres.

TYRE PRESSURE

Keep appropriate tyre pressure as mentioned below to increase life of the tyre & for better fuel consumption.

Dominar 400	Front	28.5 PSI
	Rear (Solo)	32 PSI
	Rear (with Pillion)	32 PSI

BATTERY



12V - 8 AH VRLA

- Battery is located below Rider seat.

BATTERY FEATURES

- No topping-up is required
- Reduced self discharge, Enhance safety.
- No vent tube open to atmosphere hence no discharge of electrolyte through vent tube.

CAUTION

Do not drive / run vehicle in battery disconnected condition. It may lead to damage of electrical / electronic components.

- Environment care must be taken to dispose off the used battery.
- It is always recommended to hand over the same to the Authorised battery / Bajaj dealer for proper disposal of the same.
- When 'Low battery icon' pop-up in speedometer display, it is advised to reach Bajaj dealer & get it charged immediately.
- Warranty for battery is 18 months from the date of purchase of vehicle.

HOW TO KEEP BATTERY HEALTHY?

- Switch 'Off' ignition when engine is not running.
- Get battery checked/ charged during periodic services.
- Do not press starter button for more than 5 sec. After 3 successive cranking, wait for 15-20 sec. for battery to recover.
- Do not add extra electrical accessories such as - Remote, Bigger Horn, Musical brake light etc. This will reduce life of battery & may damage ECU.
- Disconnect battery +ve & -ve wires if vehicle is to be stored for more than 2 weeks. This avoids self discharge.

ENGINE COOLING SYSTEM

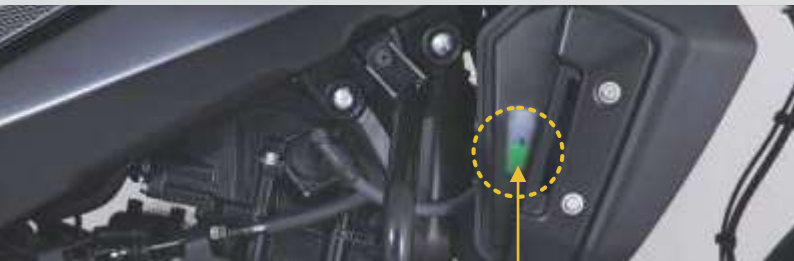

Coolant Expansion Tank

- Coolant is provided for cooling of engine.
- Water pump in the engine circulates the coolant in cooling system.
- The pressure resulting from the warming of the cooling system is regulated by a valve in radiator cap (A).
- Heat expansion causes excess coolant to flow into expansion tank.
- When the coolant temperature drops, this surplus coolant is sucked back into the cooling system.
- Cooling fan is provided for cooling of coolant circulated through radiator fins.

NOTE

Fan will start at temp 95.3°C and stops at 90°C . This is normal condition & it indicates cooling system functioning well.

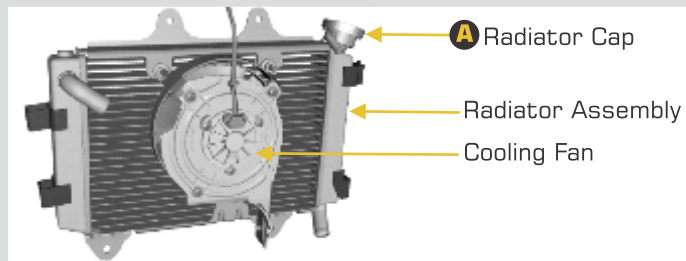

WARNING:

During operation, the coolant gets very hot & is under pressure. In case of scalding, rinse immediately with lukewarm water. Do not remove radiator cap, radiator hose or other cooling system components when the engine is hot. Allow the engine & cooling system to cool down.

COOLANT

⚠ WARNING:

Coolant is poisonous and causes health hazard.

Avoid contact between coolant & skin, eyes and clothing. If it gets into your eyes, rinse immediately with water and contact a doctor.

Wash affected skin areas immediately with soap and water. If coolant is swallowed, contact a doctor immediately. Change clothes that have come in contact with coolant. Keep coolant out of the reach of children.

COOLANT SPECIFICATIONS

Use antifreeze ready to use "Bajaj Koolex" coolant only.

Total coolant quantity : 1000 ml.
(750~780 ml in radiator &
220~230 ml expansion tank).

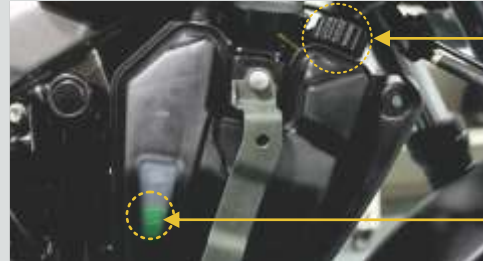

Expansion
Tank Cap (A)

Coolant Level
Inspection
Window

COOLANT TOP UP

- Park vehicle at upright position on level surface. Remove 2 nos screws to access expansion tank cap.
- Check coolant level in engine cold condition only.
- Ensure coolant level is between Min & Max mark.
- Always top up coolant through expansion tank cap (A).
- Always replace coolant with "Bajaj Koolex" coolant only.
- Use nitrile rubber hand gloves while draining & topping up coolant.
- Do not top up coolant through radiator cap.

PERIODIC MAINTENANCE INFORMATION

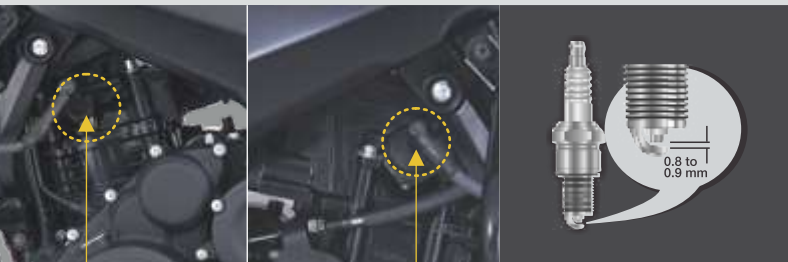

A

B

SPARK PLUG

- Remove spark plugs by using plug spanner.
- Clean the spark plugs at 10000 Kms.
- Adjust the gaps if incorrect by bending outer electrode carefully.

Spark Plug Gap: 0.8 to 0.9 mm.

Spark Plug

(2 Nos.) : CHAMPION (PRG6HCC)
(LH 'A' + RH 'B')

(1 No.) : CHAMPION (RER6YCA)
(Center 'C')

DRIVE CHAIN SLACKNESS

- Chain slackness will have to be adjusted whenever required.
- Std. Chain slackness 20 ~ 30 mm.
- Marking on chain adjusters should be identically positioned on both sides.



- Ensure application of 9 to 11 Kgf.m torque to rear axle nut.



METHOD OF O-RING CHAIN LUBRICATION

- Put vehicle on side stand & tilt the vehicle to make rear wheel free. Clean the chain by using lint free cloth (If excessive mud / slush found approach Bajaj dealer for proper cleaning).
- Shake the can vigorously by holding vertically upright till the noise of steel ball inside heard uniformly.
- Hold spray can at the back of rear sprocket with extension tube nose at 5~10 cm.
- Rotate the wheel in reverse direction & spray the lube on middle portion of the chain up to full length of the chain.

DRIVE CHAIN CLEANING

Drive Chain (O-ring type)

Drive chain must be cleaned & lubricated as per periodic maintenance schedule.

- 'O' rings must always be kept wet for best performance hence lubricate every 500 Km.
- **O-ring chain lubrication can easily be done by owners using Bajaj 'Chain Lube Spray Can' available with Bajaj dealers for sale.**



BRAKE FLUID/HEADLAMP CARE



Rear Brake
Fluid Reservoir

Front Brake
Fluid Reservoir

FRONT & REAR BRAKE FLUID LEVEL

- Front brake fluid reservoir is located on RH side of Handle bar.
- Rear brake fluid reservoir is located behind RH Step holder.
- To check the brake fluid level, park the vehicle at upright position on level surface. with handle bar in straight ahead condition.
- Always ensure that brake fluid level is above 'MIN' mark given on inspection Window.
- In case of level drop, use only DOT-4 brake fluid (from sealed container) for top up & replacement.

HEADLAMP CARE

Condensation inside headlamp is a natural phenomenon.

Condensation occurs when atmospheric air containing water vapor or humidity enters the headlamp through the vents due to temperature difference. A thin film of fog can form on the inside surface of the headlamp lens. The thin fog will clear and exit through the vents during normal operating condition.

Condensation & fogging of headlamp lens may happen during rain or after washing.

Moisture condensation inside the headlamp lens will disappear gradually by switching ON the headlamp in high beam and driving the vehicle at 30 to 40 Kmph speed for about 15 minutes.

Time for evaporation will vary depending on the humidity of the ambient air.

NOTE

If fog inside the headlamp does not evaporate bring the vehicle to Bajaj Authorised Dealer for inspection.

USAGE OF 'LUGGAGE STRAPS' WITH BUNGEE CORD

USAGE OF 'LUGGAGE STRAPS' WITH BUNGEE CORD

If provided, luggage straps below pillion seat, then these straps to be used for bungee cords for clamping luggage on vehicle.

Procedure to use luggage straps :

- Open Pillion seat & take out front and rear luggage straps.(refer photographs A)
- Re-fit pillion seat on its position (B).
- Now you can use luggage straps to hook 'Bungee cord' (not supplied with vehicle) for clamping luggage on vehicle ©. (Maximum allowed luggage load is 15 Kg)

Caution :

Luggage straps can be used only for strapping a luggage bag or similar as shown in the pictures (C & D). The total weight of the bag and its contents shall not exceed 15Kgs.

While using the strap the user shall ensure that necessary precautions are taken in order to ensure that the:

- Luggage / luggage bag is well balanced on the seat and securely tied with help of suitable cord / rope which are strong enough for the purpose.
- Parts of the Vehicle are not damaged due to in appropriate luggage or due to the additional hardware used for securing same.

It is not recommended to use these straps to carry any articles which may damage the vehicle parts or affect the stability of the bike while driving

Warranty is not applicable for any damages arising due to luggage over weight, sharp edges.

When luggage straps are not in use follow below steps.

1. Front straps to be folded with velcro on strap ends & Insert the folded straps under rider seat
2. Rear straps to be folded neatly to approach the hooks & insert straps in hooks.

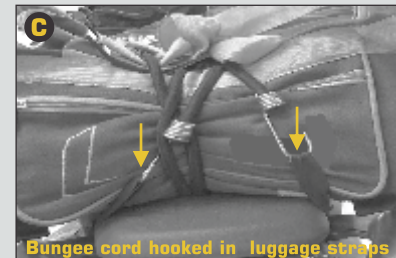
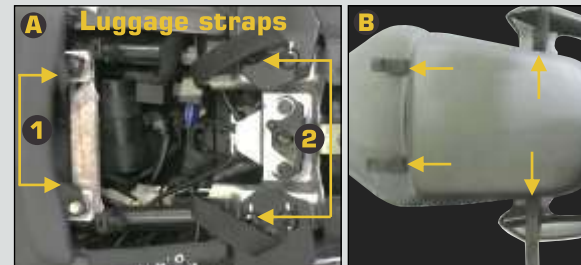

FREE SERVICE GUIDELINES

VEHICLE IS TO BE SERVICED / REPAIRED AT BAL DEALERSHIP ONLY

INSTRUCTION TO AVAIL FREE SERVICE THROUGH DIGITIZED FREE SERVICE COUPON

Please follow following procedure:

- Please provide your mobile number to Dealer at the time of buying of new Bajaj Vehicle.
- In case of change in mobile number, please update to Dealer / ASD.
- You will receive the Customer ID through SMS at the time of buying of new vehicle.
- Please note the Customer ID in Owner's Manual for your reference.
- During Free Service, please provide your Customer ID to Dealer / ASD workshop.
- When you are at Dealership / ASD workshop for Free Service, you will receive the 'Unique Coupon Number' (UCN) through SMS in your mobile.
- Please inform the UCN to Dealer / ASD at the time of Free Service.

(ASD-Authorised Service Dealer)

CUSTOMER ID:

Periodic Service Criteria			
Service	Days	Kms	whichever occurs earlier
1st Free Service	30~45	500~750	
2nd Free Service	240	4500~5000	
3rd Free Service	360	9500~10000	
Subsequent Paid services	120 Days from last Service	Every 5000 Km after previous service	

Availing all Free / Paid Services, replacing mandatory periodic parts & engine oil will entitle warranty eligibility.

PERIODIC MAINTENANCE & LUBRICATION CHART

Sr. No.	Activities / Check points	Recommended frequency - Service interval & Kms							
		Servicing	1st (Free)	2nd (Free)	3rd	4th	5th	6th	7th
		KMS	500 750	4500 5000	9500 10000	14500 15000	19500 20000	24500 25000	29500 30000
1.	Servicing with water wash	✓	✓	✓	✓	✓	✓	✓	✓
2.	Engine oil (Bajaj DTSI 10000 oil)	Top-up,R	R	Top-up	R	Top-up	R	Top-up	R
3.	Engine oil Filter	R	R		R		R		R
4.	Engine Oil strainer & Evacuation oil strainer	CL	CL		CL		CL		CL
5.	Air cleaner element** & air filter cover 'O' ring. Drain tube cleaning.	R					R		
6.	in-line fuel filter	R				R			R
7.	Inline fuel filter nylon hoses with quick connector	C,R					C,R		
8.	Spark plug clean & check gap	CL,A, R			CL,A		CL,A		R
9.	Valve tappet clearance	C, A				C, A			C, A
10.	Throttle body rubber duct (Sleeve) for hard resulting in loose fitment.	C,R				C,R	C,R	C,R	C,R
11.	Engine breather tube for cracks.	C,R			C,R	C,R	C,R	C,R	C,R
12.	EVAP system Hoses- check for cracks	C,R		C,R	C,R	C,R	C,R	C,R	C,R
13.	Radiator fins	C,R		C,R	C,R	C,R	C,R	C,R	C,R

PERIODIC MAINTENANCE & LUBRICATION CHART

Recommended frequency - Service interval & Kms									Remarks
8th	9th	10th	11th	12th	13th	14th	15th	16th	
34500 35000	39500 40000	44500 45000	49500 50000	54500 55000	59500 60000	64500 65000	69500 70000	74500 75000	
✓	✓	✓	✓	✓	✓	✓	✓	✓	Ensure to prevent water entry in Petrol tank, Silencer & electrical parts. Use caustic free detergent for washing.
Top-up	R	Top-up	R	Top-up	R	Top-up	R	Top-up	Use BGO 10W50. Oil level window cleaning at every 10000 kms by petrol spray & nylon brush
	R		R		R		R		Replace oil filter in 1st service & at every 10000 Kms.
	CL		CL		CL		CL		Oil strainer cleaning at the time of oil change.
	R				R				Replace viscous filter at every 20,000 Kms.
		R			R			R	Replace at every 15000 Kms.
	C,R				C,R				Replace if required
	CL,A		CL,A		R		CL,A		Replace at every 30000 kms
		C, A			C, A			C, A	
C,R	C,R	C,R	C,R	C,R	C,R	C,R	C,R	C,R	Replace if required
C,R	C,R	C,R	C,R	C,R	C,R	C,R	C,R	C,R	Replace if required
C,R	C,R	C,R	C,R	C,R	C,R	C,R	C,R	C,R	Drain EVAP "Y" connection drain tube. Replace if found cut / damaged
C,R	C,R	C,R	C,R	C,R	C,R	C,R	C,R	C,R	If found damaged, replace it

PERIODIC MAINTENANCE & LUBRICATION CHART

Sr. No.	Activities / Check points	Recommended frequency - Service interval & Kms							
		Servicing	1st (Free)	2nd (Free)	3rd	4th	5th	6th	7th
		KMS	500 750	4500 5000	9500 10000	14500 15000	19500 20000	24500 25000	29500 30000
14.	Check Coolant level in expansion tank / Hose clamp adjustment	C,A	C,A	C,A	C,A	C,A	C,A	C,A	C,A
15.	Coolant & Radiator hoses	Replacement at every 30000 Kms or 3 year (whichever occurs earlier)							
16.	Engine foundation silent bushes for cracks	C,R			C,R		C,R		C,R
17.	Silencer drain hole cleaning	CL			CL	CL	CL	CL	CL
18.	Water Pump seals	R							
19.	Wiring harness connections, routine & Conduit / PVC sleeve inspection.	C,A,T	C,A,T	C,A,T	C,A,T	C,A,T	C,A,T	C,A,T	C,A,T
20.	Battery, connections & health by load tester. +ve terminal cap fitment.	C,A,L,T	C,A,L,T	C,A,L,T	C,A,L,T	C,A,L,T	C,A,L,T	C,A,L,T	C,A,L,T
21.	Ignition switch contacts cleaning	CL,L			CL,L	CL,L	CL,L	CL,L	CL,L
22.	HT coil connections (Primary and Secondary)	C,T		C,T	C,T	C,T	C,T	C,T	C,T
23.	Starter motor & starter relay connections	C,T		C,T	C,T	C,T	C,T	C,T	C,T
24.	Oil pressure indicator check on console post ignition ON.	C,R	C,R	C,R	C,R	C,R	C,R	C,R	C,R
25.	Check fault code, Clear fault history, Update latest hex file if applicable	C	C	C	C	C	C	C	C
26.	sealed Drive chain wear**- Clean, Lubricate & adjust. Replace if required	CL,L,A	CL,L,A	CL,L,A	CL,L,A	CL,L,A	CL,L,A	CL,L,A	CL,L,A

PERIODIC MAINTENANCE & LUBRICATION CHART

Recommended frequency - Service interval & Kms									Remarks
8th	9th	10th	11th	12th	13th	14th	15th	16th	
34500 35000	39500 40000	44500 45000	49500 50000	54500 55000	59500 60000	64500 65000	69500 70000	74500 75000	
C,A	C,A	C,A	C,A	C,A	C,A	C,A	C,A	C,A	Coolant top up if required. Use BAJAJ Koolex coolant only
Replacement at every 30000 Kms or 3 year (whichever occurs earlier)									
	C,R		C,R		C,R		C,R		Replace if required
CL	CL	CL	CL	CL	CL	CL	CL	CL	
	R								
C,A,T	C,A,T	C,A,T	C,A,T	C,A,T	C,A,T	C,A,T	C,A,T	C,A,T	Damaged conduit / PVC sleeves protection by applying electrical tape film
C,A,L,T	C,A,L,T	C,A,L,T	C,A,L,T	C,A,L,T	C,A,L,T	C,A,L,T	C,A,L,T	C,A,L,T	Apply petroleum jelly on battery terminals. Use midtronics battery tester
CL,L	CL,L	CL,L	CL,L	CL,L	CL,L	CL,L	CL,L	CL,L	Use recommended WD40 spray
C,T	C,T	C,T	C,T	C,T	C,T	C,T	C,T	C,T	
C,T	C,T	C,T	C,T	C,T	C,T	C,T	C,T	C,T	
C,R	C,R	C,R	C,R	C,R	C,R	C,R	C,R	C,R	Icon should disappear post engine ON. After 4000 rpm, no icon should be displayed.
C	C	C	C	C	C	C	C	C	
CL,L,A	CL,L,A	CL,L,A	CL,L,A	CL,L,A	CL,L,A	CL,L,A	CL,L,A	CL,L,A	During 1st free service use OKS spray for chain cleaning without removing chain from vehicle. •During other services clean chain with Diesel+SAE 90 oil ratio of 50:50 & lubricate by SAE 90 oil.(Customer to use OKS chain lub spray at every 500 kms)

PERIODIC MAINTENANCE & LUBRICATION CHART

Sr. No.	Activities / Check points	Recommended frequency - Service interval & Kms							
		Servicing	1st (Free)	2nd (Free)	3rd	4th	5th	6th	7th
		KMS	500 750	4500 5000	9500 10000	14500 15000	19500 20000	24500 25000	29500 30000
27.	Side stand pivot pin	C,L					C,L		
28.	Steering play	C,A	C,A	C,A	C,A	C,A	C,A	C,A	C,A
29.	Steering stem bearing & Cap steering bearing (Plastic)**	C,CL,L			C,CL,L		C,CL,L		C,CL,L
30.	Front fork oil & seal	C,R	C,R	C,R	C,R	C,R	C,R	C,R	R
31.	Step-pillion LH & RH (Ball & Plate)	CL,L		CL,L	CL,L	CL,L	CL,L	CL,L	CL,L
32.	Swing arm NRB for more play	L							
33.	Brake pads Front & Rear for wear limit.	C,R	C,R	C,R	C,R	R	C,R	C,R	R
34.	Check source of leakages if any in the brake system. Check Front & rear brake hose condition. Check Brake fluid level and top up, if needed.	C,A,R	C,A,R	C,A,R	C,A,R	C,A,R	C,A,R	C,A,R	R
35.	Rear sprocket fasteners for looseness.	C,T	C,T		C,T		C,T		C,T
36.	Rear wheel rubber shock dampers for excess play.	C,R			C,R		C,R		C,R
37.	Fairing & windshield well nuts for rubber cracks	C,R			C,R	C,R	C,R	C,R	C,R
38.	Clutch & Throttle cable free play	C,A	C,A	C,A	C,A	C,A	C,A	C,A	C,A
39.	Head light focus adjustment	C,A	C,A	C,A	C,A	C,A	C,A	C,A	C,A

PERIODIC MAINTENANCE & LUBRICATION CHART

Recommended frequency - Service interval & Kms									Remarks
8th	9th	10th	11th	12th	13th	14th	15th	16th	
34500 35000	39500 40000	44500 45000	49500 50000	54500 55000	59500 60000	64500 65000	69500 70000	74500 75000	
	C,L				C,L				Use recommended AP grease.
C,A	C,A	C,A	C,A	C,A	C,A	C,A	C,A	C,A	
	C,CL,L		C,CL,L		C,CL,L		C,CL,L		Replace if required. Use Limaplex grease for lubrication
C,R	C,R	C,R	C,R	C,R	R	C,R	C,R	C,R	Replace oil and oil seal and dust seal in pair at every 30000 Kms.
CL,L	CL,L	CL,L	CL,L	CL,L	CL,L	CL,L	CL,L	CL,L	Replace ball & plate, if required.
	L								Lubricate NRB at every 40,000 Kms. Use AP grease.
C,R	C,R	R	C,R	C,R	R	C,R	C,R	R	Replace at every 15000 Kms.
C,A,R	C,A,R	C,A,R	C,A,R	C,A,R	R	C,A,R	C,A,R	C,A,R	Check & Top up DOT 4 brake oil in every service. Replace DOT 4 brake oil & Master / Caliper seals at every 30000 Kms.
	C,T		C,T		C,T		C,T		Use model wise torque values.
	C,R		C,R		C,R		C,R		Replace rear wheel rubber shock damper if required
C,R	C,R	C,R	C,R	C,R	C,R	C,R	C,R	C,R	Replace if rubber found hard
C,A	C,A	C,A	C,A	C,A	C,A	C,A	C,A	C,A	Replace cables if operation found hard.
C,A	C,A	C,A	C,A	C,A	C,A	C,A	C,A	C,A	

PERIODIC MAINTENANCE & LUBRICATION CHART

Sr. No.	Activities / Check points	Recommended frequency - Service interval & Kms							
		Servicing	1st (Free)	2nd (Free)	3rd	4th	5th	6th	7th
		KMS	500 750	4500 5000	9500 10000	14500 15000	19500 20000	24500 25000	29500 30000
40.	Check & confirm all bulbs / switches working.	C,A	C,A	C,A	C,A	C,A	C,A	C,A	C,A
41.	General lubrication – Clutch lever	L	L	L	L	L	L	L	L
42.	Tyre air pressure.	C,A	C,A	C,A	C,A	C,A	C,A	C,A	C,A
43.	Mirror position & joint firmness.	C,A	C,A	C,A	C,A	C,A	C,A	C,A	C,A
44.	All fasteners tightness,	C,T	C,T	C,T	C,T	C,T	C,T	C,T	C,T
	1.Front & rear axle								
	2.Swing arm axle								
	3.Engine foundation								
	4.Rider foot rest								
5.Pillion stay									

*It is strongly recommended to use only Bajaj genuine oil.

C: Check, A: Adjust, CL: Clean, R: Replace, T: Tighten, L: Lubricate

FOLLOWING ITEMS ARE CHARGEABLE TO CUSTOMER.

Oil, Coolant, Filters, All types of greases, Cleaning agents, Cables, Wear & tear parts, Rubber O rings/oil seals/pipes, Gaskets etc.

PERIODIC MAINTENANCE & LUBRICATION CHART

Recommended frequency - Service interval & Kms									Remarks
8th	9th	10th	11th	12th	13th	14th	15th	16th	
34500 35000	39500 40000	44500 45000	49500 50000	54500 55000	59500 60000	64500 65000	69500 70000	74500 75000	
C,A	C,A	C,A	C,A	C,A	C,A	C,A	C,A	C,A	If found sticky then use recommended WD40 spray
L	L	L	L	L	L	L	L	L	Use recommended AP grease.
C,A	C,A	C,A	C,A	C,A	C,A	C,A	C,A	C,A	Ensure model wise tyre air pressure.
C,A	C,A	C,A	C,A	C,A	C,A	C,A	C,A	C,A	
C,T	C,T	C,T	C,T	C,T	C,T	C,T	C,T	C,T	Use model wise torque values.

NON-USE MAINTENANCE

Non-use maintenance is necessary if a vehicle remains off road for a longer duration (more than 15 days**). The correct and careful non-use maintenance carried out before storing the vehicle will prevent the vehicle from rusting and from such other non-operational damages like fire hazards.

- Clean the entire vehicle thoroughly.
- Empty the fuel from the fuel tank and (if fuel is left in for a longer time, the fuel will break and gummy substance could clog the Fuel pump & Throttle body.
- Remove spark plug & put several drops of Engine oil into the cylinder. Self start engine over slowly a few times to coat cylinder wall with oil & install back spark plug.
- Set the vehicle on a box or a stand so that both wheels are raised off the ground.
- Use antirust spray (Proto Quick LTP 902 - P. No. : 37254039) on all vehicle fasteners & plated parts to avoid rust formation.
- Cover entire vehicle neatly. Make sure that storage area is well ventilated & free from any

source of flames or spark.

- Fill 10% excess air pressure in both wheels.
- Do not apply oil on front / rear brake disc, to prevent rusting. If the brake disc rusts during storage, do not attempt to clean it with soap water. The rust will go off automatically during first few application of brake.

** FOR BATTERY

- a. Remove battery and keep it on wooden plank, in properly ventilated area.
 - b. Before taking the vehicle for use.
- Get the battery recharged from the Authorised Service Center / Battery Dealer.
 - Apply petroleum jelly on terminals. (applicable to certain models).

PREPARATION FOR REGULAR USE AFTER STORAGE

- Follow daily safety checks.

DELIVERY CERTIFICATE

FRAME NO.

ENGINE NO.

Sold on.: _____

Customer's Name Mr/Mrs/Miss: _____

Address: _____ Contact No.: _____

I have taken possession of motorcycle along with the following items.

- | | |
|-------------------|-------------------------------------|
| 1. Owner's Manual | 5. Standard Accessories |
| 2. 2 nos of key | 6. Battery Make _____ Sr. No. _____ |
| 3. Set of tools | 7. Tyre Fr Make _____ Sr. No. _____ |
| 4. First Aid Kit | Rr Make _____ Sr. No. _____ |

The Vehicle has been delivered to my satisfaction & I have understood all terms and conditions of warranty, service schedules & maintenance tips and shall abide by them.

Customer's Signature

(To be filled in by the dealer)

Dealer Code :
Dealer Name :
Address :
Contact No. :

Imp: "Do not detach this page from Owner's Manual"

WARRANTY: SCOPE & LIMIT

Bajaj Auto Limited provides the following warranty in respect of the “**Dominar 400 BS VI**” motorcycle manufactured by us.

Every possible care and precaution has been taken to ensure quality in respect of the material & workmanship in the vehicles manufactured by us. Bajaj Auto Limited will repair or replace at their Authorised Workshops, free of charge, part or parts there of as may be found, on examination, to have manufacturing defect within a period of 5 Years or 75,000 Kms., whichever is earlier from the date of sale subject to fulfillment of conditions stipulated in part A, B & C given here under

Note : Warranty is applicable for only first owner of vehicle.

Part A:

Warranty claims in respect of such items like shock absorbers, speedometers etc. though claimed through us, are subject to acceptance of the respective manufacturers. In all such cases the decision of the respective manufacturer will be final and binding.

Proprietary parts like tyres, tubes and battery are warranted by their respective manufacturers and should be claimed on them directly by the customer. Bajaj Auto Limited shall not be Liable to replace them though their dealer,

however Bajaj Dealers will provide full assistance in referring such claims with respective manufacturer.

Bajaj Auto Limited undertake no liability in the matter of consequential loss or damage caused due to the failure of the parts. Delay, if any, at the repairing workshop in carrying out repair to vehicle shall not be a ground for extending the warranty period, nor shall it give any right to the customer for claiming any compensation for damages.

Bajaj Auto Limited reserves the right either to repair or replace the defective parts.

Where a defective part can be replaced by part/s of alternative brand/s, which are normally used by Bajaj Auto Limited in the course of manufacture, Bajaj Auto Limited reserves the right to carry out the replacement by a part or parts of any such alternative brand/s.

This warranty and any claim arising there, is subject to Pune jurisdiction only.

Part B:

No claim for exchange or repair can be considered unless the customer :

- a. Ensures that immediately upon detection of the defect, he approaches any nearest Authorised Bajaj Vehicle Dealers & Recommended Authorised Service Dealers with the concerned vehicle and enables him



to remove and despatch the part / parts attributing to the manufacturing defect to the Company.

- b. Produces the Owner's Manual, in original, to enable that dealer to verify the details.

It must be expressly understood that claims forwarded directly to us by the owner / customer will not be entertained at all and such defective part/parts thus forwarded by them will lie at our factory at their own risk, and this warranty shall not be enforceable.

To avail benefits of warranty, following are mandatory

1. Availing of Initial 3 Free Services without lapse.
2. Availing paid services at subsequent 5000 kms. or 120 days from last service whichever is earlier without any lapse.
3. Availing of all services at the Authorised Vehicle Dealers & Recommended Authorised Service Dealers.
4. Usage of only recommended engine oil **"Bajaj DTS-I 10000 10W50"** at specified frequency for drain interval of 10,000 kms. & engine oil level top-up at 5000 kms.
5. Replacing mandatory periodic parts such as air filter, oil filter etc. as per periodic maintenance schedule.

Part C :

Further this warranty is NOT applicable to :

1. Normal maintenance operations like brake & clutch adjustments, cleaning of fuel system, engine tune-up or such other adjustments.
2. Parts subjected to normal wear & tear like Clutch Plates, Brake Shoes, Chain, Sprockets, Fork Oil Seal, Spark Plug, Control Cables, Brake Pads.
3. Replacement of bulbs & rubber components like grommets, 'O' rings, bellows as well as filters, packings, gaskets, fasteners etc.
4. Painted parts. Only blistering or peeling off of paint film are covered under warranty. Any defect arising out due to external damages or due to usage of protective covers /additional protective coatings adverse atmospheric conditions etc. are not allowed like under warranty.
5. All consumables like Engine oil, Fork oil, Brake Oil, Grease etc. are chargeable to customer.
6. Any defect arising due to above consumables not changed as per scheduled or if used other than the recommended one.
7. Never drive your bike through flooded roads or a flooded patch, as damages to the engine parts due to water entry is not covered under warranty.

8. All chrome plated parts are prone to rust or corrosion in coastal area or in acidic environment or due to neglected cleaning etc. However chrome film peeling is covered under warranty in general atmospheric conditions. Blue/ Yellow colouration of silencer near exhaust port is permissible and hence not covered under warranty.
 9. Oxidation of unpainted/painted crankcase, cylinder block, cylinder head etc. in acidic environment or in a coastal area.
 10. Parts of the vehicle that have been subjected to misuse, accident, negligent treatment OR which have been used in conjunction with parts & an equipment not manufactured or recommended for use by Bajaj Auto Limited, if found is the sole judgement of Bajaj Auto Limited, such use prematurely affects the performance and reliability of the vehicle.
 11. Parts of the vehicle that have been altered and modified or replaced in unauthorized manner like use of wider tyres, loud silencers etc and which in the sole judgement of the Bajaj Auto Limited affects its performance and reliability.
 12. **Vehicles which are not being serviced at recommended dealers as per the service schedule described or which have not been operated or maintained in accordance with the instructions maintained in the Owner's Manual.**
 13. Vehicles used for any competition or race and/or for attempting to set up any kind of record.
 14. Any failure arising due to use of adulterated or bad quality fuel.
Parts affected due to bad fuel quality are not covered Under warranty.
 15. If additional electrical accessories such as - Remote, Bigger horn, Musical brake light etc. fitted on vehicle.
 16. If the vehicle has been used for commercial purpose like Taxi or any other means of commercial transportation.
- Bajaj Auto Limited reserves the right to make any changes in design or to add any improvements on the vehicle at any time without incurring any obligation to install the same on a vehicle previously supplied and sold. Also, the conditions of this warranty are subject to alteration without any notice.
- This warranty is the entire written warranty given by Bajaj Auto Limited for “**Dominar 400 BS VI**” motorcycle’ and no other dealer or its or his agent or employee is authorised to extend or enlarge this warranty.

BATTERY WARRANTY CARD

MAKE OF BATTERY : _____ MFG. CODE OF BATTERY: _____
 BATTERY SR. NO.: BATTERY CHARGING DATE:
 TYPE OF BATTERY: _____ VEHICLE SALE DATE: _____
 NAME OF OWNER AND ADDRESS: _____

TYPE OF VEHICLE: _____ REG. NO.: _____
 FRAME NO.: _____ ENGINE NO.: _____

SERVICE RECORD

Sr. No.	Date	Age Mths.	Specific Gravity	Voltage	Remarks	Dealer's Stamp & Signature	* Code
1.							
2.							
3.							
4.							
5.							
6.							

*CODE FOR REMARKS:

LL : Low electrolyte level.
 AE : Electrical system needs attention.
 IR : Insufficient running of vehicle.
 CB : Cover broken.
 BC : Broken Container.
 PM : Poor maintenance.
 BA : Battery abused.

NOTE

Customer should insist that "Service Record" must be filled by respective authorised battery dealer as proof of specified maintenance for easy settlement of claim, if any.

TO BE FILLED IN BY BATTERY DEALERS / DISTRIBUTORS IN CASE OF CLAIM

Name of Dealer & Code: _____

Date of claim: _____ Battery Type : _____

Serial No.: _____ Date of Fitment: _____

FAILURE MODE (PLEASE TICK AS APPLICABLE)

- Loose connection
- Internal Short
- Plate Shedding
- Intercell Connection
- Does not Hold Charge
- Wrong Assembly
- Wrong Application
- Terminal Corroded
- Overcharge / Undercharge
- Reverse Charge
- High Specific Gravity Electrolyte
- Electrolyte Contamination
- Electrolyte Level not Maintained
- Left Lying Idle

Claim Accepted

Claim Rejected

Details of Repair, if any _____

NOTE

Please contact nearest respective authorised battery dealer for details immediately after purchase of vehicle.



4T
Premium
Engine Oil

LONGEST ENGINE OIL CHANGE INTERVAL OF 10,000* KM

Synthetic Engine Oil Ultimate Performance



Reduced
Friction



Clean Engine
Parts



Smooth
Clutch Control



THE WORLD'S
FAVOURITE
INDIAN



TOP UP
BOTTLE
150 ml.



ALWAYS USE
BAJAJ GENUINE PARTS
& HIGH PERFORMANCE
ENGINE OILS



*Top up recommended at 5000 km.



We are committed to provide the best of sales & service experience, however should you require any additional assistance, please call our Call centre on the number given below,

 : 7219821111

Call charges are as applicable

**Call centre timings :- Monday to Sunday
(09 : 00 am - 08 : 00 pm)**

 Please download customer care app from '**Google play store**' and '**Apple store**' and book the vehicles for servicing and more on your phone.

E-mail : customerservice@bajajauto.co.in

Web Site : www.bajajauto.com

CIN : L65993PN2007PLC130076