

16 inch lid

2 inch threaded fitting

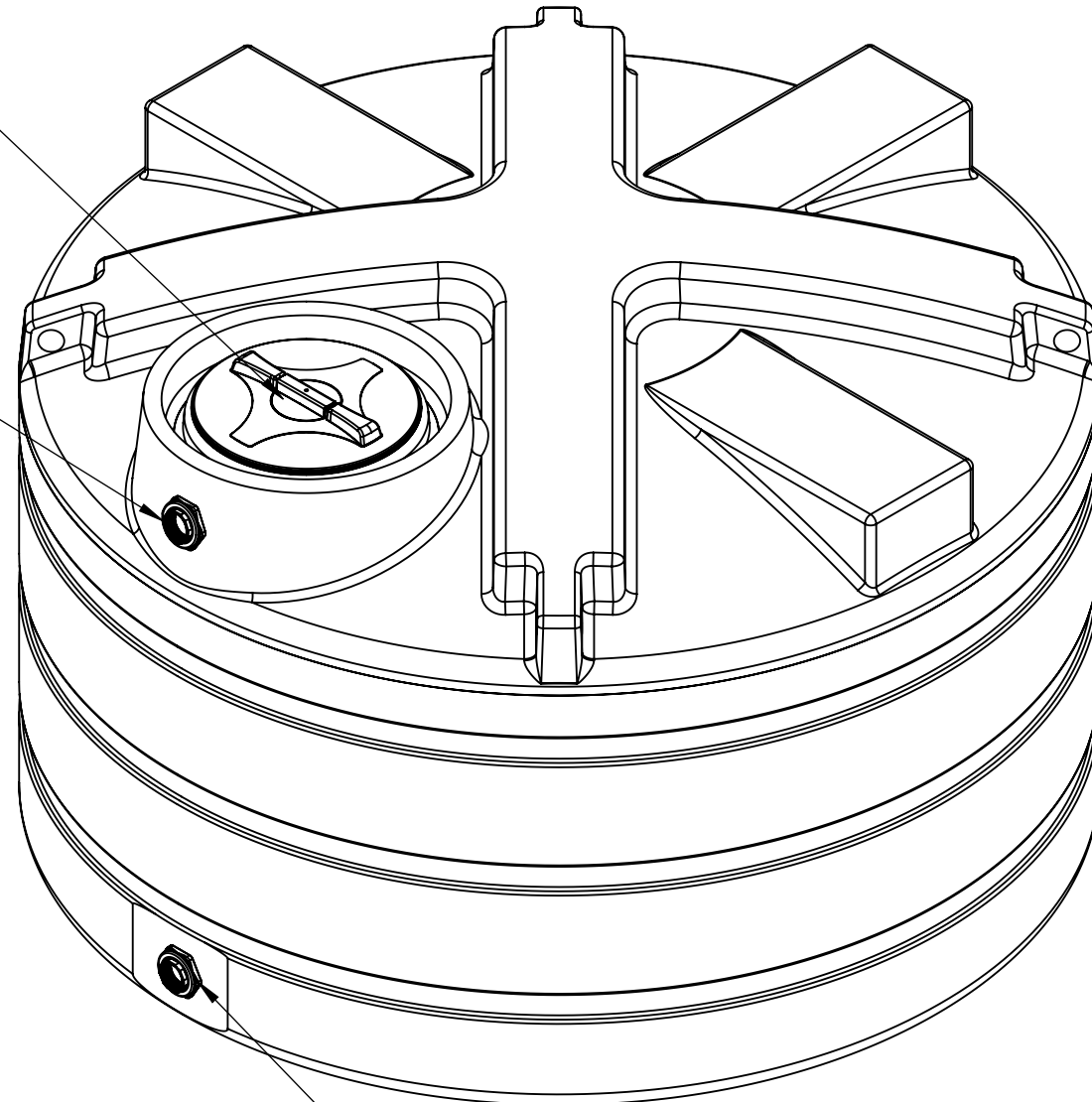

2 inch threaded fitting

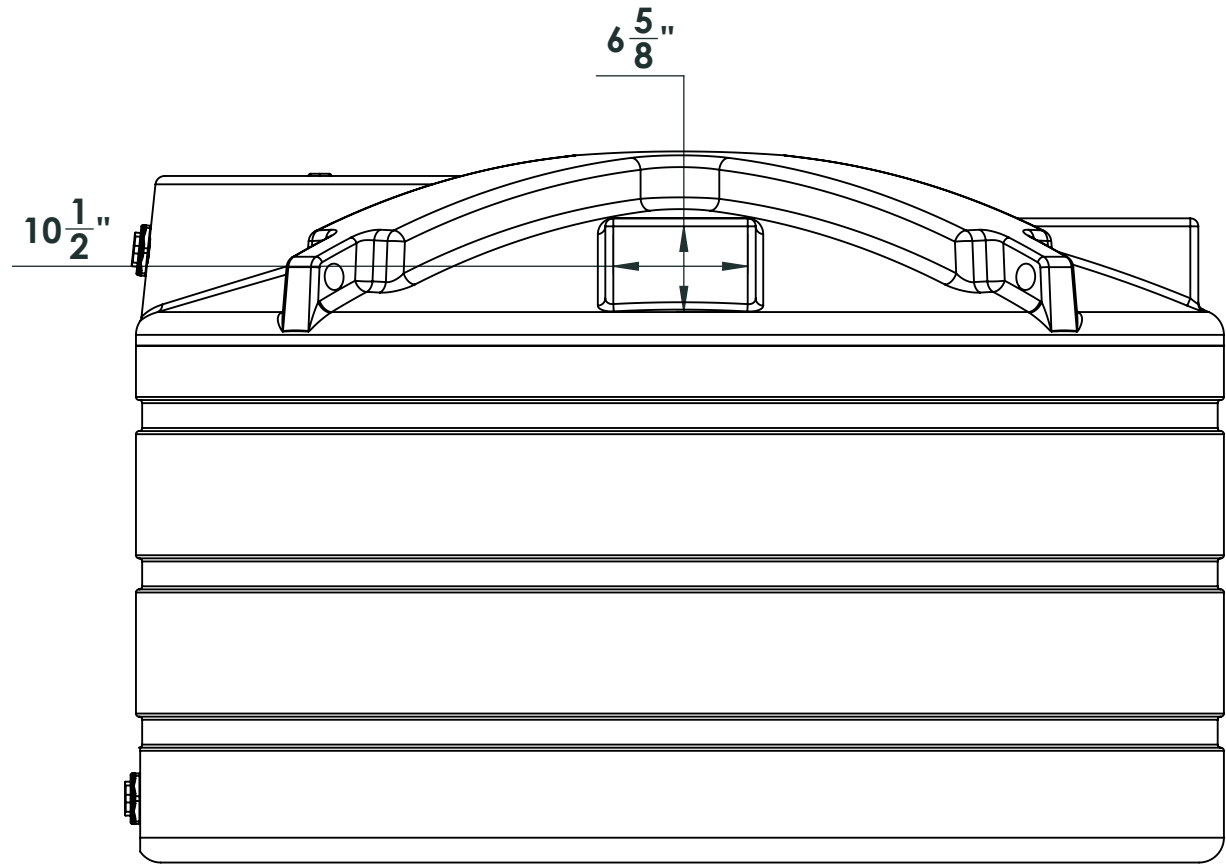
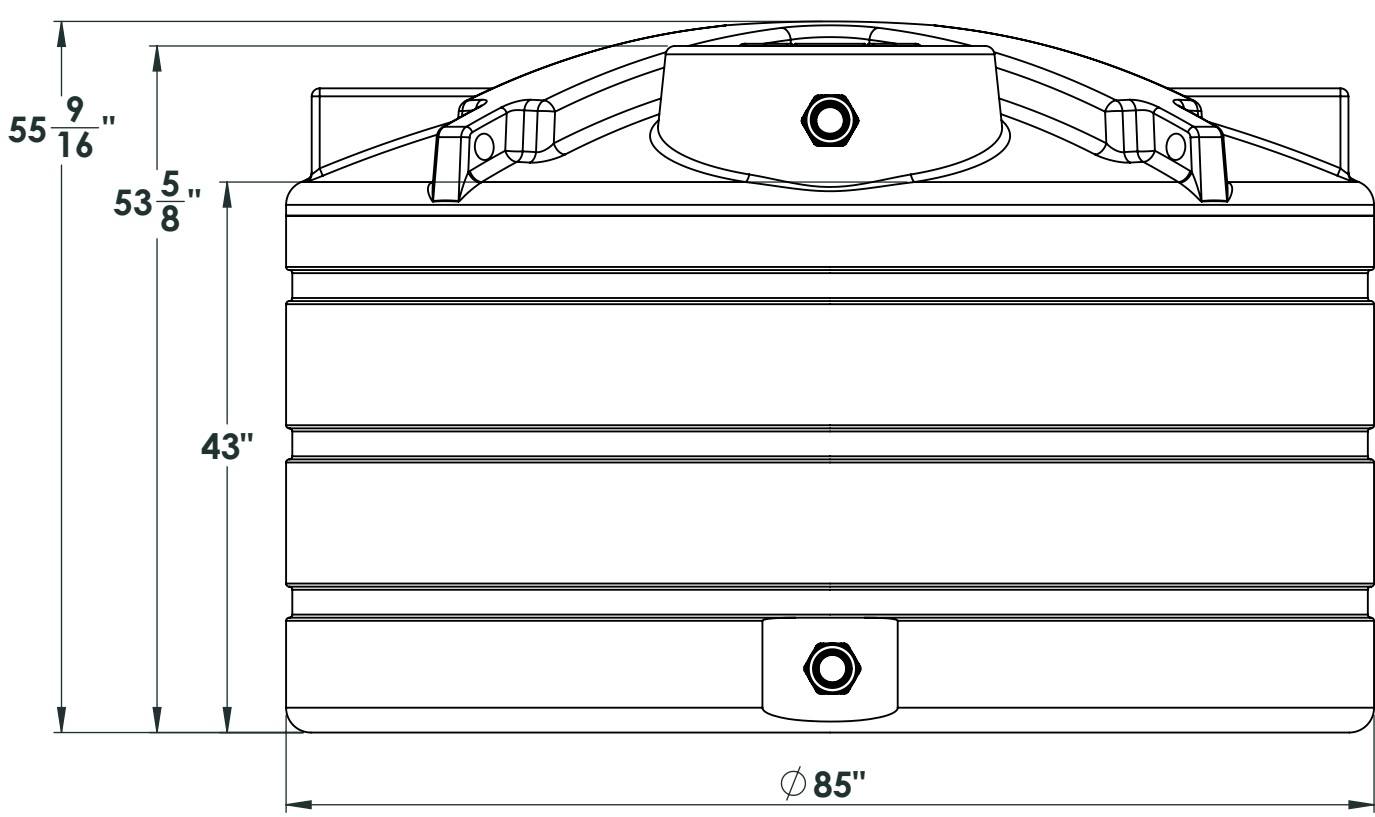

**NOTE: Allow +/- 1.5% Shrinkage**

**PROPRIETARY AND CONFIDENTIAL**  
 THE INFORMATION CONTAINED IN THIS DRAWING IS THE SOLE PROPERTY OF **ENDURAPLAS LLC**. ANY REPRODUCTION IN PART OR AS A WHOLE WITHOUT THE WRITTEN PERMISSION OF **ENDURAPLAS LLC** IS PROHIBITED.

UNLESS OTHERWISE SPECIFIED:		NAME	DATE	<b>ENDURAPLAS LLC</b> TITLE: <b>TLV01125</b> SIZE DWG. NO. REV <b>C</b> <b>1</b> SCALE: 1:50 WEIGHT: SHEET 1 OF 1	
DIMENSIONS ARE IN INCHES		DRAWN	DNS		10/31/16
TOLERANCES:		CHECKED			
FRACTIONAL ±		ENG APPR.			
ANGULAR: MATCH ±		MFG APPR.			
TWO PLACE DECIMAL ±		Q.A.			
THREE PLACE DECIMAL ±		COMMENTS:			
INTERPRET GEOMETRIC TOLERANCING PER:					
MATERIAL					
FINISH					
NEXT ASSY	USED ON				
APPLICATION	DO NOT SCALE DRAWING				