



DR SERIES UP TO 8 ACRES

The Keeton Industries DR series of lake bed aeration systems are the ideal choice for ponds and lakes up to 10 surface acres in size. The DR series superior design is unmatched in energy efficiency, effectiveness and sound reduction. These systems feature 1/2HP Gast Rocking Piston compressors, high volume cooling blowers, programmable digital timers and fully adjustable aluminum manifolds housed in attractive, 100% recycled plastic cabinets. The DR series can operate up to 8 self-cleaning, non-clogging Duraplate™ membrane diffusers. Duraplate diffusers emit millions of tiny bubbles that increase dissolved oxygen levels while eliminating stratification, improving water quality and clarity. Like all of our aeration systems, the DR series are backed by a full 2 year warranty.



Model	Features	Acres
DR-4DP	4 Diffuser and 2 Compressors	Up to 4 Acres
DR-6DP	6 Diffusers and 2 Compressors	Up to 6 Acres
DR-8DP	8 Diffusers and 2 Compressors	Up to 8 Acres



Shown with Level-aer Equipment Pad
– additional upgrade.



- The Compressors**
- 1/2 HP Rocking Piston
 - 10.6 cfm air flow
 - 40psi max pressure
 - 115V – 10.6A max, 5.2A average
 - Thermal overload protection
 - Pressure relief valve
 - Intake filter
 - Pressure Gauge



- The Tubing**
- Self-weighted
 - 1/2" I.D. with 1/4" sidewalls
 - Fishhook resistant
 - Will not kink or break
 - Available in 100' and 500' lengths
 - 15 year warranty



- The Diffuser**
- Self-cleaning
 - Non-clogging
 - Self-weighted
 - Fishhook resistant
 - High Oxygen transfer
 - Lifetime warranty

- The Cabinet**
- 100% recycled plastic cabinet
 - 20"W x 24"L x 27" T
 - 135cfm cooling blower
 - Sound reduction package
 - 1" ASTM certified Acoustical Foam
 - Programmable digital timer
 - (2) 4-valve adjustable aluminum manifold
 - 8' grounded plug



OTHER PONDS AND LAKES ARE GREEN WITH ENVY®

keetonaquatics.com | 800.493.4831 | 970.568.7754



DR SERIES
UP TO 8 ACRES

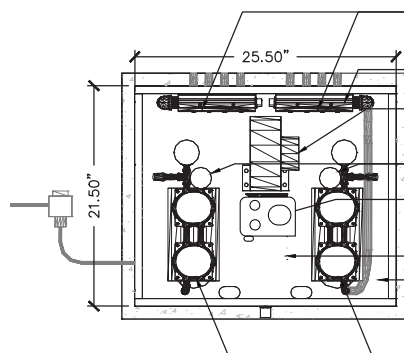
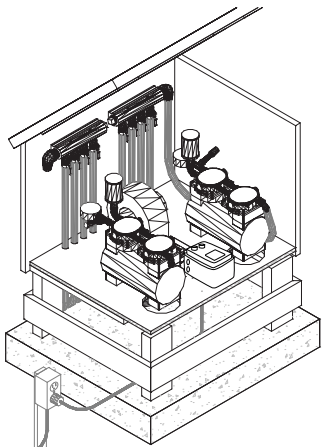

TOP VIEW (SEE SHEET #2)
NOT TO SCALE

- MODEL FFP-546-4 ALL ALUMINUM MANIFOLD WITH PRESSURE RELIEF VALVE, LIQUID-FILLED STAINLESS STEEL PRESSURE GAUGE (0-30 PSI RATED) AND 4-VALVE MANIFOLD WITH BRASS BARB OUTLETS.
- DR QUIET LINE AERATION SYSTEM CABINET MADE OF 100% RECYCLED PLASTIC WITH THE DIMENSIONS F 25.50" (L) X 21.50" (W) X 18.50" (H).
- HIGH-FLOW SQUIRREL CAGE BLOWER, RATED AT 135 CFM FOR CABINET COOLING. FAN COMES WITH OILABLE BEARINGS AND SCREENED INLET AND OUTLET OPENING(S).
- AIR FILTER ASSEMBLY (AC432) AND FILTER ELEMENT (AC393)
- CONTROLS 24 HOUR/ 7 DAY DIGITAL TIMESWITCH, 120V, SPST AND SPDT SWITCHING, 1 CHANNEL, 6.3MM X 0.8MM TAB TERMINAL(S) CONNECTION(S) (COMPLIES WITH DIN 46244).
- 120V OUTLET
- INTERIOR OF CABINET, FITTED AND GLUED WITH ACOUSTICAL CONVOLUTED FOAM INSULATION. 1" ASTM RATED C 423-90A, TO THE NEAREST 0.05 SABS/FT² WITH A NOISE REDUCTION COEFFICIENT OF 0.40. OSHA APPROVED SOUNDPROOFING AND UL-94 RATING.
- 1/2 HP GAST (MODEL 75R640) ROCKING PISTON COMPRESSOR WITH AIR OUTPUT OF 4.45 CFM AT 0 PSI, 40 PSI MAXIMUM CONTINUOUS DUTY OPERATION. COMPRESSOR DRAWS A MAXIMUM OF 5.3 AMPS @ 115V. COMPRESSOR IS WIRED FOR 115V AND IS FITTED WITH A DUPLEX WIRING BOX/ PLUG, SERVICING THE COMPRESSOR AND COOLING FAN.

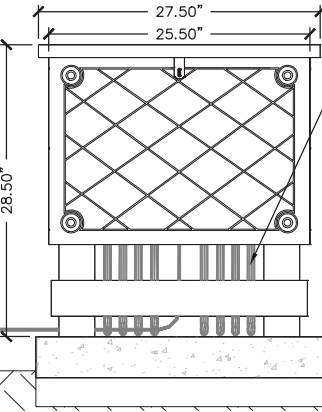

FRONT VIEW
NOT TO SCALE

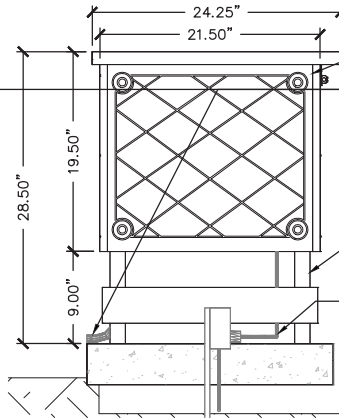

SIDE VIEW
NOT TO SCALE

- DR QUIET LINE AERATION SYSTEM CABINET MADE OF 100% RECYCLED PLASTIC WITH THE DIMENSIONS F 25.50" (L) X 21.50" (W) X 18.50" (H). CABINET LID COVER SECURED WITH PIANO HINGE (BACK) AND LOCKABLE HASP (FRONT).
- (4-8) AIR OUTLET LINES FROM COMPRESSOR THROUGH CABINET WITH 1/2" 220 PSI RATED FLEXIBLE BRAIDED VINYL TUBING. EACH FLEXIBLE TUBING OUTLET SHALL BE 4'-0" LONG AND FITTED WITH 1/2" ID BARB CONNECTS. ALL AERATION SYSTEMS SHALL BE FURNISHED WITH STAINLESS STEEL 1/2" WORMDRIVE CLAMPS TO FIT 3/8" - 1/2" HOSE, MODEL 67-06-1 TO CONNECT ON SHORE AND TO DURAPLATE(S) (DDP-9) IN LAKE.
- CABINET IS CONSTRUCTED WITH (4) LEGS THAT CAN BE BOLTED TO A CONCRETE SLAB (30" (L) X 30" (W) X 4" (H)).
- SYSTEM COMES WITH 8' 120V (14-3) HEAVY DUTY WIRING CORD WITH PLUG END.

1520 Aquatic Drive
Wellington, Colorado 80549
O: (970) 568-7754
TF: (800) 493-4831
www.keetonaquatics.com

TITLE: QUIET LINE AERATION SYSTEM DR 4-8 SERIES - MULTI VIEW	
DATE: 1/17/2012	SHEET: 1



OTHER PONDS AND LAKES ARE GREEN WITH ENVY®

keetonaquatics.com | 800.493.4831 | 970.568.7754