

Weather Proofing Enclosure

1/2" Jumper to Antenna

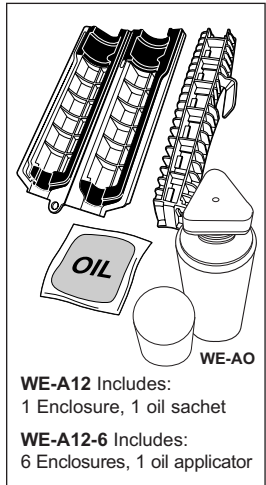

Body shell
Part description Body Shell
Part number WE-A12

Dimensions (in mm)

Product size	Length L	Height H	Width W	Internal diameter Di	Internal length Li
WE-A12	152,3 (+/-1)	46,9 (+/-0.5)	41,7 (+/-0.5)	26,0 (+/-0.5)	91,5 (+/-0.5)

Closing channel
Part description Closing Channel
Part number WE-A12

Dimensions (in mm)

Product size	Length L
WE-A12	146,0 (+/-1)

Cable Diameter:
1/2" JUMPER CABLE
ømin. 13
ømax. 17

1 The Andrew Weather Proofing Enclosure is a hermetically sealed device. Any moisture sealed into the kit will stay inside the enclosure. To ensure that the enclosure stays moisture free, make sure all connections are dry before applying the unit.

2

Seals must be lubricated for rotating purposes.

Be Safe:
Apply oil while on the ground only.

3

Important:
To ensure seal is not compromised, **KEEP STRAIGHT.**

±100mm

4

5

6

±100mm

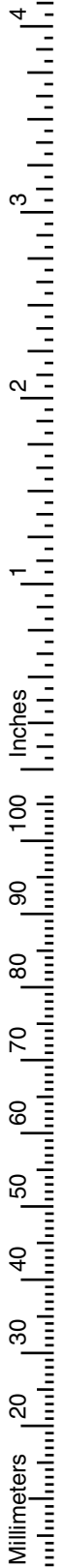

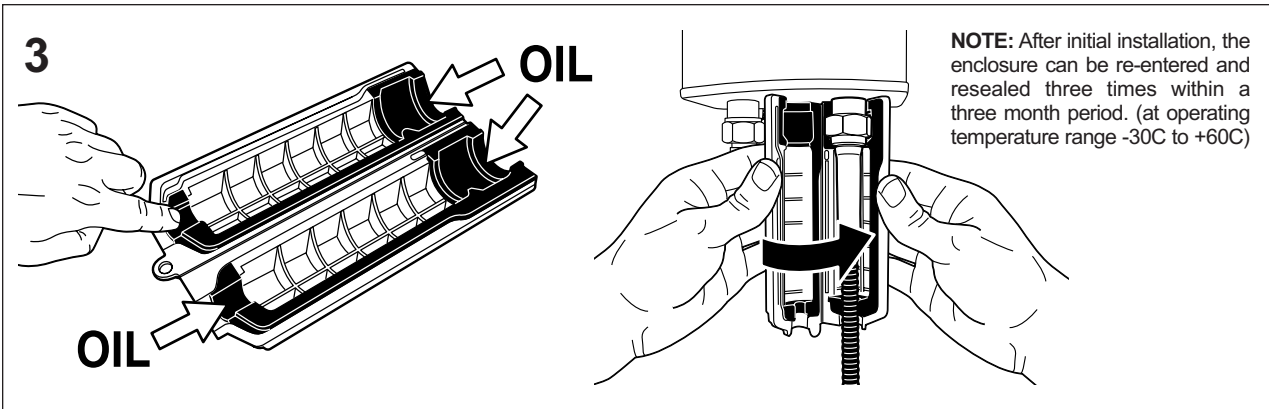
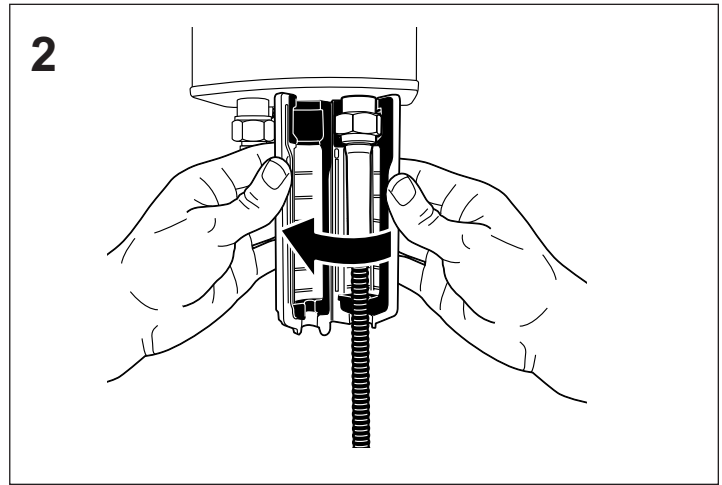
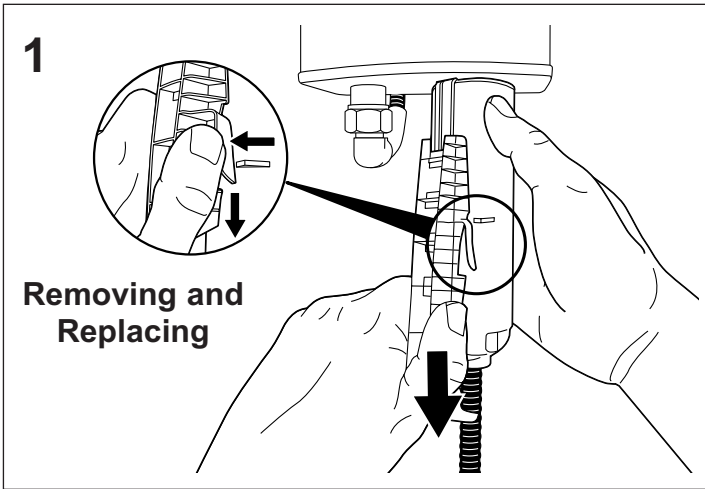

Notice: Andrew disclaims any liability or responsibility for the results of improper or unsafe installation, inspection, maintenance, or removal practices.

Aviso: Andrews no acepta ninguna obligación ni responsabilidad como resultado de prácticas incorrectas o peligrosas de instalación, inspección, mantenimiento o retiro.

Avis : Andrew décline toute responsabilité pour les conséquences de procédures d'installation, d'inspection, d'entretien ou de retrait incorrectes ou dangereuses.

Hinweis: Andrew lehnt jede Haftung oder Verantwortung für Schäden ab, die aufgrund unsachgemäßer Installation, Überprüfung, Wartung oder Demontage auftreten.

Atenção: A Andrew abdica do direito de toda responsabilidade pelos resultados de práticas inadequadas e sem segurança de instalação, inspeção, manutenção ou remoção.

Avvertenza: Andrew declina eventuali responsabilità derivanti dall'esecuzione di procedure di installazione, ispezione, manutenzione e smontaggio improprie o poco sicure.

注意 Andrew 公司申明對於不恰當或不安全的安裝、檢驗、維修或拆卸操作所導致的後果不負責任 何義務和責任



Andrew Corporation

10500 West 153rd Street
Orland Park, IL U.S.A. 60462

Telephone: 708/349-3300

FAX (U.S.A.): 1-800/349-5444

Internet: <http://www.andrew.com>

Customer Service, 24 hours: U.S.A. • Canada • Mexico: 1-800/255-1479

U.K.: 0800 250055

Other Europe: +44 592 782 612

Printed in U.S.A. 10/04

Copyright © 2004 by Andrew Corporation