



**XBC-EX-6820/15**  
**XBC-EX-7820/15**



**OWNER'S MANUAL**

**MADE IN THE U.S.A.**

Rev. 11-9-2022





# TABLE OF CONTENTS

Introduction.....	5
Safety .....	7
Decals.....	12
Pre-Operation.....	14
Installation Instructions.....	15
Operating Instructions.....	16
Troubleshooting .....	18
Lubrication.....	21
Maintenance.....	22
Bolt Torque Specifications.....	29
Specifications.....	30
Parts Section.....	31
Limited Warranty .....	35

**READ ENTIRE MANUAL BEFORE  
OPERATING EQUIPMENT!**

**If you do not understand any section of this manual and/or function of this product please contact your local authorized dealer immediately.**



This is the "Safety Alert Symbol" used by this industry. This Symbol is used to warn of possible injury. Be sure to read all warnings carefully. They are included for your safety and for the safety of others working with you.

THIS SYMBOL BY ITSELF OR WITH A WARNING WORD IS USED THROUGHOUT THIS MANUAL TO CALL YOUR ATTENTION TO INSTRUCTIONS INVOLVING YOUR PERSONAL SAFETY OR THE SAFETY OF OTHERS.

***FAILURE TO FOLLOW THESE INSTRUCTIONS CAN RESULT IN INJURY OR DEATH.***

## Introduction to Vail Products®

Thank you for purchasing Vail Products®. Our products have been specifically designed to meet and exceed the standards and requirements our customers demand. They have been field tested under the most severe conditions to provide consistent and reliable service with minimum downtime.

### GENERAL INFO

Only minor maintenance (such as cleaning and lubricating) is required to keep your Vail Products® unit in top operating condition. Be sure to observe all maintenance procedures and safety precautions in this manual and on any safety decals located on the product and

### BEFORE OPERATION

The primary responsibility for safety with the equipment falls to the operator. Make sure the equipment is operated only by trained individuals that have read and understand this manual. If there is any portion of this manual for function you do not understand, contact your local authorized dealer or the manufacturer to obtain further assistance. Keep this manual available for reference. Provide the manual to any new owners and/or operators.

### SERVICE INFO

Use only Vail Products® replacement parts. Substitute parts may not meet the required specifications. Record the model & serial numbers of your unit in this manual. The parts department needs this information to ensure that you receive the correct parts.



***Never let anyone operate a Vail Products® unit without reading the "Safety Precautions" and "Operating Instructions" sections of this manual. Always choose hard, level ground to park the vehicle on and set the brake so the unit cannot move.***



## SAFETY PRECAUTIONS

### READ MANUAL PRIOR TO INSTALLATION



Improper installation, operation, or maintenance of this equipment could result in serious injury or death. Operator and maintenance personnel should read this manual, as well as all manuals related to this equipment and the prime mover thoroughly before beginning installation, operation, or maintenance. Always wear proper safety glasses, goggles or a face shield when driving pins in or out, or when any operation causes dust, flying debris or any other hazardous material.

**NOTE! FOLLOW ALL SAFETY INSTRUCTIONS IN THIS MANUAL AND THE PRIME MOVER'S MANUAL(S).**



### READ AND UNDERSTAND ALL SAFETY STATEMENTS

Read all safety decals and safety statements in all manuals prior to operating or working on this equipment. Know and obey all OSHA regulations, local laws, and other professional guidelines for your operation. Know and follow good work practices when assembling, maintaining, repairing, mounting, removing, or operating this equipment.



### KNOW YOUR EQUIPMENT

Know your equipment's capabilities, dimensions and operations before operating. Visually inspect your equipment before you start, and never operate equipment that is not in proper working order with all safety devices intact. Check all hardware to ensure it is tight. Make certain that all locking pins, latches and connection devices are properly installed and secured. Remove and replace any damaged, fatigued or excessively worn parts. Make certain all safety decals are in place and are legible. Keep decals clean and replace them if they become worn or illegible.

## SAFETY PRECAUTIONS

**LOWER OR SUPPORT RAISED EQUIPMENT**

Do not work under raised booms without supporting them. Do not use support material made of concrete blocks, logs, buckets, barrels or any other material that could suddenly collapse or shift positions. Make sure support material is solid, not decayed, warped, twisted or tapered. Lower booms to ground level or on blocks. Lower booms and attachments to the ground before leaving the cab or operator's station.

**USE CARE WITH HYDRAULIC FLUID PRESSURE**

Hydraulic fluid under pressure can penetrate the skin and cause serious injury or death. Hydraulic leaks under pressure may not be visible. Before connecting or disconnecting hydraulic hoses, read your prime mover's operator's manual for detailed instructions on connecting and disconnecting hydraulic hoses or fittings.

- Keep unprotected body parts, such as face, eyes and arms as far away as possible from a suspected leak.
- *If injured by Hydraulic Fluid, seek Medical Attention at once.*
- Wear safety glasses, protective clothing and use a piece of cardboard or wood when searching for hydraulic leaks.

**NOTE! DO NOT USE YOUR HANDS! SEE ILLUSTRATION BELOW**

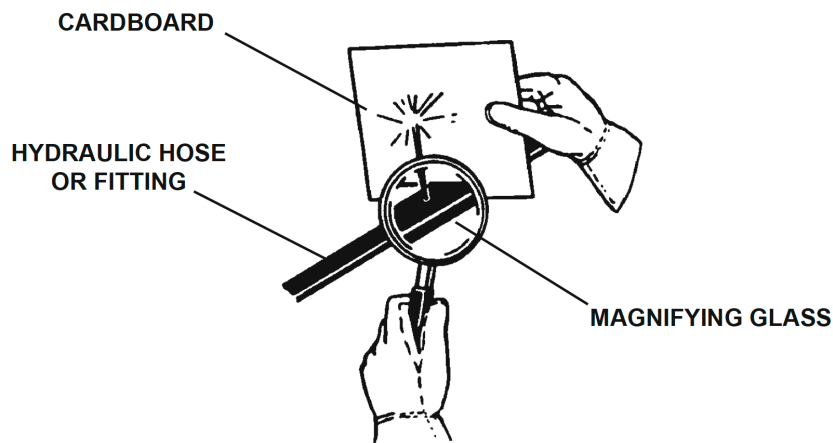



## SAFETY PRECAUTIONS



### DO NOT MODIFY MACHINE OR ATTACHMENTS

Modifications may weaken the integrity of the attachment and may impair the function, safety, life and performance of the attachment. When making repairs, use only the manufacturer's genuine parts, following authorized instructions. Other parts may be substandard in fit and quality. Never modify any ROPS (Roll Over Protection Structure) or FOPS (Falling Object Protective Structure) equipment or device.

**NOTE! ANY MODIFICATIONS MUST BE AUTHORIZED IN WRITING BY THE MANUFACTURER.**



### SAFELY MAINTAIN AND REPAIR EQUIPMENT

- Do not wear loose clothing or any accessories that can catch in moving parts. If you have long hair, cover or secure it so that it does not become entangled in the equipment.
- Work on a level surface in a well lit area.
- Use properly grounded electrical outlets and tools.
- Use the correct tools for the job at hand. Make sure they are in good condition for the task required.
- Wear the protective equipment specified by the tool manufacturer.



### SAFELY OPERATE EQUIPMENT

Do not operate equipment until you are completely trained by a qualified operator in how to use the controls, know its capabilities, dimensions and all safety requirements. See your machine's manual for instructions.

- Keep all step plates, grab bars, pedals and controls free of dirt, grease, debris and oil.
- Never allow anyone to be around the equipment when it is operating.
- Do not allow riders on the attachment or the prime mover.
- Do not operate the equipment from anywhere other than the correct operator's position.
- Never leave equipment unattended with the engine running, or with this attachment in a raised position.
- Do not alter or remove any safety feature from the prime mover or this attachment.
- Know your work site safety rules as well as traffic rules and flow. When in doubt on any safety issue, contact your supervisor or safety coordinator for an explanation.

## EQUIPMENT SAFETY PRECAUTIONS



### KNOW WHERE UTILITIES ARE

Observe overhead electrical and other utility lines. Be sure equipment will clear them. When digging, call your local utilities for location of buried utility lines, gas, water and sewer, as well as any other hazard you may encounter.



### EXPOSURE TO RESPIRABLE CRYSTALLINE SILICA DUST ALONG WITH OTHER HAZARDOUS DUSTS MAY CAUSE SERIOUS OR FATAL RESPIRATOR DISEASE.

It is recommended to use dust suppression, dust collection and if necessary personal protective equipment during the operation of any attachment that may cause high levels of dust.



### REMOVE PAINT BEFORE WELDING OR HEATING

Hazardous fumes/dust can be generated when paint is heated by welding, soldering or using a torch. Do all work outside or in a well ventilated area and dispose of paint and solvent properly. Remove paint before welding or heating. When sanding or grinding paint, avoid breathing the dust. Wear an approved respirator. Allow fumes to disperse thoroughly before welding or heating.



### END OF LIFE DISPOSAL

At the completion of the useful life of the unit, drain all fluids and dismantle by separating the different materials (rubber, steel, plastic, etc.). Follow all federal, state and local regulations for recycling and disposal of the fluid and components.



### OPERATING THE ATTACHMENT

- Block off work area from bystanders, livestock, etc. Falling trees or branches can cause severe injury or death.
- Let others know when and where you will be working. Make sure no one is behind the equipment or for several hundred feet in any direction around the equipment when in operation. Never allow anyone to approach the rotary cutter when in operation.
- Due to the potential danger of flying debris, it is the owner's responsibility and is "ABSOLUTELY MANDATORY that an IMPACT-RESISTANT, SHATTERPROOF 1/2" THICK POLYCARBONATE FRONT CAB DOOR" be installed on the machine to protect the operator.
- Operate only from the operator's station.
- Do not exceed rated operating capacity of the prime mover.
- Be sure all covers are properly installed before operating unit.
- Do not lift loads in excess of the capacity of the prime mover. Lifting capacity decreases as the load is moved further away from the unit.
- Never try to board or exit equipment while it is running.
- Test all controls before you begin operation.

## EQUIPMENT SAFETY PRECAUTIONS



### OPERATING THE ATTACHMENT

- When operating on slopes, drive up and down, not across. Avoid steep hillside operation, which could cause the prime mover to overturn.
- Reduce speed when driving over rough terrain, on a slope, or turning to avoid overturning the vehicle.
- An operator must not use drugs or alcohol, which can change his or her alertness or coordination. An operator taking prescription or over-the-counter drugs should seek medical advice on whether or not he or she can safely operate equipment.
- Never leave the attachment unattended when in the raised position. Always make sure the attachment is on the ground, parking brake is engaged, engine is turned off and the keys are removed before exiting the prime mover.



### TRANSPORTING THE ATTACHMENT

- Travel only with the attachment in a safe transport position to prevent uncontrolled movement. Drive slowly over rough ground and on slopes.
- When transporting on a trailer: Secure attachment using tie down accessories that are capable of maintaining attachment stability.
- Use extra care when loading or unloading the attachment onto a truck or trailer. Disconnect hydraulic couplers during transporting when installed on prime mover.
- When driving on public roads use safety lights, reflectors, Slow Moving Vehicle signs etc., to prevent accidents. Check local government regulations that may affect you.
- Do not drive close to ditches, excavations, etc., a cave-in could result.
- Do not smoke when refueling the prime mover. Allow room in the fuel tank for expansion. Wipe up any spilled fuel. Secure cap tightly when done.



### MAINTAINING THE ATTACHMENT

- Before performing maintenance, disengage auxiliary hydraulics, lower the attachment to the ground, turn off the engine, remove the key and apply the brakes. Be sure all rotation has stopped before making any adjustments or repairs.
- Never perform any work on the attachment unless you are authorized and qualified to do so. Always read the operator manual's before any repair is made. After completing maintenance or repair, check for correct functioning of the attachment. If not functioning properly, always tag **"DO NOT OPERATE"** until all problems are corrected.
- If attachment must be left raised for maintenance or any other reason, block the unit securely to prevent accidental release of the lifting mechanism. Serious damage or personal injury could result.
- Worn, damaged, or illegible safety decals must be replaced. New safety decals can be ordered from Vail Products®.
- Never make hydraulic repairs while the system is under pressure. Serious personal injury or death could result.
- Never work under raised attachment.



DANGER! 1/2" THICK SHATTERPROOF DOOR



WARNING! HIGH PRESSURE FLUID

DANGER! THROWN OBJECTS

DANGER! PINCH POINT



DANGER! ROTATING BLADES



DANGER! DO NOT OPERATE



DANGER! STAY CLEAR 300 FEET



DANGER! DO NOT EXIT



SERIAL PLATE



NO STEP



VAIL "V" LOGO



VAIL PRODUCTS® LOGO

## DECAL PLACEMENT

### GENERAL INFORMATION

The diagram on this page shows the location of all the decals used on your attachment. Reductions of the actual decals located on the previous page. Use this information to order replacements for lost or damaged decals. Be sure to read all decals before operating the attachment. They contain information you need to know for both safety and unit longevity.

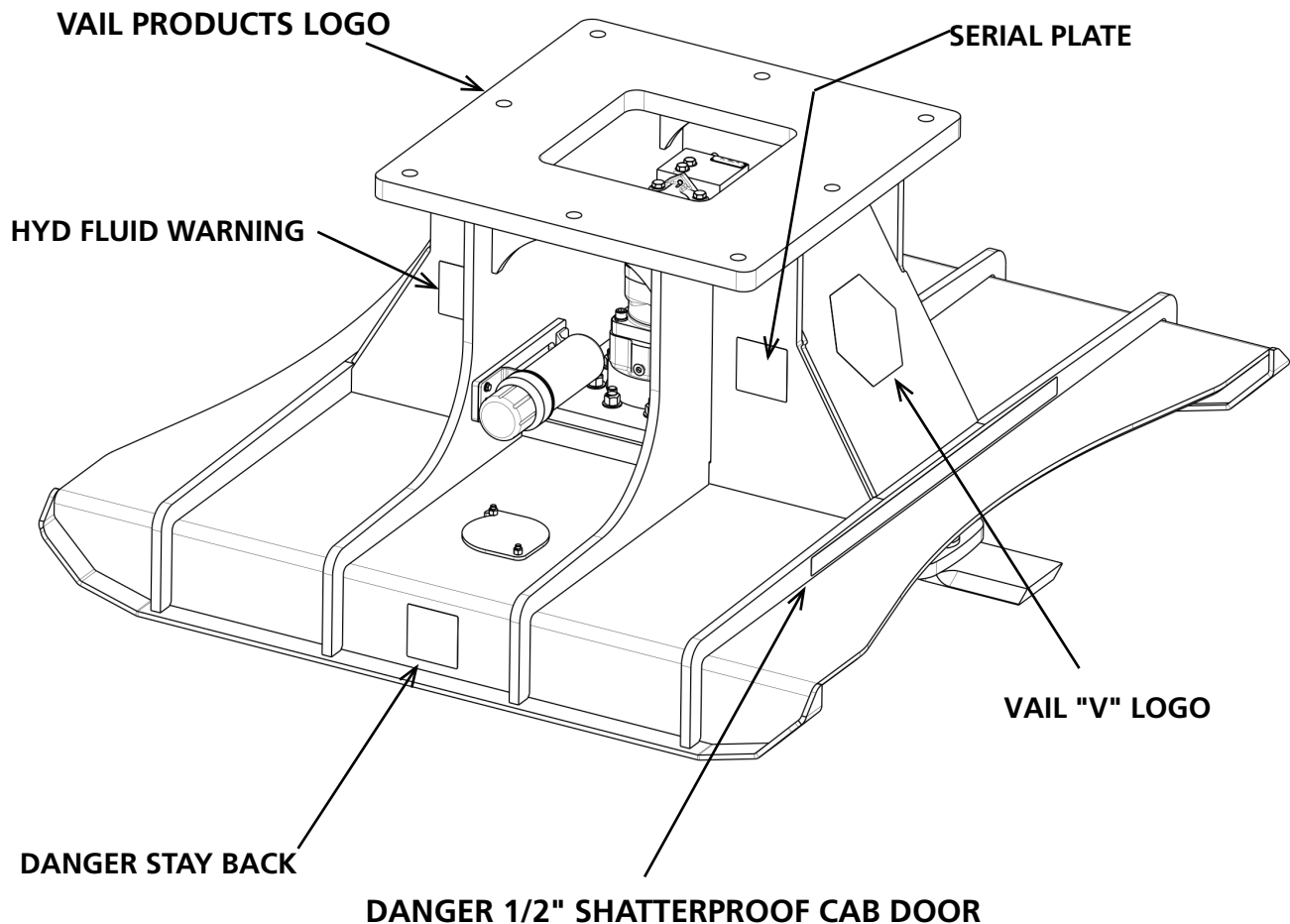

**IMPORTANT:** Keep all safety signs clean and legible. Replace all missing, illegible, or damaged safety signs. When replacing parts with safety signs attached, the safety signs must also be replaced.

**REPLACING SAFETY SIGNS:** Clean the area of application with nonflammable solvent, then wash the same area with soap and water. Allow the surface to fully dry. Remove the backing from the safety sign, exposing the adhesive surface. Apply the safety sign to the position shown in the diagram above and smooth out any bubbles.

## GENERAL INFORMATION

Your attachment is operated by the prime mover's auxiliary hydraulics and mounts to the prime mover's toolbar mechanism for easy operator hook-up.

Your prime mover/loader must have an auxiliary hydraulic system and an IMPACT-RESISTANT, SHATTERPROOF 1/2" THICK POLYCARBONATE FRONT CAB DOOR to operate the rotary cutter.



**TO AVOID SERIOUS PERSONAL INJURY OR DEATH THE Rotary Cutter MUST NOT BE ATTACHED TO ANY POWER UNIT THAT DOES NOT HAVE AN IMPACT-RESISTANT, SHATTERPROOF 1/2" THICK POLYCARBONATE FRONT CAB DOOR INSTALLED.**

## NOMENCLATURE

The purpose of this diagram is to acquaint you with the various names of the rotary cutter components. This knowledge will be helpful when reading through this manual or when ordering service parts.

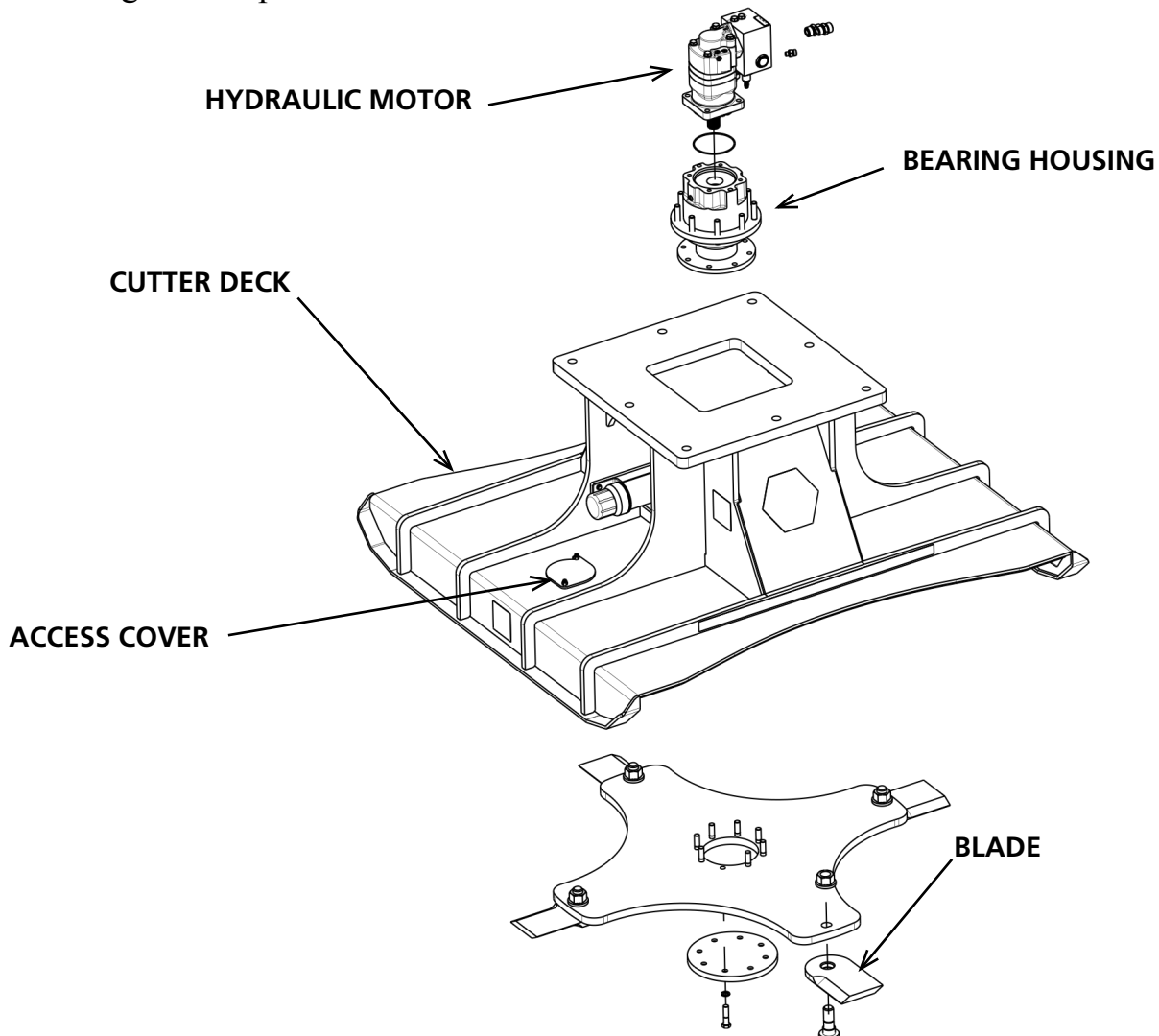

## GENERAL INFORMATION

The following instructions will help you to mount your rotary cutter onto your prime mover loader. The rotary cutter is designed for ease of installation. Therefore, if you know how to attach your loader bucket, attaching the rotary cutter should prove no problem. Remember to read all safety warnings, decals and operating instructions before operating the attachment. If there is any portion of this manual that you do not understand, contact your dealer.



**TO AVOID SERIOUS PERSONAL INJURY OR DEATH THE ROTARY CUTTER MUST NOT BE ATTACHED TO ANY POWER UNIT THAT DOES NOT HAVE AN IMPACT-RESISTANT, SHATTERPROOF 1/2" THICK POLYCARBONATE FRONT CAB DOOR INSTALLED.**

## ATTACHING TO PRIME MOVER

1. Remove any attachments from the prime mover loader.
2. Following all standard safety practices and the instructions for installing an attachment in your prime mover operator's manual, install the rotary cutter onto your prime mover loader.
3. Place the prime mover loader in non-operation mode and remove the key.
4. After making sure that there is not any foreign matter on the hydraulic couplers, connect the couplers to the auxiliary hydraulic system of your prime mover.

## DETACHING FROM PRIME MOVER

1. On firm, level ground, lower the attachment to the ground, ensure the parking brake is engaged, engine is turned off and the keys are removed.
2. Follow your prime mover operator's manual to relieve pressure in the hydraulic lines.
3. Disconnect couplers and either connect them together or install dust caps and plugs to prevent contaminants from entering the hydraulic system. Store hoses on attachment, off the ground.
4. Follow your prime mover operator's manual for detaching (removing) an attachment.

## GENERAL INFORMATION

The rotary cutter attaches to the toolbar (or quick-attach) mechanism of your prime mover loader. Due to this arrangement, thorough knowledge of the prime mover's controls is necessary for safe machine operation. Read and understand your prime mover operator's manual for information regarding prime mover operation before attempting to use the rotary cutter. Follow all installation instructions for the proper installation of the unit onto your prime mover before attempting to operate your rotary cutter.

## OPERATING TIPS

Continuous rotation of the blades is required during operation to prevent overheating of the hydraulic system. If the rotary cutter stalls, disengage auxiliary hydraulics, and remove cutter from debris before restarting.

Blade rotation is maintained by operating the attachment at pressures below relief valve settings. Overheating of the hydraulic system is caused if hydraulic oil is repeatedly forced over the relief valve



**ROTATING BLADE HAZARD! STAY BACK!**

**OBJECTS CAN BE THROWN!**

**DO NOT OPERATE NEAR BYSTANDERS.**

**DO NOT PLACE HANDS OR FEET UNDER DECK WHILE IN OPERATION OR WITH ENGINE RUNNING.**

**Due to the potential danger of flying debris, it is the owner's responsibility and is "ABSOLUTELY MANDATORY that an IMPACT-RESISTANT, SHATTERPROOF 1/2" THICK POLYCARBONATE FRONT CAB DOOR" be installed on the machine to protect the operator.**





**AVOID STALLING ROTARY CUTTER:** Continuous rotation is required to prevent overheating of the hydraulic system. Overheating of the hydraulic system is caused if hydraulic oil is repeatedly forced over the relief valve setting on either the prime mover or rotary cutter (whichever is less).

**TO RESTART BLADE ROTATION:** Disengage auxiliary hydraulics. Remove rotary cutter from debris. Engage auxiliary hydraulics to start blade rotation. (Be sure the rotary cutter is operating smoothly and at full speed, and then start forward travel.)

**REPEATED STALLING OF ROTATING BLADES:** Disengage auxiliary hydraulics. Remove rotary cutter from debris. Review operating conditions and the size/density of material being cut. Make necessary corrections. Engage auxiliary hydraulics to start blade rotation. (Be sure the rotary cutter is operating smoothly and at full speed, and then start forward travel.)

**NOTE! PURCHASE ONLY MANUFACTURER APPROVED REPLACEMENT PARTS.**

---

## TROUBLESHOOTING OPERATING CONDITIONS.

**GRASS TOO LONG OR THICK:** If cutting heavy vegetation, you may need to slow travel speed or make smaller passes (less than full cut) to prevent overloading and stalling the unit.

**BRUSH TOO BIG IN DIAMETER:** The rotary cutter is NOT designed to cut large diameter trees. If brush/trees/growth is smaller in diameter and the cutter is stalling, check the sharpness of the blades (see “Maintenance”) and cut using the procedure described earlier in this section.

**BRUSH TOO THICK OR HEAVY:** If cutting heavy or thick brush, you may need to slow travel speed or make smaller passes (less than full cut), to prevent overloading. If the blades seem to be unable to handle the volume of brush, slow down the travel speed until the unit reaches full speed before proceeding.

**SCALPING THE GROUND OR BOTTOMING OUT:** Be aware of changes in the terrain. Stay alert for drop-off’s and holes. Check the terrain and the deck position before restarting and continuing cutting.

**STRIKING FOREIGN OBJECTS:** Stay alert for rocks, fencing, abandoned wells, septic tanks or other foreign objects. If the rotary cutter comes into contact with a foreign object, stop the unit, shut off the engine and disconnect the hydraulic couplers from the prime mover. Inspect the unit and repair any damage before restarting and continuing cutting. (Never try to weld or straighten damaged blades.) Inspect the work area for any other items, and if they are too large to be removed from the area, they should be flagged clearly.



**NOTE:** When blades are bent or damaged they will become wedged on the blade carrier plate. This will cause excessive vibration and the blades must be replaced before proceeding (see “Maintenance”).

## STORAGE

The following storage procedure will help you to keep your rotary cutter in top condition. It will also help you get off to a good start the next time your cutter is needed. We therefore strongly recommend that you take the extra time to follow these procedures whenever your unit will not be used for an extended period of time.

- Clean the unit thoroughly, removing all mud, dirt, and grease.
- Sharpen or replace blades. Replace all blades at the same time and do not try to weld or straighten damaged blades; loss of integrity may result.
- Inspect for visible signs of wear, breakage, or damage. Order any parts required, and make the necessary repairs to avoid delays when starting next season.
- Tighten all loose nuts, bolts and hydraulic connections.
- Check the drive bearing housing for proper lubricant level.
- Seal hydraulic system from contaminants and secure all hydraulic hoses off the ground to help prevent damage.
- Replace decals if damaged, or in unreadable condition.
- Apply a rust-preventive spray to all moving parts and to the bottom of the deck.
- Store the unit in a dry and protected place. Leaving the unit outside will materially shorten its life.
- Touch up all unpainted and exposed areas with paint, to prevent rust.

**NOTE! PURCHASE ONLY MANUFACTURER APPROVED REPLACEMENT PARTS.**

## REMOVING FROM STORAGE

- Remove all protective coverings.
- Check hydraulic hoses for deterioration, and replace if necessary.
- Check all nuts and bolts for proper tightness, especially those securing the motor, bearing housing and blades.



**VERIFY THAT ALL TIE DOWN ACCESSORIES (CHAINS, SLINGS, ROPES, SHACKLES AND ETC.) ARE CAPABLE OF MAINTAINING ATTACHMENT STABILITY DURING TRANSPORTING AND ARE ATTACHED IN SUCH A WAY TO PREVENT UNINTENDED DISENGAGEMENT OR SHIFTING OF THE UNIT. FAILURE TO DO SO COULD RESULT IN SERIOUS PERSONAL INJURY OR DEATH.**

## TRANSPORTING

Follow all local government regulations that may apply along with recommended tie down points and any equipment safety precautions at the front of this handbook when transporting your attachment.

## GENERAL INFORMATION

Economical and efficient operation of any machine is dependent upon regular and proper lubrication of all moving parts with a quality lubricant. Neglect leads to reduced efficiency, wear, breakdown, and needless replacement of parts.

## WEEKLY CHECK

The oil level in the drive bearing housing should be checked once a week. Fill as necessary with a mild extreme pressure lubricant API-GL-5, No. 80 or 90 weight gear lubricant.

## TO CHECK:

Remove plug from rear of drive bearing housing. Lubricant should be visible.

## TO ADD:

Remove plug from rear of the drive bearing housing and add lubricant until full. Replace plug.

## DRIVE BEARING HOUSING

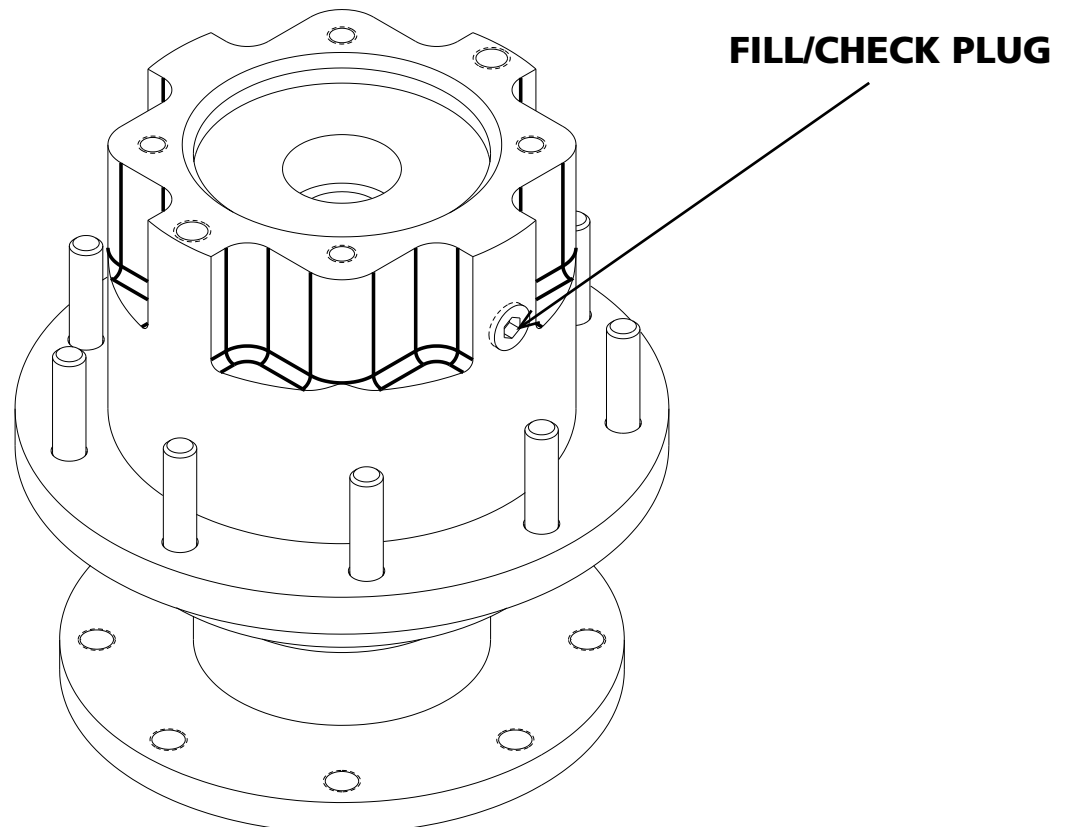

**GENERAL INFORMATION**

Regular maintenance is the key to long equipment life and safe operation. Maintenance requirements have been reduced to an absolute minimum. However, it is very important that these maintenance functions be performed as described.



**To avoid serious injury. Lower the rotary cutter to the ground, set the parking brake, stop the prime mover engine, and remove the key. Disconnect the hydraulic couplers. If unit *must* be left raised for maintenance, block the unit securely to prevent accidental release of the lifting mechanism.**

PROCEDURE	DAILY	40 HOURS	1200 HOURS
Check prime mover loader hydraulic system to ensure an adequate level of hydraulic oil.	•		
Check mounting hardware on blades and tighten if necessary. See Bolt Torque Specifications.	•		
Check all other hardware and tighten, if necessary. See Bolt Torque Specifications.	•		
Check hydraulic system for hydraulic oil leaks.	•		
Check blades for damage and replace or sharpen as needed.	•		
Check all safety guards and ensure that all devices are installed correctly.	•		
Check for missing or illegible Safety / Warning decals.	•		
Check oil level in drive bearing housing and add if necessary.		•	
Change oil in drive bearing housing.			•

**Oil Cleanliness Requirements**

**IMPORTANT:** All hydraulic fluid shall be filtered before use in product to obtain the ISO cleanliness standard of 20/18/15. Unless explicitly specified otherwise.



**Escaping fluid under pressure can have sufficient force to penetrate the skin, causing serious personal injury. Fluid escaping from a very small hole can be nearly invisible.**

**Use a piece of cardboard or wood to search for suspected leaks. See Page 8 of this manual.**

**If injured by hydraulic fluid, seek a Doctor's care immediately!**



**To avoid serious injury. Lower the rotary cutter to the ground, set the parking brake, stop the prime mover engine, and remove the key. Disconnect the hydraulic couplers. If unit *must* be left raised for maintenance, block the unit securely to prevent accidental release of the lifting mechanism.**

## REPLACING BLADES

When replacing or sharpening the blades, the unit requires blocking.

Place unit firmly on blocks and disconnect the hydraulic couplers.

The blades should be inspected regularly (every 8 hours) to ensure they are sharp, tightened correctly, intact and not wedged to the blade carrier plate. We recommend replacing all four blades at the same time and NEVER try to weld or straighten damaged blades, as loss of blade integrity may result.

1. With unit firmly on blocks and hydraulic couplers disconnected, loosen the locknuts on the access cover and rotate cover open.
2. Loosen the blade lock nuts by rotating the blade carrier until the nuts are visible in the top access opening.
3. After all nuts are loosened, position one of the nuts in the access opening and remove the nut securing the blade to the blade carrier. Remove blade and blade bolt.

Continued on page 24.

**NOTE: When replacing the blades with new ones or sharpening the blades, be sure to install the blades in the same orientation they were in when removed.**

**NOTICE: If for any reason one blade must be replaced, its best practice to replace the other blades at the same time to ensure proper balance of the blade carrier. Improper balance will cause vibration and possible component failure.**

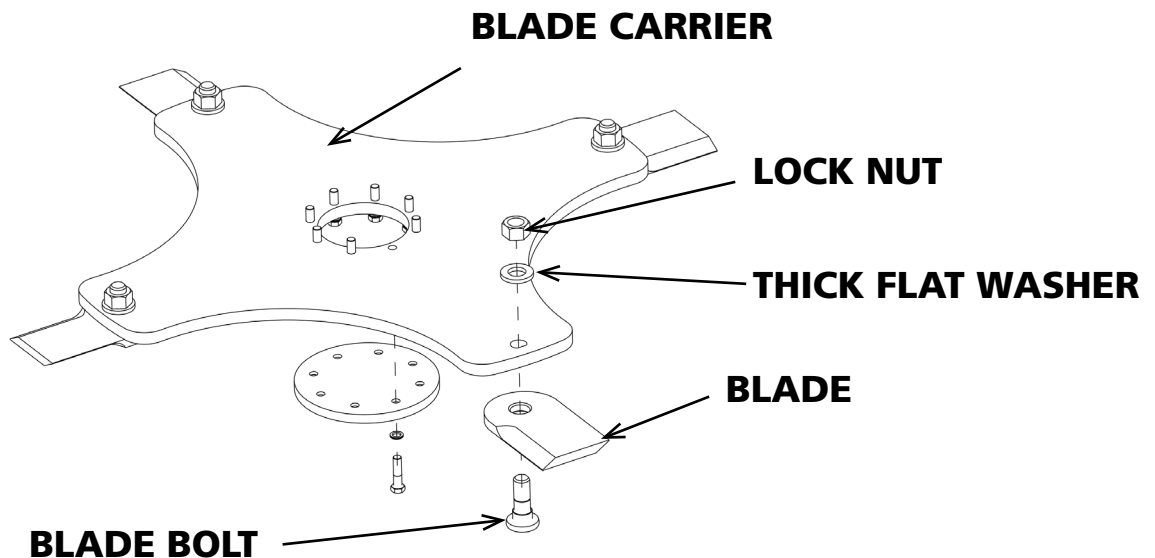

Continued from page 23.

4. Replace or sharpen blade and then loosely bolt blade into position on the carrier.  
(Install blade bolts from the bottom up, with the washer & lock nut towards the access)

**NOTE: With one hand under the blade carrier, holding the blade and blade bolt, loosely install the washer and lock nut.**

5. Repeat step #4 for the remaining blades.
6. After all blades have been replaced, torque the 1-1/4" lock nuts to **250-400 lb.-ft.** Bolt shoulder must be bottomed out on the flywheel (7 to 8 threads showing above the nut with thick washer)  
This torque range can be achieved with a 1/2" drive impact wrench (pneumatic or electric)
7. Shut access cover and tighten hardware.

### REPLACING HYDRAULIC MOTOR

When replacing the hydraulic motor the unit should be setting firmly on the ground with the hydraulic couplers disconnected. **Be sure all rotation has stopped before making any adjustments or repairs.**

**NOTE: Field replacement of the internal motor seals voids warranty.**

1. Remove ears/coupler plate. (Four bolts, nuts, washers)
2. Remove hoses from the motor, remove the fitting and check valve from motor.

Continued on page 25.

**IMPORTANT: If couplers were not disconnected prior to removing the control valve, oil will drain from the prime mover causing extensive oil loss.**

**HYDRAULIC MOTOR**

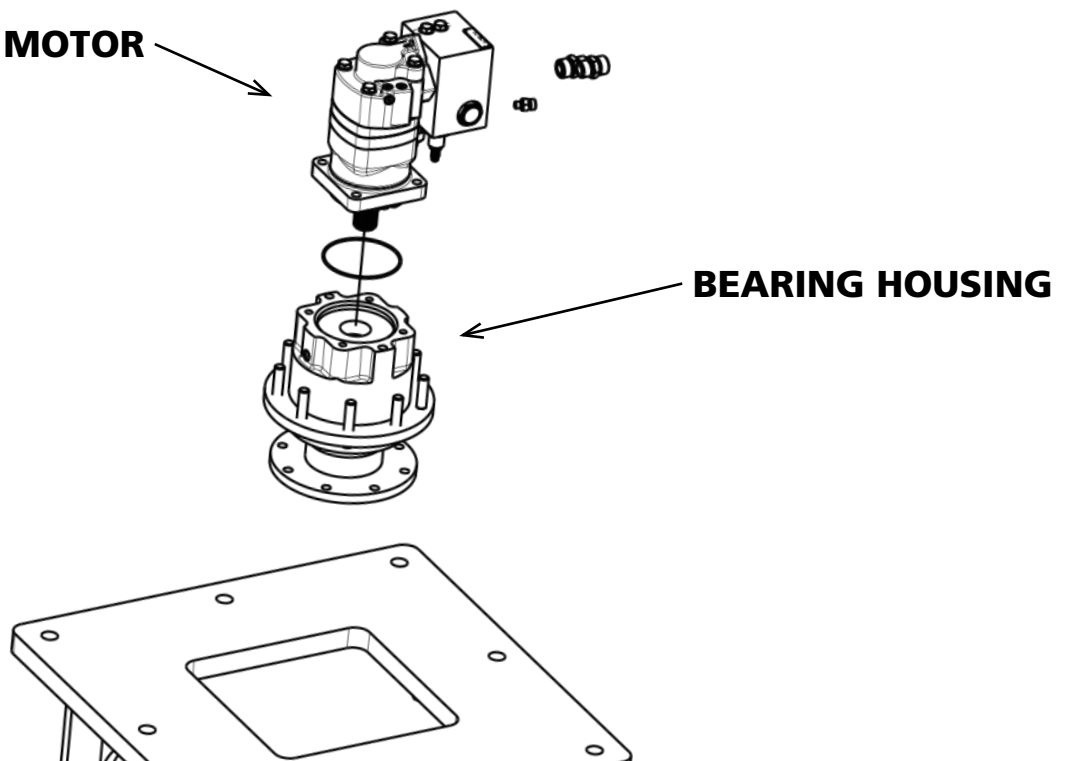



Continued from page 24.

3. Remove the capscrews holding the motor to the drive bearing housing, and remove the motor. Check motor seal (O-ring) for damage and replace if required.
4. Install the new motor with O-ring onto the drive bearing housing using the existing hardware. Torque to specifications. See Bolt Torque Specifications.
5. Re-install the fitting and check valve in their respective ports. Be sure O-Rings are properly installed on the fitting and check valve before re-installing the hoses.
6. Re-install ear/coupler plate using existing hardware and torque to specification. See Bolt Torque Specifications.

## REPLACING DRIVE BEARING HOUSING

When replacing the drive bearing housing, the unit must be detached from the prime mover in a clean, open location with a hoist available that has adequate lift capacity for lifting the attachment.

**Be sure all rotation has stopped before making any adjustments or repairs.**

1. Remove the ears/coupler plate. (Four bolts, nuts, washers.)
2. With the unit disconnected from the prime mover, attach a hoist to the cutter deck and slowly lift the rotary cutter and place it upside down with the blade carrier exposed.
3. Remove the six countersunk capscrews securing the drive bearing to the blade carrier. See diagram.
4. Attach the hoist to the blade carrier assembly and remove from the rotary cutter and set aside.  
**(NOTE: The blade carrier weighs approximately 100 lbs.)**
5. With the blade carrier assembly removed, return the unit to upright position.

Continued on page 26.

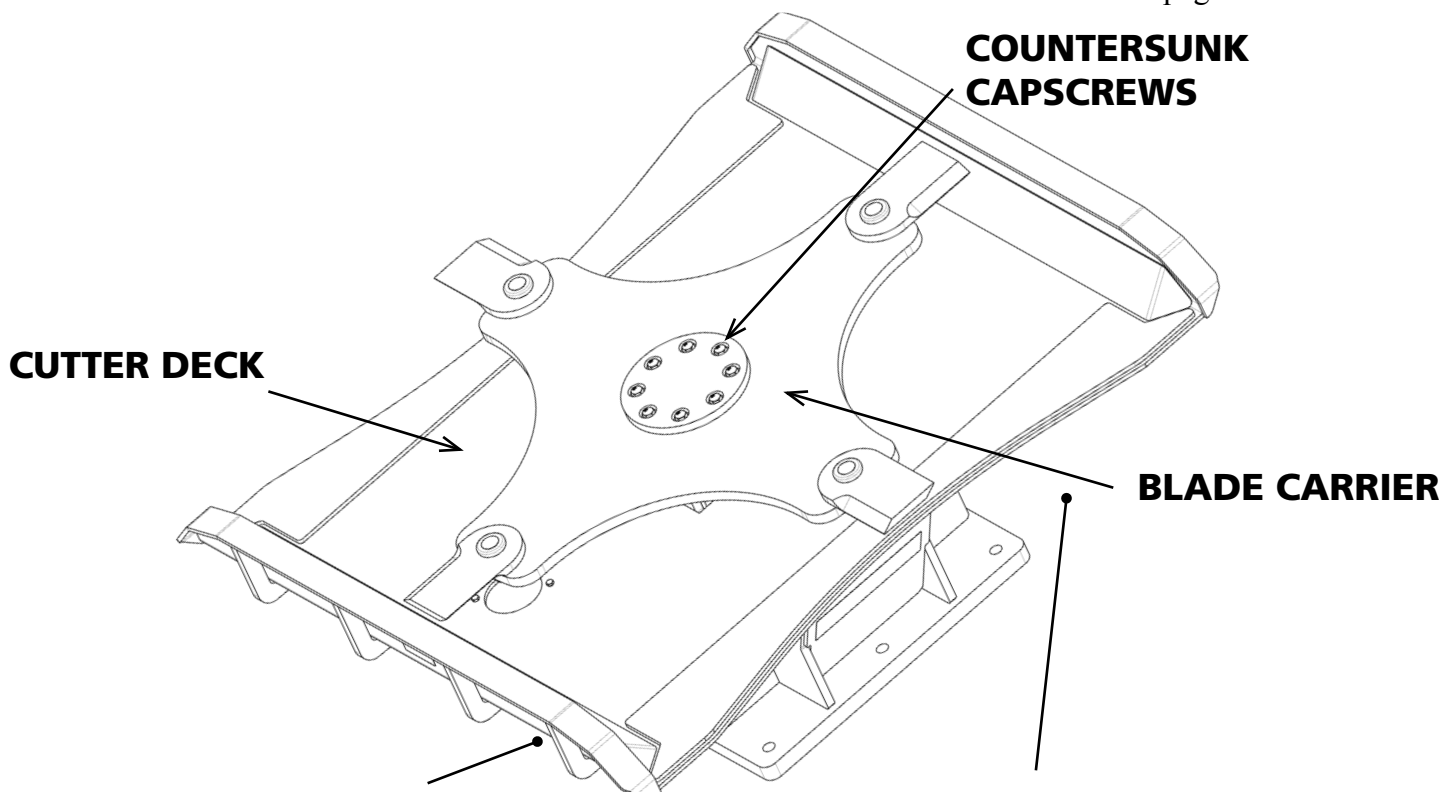

**PLACE SUPPORT BLOCKS IN THESE AREAS.  
(RECOMMENDED TO PREVENT HYD. MOTOR DAMAGE.)**

---

## REPLACING DRIVE BEARING HOUSING

Continued from page 25.

6. Remove hoses.
7. Remove the capscrews holding the motor to the drive bearing housing, and remove the motor, setting it into a clean container to help prevent any contaminants from entering the hydraulic system. Check motor O-ring for damage and replace if required.
8. Remove the capscrews securing the drive bearing housing to the cutter deck and install new housing using the existing hardware. Torque to specification. See Bolt Torque Specifications
9. Remove plugs from top of housing and fill with a mild extreme pressure lubricant API-GL-5, No. 80 or 90 weight gear lubricant. Replace plugs.
10. Install the motor assembly and O-ring onto the drive bearing housing using the existing hardware.
11. Re-install hoses, ears/coupler plate using existing hardware and torque to specification. See Bolt Torque Specifications.
12. Re-attach the hoist to the cutter deck and slowly lift the rotary cutter and place it upside down.

**NOTE: Be prepared for possible shifting of the rotary cutter as it is clears the ground. Block the cutter to ensure it is completely stable before proceeding.**

13. Attach the hoist to the blade carrier and set it into place aligning the holes on the blade carrier to the ones on the bearing housing. **(NOTE: The blade carrier weighs approximately 100 lbs.)**
14. Re-install the 6 countersunk capscrews securing the drive bearing housing to the blade carrier. Torque to specification. See Bolt Torque Specifications

Follow the installation procedure for attaching the unit onto your prime mover.

## CHANGING OIL IN DRIVE BEARING HOUSING

When changing the oil in the drive bearing housing the unit should be setting firmly on the ground with the hydraulic couplers disconnected. We recommend removing the existing oil with a fluid removal pump.

1. Remove one of the plugs in the drive bearing housing and place the extraction hose into the housing so that it reaches the bottom.
2. Place the output hose into an approved container or drum that will hold the waste oil.
3. Following the instructions for your fluid removal pump, remove all oil from the drive bearing housing.
4. Once the oil has been drained from the housing, remove the pump and refill the housing with approximately 20 ounces of a mild extreme pressure lubricant API GL-5, No. 80 or 90 weight gear lubricant.

**NOTE: Oil level should be at bottom edge of plug.**

5. Replace plug.

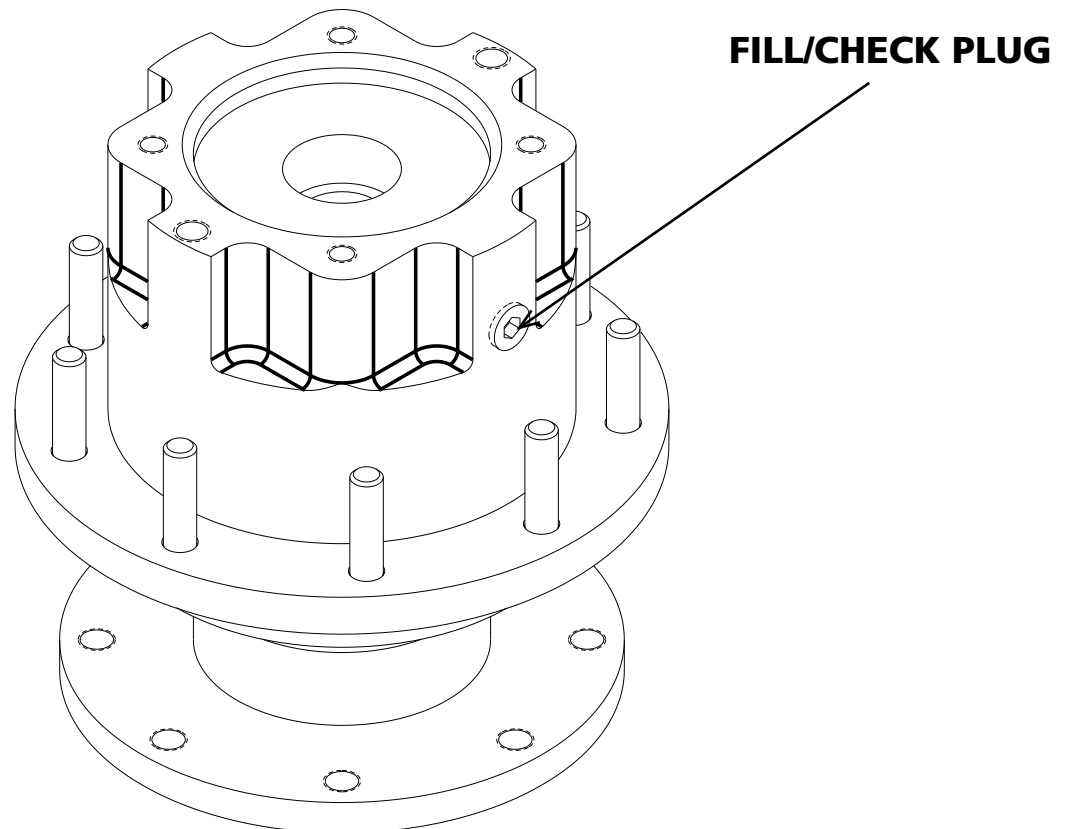



<b>PROBLEM</b>	<b>POSSIBLE CAUSE</b>	<b>POSSIBLE REMEDY</b>
<b>EXCESSIVE VIBRATION</b>	Blades bent. (Blades can become stuck to the blade carrier and cause an imbalance.)	Replace bent blades. (Blades positioned directly opposite of each other will need to be replaced at the same time.)
	Blades damaged or worn.	Replace bent blades. (Blades positioned directly opposite of each other will need to be replaced at the same time.)
	Foreign material in blade carrier assembly.	Remove any foreign material from blade carrier assembly.
<b>CUTTER STALLS TOO EASILY OR LOSS OF POWER</b>	Power and return hoses reversed.	Check flow direction and switch hydraulic couplers.
	Bearing failure. (To diagnose bearing failure; rotate blade carrier slowly and listen for bearing noise. Bearing failure will reduce power available to function correctly.)	Replace drive bearing housing.
	Foreign material in blade carrier assembly.	Remove any foreign material from blade carrier assembly.
	Imbalance of blade carrier assembly.	Check excessive vibration section for possible causes and remedies.
	Control valve cartridge or O-ring failure.	Replace as required.

## GENERAL TORQUE SPECIFICATION TABLES

Use the following charts when determining bolt torque specifications when special torques are not given. Always use grade 5 or better when replacing bolts.

### SAE BOLT TORQUE SPECIFICATIONS

**NOTE: The following torque values are for use with extreme pressure lubricants, plating or hard washer applications. Increase torque 15% when using hardware that is un-plated and either dry or lubricated with engine oil.**

BOLT SIZE		SAE GRADE 5 TORQUE				SAE GRADE 8 TORQUE				Bolt head identification marks as per grade. NOTE: Manufacturing marks will vary.
		Pounds Feet		Newton-Meters		Pounds Feet		Newton-Meters		
Inches	Millimeters	UNC	UNF	UNC	UNF	UNC	UNF	UNC	UNF	
1/4	6.35	8	9	11	12	10	13	14	18	GRADE 2 
5/16	7.94	14	17	19	23	20	25	27	34	
3/8	9.53	30	36	41	49	38	46	52	62	
7/16	11.11	46	54	62	73	60	71	81	96	
1/2	12.70	68	82	92	111	94	112	127	152	
9/16	14.29	94	112	127	152	136	163	184	221	GRADE 5 
5/8	15.88	128	153	174	207	187	224	254	304	
3/4	19.05	230	275	312	373	323	395	438	536	
7/8	22.23	340	408	461	553	510	612	691	830	
1	25.40	493	592	668	803	765	918	1037	1245	
1-1/8	25.58	680	478	922	1014	1088	1224	1475	1660	
1-1/4	31.75	952	1054	1291	1429	1547	1700	2097	2305	GRADE 8 
1-3/8	34.93	1241	1428	1683	1936	2023	2312	2743	3135	
1-1/2	38.10	1649	1870	2236	2535	2686	3026	3642	4103	

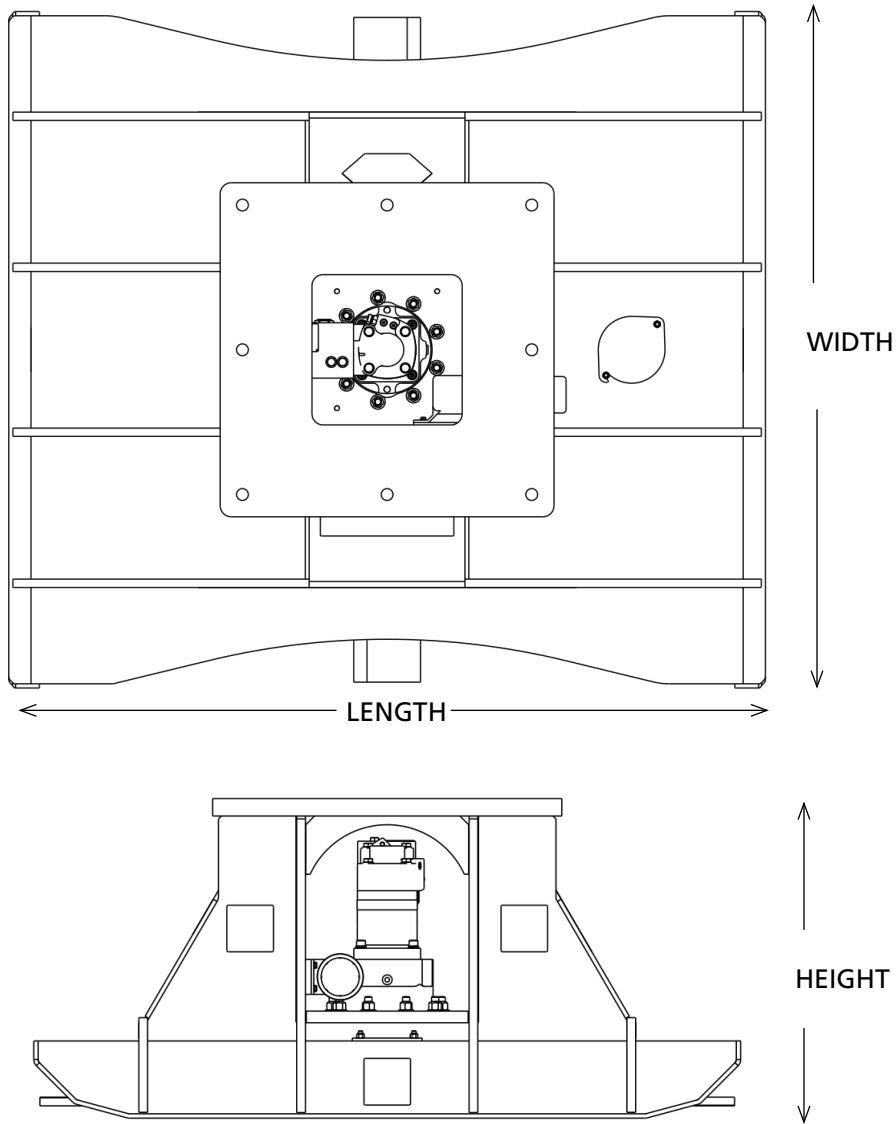

MODEL	XBC-EX-6820	XBC-EX-7820
WIDTH	60 in. (1524 mm)	71 in. (1797 mm)
LENGTH	68 in. (1727 mm)	78 in. (1981 mm)
HEIGHT	28 in. (697 mm)	28 in. (697 mm)
WEIGHT	2500 lbs.** (1134 kg)	3000 lbs.** (1360 kg)
SWATH	60 in. (1524 mm)	72 in. (1829 mm)
FLOW	30-40 gpm (40 gpm MAX)	30-40 gpm (40 gpm MAX)
OPERATING MACHINE WEIGHT	25,000-75,000 lbs. (11,340-34,019 kg)	30,000-75,000 lbs. (13,608-34,019 kg)
BLADES	4	4

\*\*with coupler

## 68" & 78" Deck

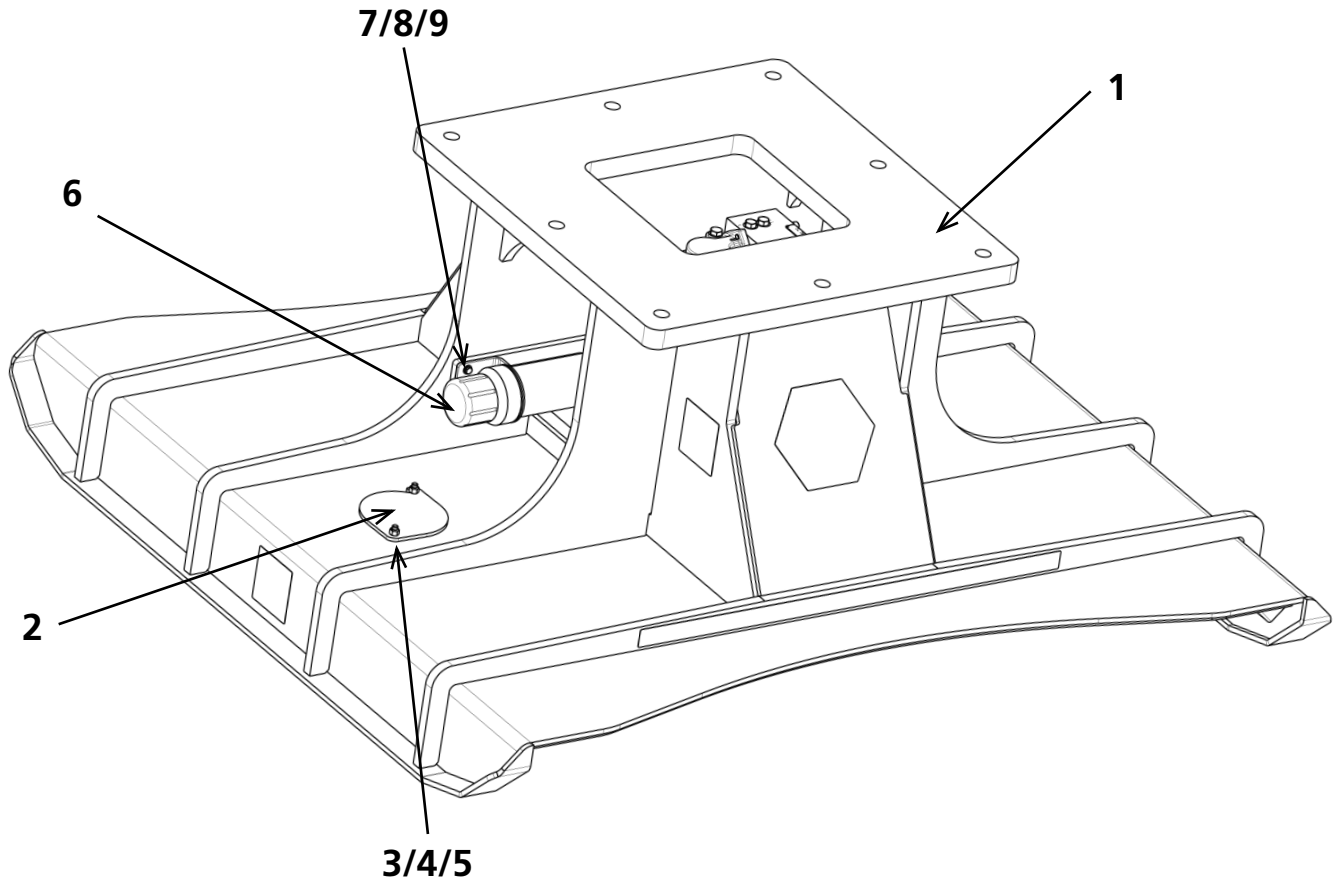

ITEM	PART #	DESCRIPTION	QTY
1	50200935	Cutter Deck Weldment 68"	1
	50200940	Cutter Deck Weldment 78"	
2	51050000	Access Cover	1
3	51090400	3/8"NC x 1-1/4" Hex Cap Screw Gr.5	2
4	51090500	3/8" SAE Flat Washer	4
5	51090600	3/8" Lock Nut	2
6	59999000	Manual Canister	1
7	52093500	1/4" SAE Flat Washer	3
8	53093300	1/4" x 3/4" Hex Cap Screw Gr.5	3
9	52093040	1/4" Lock Washer	3

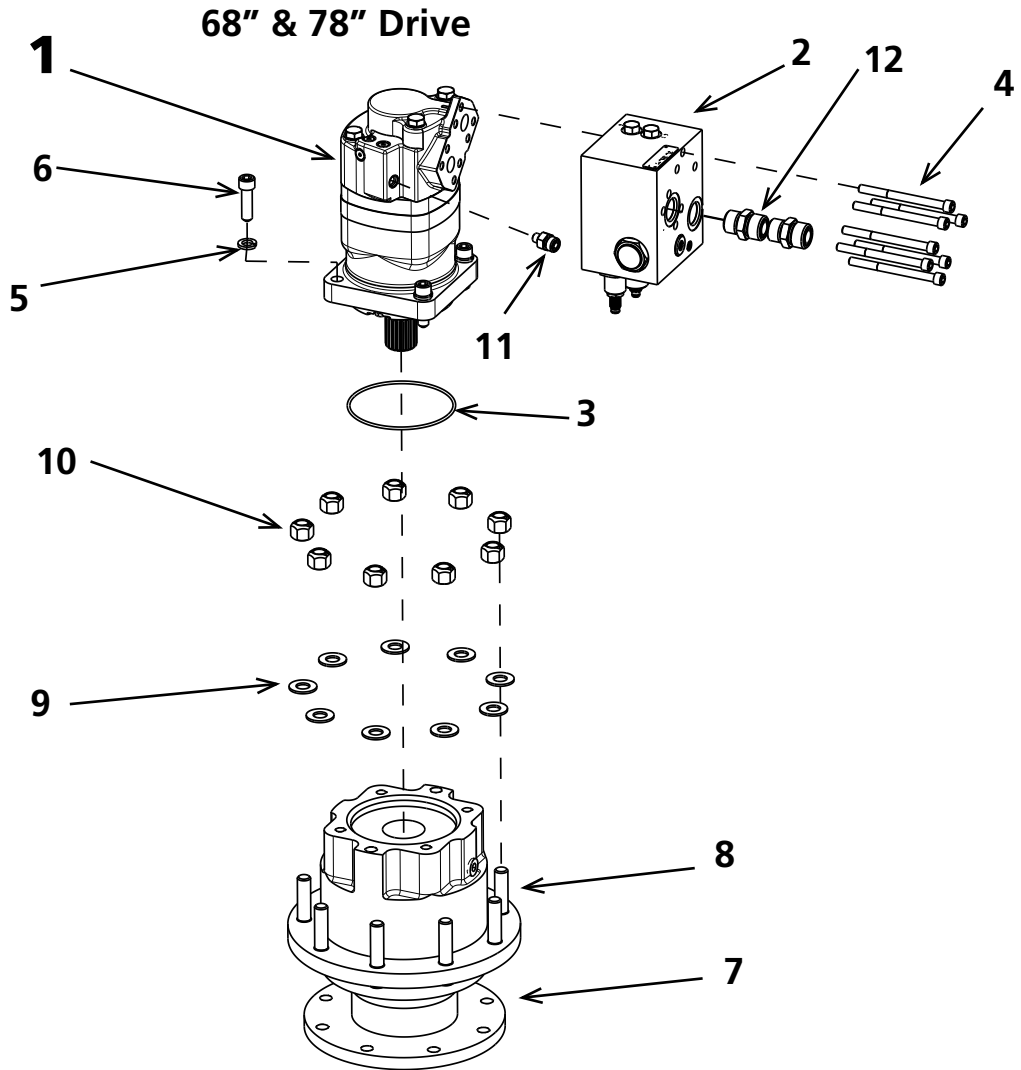

ITEM	PART #	DESCRIPTION	QTY
<b>51991000</b>		The following items ( 1 thru 6 ) are included in the Motor Kit (Specify High Flow or Low Flow Motor)	
1	51060000	Hydraulic Motor (High Flow)	1
	51060040	Hydraulic Motor (Low Flow) 25 GPM Max	
2	51060200	Hydraulic Valve Body	1
3	51060500	O-Ring (Under Motor)	1
4	51090100	3/8"NC x 4-1/2" Socket Cap Screw	7
5	52093060	1/2" Lock Washer (Nord-Lock)	4
6	52093200	1/2"NC x 1-3/4" Socket Cap Screw	4
7	51060100	Drive Bearing	1
8	51091300	5/8"-18 UNF x 3" Stud	
9	51090900	5/8" SAE Flat Washer	9
10	51090610	5/8"-18 UNF TopLock Nut Gr.C	
11	51060700	Hydraulic Fitting, Case Drain, -04 MBo x -06 ORFS	1
12	51060600	Hydraulic Fitting, Supply, -12 MBo x -12 ORFS	2



## 68" & 78" Drive

### HYDRAULIC SYSTEM AND HOSE CONNECTION DETAIL

40 GPM MAXIMUM

MOTOR MANIFOLD  
PRESSURE RELIEF VALVE  
IS FACTORY SET AT 3000 PSI

CASE DRAIN CONNECTION  
-06 MALE ORFS

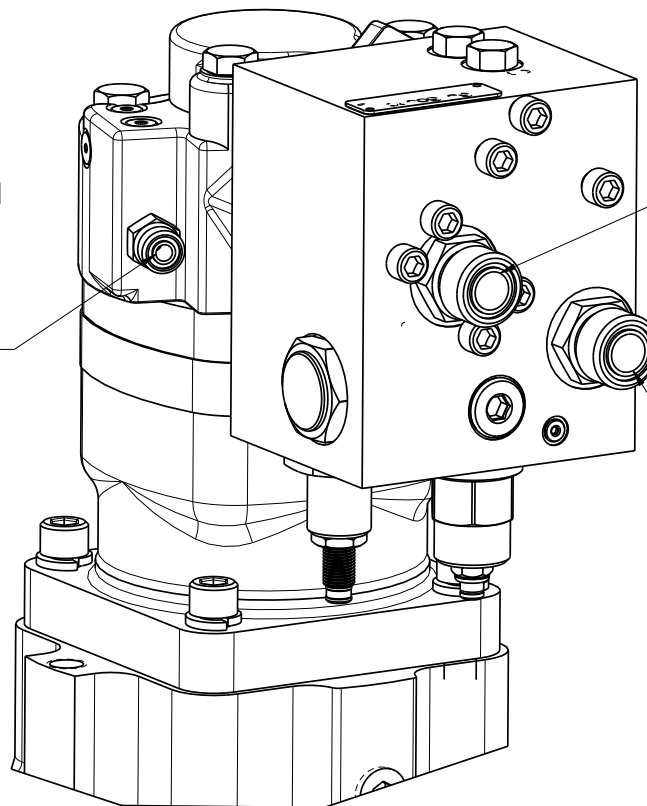

INLET CONNECTION  
-12 MALE ORFS

OUTLET CONNECTION  
-12 MALE ORFS

68" & 78" Blade Carrier

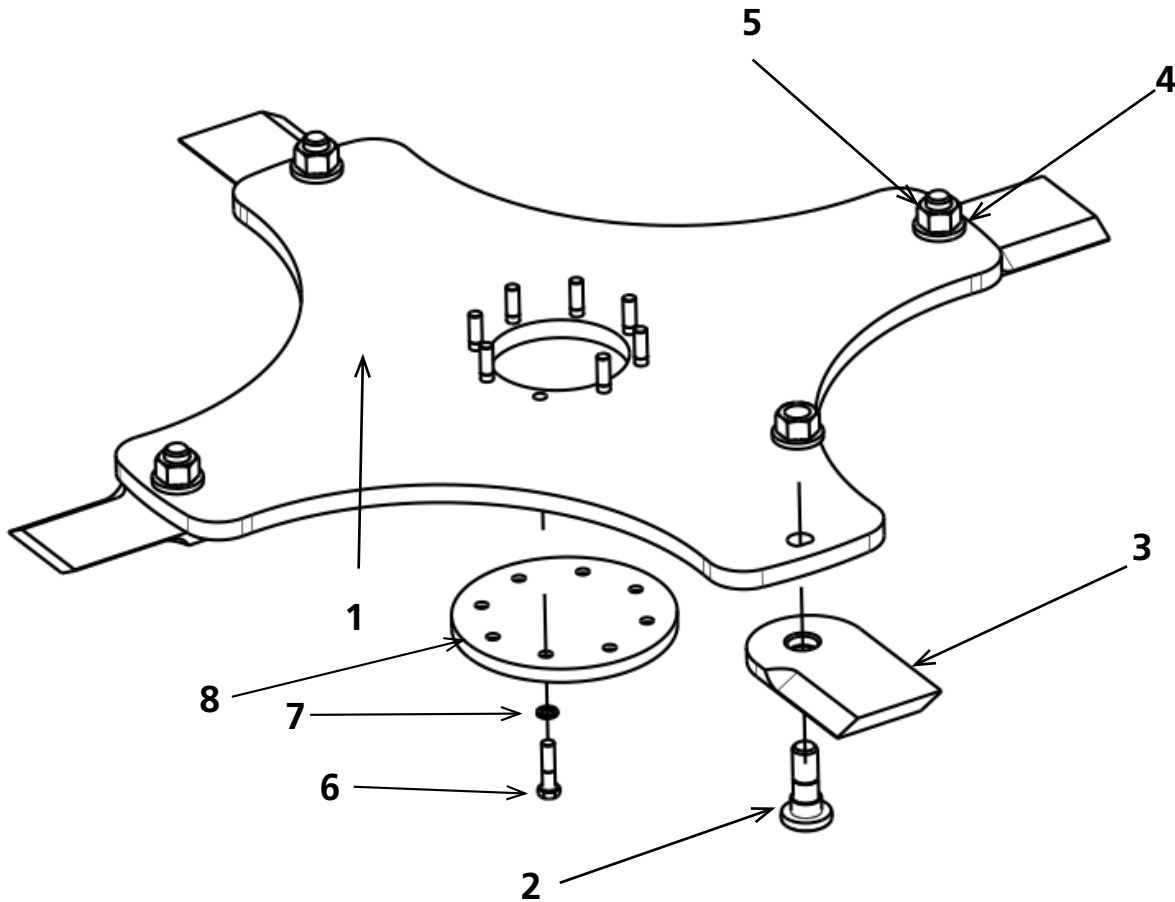

ITEM	PART #	DESCRIPTION	QTY
1	50200945	Blade Carrier - 68"	1
	50200950	Blade Carrier - 78"	
2	51425200	Blade Bolt	4
3	51425300	Blade, 3/4" Thick - Reversible	4
4	51091150	1-1/4" Thick Flat Washer	4
5	51090650	1-1/4" UNF Lock Nut	4
6	51090700	5/8" UNF x 2 1/2" Hex Cap Screw Gr. 9 (Torque to 239 lb/ft)	8
7	51090800	5/8" Lock Washer (Nord-Lock)	8
8	51040000	Retainer Plate	1



# Limited Warranty

## U.S. WARRANTY

Vail Products equipment are warranted against any defect in material and workmanship for a period of twelve (12) months for hydraulics and thirty six (36) months for structural components from date of shipment when properly installed, maintained and operated within the limits of normal usage. This warranty does not extend to products subject to misuse, neglect, vandalism, accidents or alterations to the original design. Liability, if any, is limited to replacement parts or material found to be defective, that will be furnished free of charge and shipped by transportation of our choice, F.O.B., our shop. No allowance or claim of any nature will be paid resulting from alterations or repairs of the product, including labor, and in no event shall seller be liable for any special, contingent or consequential damages. In all cases, full opportunity is to be given for investigation by seller's representative, before warranty is authorized. No goods shall be returned except by written permission of seller, and returns under any other conditions will not be accepted. VAIL PRODUCTS will not be responsible for any import taxes or duties imposed by other governments or governmental agencies. SAID WARRANTY IN RESPECT OF REPLACEMENT OF DEFECTIVE PARTS AND ANY SUCH ADDITIONAL WARRANTY OR REPRESENTATION EXPRESSLY MADE A PART HEREOF ARE IN LIEU OF ALL OTHER WARRANTIES EXPRESS OR IMPLIED, INCLUDING ANY IMPLIED WARRANTY OF MERCHANTABILITY FOR FITNESS OF PURPOSE. Where you are a distributor, financing company or similar entity acting for or on behalf of the initial user of the equipment, the warranty is transferable to initial user only. In all other cases the warranty is limited to you and is not transferable. For products not supplied by the seller's licensed manufacturer, it extends to the buyer the warranties of the manufacturer only.

## INTERNATIONAL WARRANTY

Vail Products equipment are warranted against any defect in material and workmanship for a period of six (6) months for hydraulics and twelve (12) months for structural components from date of shipment for products that are properly installed, maintained and operated within the limits of normal usage. This warranty does not extend to products subject to misuse, neglect, vandalism, accidents or alterations to the original design. Liability, if any, is limited to replacement parts or material found to be defective, that will be furnished free of charge and shipped by transportation of our choice, F.O.B., our shop. No allowance or claim of any nature will be paid resulting from alterations or repairs of the product, including labor, and in no event shall seller be liable for any special, contingent or consequential damages. In all cases, full opportunity is to be given for investigation by seller's representative, before warranty is authorized. No goods shall be returned except by written permission of seller, and returns under any other conditions will not be accepted. VAIL PRODUCTS will not be responsible for any import taxes or duties imposed by other governments or governmental agencies. SAID WARRANTY IN RESPECT OF REPLACEMENT OF DEFECTIVE PARTS AND ANY SUCH ADDITIONAL WARRANTY OR REPRESENTATION EXPRESSLY MADE A PART HEREOF ARE IN LIEU OF ALL OTHER WARRANTIES EXPRESS OR IMPLIED, INCLUDING ANY IMPLIED WARRANTY OF MERCHANTABILITY FOR FITNESS OF PURPOSE. Where you are a distributor, financing company or similar entity acting for or on behalf of the initial user of the equipment, the warranty is transferable to initial user only. In all other cases the warranty is limited to you and is not transferable. For products not supplied by the seller's licensed manufacturer, it extends to the buyer the warranties of the manufacturer only.

# **OWNER'S MANUAL**

**MUST STAY WITH PRODUCT**