

Front Suspension:

Ride Height: _____
 Camber: _____
 Toe: _____
 Anti-Roll Bar: _____
 Arm Type: _____
 Tower Type: _____
 Wheel Hex: _____
 Steering Block: _____
 Caster Block Insert: _____
 Bulkhead Type: _____
 Kick-Up Angle: _____
 Notes: _____

Bump Steer Spacing: _____

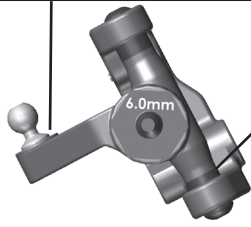

Axle Height:

+3
 +2
 +1
 0

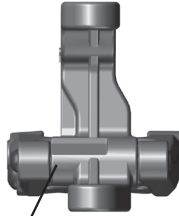

Caster Block Spacing: _____

Ball Stud Spacing: _____

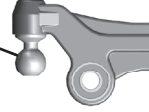

Ball Stud Spacing: _____

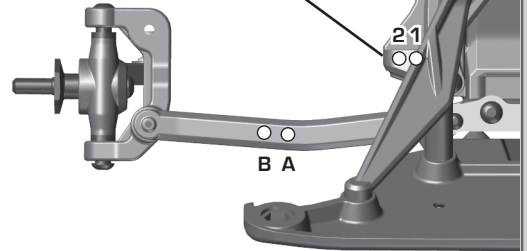

Rear Suspension:

Ride Height: _____
 Camber: _____
 Anti-Roll Bar: _____
 Arm Type: _____
 Tower Type: _____
 Arm Spacing: _____
 Wheel Hex: _____
 Shock Mounting Position:
 Front of Arm Rear of Arm
 Hub Spacing: Fwd Mid Back
 Notes: _____

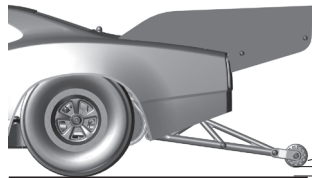
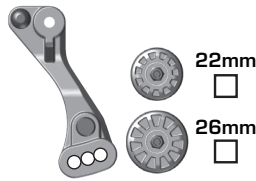

Wheelie Bar Position: _____

Ball Stud Spacing: _____

Ball Stud Spacing: _____

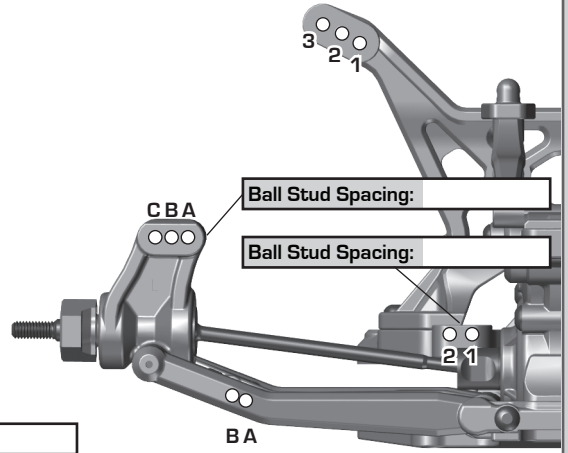

Electronics:

Radio: _____ Servo: _____
 EPA: Throttle: _____ % Brake: _____ %
 ESC: _____
 ESC Settings: _____
 Motor: _____
 Wind: _____ Timing: _____
 Pinion: _____ Spur: _____
 Battery: _____
 Battery Position: _____
 Battery Weight: _____

Drivetrain:

Differential: _____ Ball Diff:
 Diff Fluid: _____ Gear Diff:
 Notes: _____

Slipper Clutch:

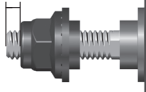
Type: _____
 # of Pads: _____
 Setting: _____

 Notes: _____

Shocks:

	Front	Rear
Piston:	_____	_____
Fluid:	_____	_____
Spring:	_____	_____
Limiters:	Int: _____ Ext: _____	Int: _____ Ext: _____
Stroke:	_____	_____
Eyelet Length:	_____	_____
Cup Offset:	_____	_____
Notes:	_____	



Track Info:

Burnout: Yes No Length: _____
 Burnout Surface: _____
 Surface: Asphalt Concrete Prep No-Prep
 Traction: Low Medium High Very High
 Temperature: Ambient: _____ Track: _____
 Tire Warmers: Yes No Time: _____ Temp: _____
 Notes: _____
 Vehicle Comments: _____

Tires:

Front Tires: _____
 Front Compound: _____
 Front Insert: _____
 Rear Tires: _____
 Rear Compound: _____
 Rear Insert: _____
 Wheel (F/R): _____
 Notes: _____

Body, Weight:

Body: _____
 Body Height: Front: _____ Rear: _____
 Servo Weights: _____
 Electronic Weights: _____
 Vehicle Weight: Front: _____ Rear: _____
 Total Vehicle Weight: _____
 Notes: _____