

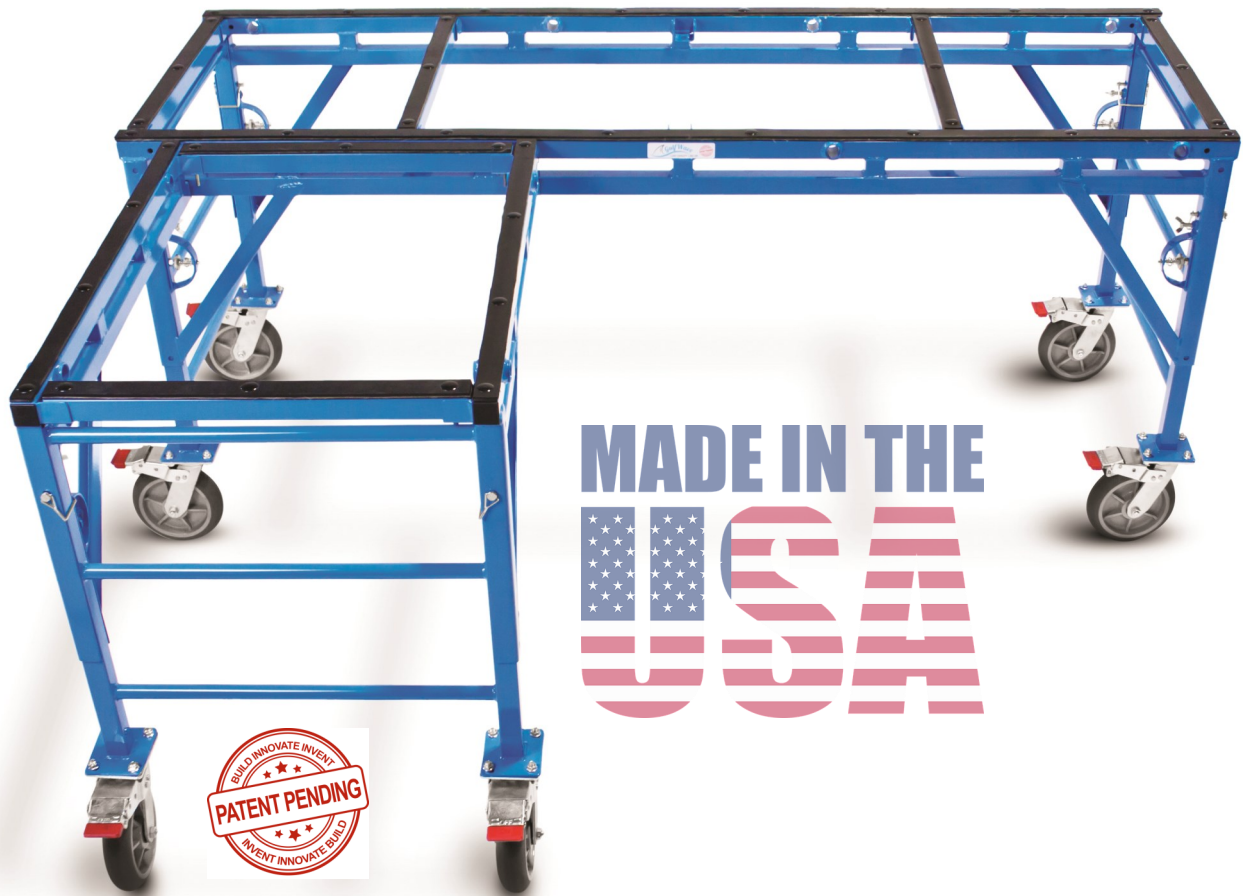

UNRIVALED QUALITY AND CRAFTSMANSHIP



MADE IN THE
A graphic of the United States flag, with the letters "USA" in a large, stylized font. The "U" and "A" are white with red outlines, and the "S" is white with red and blue outlines. The background is a red and white striped pattern.



***MATERIAL HANDLING EQUIPMENT
DESIGNED FOR THE STONE FABRICATOR***



MODULAR FABRICATION WORK TABLE -- ASSEMBLES IN JUST ONE MINUTE

A WHALE OF A TABLE!

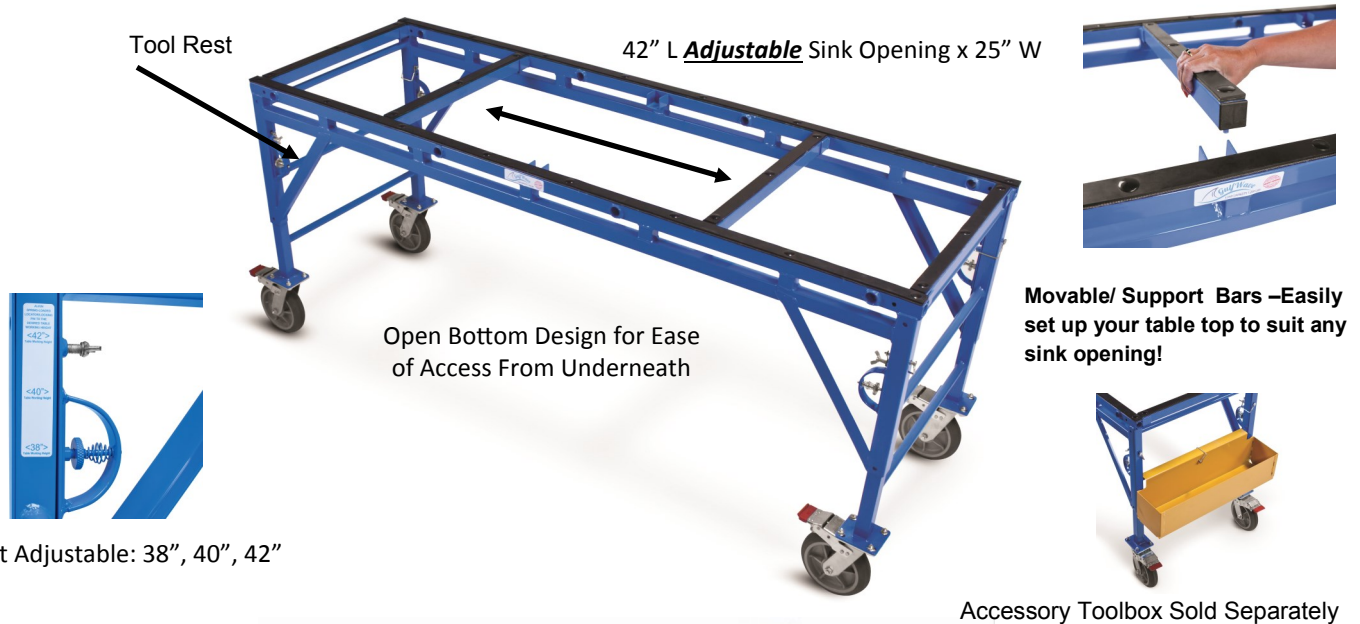

Accessory Toolbox Sold Separately

MODULAR FABRICATION WORK TABLE: MODEL NO. GWT-8428

- Patent Pending Modular Design - Easily Assembled by One Person in a Matter of Minutes
- Once Casters Installed - NO TOOLS NEEDED FOR ASSEMBLY
- Height-Adjustable to 38", 40" and 42" for Ergonomic Comfort - One Person Can Adjust Height w/No Tools
- Spring-Loaded, Height-Aligning Locking System - Zinc Coated for Rust Resistance
- Secondary Safety Hook Pin for Added Security Once Height is Adjusted
- Double-Bar Steel Design to Prevent Bowing
- Heavy Duty Industrial-Strength Rubber Guards on Top Surface for Stone Protection
- Specialty Fasteners Used to Attach Rubber Guards to the Frame for Easy-Glide and Anti-Scratch
- 4 Squaring Pegs/Stiffening Compression Screws
- Electrostatic Powder Coating Provides a Long-Lasting, Scuff-Resistant Finish
- 4 8" Heavy Duty Total Lock Casters for Easy Maneuverability - Locks Both Swivel and Roll
- Breaks Down for Easy Storage - Just 5" High When Broken Down and Laid Flat
- 4 Support Bars that are Movable to Accommodate Sink Openings
- Open Bottom Design for Ease of Access to Work From Underneath
- Tool Rest for Quick Storage and Handy Re-Use - Saves Wear and Tear on Tools
- Replaceable Parts: Protectant Pad, Casters, Table Ends, Table Sides, Support Bars, Safety Hook Pins and Positive Engagement Locks

YOU'VE NEVER SEEN ANYTHING QUITE LIKE THIS!

SPECS:

- Load Capacity: 1,200 lbs.
- Dimensions: 84" L x 28" W (Ext. Frame) or 25" W (Int. Frame)
- Height: Adjustable to 38", 40" or 42" (w/casters)
- Weight: 128 lbs. (w/casters)



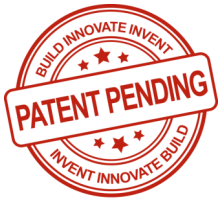

And now for —

THE WHALE'S TAIL!

A Modular Component

**All the Same Features of the Whale of a Table -
When Used Together, the Possibilities Are Endless!**

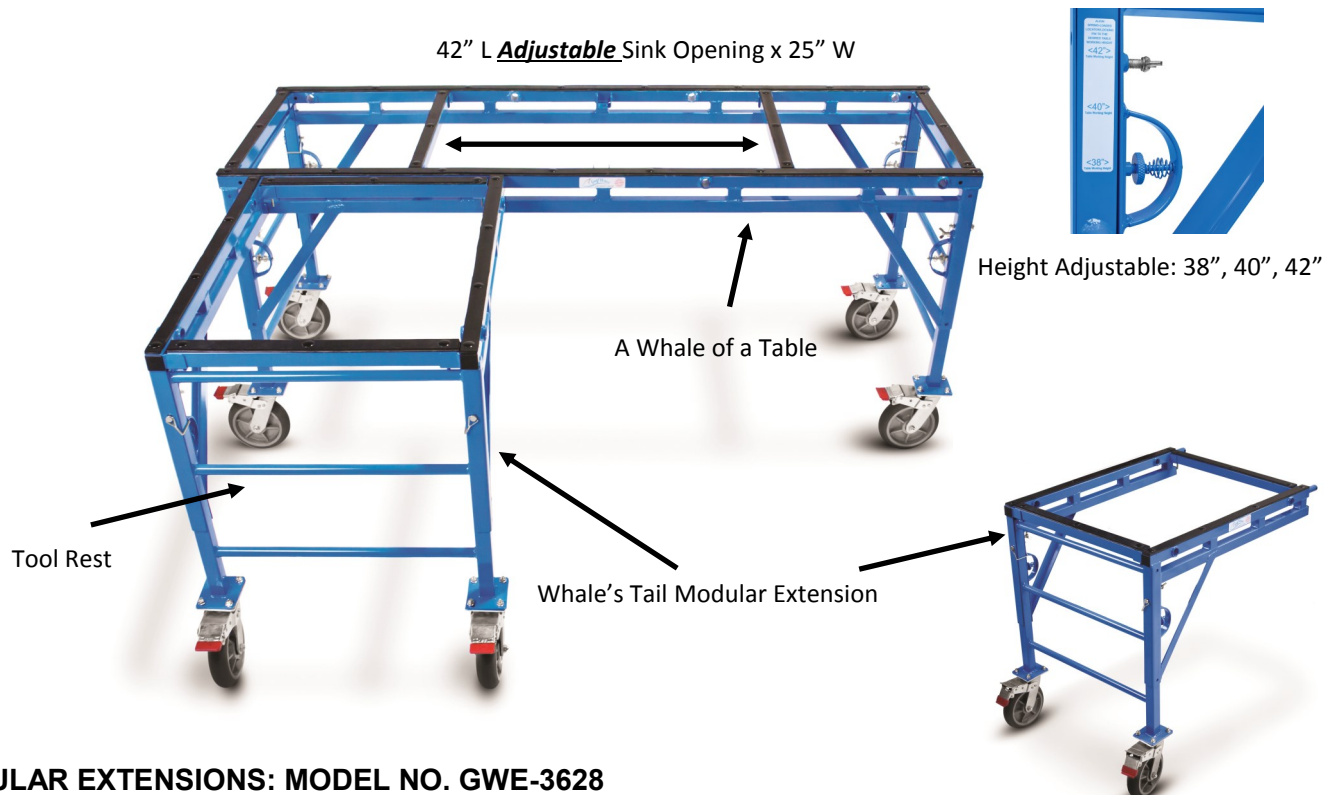

MODULAR EXTENSIONS: MODEL NO. GWE-3628

- 3' Extension Available to Create Additional Work Space When Used with a Whale of a Table - Lengthen Table or Form an L-Shape, U-Shape or even a Z-Shaped Work Surface
- All of the Same Features as the Whale of a Table
- Add as Many Extensions as Needed for Length or Shape - All Extensions are Interchangeable With Both the Table and With Other Extensions
- Extension Also Breaks Down for Easy Storage - Just 5" High When Broken Down and Laid Flat
- All Extensions Come with Squaring Pegs/Stiffening Compression Screws
- 2 8" Heavy Duty Total Lock Casters for Easy Maneuverability - Locks Both Swivel and Roll
- Replaceable Parts: Protectant Pad, Casters, Table Ends, Extension Sides, Support Bars, Safety Hook Pins and Positive Engagement Locks

SPECS:

- Load Capacity: 1,200 lbs. (when used with table)
- Dimensions: 36-1/4" L x 28" W (Ext. Frame) or 25" W (Int. Frame)
- Height: Adjustable to 38", 40" or 42" (w/casters)
- Weight: 63 lbs. (w/casters)



Stackable to Just 5" High When Lying Flat

**Short of Space? This Modular Table and Extensions
Break Down for Easy Storage When Not in Use!**

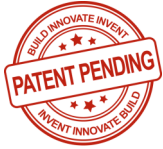

Moveable Support Bars

**Easily Set Up Your Table to Suit ANY Needed Opening AND
Open Bottom Design Makes Working Underneath Simple!**



Easy Assembly Videos On Our Website

One Whale of a Table and One Whale's Tail Modular Component shown below:



Lengthen the Whale of a Table with a
Whale's Tail to create additional 3' of work space
(Table may be lengthened w/Several Extensions, if needed)



Need an L-Shaped work space?
(U-Shapes may also be created with Two
Whale's Tails)

Photos depict just a couple of the countless configuration options

Component parts are

INTERCHANGEABLE and REPLACEABLE!

(Using Only Gulf Wave Component Parts)

BLUE MARLIN TABLE

IT'S SLEEK AND FIERCE!



**Boltless Casters—
Installed w/Stem and
Snap Ring**

**Only 3 Pieces and
No Tool/No Bolt Assembly**

**ASSEMBLES IN JUST ONE MINUTE WITH 3 SIMPLE PIECES
NO TOOLS OR BOLTS NEEDED**

THE BLUE MARLIN TABLE: MODEL NO. GWT-BM8728

- Assembles in Just One Minute
- 3/16" Thick Steel Longitudinal Runners for Strength
- 4 5" Blue Non-Marking Thermoplastic Rubber Tread, Total Lock, Stem-Style Casters with Snap Rings -- Locks Both Swivel and Roll; **NO BOLT INSTALLATION**
- Breaks Down for Easy Storage - Just 7" High When Broken Down and Laid Flat
- Open Bottom Design for Ease of Access to Work From Underneath
- 4 Safety Lock Pins for Added Security
- Heavy Duty Industrial Strength Rubber Guards on Top Surface for Stone Protection
- 8 Squaring Pegs/Stiffening Compression Screws
- 42" L x 24" W Sink Opening
- Electrostatic Powder Coating Provides a Long Lasting, Scuff Resistant Finish
- Tool Rest for Quick Storage and Handy Re-Use -- Saves Wear and Tear on Tools
- Replaceable Parts: Heavy Duty Industrial Rubber Surface Padding; Casters; Table Ends; Table Top; and Lock Pins
- Available Accessories: Boxfish Tool Box

SPECS:

- Load Capacity: 1,000 lbs.
- Dimensions: 87" L x 28" W x 40" H (w/casters)
- Weight: 138 lbs.

SHOP CARTS

All Gulf Wave Shop Carts Feature:

- 1) Completely Welded, Unitized Tubular Steel Frames for Strength; and
- 2) A Convenient Welded Project Clipboard

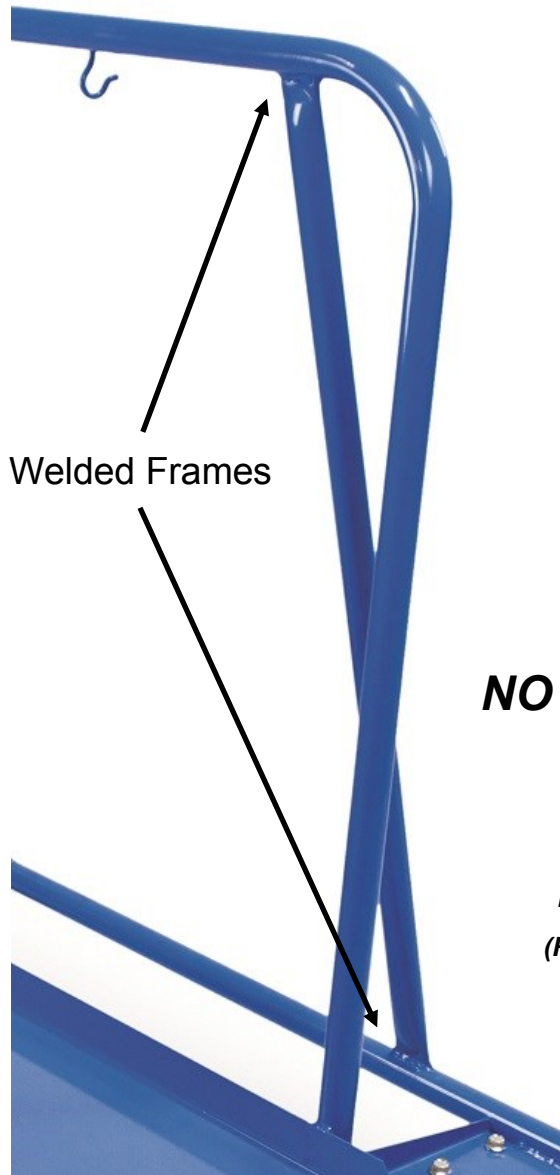

***NO CART FRAME ASSEMBLY REQUIRED
ON ANY GULF WAVE SHOP CART***

REPLACE THE PARTS, NOT YOURS CARTS!

(Replacement casters, padding and upright protectors available)

Deluxe Carts Also Include:

- 1) Pre-Installed Industrial Rubber Padding on Cart Pans; and
- 2) Heavy-Duty Compression Fit Upright Protectors



COMPRESSION FITTING INCLUDED



TAKE A BITE OUT OF THOSE HEAVY-DUTY JOBS!

SHARK CART - DELUXE



DELUXE SHARK CART: MODEL NO. GWC-S1948D

- Completely Welded, Unitized Tubular Steel Frame
- Electrostatic Powder Coating Provides a Long-Lasting, Scuff-Resistant Finish
- Large Wheel Base for Stability that will bear weight up to 3,200 lbs.
- 2 8" Hi-Tech Silverline Swivel Casters
- 2 8" Hi-Tech Silverline Swivel Casters with Wheel Lock
- Heavy Duty Compression Fit Upright Protectors—Installed
- Heavy Duty Industrial Strength Rubber Protectant Pad for Cart Pan—Installed

Carts That Will Last for Years!

SHARK CART - STANDARD

STANDARD SHARK CART: MODEL NO. GWC-S1948S

All the Same Great Features Above, Without the Rubber Padding and Compression Fit Upright Protectors

SHARK CART SPECS:

- Load Capacity: 3,200 lbs.
- Platform Dimensions: 48" L x 19" W
- Overall Dimensions: 48" L x 29.25" W x 47" H (w/casters)
- Weight: 112 lbs. (w/casters)



**IT'S SMALL, IT'S SLEEK —
YOU'LL BE "SHOCKED" BY ITS PERFORMANCE!**

EEL CART - DELUXE



DELUXE EEL CART: MODEL NO. GWC-E1244D

- Completely Welded, Unitized Tubular Steel Frame
- Electrostatic Powder Coating Provides a Long-Lasting, Scuff-Resistant Finish
- Can handle up to 2,400 lbs., yet is small enough to fit into tight spots during transport!
- 2 8" Hi-Tech Silverline Swivel Casters
- 2 8" Hi-Tech Silverline Swivel Casters with Wheel Lock
- Heavy Duty Compression Fit Upright Protectors—Installed
- Heavy Duty Industrial Strength Rubber Protectant Pad for Cart Pan—Installed
- Project Clip Board Hook
- Replaceable Parts: Upright Protectors, Rubber Protectant Pad and Casters

These Carts Will "Electrify" You!

EEL CART - STANDARD

STANDARD EEL CART: MODEL NO. GWC-E1244S

All the Same Great Features Above, Without the Rubber Padding and Compression Fit Upright Protectors

EEL CART SPECS:

- Load Capacity: 2,400 lbs.
- Platform Dimensions: 44" L x 12" W
- Overall Dimensions: 44" L x 22" W x 47" H (w/casters)
- Weight: 58 lbs. (w/casters)



PUT THE HAMMER DOWN ON TOUGH JOBS!

HAMMERHEAD CART - DELUXE



DELUXE HAMMERHEAD CART: MODEL NO. GWC-HH1244D

- Completely Welded, Unitized Tubular Steel Frame for Additional Strength and Durability
- Electrostatic Powder Coating Provides a Long-Lasting, Scuff-Resistant Finish
- 2 8" Hi-Tech Silverline Swivel Casters
- 2 8" Hi-Tech Silverline Swivel Casters w/Wheel Locks
- Heavy Duty Compression Fit Upright Protectors - Installed
- Heavy Duty Industrial Strength Rubber Protectant Pad for Cart Pan - Installed
- Project Clipboard Hook
- Replaceable Parts: Upright Protectors, Rubber Protectant Pad and Casters

HAMMERHEAD CART - STANDARD

STANDARD HAMMERHEAD CART: MODEL NO. GWC-HH1244S

All the Same Great Features Above, Without the Rubber Padding and Compression Fit Upright Protectors

HAMMERHEAD SPECS:

- Load Capacity: 2,400 lbs.
- Platform Dimensions: 44" L x 12" W
- Overall Dimensions: 50" L x 22.5" W x 47" H
- Shipping Weight: 69 lbs. (w/o casters)



YELLOW BOXFISH TOOL BOX

HEAVY DUTY STEEL TOOL BOX

YELLOW BOXFISH: MODEL NO. GWBTB

- Constructed of 14 Ga. Steel for Strength and Durability
- Weep Holes Allow for Water Drainage
- Locates Easily on All Gulf Wave Fabrication Table Ends and Modular Extensions for Quick Installation
- Safety Latch Pin Holds the Tool Box in Position

SPECS:

Dimensions: Large Capacity - 28" L x 7" W x 6-1/2" H
Weight: 20 lbs.



THE REEF

5 FT. A-FRAME

THE REEF: MODEL NO. GW-5AF

- Capacity: 12,000 lbs. per side
- Middle Support Bar Connects A-Frame End Pieces
- Ships Flat (Some Assembly Required)

SPECS:

Dimensions: 60" X 60" X 58"
Weight: 141 lbs.



SEA BASS DOLLY

HEAVY DUTY STEEL SLAB DOLLY

SEA BASS DOLLY: MODEL NO. GWSB-10

- Heavy Duty Steel Construction
- 10" Duraflex Cushion Rubber Wheels
- Twin Handles for Grasping or Strapping
- Durable Powder Coated Finish
- Ships Fully Assembled

SPECS:

Dimensions: 18" L x 10-1/2" W x 10" H (4" W Interior Channel)
Weight: 25 lbs.
1,000 lb. Weight Capacity



EXTREME HEAVY-DUTY MATERIAL HANDLING CARTS

THE MANATEE



THE MANATEE

If you've got a big job, this versatile cart is up to the task!

With four removable upright posts, this cart has multiple functions, including an industrial strength transport wagon, a heavy-duty dolly, a material handling cart or, when not in use, lock the brakes and use it for storage.

MANATEE: MODEL NO. GWC-M66

- Load Capacity: 2,400 lbs.
- Comes with four 8" Total Lock Swivel Plate Casters w/Hi-Tech Non-Marking Wheels
- Heavy Duty Nut and Bolt Caster Installation makes for easy caster replacement
- Removable Upright Bars (Ships broken down)
- Weight: 112 lbs.
- Dimensions: 73" L x 29" W x 58" H (w/casters)



THE MANATEE JR

MANATEE JR: MODEL NO. GWC-M44

- Load Capacity: 2,400 lbs.
- Comes with four 8" Total Lock Swivel Plate Casters w/Hi-Tech Non-Marking Wheels
- Heavy Duty Nut and Bolt Caster Installation makes for easy caster replacement
- Removable Upright Bars (Ships broken down)
- Weight: 84 lbs.
- Dimensions: 49" L x 29" W x 50.5" H (w/casters)





IF YOU DON'T SEE WHAT YOU NEED,
CONTACT US!

GULF WAVE HAS THE CAPACITY TO
MANUFACTURE PRODUCTS TO SUIT THE
NEEDS OF ITS CUSTOMERS

For More Information Contact:

Gulf Wave Custom Design

Phone: (317) 610-6078

Email: sales@gulfwavecustomdesign.com

www.gulfwavecustomdesign.com

