

UV PURE®

Powerful UV disinfection for difficult water

Smart technology.
High performance.
Easy maintenance.

Up to
100 gpm
per unit, multiplex
systems available

35%
minimum UV
transmittance

uvpure.com



Count on Hallett for any application



Potable



Wastewater



Reuse



Rainwater

Safe water, always.™

Table of Contents

UV Pure Advance UV disinfection for challenging water – Crossfire Technology™	3
Meet the New Hallett – Questions & Answers	5
Product Line Feature comparison	7
Hallett Models & Specifications	8
Technical Data Sheets	
Hallett 1000 Series	9
Hallett 750 Series	12
Hallett 500 Series	14
Selected Current Installations	16
Selected Case studies	17
Contact Us	18

UV Pure, UV Pure logo, Crossfire Technology, Crossfire Technology logo, and Hallett logo are registered trademarks in Canada and USA of UV Pure Technologies Inc., a subsidiary of Clearford Water Systems Inc. Other trademarks of UV Pure include: Hallett, Upstream, Cactus, 'Pure Safe Water, Always.' and 'Safe Water, Always.'



Advanced UV disinfection for challenging water

UV Pure Technologies is a manufacturer of advanced ultraviolet water disinfection systems for commercial, industrial, municipal, residential, and decentralized applications, with worldwide installations in:

- COMMERCIAL
- SYSTEM INTEGRATORS
- AGRI-FOOD
- AGRICULTURE
- MUNICIPAL
- PARKS & RECREATION
- HEALTHCARE
- RESIDENTIAL
- TRANSPORTATION



Potable



Wastewater



Reuse



Rainwater



The company's range of Hallett™ products are proven for use in potable, wastewater, reuse, and rainwater disinfection systems for flows of up to 3,800 cubic metres per day (1 million gallons per day).

Hallett systems are certified to NSF/ANSI 55 Class A, NSF/ANSI/CAN 61 & 372, with performance validation to EPA & NWRRI protocols for a wide range of operating conditions including low UV transmittance water. Non-certified Hallett systems are also available to achieve the same performance for applications that do not require formal certification.

UV Pure™ systems feature patented Crossfire Technology® with an innovative dual-lamp elliptical reflector design, self-cleaning quartz sleeve, and smart sensors for on-board diagnostics and remote monitoring capabilities. Crossfire Technology was selected for water disinfection on the new Boeing 787 Dreamliner, and is trusted by water industry leaders including SUEZ (formerly GE Water), Evoqua (formerly Siemens Water), the Los Angeles Department of Water and Power, Veolia, and CH2M.

UV Pure has earned an Artemis Top 50 Clean Tech Company award, Going Green Global Top 200 award, two Frost & Sullivan Best Practices Awards, and a Canadian Drinking Water Association award for innovation.

Crossfire Technology[®] targets pathogens from every angle - 360 degrees

Powered by

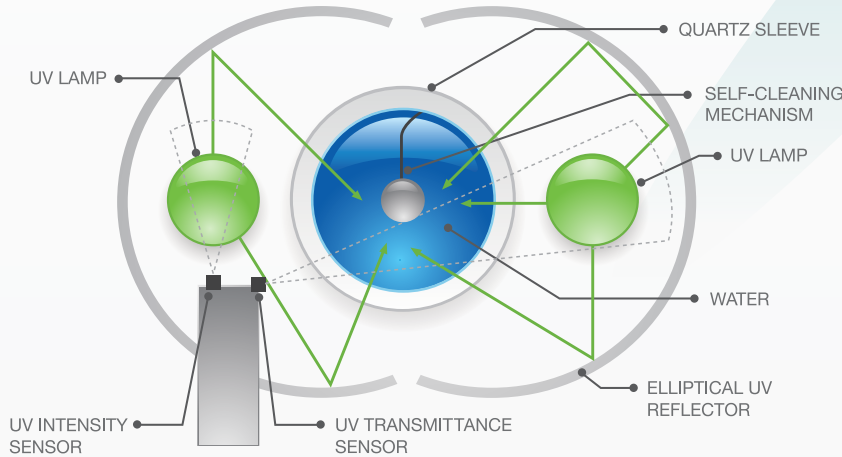

Conventional System

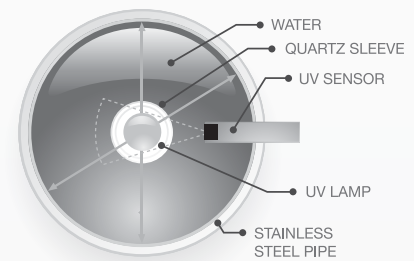

- ✓ Self-cleaning system prevents quartz fouling
- ✓ Reliable high performance in low UVT conditions
- ✓ Safe, easy lamp changes
- ✓ Smart sensors for real-time monitoring

UV Pure's patented Crossfire Technology incorporates elliptical reflectors that redirect light energy from 360 degrees to overcome shadowing and deliver a sterilizing UV dose to harmful pathogens.

Dual smart UV sensors in every Hallett system continually monitor lamp output and water quality to ensure the highest level of disinfection is consistently achieved. The smart sensors practically eliminate nuisance alarms and make troubleshooting simple when the system is out of compliance.



Effective disinfection for up to 10x more difficult water with UV transmittance from 35-95%, hardness up to 855 mg/L, and iron up to 3 mg/L



Safe water, always.™

Call Us: 1-888-407-9997

www.uvpure.com

info@uvpure.com

Meet the New Hallett™ Questions & Answers

UV
PURE®

Call Us: 1-888-407-9997

Questions

Answers

What's new about UV Pure's Hallett products?

UV Pure® has redesigned its next generation Hallett™ product series with all new features for even better reliability and operability. All of UV Pure's products are powered by Crossfire Technology® for industry-leading disinfection performance, even for challenging water quality conditions.

There are **four new Hallett product lines** to meet a wide range of UV water disinfection needs:



- Hallett P for potable and drinking water applications
- Hallett R for reuse (gray water and rainwater) applications
- Hallett W for wastewater applications

What **sizes** are available for the new Hallett?

There are **three model sizes** for the new Hallett product lines that handle flows from 10-100 US gpm and UV transmittance (UVT) as low as 35%. The sizes are based on the nominal UV lamp length (in millimeters) for each unit:

- Hallett 500
- Hallett 750
- Hallett 1000 – all new

What is the **new Hallett 1000**?



The new Hallett 1000 is our largest model yet with a 2-inch connection for flows up to 100 US gpm. It is equipped with amalgam lamps that can be cycled 6-12 times per day, plus quadruple smart UV sensors. Use it for any application including potable water, wastewater, reuse water or rainwater.

What product certifications and validations are available for the new Hallett?

The new Hallett lineup includes models with ANSI/NSF certifications and third-party performance validation in accordance with the US EPA UV Disinfection Guidance Manual (UVDGM) and NWRI UV Disinfection Guidelines for Drinking Water and Water Reuse.

- UL 979 and CSA C22.2 No.68-09 – all Hallett models
- NSF/ANSI 55 Class A – Hallett PN Series
- NSF/ANSI/CAN 61 and NSF/ANSI 372 – all Hallett models
- EPA UVDGM validation – Hallett 1000
- NWRI validation – Hallett 1000

What new **features** does the next generation Hallett have?



All new Hallett models are equipped with:

- Color touchscreen interface
- Improved dual UV sensor array design with quad-sensor models available
- Better temperature management with built-in purge valve and available lamp heaters
- Optional 4-20 mA output with MODBUS connectivity
- Remote start capability
- Two dry contacts for warning and alarm signals
- Better message history that stores the last 99 messages with timestamp
- Optional data logging through USB port
- Built-in surge protection

What has **NOT changed** in the new Hallett systems?

New Hallett systems are still powered by UV Pure patented Crossfire Technology™ including:

- Automatic self-cleaning wipers and built-in purging that prevent fouling of the quartz sleeve by mineral scaling and biofilm, making Hallett up to 10 times more effective in difficult water applications than conventional UV systems
- Dual air-mounted lamps with forced air cooling that provide better UV chamber temperature control, helping to eliminate false lamp alarms
- Elliptical reflector design that captures and redirects UV energy from 360 degrees to minimize UV shadowing and prevent live transfer of bacteria and microorganisms
- Dual UV sensor array that provides real-time monitoring of UV lamp intensity, UV dose and net UVT while enabling superior on-board diagnostics for troubleshooting

All Hallett systems are still non-contact, meaning the operator is not exposed to contaminated water when performing routine maintenance like quartz inspections and lamp changes. In fact, the new Hallett design makes maintenance even easier.

With its small footprint and simple plug-and-play design, Hallett is quick to install and easy to start up, even in tight spaces.

Automatic Mechanical Self-cleaning	360° Coverage	Non-Contact Maintenance	Smart Sensors	Quick & Easy Installation

What are the warranty terms for new Hallett systems?

We continue to offer one of the industry's leading warranty packages for UV Pure systems and parts:

- 12 months on sensors, temperature probes, and valves
- 12 months on LPHO lamps
- 16 months on amalgam lamps
- 36 months on electrical components, quartz sleeve, and reflectors
- 60 months for structural, hardware, and mechanical components

Are engineering drawings available for the new Hallett systems?

Yes, engineering drawings are available for single and multi-unit Hallett systems. For help with sizing or drawings, please contact your UV Pure sales professional or send a request to info@uvpure.com.

Product Line Feature comparison

Effective August 1, 2019



Feature	Hallett 1 st Generation	Hallett Upstream 2 nd Generation	Hallett 3 rd Generation	Hallett 3 rd Generation
	H30, H13	H15xs, NC series	H500, H750 series	H1000 series
Crossfire Technology	Built in	Built in	Built in	Built in
>> Elliptical Reflectors, >> 360° Disinfection	Built in	Built in	Built in	Built in
>> Dual Lamps, >> Multiple Sensors	Built in	Built in	Built in	Built in
>> Self cleaning mechanism	Built in	Built in	Built in	Built in
User Interface	Single button	Four mechanical buttons	Touch screen Color	Touch screen Color
Operational alarms	Dual visual - audible	Dual visual - audible	Dual visual - audible	Dual visual - audible
Display - Liquid Crystal (LCD)	Optional	Built in	Touch screen Color	Touch screen Color
Communications	4-20 mA output	Not available	4-20 mA output Modbus	4-20 mA output Modbus
UV Intensity Warning Dry Contact	NA	NA	Built in	Built in
Remote Start/Stop	NA	NA	Built in	Built in
Built-in Surge Protection	Optional	Optional	Built in	Built in
Message History	NA	Last 50 messages	Last 99 messages	Last 99 messages
Data logging - local	NA	NA	Optional	Optional
Flow range (@ 40 mJ/cm ² , 95% UVT)	up to 51 USgpm 193 L/min	up to 51 USgpm 193 L/min	up to 51 USgpm 193 L/min	up to 100 USgpm 378 L/min
Minimum UVT required	45%	50%	50%	35%
Lamp Type	LPHO	LPHO	LPHO	Amalgam
Lamp Expected Life	9000 hours	9000 hours	9000 hours	9000 hours
Lamp Heaters	NA	NA	Available	Available
Time Needed for Lamp Change	5 minutes	< 5 minutes	< 2 minutes	< 2 minutes
Sensor Design	Analog technology	Digital technology	Digital technology NIST compliant	Digital technology NIST compliant
Dual Sensors	One per unit	One per unit	One per unit	One per lamp 2 per unit
Temperature Control	Convection cooling Optional purge valve	Forced air cooling Built-in purge valve	Improved forced air cooling Built-in purge valve	Improved forced air cooling Built-in purge valve
Performance Validation	Factory Tested	Factory Tested	Third party Validation (1)	US EPA UVDGM Validated
Drinking Water Performance Certification	NSF/ANSI 55 Class A	NSF/ANSI 55 Class A	NSF/ANSI 55 Class A	NWRI / Validation
Drinking Water System Components – Health Effects / Lead Free Compliance	NSF/ANSI/CAN 61 certified	NSF/ANSI/CAN 61 certified	NSF/ANSI/CAN 61 & 372 certified	NSF/ANSI/CAN 61 & 372 certified
Drinking Water and Water Reuse Performance Validation	Factory Tested	Factory Tested	Factory Tested	NWRI Validation

(1) Pending

(2) NA - Not available



v.20210218

Safe water, always.™

1-888-407-9997

info@uvpure.com
www.uvpure.com

Hallett Models & Certifications

Product Line	Hallett P 	Hallett W 	Hallett R 
Applications	Potable	Wastewater	Reuse & Rainwater
Hallett Models	1000, 750, 500, 750PN, 500PN	1000, 750, 500	1000, 750, 500
Certifications & Validations	All Models - NSF/ANSI/CAN 61 & 372		
	NSF/ANSI 55 Class A (PN models only)	EPA wastewater validated (1000 model only)	NWRI reuse validated (1000 model only)
	EPA UVDGM validated – 1000 model only		

Download UV Pure Technical Data Sheets at uvpure.com/downloads/

Technical Data Sheet

Hallett™ 1000P

www.uvpure.com

Potable Water Applications



Model

Hallett 1000P

Validation protocol

US EPA UVDGM
IECEE CB + CE Mark

Operating Range

Flow (single unit)*	Up to 100 US gpm (378 lpm)
UV dose	16 - 200 mJ/cm ²
UV Transmittance [UVT] (water)	50 - 95% UVT
Hardness (water)	Maximum 855 mg/L (50 gpg)
Iron (water)	Maximum 3 mg/L (3 ppm)
Temperature (air)	34 - 104°F (1 - 40°C)
Temperature (water)	34 - 95°F (1 - 35°C)
Water pressure	5 - 100 psig (34 - 690 kPa)
Relative humidity (air)	Maximum 70%

Features

Quartz sleeve cleaning
Wiper position switch
Purge valve
Cooling
Flow restrictor
Shut-off valve

Built-in - automatic mechanical wiper
Built-in
Built-in
Built-in - forced air
Optional - external
Optional - automatic solenoid

Electrical/Instrumentation

Voltage	120/230 V AC, 50/60 Hz
Power consumption (nominal)	403 W
Certifications	UL 979
UV lamps	Dual amalgam - air mounted
Lamp life (typical)	12,000 hours
Lamp cycles (recommended)	Maximum 6 to 12 cycling per 24 hours
Sensors	Quad UV - calibrated to NIST standards
Dry contacts	Built-in - 2 provided (warning and alarm)
Interface	Colour LCD resistive touchscreen display
Alarming	Indicator light and audible alarms
Remote start/stop	Built-in
Onboard diagnostics	Built-in
4-20mA Output & Modbus	Optional

Physical

Dimensions (H x W x D)	55.8 x 11.5 x 8.6 in (1418 x 291 x 218 mm)
Weight (dry)	52 lb (23.5 kg)
Weight (wet)	58.3 lb (26.4 kg)
Wetted parts	Meets NSF/ANSI/CAN 61 & NSF/ANSI 372 for water up to 73°F (23°C)
Body materials	Anodized aluminum and 316 Stainless Steel
Body configuration	Double door with side hinges
Inlet/outlet ports	2" MNPT Stainless Steel, optional - Stainless Steel hose
Ingress Protection rating	IP 51, optional - IP 66 for NEMA cabinet systems
Multiple units	Multiplex manifold and cabinets available
Warranty	5-year limited warranty for structural, hardware and mechanical components; 3-year limited warranty on electrical components and quartz sleeves; 16-month limited warranty on bulbs; and 1-year limited warranty on sensor probes

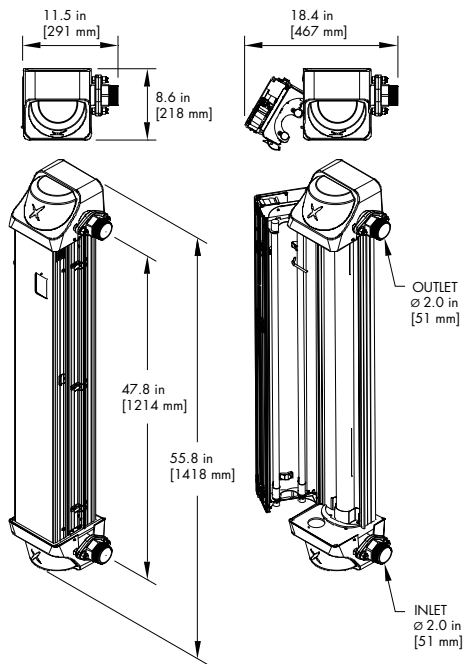

Contact a UV Pure representative to confirm product operating parameters for specific applications.

info@uvpure.com

*Maximum flow for single unit is 100 gpm (378 L/min). Multiplex manifold and cabinet systems available for flows up to 1 MGD (3,800 m³/day).

Technical Data Sheet

Hallett™ 1000R

www.uvpure.com

Reuse & Rainwater Applications



Model Validation protocol

Hallett 1000R
US EPA UVDGM/NWRI
IECEE CB + CE Mark

Operating Range

Flow (single unit)*	Up to 75 US gpm (284 Lpm)
UV dose	50 - 150 mJ/cm ²
UV Transmittance [UVT] (water)	55 - 90% UVT for North America 35 - 90% UVT for Australia
Hardness (water)	Maximum 855 mg/L (50 gpg)
Iron (water)	Maximum 3 mg/L (3 ppm)
Temperature (air)	34 - 104°F (1 - 40°C)
Temperature (water)	34 - 95°F (1 - 35°C)
Water pressure	5 - 100 psig (34 - 690 kPa)
Relative humidity (air)	Maximum 70%

Features

Quartz sleeve cleaning	Built-in - automatic mechanical wiper
Wiper position switch	Built-in
Purge valve	Built-in
Cooling	Built-in - forced air
Flow restrictor	Optional - external
Shut-off valve	Optional - automatic solenoid

Electrical/Instrumentation

Voltage	120/230 V AC, 50/60 Hz
Power consumption (nominal)	403 W
Certifications	UL 979
UV lamps	Dual amalgam - air mounted
Lamp life (typical)	12,000 hours
Lamp cycles (recommended)	Maximum 6 to 12 cycling per 24 hours
Sensors	Quad UV - calibrated to NIST standards
Dry contacts	Built-in - 2 provided (warning and alarm)
Interface	Colour LCD resistive touchscreen display
Alarming	Indicator light and audible alarms
Remote start/stop	Built-in
Onboard diagnostics	Built-in
4-20mA Output & Modbus	Optional

Physical

Dimensions (H x W x D)	55.8 x 11.5 x 8.6 in (1418 x 291 x 218 mm)
Weight (dry)	52 lb (23.5 kg)
Weight (wet)	58.3 lb (26.4 kg)
Wetted parts	Meets NSF/ANSI/CAN 61 & NSF/ANSI 372 for water up to 73°F (23°C)
Body materials	Anodized aluminum and 316 Stainless Steel
Body configuration	Double door with side hinges
Inlet/outlet ports	2" MNPT Stainless Steel, optional - Stainless Steel hose
Ingress Protection rating	IP 51, optional - IP 66 for NEMA cabinet systems
Multiple units	Multiplex manifold and cabinets available
Warranty	5-year limited warranty for structural, hardware and mechanical components; 3-year limited warranty on electrical components and quartz sleeves; 16-month limited warranty on bulbs; and 1-year limited warranty on sensor probes

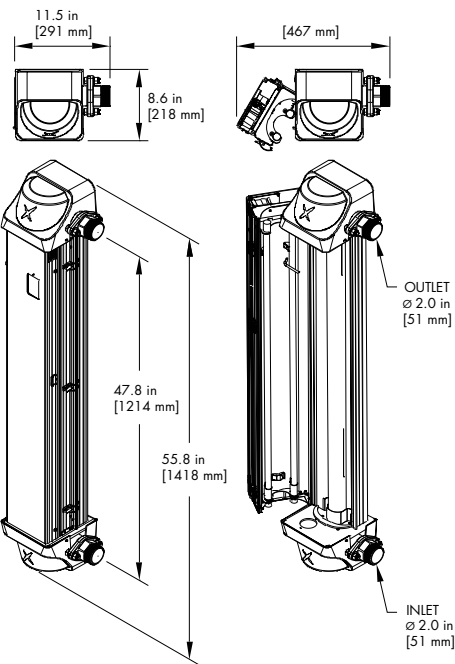

Contact a UV Pure representative to confirm product operating parameters for specific applications.

info@uvpure.com

*Maximum flow for single unit is 100 gpm (378 L/min). Multiplex manifold and cabinet systems available for flows up to 1 MGD (3,800 m³/day).

Technical Data Sheet

Hallett™ 1000W

www.uvpure.com

Wastewater Applications



Model

Hallett 1000W

Validation protocol

US EPA UVDGM
IECEE CB + CE Mark

Operating Range

Flow (single unit)*	Up to 75 US gpm (284 Lpm)
UV dose	16 - 60 mJ/cm ²
UV Transmittance [UVT] (water)	35 - 80% UVT
Hardness (water)	Maximum 855 mg/L (50 gpg)
Iron (water)	Maximum 3 mg/L (3 ppm)
Temperature (air)	34 - 104°F (1 - 40°C)
Temperature (water)	34 - 95°F (1 - 35°C)
Water pressure	5 - 100 psig (34 - 690 kPa)
Relative humidity (air)	Maximum 70%

Features

Quartz sleeve cleaning	Built-in - automatic mechanical wiper
Wiper position switch	Built-in
Purge valve	Built-in
Cooling	Built-in - forced air
Flow restrictor	Optional - external
Shut-off valve	Optional - automatic solenoid

Electrical/Instrumentation

Voltage	120/230 V AC, 50/60 Hz
Power consumption (nominal)	403 W
Certifications	UL 979
UV lamps	Dual amalgam - air mounted
Lamp life (typical)	12,000 hours
Lamp cycles (recommended)	Maximum 6 to 12 cycling per 24 hours
Sensors	Quad UV - calibrated to NIST standards
Dry contacts	Built-in - 2 provided (warning and alarm)
Interface	Colour LCD resistive touchscreen display
Alarming	Indicator light and audible alarms
Remote start/stop	Built-in
Onboard diagnostics	Built-in
4-20mA Output & Modbus	Optional

Physical

Dimensions (H x W x D)	55.8 x 11.5 x 8.6 in (1418 x 291 x 218 mm)
Weight (dry)	52 lb (23.5 kg)
Weight (wet)	58.3 lb (26.4 kg)
Wetted parts	Meets NSF/ANSI/CAN 61 & NSF/ANSI 372 for water up to 73°F (23°C)
Body materials	Anodized aluminum and 316 Stainless Steel
Body configuration	Double door with side hinges
Inlet/outlet ports	2" MNPT Stainless Steel, optional - Stainless Steel hose
Ingress Protection rating	IP 51, optional - IP 66 for NEMA cabinet systems
Multiple units	Multiplex manifold and cabinets available
Warranty	5-year limited warranty for structural, hardware and mechanical components; 3-year limited warranty on electrical components and quartz sleeves; 16-month limited warranty on bulbs; and 1-year limited warranty on sensor probes

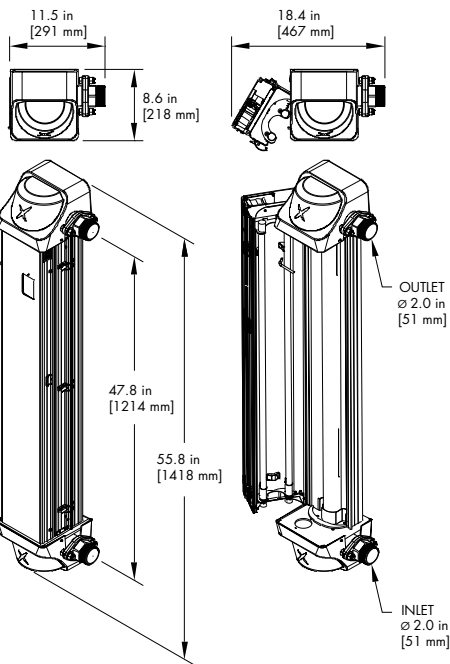

Contact a UV Pure representative to confirm product operating parameters for specific applications.

info@uvpure.com

*Maximum flow for single unit is 100 gpm (378 L/min). Multiplex manifold and cabinet systems available for flows up to 1 MGD (3,800 m³/day).

Technical Data Sheet

Hallett™ 750PN

www.uvpure.com

Potable Water Applications



Model Validation protocol

Hallett 750PN
NSF/ANSI 55 CLASS A
NSF by NSF International

Operating Range

Flow (single unit)	Up to 27.4 US gpm (104 lpm)
UV dose	Min. 40 mJ/cm ²
UV Transmittance [UVT] (water)	Minimum 75% UVT
Hardness (water)	Maximum 855 mg/L (50 gpg)
Iron (water)	Maximum 3 mg/L (3 ppm)
Temperature (air and water)	34 - 104°F (1 - 40°C)
Water pressure	5 - 100 psig (34 - 690 kPa)
Relative humidity (air)	Maximum 70%

Features

Quartz sleeve cleaning	Built-in - automatic mechanical wiper
Wiper position switch	Built-in
Purge valve	Built-in
Cooling	Built-in - forced air
Flow restrictor	Standard - internal
Shut-off valve	Optional - automatic solenoid

Electrical/Instrumentation

Voltage	120 V AC, 50/60 Hz
Power consumption (nominal)	222 W
Certifications	UL 979
UV lamps	Dual LPHO - air mounted
Lamp life (typical)	9,000 hours
Lamp cycles (recommended)	Maximum 2 per 24 hours
Sensors	Dual UV - calibrated to NIST standards
Dry contacts	Built-in - 2 provided (warning and alarm)
Interface	Colour LCD resistive touchscreen display
Alarming	Indicator light and audible alarms
Remote start/stop	Built-in
Onboard diagnostics	Built-in
4-20mA Output & Modbus	Optional

Physical

Dimensions (H x W x D)	40.4 x 9.6 x 8.6 in (1026 x 244 x 218 mm)
Weight (dry)	34 lb (15.5 kg)
Weight (wet)	38 lb (17.2 kg)
Wetted parts	Meets NSF/ANSI/CAN 61 & NSF/ANSI 372 for water up to 73°F (23°C)
Body materials	Anodized aluminum and 316 Stainless Steel
Body configuration	Double door with side hinges
Inlet/outlet ports	1" MNPT Stainless Steel, optional - Stainless Steel hose
Ingress Protection rating	IP 51, optional - IP 66 for NEMA cabinet systems
Multiple units	Multiplex manifold and cabinets available
Warranty	5-year limited warranty for structural, hardware and mechanical components; 3-year limited warranty on electrical components and quartz sleeves; 12-month limited warranty on bulbs; and 1-year limited warranty on sensor probes

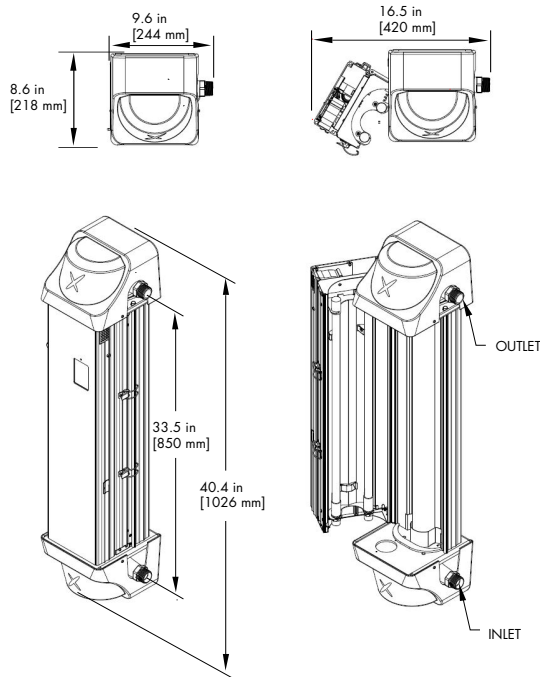

Contact a UV Pure representative to confirm product operating parameters for specific applications.

info@uvpure.com

The Hallett 750PN is installed indoors on a wall in a dry location. The unit should be plumbed in downstream of any pretreatment devices but upstream of distribution plumbing. The Hallett 750PN plugs into a 120Vac ground-fault circuit-interrupter (GFCI). The Hallett 750PN incorporates both audible and visual alarms to indicate system status and an optional normally closed solenoid valve is available to shut off the water supply in the event of a system fault.

The automatic quartz cleaning feature is engineered to eliminate the periodic maintenance required by conventional UV systems. The UV lamps p/n C300064, Lamp Pair p/n C300065, require replacement after 12 months of operation.



System Tested and Certified by NSF International against NSF/ANSI Standard 55 for Disinfection Performance, Class A.

This Class A system conforms to NSF/ANSI 55 for the disinfection of microbiologically contaminated water that meets all other public health standards. This system is not intended to convert wastewater or raw sewage to drinking water. The system is intended to be installed on visually clear water.

NSF/ANSI 55 defines wastewater to include human and/or animal body waste, toilet paper, and any other material intended to be deposited in a receptacle designed to receive urine and/or feces (blackwaste); and other waste materials deposited in plumbing fixtures (greywaste).

If this system is used for the treatment of untreated surface waters or ground water under the direct influence of surface water, a device found to be in conformance for cyst reduction under the appropriate NSF/ANSI Standard shall be installed upstream of the system.

Manufactured by: UV Pure Technologies Inc.

455 Milner Avenue Toronto,
Ontario, M1B 2K4
416-208-9884
888-407-9997
info@uvpure.com

All replacement parts may be purchased through UV Pure.

Technical Data Sheet

Hallett™ 500PN

www.uvpure.com

Potable Water Applications



Model Validation protocol

Hallett 500PN
NSF/ANSI 55 CLASS A
NSF by NSF International

Operating Range

Flow (single unit)	Up to 16.5 US gpm (62.5 lpm)
UV dose	Min. 40 mJ/cm ²
UV Transmittance [UVT] (water)	Minimum 75% UVT
Hardness (water)	Maximum 855 mg/L (50 gpg)
Iron (water)	Maximum 3 mg/L (3 ppm)
Temperature (air and water)	34 - 104°F (1 - 40°C)
Water pressure	5 - 100 psig (34 - 690 kPa)
Relative humidity (air)	Maximum 70%

Features

Quartz sleeve cleaning	Built-in - automatic mechanical wiper
Wiper position switch	Built-in
Purge valve	Built-in
Cooling	Built-in - forced air
Flow restrictor	Standard - internal
Shut-off valve	Optional - automatic solenoid

Electrical/Instrumentation

Voltage	120 V AC, 50/60 Hz
Power consumption (nominal)	196 W
Certifications	UL 979
UV lamps	Dual LPHO - air mounted
Lamp life (typical)	9,000 hours
Lamp cycles (recommended)	Maximum 2 per 24 hours
Sensors	Dual UV - calibrated to NIST standards
Dry contacts	Built-in - 2 provided (warning and alarm)
Interface	Colour LCD resistive touchscreen display
Alarming	Indicator light and audible alarms
Remote start/stop	Built-in
Onboard diagnostics	Built-in
4-20mA Output & Modbus	Optional

Physical

Dimensions (H x W x D)	36.5 x 9.6 x 8.6 in (926 x 244 x 218 mm)
Weight (dry)	32 lb (14.6 kg)
Weight (wet)	36 lb (16.3 kg)
Wetted parts	Meets NSF/ANSI/CAN 61 & NSF/ANSI 372 for water up to 73°F (23°C)
Body materials	Anodized aluminum and 316 Stainless Steel
Body configuration	Double door with side hinges
Inlet/outlet ports	1" MNPT Stainless Steel, optional - Stainless Steel hose
Ingress Protection rating	IP 51, optional - IP 66 for NEMA cabinet systems
Multiple units	Multiplex manifold and cabinets available
Warranty	5-year limited warranty for structural, hardware and mechanical components; 3-year limited warranty on electrical components and quartz sleeves; 12-month limited warranty on bulbs; and 1-year limited warranty on sensor probes

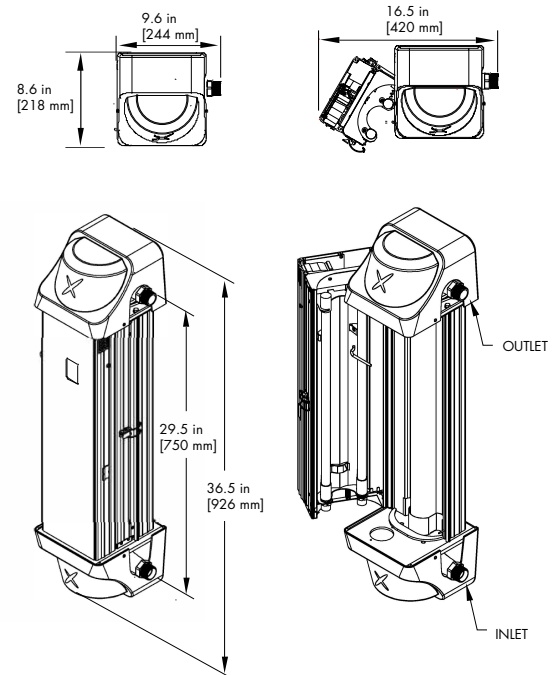

Contact a UV Pure representative to confirm product operating parameters for specific applications.

info@uvpure.com

The Hallett 500PN is installed indoors on a wall in a dry location. The unit should be plumbed in downstream of any pretreatment devices but upstream of distribution plumbing. The Hallett 500PN plugs into a 120Vac ground-fault circuit-interrupter (GFCI). The Hallett 500PN incorporates both audible and visual alarms to indicate system status and an optional normally closed solenoid valve is available to shut off the water supply in the event of a system fault.

The automatic quartz cleaning feature is engineered to eliminate the periodic maintenance required by conventional UV systems. The UV lamps p/n E300209, Lamp Pair p/n E300210, require replacement after 12 months of operation.



System Tested and Certified by NSF International against NSF/ANSI Standard 55 for Disinfection Performance, Class A.

This Class A system conforms to NSF/ANSI 55 for the disinfection of microbiologically contaminated water that meets all other public health standards. This system is not intended to convert wastewater or raw sewage to drinking water. The system is intended to be installed on visually clear water.

NSF/ANSI 55 defines wastewater to include human and/or animal body waste, toilet paper, and any other material intended to be deposited in a receptacle designed to receive urine and/or feces (blackwaste); and other waste materials deposited in plumbing fixtures (greywaste).

If this system is used for the treatment of untreated surface waters or ground water under the direct influence of surface water, a device found to be in conformance for cyst reduction under the appropriate NSF/ANSI Standard shall be installed upstream of the system.

Manufactured by: UV Pure Technologies Inc.

455 Milner Avenue Toronto,
Ontario, M1B 2K4
416-208-9884
888-407-9997
info@uvpure.com

All replacement parts may be purchased through UV Pure.

Current Installations

Generation 3

Parks Canada / Arcadis – Canada wide (2019) – Potable Water

UV Pure® is pleased to announce our partnership with Parks Canada on their Trent Severn UV upgrade project through UV Pure Channel partner in Ontario. Parks Canada is replacing conventional UV systems on more than 30 park sites with UV Pure third Generation of UV's. Parks Canada becomes the first government agency to incorporate our latest UV technology in their parks and campgrounds.

Generation 1 & 2

Memorial Sloan Kettering Cancer Center – New York City, NY, USA (2019) – Potable Water

UV Pure® is proud to announce our recent installations at Memorial Sloan Kettering Cancer Center, NY. MSKCC is the largest and oldest private cancer center in the world. This shipment is part of comprehensive disinfection package offered by UV Pure channel partner in the New York region. UV Pure supplied 2 large plug and play multiplex UV disinfections modules to the facility and allowing the Cancer center to meet it's extremely high water quality objectives.



Case Studies

Potable Water

- Heriot Bay – Quadra Island, BC – Canada (2015)
The automatic self-cleaning mechanism in the UV Pure® Hallett™ system enabled Heriot Bay Inn to eliminate the alarms, iron fouling and frequent cleanings that were often experienced with a conventional light-in-a-pipe UV unit.
- Tallahassee VA Outpatient Clinic – Tallahassee, Florida – USA (2016)
US Veterans Administration clinic adds UV Pure® systems to protect patients from Legionella and chlorine-resistant pathogens.
- Progresar ESP – Valle del Rio Teusaca, Cundinamarca – Colombia (2015)
Colombian community responds to stronger water regulations with UV Pure® systems.
- Parkbridge Sama Community – Havelock, ON – Canada (2004) – Potable water
No fouling to Hallett™ systems after more than a decade of hard water treatment at a recreational community.

Rainwater

- GO Transit Bus Service and Storage Facility - Hamilton, ON – Canada (2016)
UV Pure® systems provide chemical-free disinfection of harvested rainwater for bus wash station.
- Algoma Orchards – Newcastle, ON – Canada (2017)
Algoma Orchards recycles process water and gains efficiency.

Wastewater

- Cataumet Wastewater treatment plant – Cataumet, MA – USA (2017)
UV Pure® Hallett™ systems team with decentralized MBBR to protect sensitive marine environment.

Read more about UV Pure's case studies at uvpure.com/case-studies/

Contact Us

Manufacturing Facility: UV Pure Technologies Inc.

1-455 Milner Ave, Toronto, ON, Canada M1B 2K4

Tel: +1 (416) 208 9884 | **Website:** www.uvpure.com
Toll Free: +1 (888) 407 9997 | **Email:** info@uvpure.com

Sean Woodland

National Sales Manager – Canada

Tel: +1 (888) 407 9997

Cell: +1 (613) 876 9237

Email: swoodland@uvpure.com

Robert Cundall

Regional Sales Manager – Eastern US

Tel: +1 (888) 407 9997

Cell: +1 (315) 565 8835

Email: rcundall@uvpure.com

Lisa Vandepol

Customer Service Coordinator

Cell: +1 (416) 208 9884 ext. 229

Email: lvandepol@uvpure.com

Alex Zammit

Service Manager

Tel: +1 (416) 208 9884 ext. 222

Email: azammit@uvpure.com