

JETCORE XL & JETCORE

Heavy Commercial Rating,
meets or exceeds NALFA
Class 4 requirements for,

**IMPACT, STATIC LOAD,
& SURFACE BONDING.**



DIMENSIONAL STABILITY

JetCore's waterproof rigid JetCore core features outstanding dimensional stability. Our proprietary blend used for JetCore's core is a rigid high-density 6.0mm core that allows for dimensional stability, resistance to; heat, uv light and telegraphing. JetCore passes across the board for ASTM Testing at a Class 4 Heavy Duty Commercial rating with a wear resistance of 6000 cycles. Typical vinyl flooring tests out averaging at 2000-4000 cycles. With the Class 4 rating these floors are ultra tough.



KID & PET FRIENDLY

With an enhanced XSR™ extra scratch resistant coating, JetCore flooring is sure to last for years to come. The XSR surface and a 22mil wear layer, create a stress free flooring. No need to worry about pets or furniture scratching up your floors when it comes to our JetCore. With ultra resistance no need to worry about the little accidents.



WATERPROOF

Ideal for kitchens, bathrooms, laundry rooms, salons, and cafes any location where moisture may be a concern, this flooring can be installed. Have an accidental spill? No issues when you decide on JetCore because it is 100% waterproof.

1. UV Coating
2. 22mil Wear Layer
3. PVC Decor Film
4. Vinyl Layer
5. JetCore Core (6.0 MM)
6. iXPE Pre-Attached Pad (1.0MM)

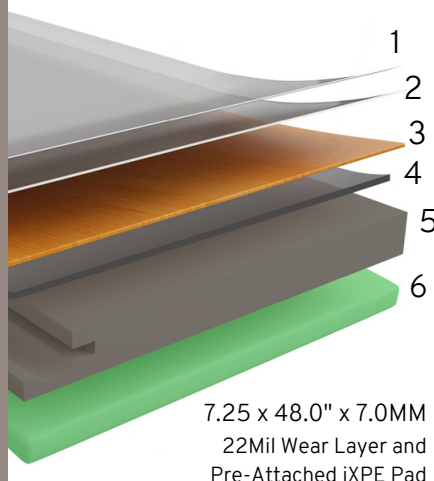

CONSTRUCTION

This flooring will stand up to any kind of heavy traffic, with an extremely high abrasion tolerance this is one of the toughest floorings on the market. No fuss maintenance and easy to clean this flooring will continue to keep its beautiful finish. Suitable for every room in the home and perfect for multi-family homes and commercial properties.