

Y'S MENETTES
INTERNATIONAL
MANUAL



FOREWORD

This Manual has been compiled to provide Y's Menettes Clubs/Y Service Clubs (Women) and personnel with helpful reference material for the smooth running of Y's Menettes affairs.

It replaces the Blue Manual of 1982-84 which was such a valuable tool for Y's Menettes for several years. We acknowledge the wonderful efforts of the then ISD Jeanie Bostrup, USA, who produced that comprehensive manual almost single-handedly.

The Y's Menettes movement has experienced many important changes in recent years and it became clear that we needed a new Manual which reflected those changes and provided up-to-date information. The Manual Revision Committee carefully examined the old Manual, retaining relevant material while revising or deleting the remainder. To this were added many sections of helpful, new information.

2000 Update. In 1997 it was approved that a Y's Menettes Club may use the alternative name Y Service Club (Women). Therefore all references in this manual to Y's Menettes Clubs apply also to Y Service Clubs (Women).

The Committee gratefully acknowledges the assistance and encouragement given by the Y's Men International Secretary General and several key Y's Menettes throughout the world, who were consulted on the various sections of the Manual.

While we all support the basic principles of our movement in accordance with the Constitution of Y's Men International, Y's Menettes Clubs may function differently in the various parts of Y'sdom. We trust that this Manual allows for those differences and provides all Clubs with suggestions, ideas, guidance and assistance.

The Committee hopes that the loose-leaf format will enable easy access and allow for the addition of any updated material.

We strongly urge each Y's Menettes Area to form a Manual Committee to compile and add a section relevant to its own Y's Menettes Clubs. This section could include such information as its history, past leadership, job descriptions for extra personnel, financial arrangements, calendar, special events, combined functions, different committees, annual awards, bulletin judging etc. It may also be necessary to translate the Manual into a more appropriate language.

The Committee trusts that each Y's Menettes Club will then possess a Manual which will be relevant, helpful and well used.

This Manual is available online at the Y's Men International website – www.ysmen.org

Personnel consulted

Y's Menettes:-

PISD Silvy Reyes de Croci - Uruguay
PID Grace MacDonald - Canada
ID Young Ok Song - Korea
IDE Michiko Maeda - Japan
AD Marguerite MacEwen - Canada
ASD Gurli Holm - Denmark
A(S)D Myrna Wolf - USA
A(S)D Theresa Banfield - Australia
IPCo-ord Barbara Hainsworth - Canada
ISCCo-ord Elexena Ames - Canada
RSCCo-ord Rosemary Rogers - Australia

Compiled in 1994 in time for the
Singapore International Convention, July 1994
by the **MANUAL REVISION COMMITTEE**,
comprising Australian Y's Menettes:-

PAM CRAMMOND PISD Bendigo
BERYL JONES PISD Bendigo
WENDY SHELDON Eaglehawk
SHIRLEY UNMACK PID Bendigo
Lynne Pedrotti (Typist) Lansell

Y's Men

ISG Ingvar Wallin - IHQ, Geneva

TABLE OF CONTENTS

Who are Y's Menettes?	1
History of Y's Menettes	2
Mission Statement	4
Y's Menettes International Leadership	5
Abbreviations	6
Chart - Y's Menettes in Y'sdom	7
Membership	8
Club Meeting Agenda	9
Program Planning	10
Devotions – Prayers	11
Y's Menettes Supplies	12
Bulletins	13
Installation of Club Office Bearers	14
New Member Induction	16
Alternative New Member Induction	18
Constitution and Guidelines	19
Incorporation	21
Disbanding a Club	21
Charter Certificate	22
Chartering a New Y's Menettes Club	23
Sister Club Program	24
Sister Club Co-ordinator Job Description	25
Sister Club Application Form	26
Calendar	27
Voting	27
Y's Menettes International Project	28
International Project Co-ordinator Job Description	29
Special Programs/Projects of Y's Men International:-	30
Alexander Scholarship Fund	30
Brotherhood Fund	30
Time of Fast	30
Endowment Fund	31
Youth Exchange Programs - YEEP, STEP	31
Conventions	32
Inductions of Y's Menettes R(S)D/A(S)D	33
Y's Menettes Regional (Service) Director Job Description	34
Y's Menettes Area (Service) Director Job Description	36
Y's Menettes International Director Job Description	38
Club Report Form	41
R(S)D Report Form	43
Y's Menettes Director Reports	45
Club Charter Application Form	46
Y's Menettes International Projects to date	Appendix 1

TABLE OF CONTENTS - ALPHABETICAL ORDER

Abbreviations	6
Agenda for Club Meetings	9
Alex Fund	30
Area (Service) Director	36, 37
Brotherhood Fund	30
Bulletins	13
Calendar	27
Chart - Y's Menettes in Y'sdom	7
Charter Certificate	22
Chartering a New Y's Menettes Club	23, 46
Constitution and Guidelines	19, 20, 21
Conventions	32
Devotions	11
Disbanding a Club	21
Endowment Fund	31
Extension	23
History of Y's Menettes	2, 3, 4
Incorporation	21
Induction - New Member	16, 17, 18
- R(S)D/A(S)D	33
Installation - Club Office Bearers	14, 15
International Director	38, 39, 40
International Project	28, Appendix 1
International Project Co-ordinator	29
Job Description - Area (Service) Director	36, 37
- International Director	38, 39, 40
- International Project Co-ordinator	29
- Regional (Service) Director	34, 35
- Sister Club Co-ordinator	25
Membership	8
Mission Statement	4
Prayers	11
Program Planning	10
Regional (Service) Director	34, 35
Reports - Club Form	41, 42
- Director	45
- R(S)D Form	43, 44
Sister Club - Application Form	26
- Co-ordinator	25
- Program	24
STEP - Short Term Youth Exchange Program	31
Supplies	12
Time of Fast	30
Voting	27
Who are Y's Menettes?	1
YEEP - Youth Educational Exchange Program	31
Y's Menettes at Large	8
Y's Menettes International Leadership	5

WHO ARE Y'S MENETTES?

Y's Menettes are the members of Y's Menettes Clubs/Y Service Clubs (Women).

Y's Menettes may be wives of Y's Men or any women who wish to enjoy the fellowship of Y's Menettes Clubs and assist in the projects of Y's Men, the YMCA (Young Men's Christian Association) and the community.

Y'S MENETTES CLUBS / Y SERVICE CLUBS (WOMEN)-

- Are the partner organisation in Y's Men International, and share a common loyalty to the YMCA.
- Offer their member Y's Menettes opportunities for fellowship, personal development and service.
- Have as their purpose - to plan and carry out programs and projects of their own in support of Y's Men Clubs, the YMCA and their communities at Local, District, Regional, Area and International levels.
- Adopt and finance the Y's Menettes International Project which assists chosen YMCA programs in needy parts of the world.

WHERE ARE Y'S MENETTES CLUBS FOUND?

Being an International organisation, Y's Menettes Clubs are found in many parts of the world, including Africa, Asia, Australia, Canada, India, Scandinavia, South America and USA.

Many Clubs are linked through the Sister Club program.

WHEN DO Y'S MENETTES CLUBS MEET?

Meetings are usually held monthly, in members' homes, church centres or YMCAs. They generally consist of a business segment and an interesting and varied program.

WHAT DOES IT COST?

Club fees determined by each Club.

Dues in some Regions and Areas.

Minimum International contributions - refer to "Membership" (See Page 8)

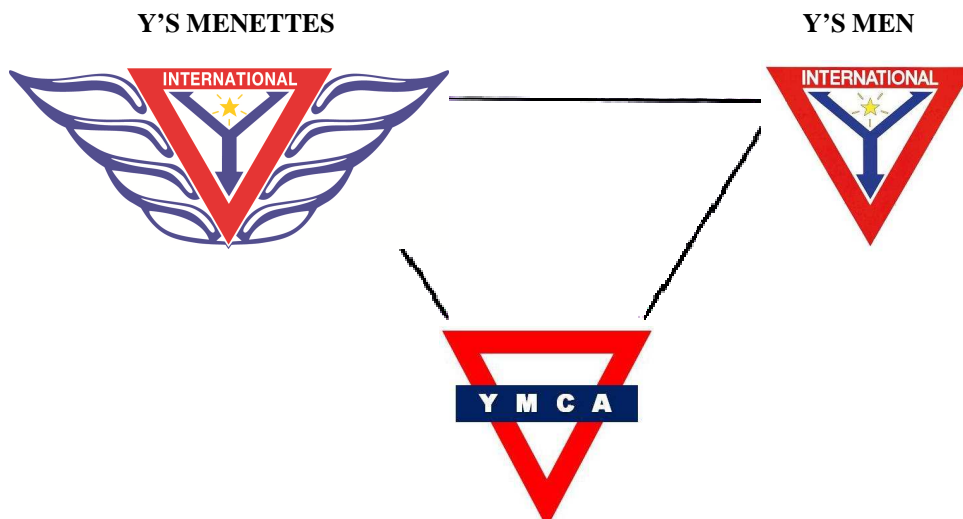

THE MOTTO OF Y'S MEN INTERNATIONAL

"To acknowledge the duty that accompanies every right."

HISTORY OF Y'S MENETTES

The first Y's Men's Club was formed in Toledo, Ohio in 1922 by Judge Paul William Alexander. The name Y's Men (men of and for the Y) came from letters sent home by Will Cressy, a vaudeville entertainer, who was sent overseas by the YMCA during the First World War to entertain the troops. He wrote several articles which he signed "Will M. Cressy, one of the Y's Men of the East." Paul W. Alexander read some of the articles and obtained permission to borrow the term "Y's Men."

- 1923** The first reference in any Y's Men's publication concerning the supportive activities of wives of Y's Men appeared in May 1923 when the question was posed "Is there an organization called Y's Women?"
- 1924** The answer at the time was "No." However, in 1924, the first Y's Menettes Club was established in Vancouver, British Columbia, and the Y's Menettes movement was born.
- 1931** In 1931, at the Cleveland International Convention, the Y's Men's Board of Directors voted to officially endorse the Y's Menettes movement and encourage the organization of more women's clubs.
- 1944** At the 21st Annual International Convention in Sudbury, Canada in 1944, it was decided that due to the expense and organizational structure required, fostering an International Y's Menettes organization was not feasible. This resulted in the focus and involvement of Y's Menettes Clubs being with their local communities and areas.
- 1950** At the International Convention in Mexico City in 1950, Y's Menettes voted to have a "Declaration of Association." With this vote, Y's Menettes sought formality, structure and clarification, with recognition of their existence and purposes.
- 1957** With recognition came the subsequent question, "Who is eligible to be called a Y's Menette?" In 1957 at the Toronto International Convention, the answer was decided and an addition of an article to the Y's Men's Constitution governing Y's Menette membership stated, "Wives of Y's Men shall be known as Y's Menettes which makes them eligible for membership in a Y's Menettes Club, maintaining the Y's Menettes standing of Auxiliary to the Y's Men."
This article declared three premises for the Y's Menettes movement:-
1. That each woman married to a Y's Man, was officially recognized at a Y's Menette.
 2. That as a wife of a Y's Man, that woman could decide to join a structured Y's Menettes Club.
 3. That Y's Menettes Clubs must function as auxiliaries, assisting Y's Men's Clubs with their projects and activities, rather than as completely separate Clubs with diverse involvements.
- 1967** Ten years later, the language of the article was reworded to "Wives of Y's Men shall be known as Y's Menettes.
They are eligible for membership in a Y's Menettes Club, the auxiliary to the Y's Men." The wording was changed; the meaning was not.
- 1970** The growth of Y's Menettes Clubs was successful and consistent. By 1970, there were 364 declared Y's Menettes Clubs in 26 different countries, with the assistance of 24 Regional Service Directors, appointed by their respective Y's Men's Regional Directors.

During the late 1960s, there was much discussion on the status of women and their participation in the Y's Men's movement. An International Task Force was appointed in 1970 to examine various alternatives for Y's Menettes and to present their conclusions. Surveying 118 Y's Menettes Clubs with 1,259 members participating, the message was clear - Y's Menettes overwhelmingly saw their purpose was in helping their Y's Men's Clubs and the YMCA. The survey showed that Y's Menettes Clubs were enthusiastically functioning and membership participation was positive to their Y's Men's Clubs, YMCAs, Communities and to the women involved.

It did not however, address the larger question, "What alternatives exist for women who are not married to Y's Men?" This question could not be answered within the Y's Menettes movement which was still bound to the Constitution definition which required that a Y's Menettes Club member must be the wife of a Y's Man.

1973 Responding to the concern regarding women, a new Y's Men's Constitution was adopted at the Jamaican International Convention in 1973. It stated: "The membership of each local (Y's Men's) Club may consist of men or women or both. There may be Y's Menettes Clubs consisting of women, to serve as an auxiliary to the local Y's Men's Club."

The direction of the Constitution was positive - women were clearly to be given a choice. A woman became a Y's Man or a Y's Menette depending on the Club she belonged to. **The wife of a Y's Man was no longer automatically a Y's Menette** - she could be a Y's Man herself.

Now that their membership was not restricted to Y's Men's wives, Y's Menettes Clubs benefitted from the many other women who joined.

In 1973, the definition of a Y's Menette became, and still is, that:-

"A Y'S MENETTE IS A MEMBER OF A DECLARED Y'S MENETTES CLUB."

With the introduction of women Y's Men in 1973, some Areas/Regions placed emphasis on the creation of mixed Y's Men's Clubs and reduced or withdrew support for Y's Menettes Clubs. Sadly many of these Y's Menettes did not understand that they could choose to remain as they were, and some Clubs founded.

The confusion of Y's Menettes Clubs was understandable when their leadership was so changed by Y's Men International. (See Page 4)

Instead of maintaining an International Service Director for Y's Menettes, a Y's Menette was appointed as Adviser to the Y's Men's International President from 1972 to 1974. This title was changed to

1972 Director of Women in Y'sdom during 1974 to 1977, followed by a two year period when no

1974 International appointment was made.

1977

During these confusing 6 to 7 years, many Y's Menettes Clubs continued to function successfully, clearly demonstrating the choice of their members to remain in Y'sdom as Y's Menettes. Y's Men

1979 International recognized their existence and in 1979 reinstated the position of ISD for Y's Menettes. No files remained, so the greatest task faced then by ISD, Beryl Jones (Australia), was to trace and identify all Y's Menettes Clubs still existing in the world.

1982 Once again, Y's Menettes Clubs appreciated belonging to their reunited worldwide movement. This was further enhanced with the inauguration of the Y's Menettes International Project in 1982. (See Page 28)

1987 In 1987/88, Y's Men International offered to recognize the Y's Menettes movement as full partners in Y'sdom. Y's Menettes Clubs voted to accept this generous offer and to contribute each year (US\$1.00 per member) to a Fund which would cover the travel costs of the Y's Menettes representative (usually ISD or Past ISD) to attend the Y's Men's International Council Meeting (ICM) each July - a seat and voice but no vote.

1988 ISD Christine Bonnevier became the first Y's Menette to officially take part in the ICM in Kyoto in July 1988.

1990 The 1990/91 term of Grace MacDonald (Canada) saw further important changes for Y's Menettes.

1991 Grace made three proposals to the 1990 ICM, then led the Task Force and vote by Y's Menettes Clubs with these results:-

1. The title of the Y's Menettes International Service Director became International Director (ID not ISD).
2. The situation of no vote for the Y's Menettes representative at the ICM was supported.
3. A proposal to change the Y's Men International definition of the role of Y's Menettes Clubs from "auxiliary" to "support" led instead to a totally new definition in the Constitution of Y's Men International:-

"THERE MAY BE Y'S MENETTES CLUBS CONSISTING OF WOMEN TO PLAN AND CARRY OUT PROGRAMMES AND PROJECTS OF THEIR OWN IN SUPPORT OF THE Y'S MEN'S CLUBS, THE YMCA AND THE COMMUNITY AT LOCAL, DISTRICT, REGIONAL, AREA AND INTERNATIONAL LEVELS."

1997 The alternate name for a Y's Menettes Club, Y Service Club (Women), was approved.

1999 The "Y's Menettes Representative to ICM Fund" was renamed the "Y's Menettes General Fund". Further voting finalised the accepted uses of this fund. (See Page 40)

- 2002** Y's Menettes clubs voted to adopt the Mission Statement for Y's Menettes – see below.
- 2003** Y's Men IC Members asked Y's Menettes to appoint their own International Director for each two year term.
- 2009** Y's Men ICM agreed to cover the costs of the Y's Menettes ID to attend the ICM each July.

MISSION STATEMENT

Y's Menettes International is

A vibrant community-based movement that successfully:-

- SUPPORTS** The programs and aims of Y's Men International and the YMCA especially upholding Christian principles.
- ENCOURAGES** Youth activities.
- RESPONDS** to Community needs.
- FOSTERS** International goodwill through support of the Y'S Menettes International Project and participation in the Sister Club Program.
- PROMOTES** Personal development.
- ENCOURAGES** Enjoyment of life.
- KEEPS** Members informed of local, national and worldwide matters within the Movement – and acts accordingly.

Y'S MENETTES INTERNATIONAL LEADERSHIP

International Service Director for Y's Menettes

1952 - 1961	June Lewis
1961 - 1963	Peg Dresser
1963 - 1966	Virginia Logsdon
1966 - 1968	Marlene Ekberg
1968 - 1970	Kassie Nakamura
1970 - 1971	Dee Adams
1971 - 1972	JoAnn Forman

Advisor to the Y's Men's International Director

1972 - 1973	Dorothy Eide
1973 - 1974	Barbara Kehn

Director of Women in Y'sdom

1974 - 1975	Yolanda Apestequi	South America
1975 - 1977	Virginia Fong	Philippines

For two years 1977 - 1979 there was no appointment.

International Service Director for Y's Menettes

1979 - 1981	Beryl Jones	Australia
1981 - 1982	Barbara Cleaver	Canada
1982 - 1983	Jeanie Bostrup	USA
1983 - 1984	Pam Crammond	Australia
1984 - 1985	Mitsuko Sakurauchi	Japan
1985 - 1986	Silvya Reyes de Croci	Uruguay
1986 - 1987	Kazuko Hashimoto	Japan
1987 - 1989	Christine Bonnevier	USA
1989 - 1990	Aleyamma Abraham	India
1990 - 1991	Grace MacDonald	Canada

International Director for Y's Menettes

1990 - 1991	Grace MacDonald	Canada
1991 - 1993	Shirley Unmack	Australia
1993 - 1994	Young Ok Song	Korea
1994 - 1995	Michiko Maeda	Japan
1995 - 1996	Myrna Wolf	USA
1996 - 1997	Marguerite MacEwen	Canada
1997 - 1998	Young Ok Song	Korea
1998 - 2000	Gurli Holm	Denmark
2000 - 2002	Brenda Berry	Australia
2002 - 2003	Florence Gates	Canada
2003 - 2005	Jennifer Cameron	Australia
2005 - 2007	Shanti Panigrahi	India
2007 - 2010	Carol Reynolds	Canada
2010 - 2012	Shoko Fujii	Japan
2012 - 2014	Grethe Baekgaard-Thomsen	Denmark
2014 -	Carole Dunbar	Canada

ABBREVIATIONS

In Y's Men International, the titles of Officers and Programs are often abbreviated.

Throughout this Manual, each title has usually been introduced in full, followed by its use in the convenient abbreviated form.

The following list contains the abbreviated and full titles of many of the Organisation's Officers.

It is helpful to be aware of the letters which refer to the Officer level:-

I = International
 A = Area
 R = Region
 D = District

Other commonly used additions are:

E = Elect (at the end of a title).
 P = Past (at the beginning of a title).

Y's Menettes - Y's Mts.

ID	International Director
IPCo-ord	International Project Co-ordinator
ISCCo-ord	International Sister Club Co-ordinator
A(S)D = AD or ASD	Area Director or Area Service Director
R(S)D = RD or RSD	Regional Director or Regional Service Director
SCC	Sister Club Co-ordinator

Y's Men - Y's M.

IHQ	International Headquarters
ISG/SG	International Secretary General/Secretary General
IP	International President
IT	International Treasurer
ICM	International Council Member (or Meeting)
ISD	International Service Director
YMW Ed	Y's Men's World Editor
AP	Area President
ASD	Area Service Director
RD	Regional Director
RT	Regional Treasurer
RSD	Regional Service Director
DG	District Governor

Y'S MENETTES IN Y'SDOM

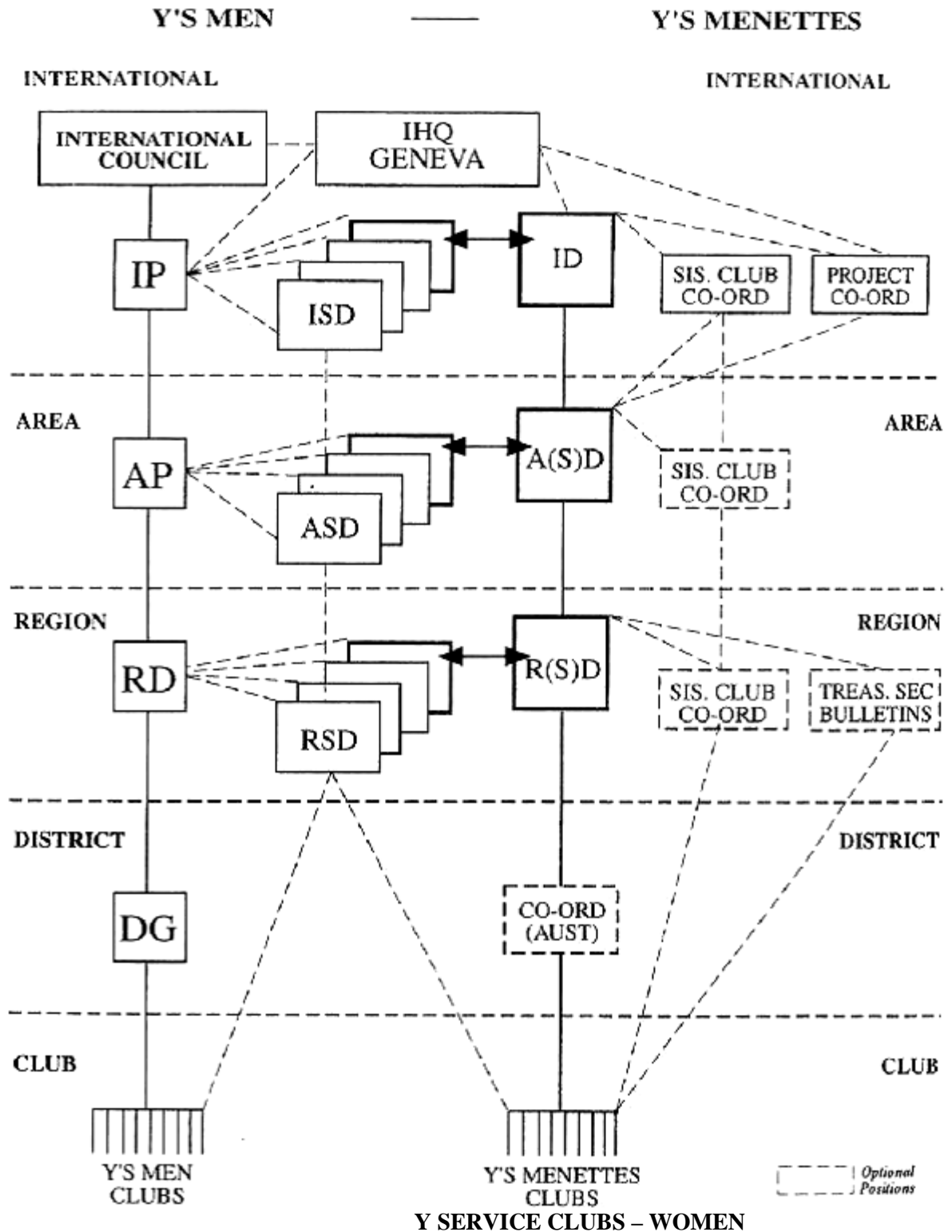

MEMBERSHIP

COMPOSITION OF CLUBS

Y's Menettes Clubs consist of women who wish to uphold the object of the Club. These may be wives of Y's Men or any women who wish to enjoy the fellowship of Y's Menettes Clubs and assist in the projects of Y's Men, the YMCA and the community.

RESPONSIBILITIES

A Y's Menette should:-

- Attend meetings regularly.
- Support the various activities of the club.
- Fulfill her financial commitments by paying her Club fees which are comprised of:-
 - (a) Club expenses, including bulletin.
 - (b) Regional/Area dues (if appropriate).
 - (c) International contribution. These cover the travel costs of the Y's Menettes ID or representative to attend the ICM each year. In 1993 a survey and vote was conducted to determine priorities in using surplus funds.

NEW MEMBERS

Your new member is important. Offer her transport to meetings. Make sure she is not left alone. Include her in Club activities. Provide her with relevant literature e.g. Y's Menettes promotional leaflets, Manual.

Y'S MENETTES AT LARGE

Y's Menettes at Large can be defined as:-

- Y's Menettes no longer residing in communities where a Y's Menettes Club exists. They may become Members at Large upon application and approval by both a chosen Club and the relevant R(S)D.
- Y's Menettes at Large are required to pay Regional/Area and International contributions to their attached Club, together with whatever fees that Club requires to produce and post its bulletins to members.

LINK MEMBERS/FRIENDS

A Link Member has resigned as a Y's Menette, but wishes to retain her interest with the Club. She may do so by paying the necessary fee to receive the Y's Menettes Bulletin.

HONOURING MEMBERS

Some Clubs may wish to confer special recognition on members who have shown outstanding qualities as a Y's Menette. This can be done by one of the following means:-

1. Certificate of Appreciation
2. Life Membership - Life Membership means that a Club accepts continuing full financial commitment for the member it wishes to honour.
3. Endowment Fund - A contribution is made to the Y's Men International Endowment Fund (See P.31)

SUGGESTED AGENDA FOR CLUB MEETINGS

- | | | |
|-----|-----------------------------|--|
| 1. | Welcome and introductions | |
| 2. | Devotions | |
| 3. | Apologies | |
| 4. | Minutes of previous meeting | - confirmation
- business arising |
| 5. | Correspondence | |
| 6. | Treasurer's report | |
| 7. | Committee reports | - Bulletin, Sister Club, Catering, Calling Officer, Social, others |
| 8. | General Business | |
| 9. | Announcements | - Next meeting, hostesses, program etc. |
| 10. | Close meeting | - Y's Menettes Prayer |

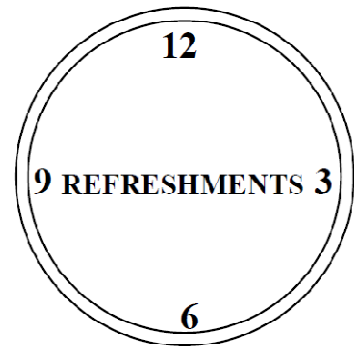
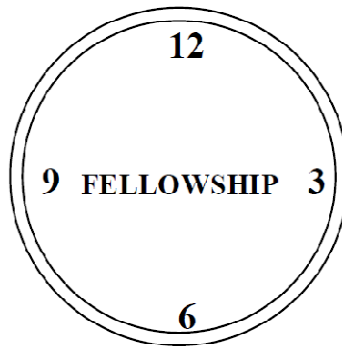
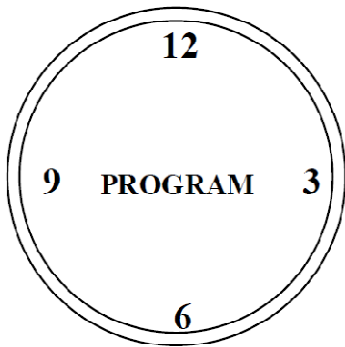

Points to consider

- (a) Executive officers meeting prior to general meeting.
- (b) Secretary to keep President informed of all business requiring attention prior to meeting.
- (c) Prepare and photocopy an agenda form for use by Secretary and President. Leave spaces where appropriate for notes.
- (d) Club members to forward ALL business or correspondence to the appropriate officer prior to the meeting, if possible.
- (e) Secretary to keep a record of inward and outward correspondence, for reference. Inward correspondence to be in precise form, where applicable.
- (f) Consider having guest speaker at beginning of meeting, instead of following business segment.

PROGRAM PLANNING

The important duty of planning Club programs is usually the responsibility of the Vice-President/President Elect. Interesting, informative programs will ensure that Club members will be eager to attend meetings and ultimately become involved in the running of Club affairs.

INTERESTING PROGRAMS WILL:-

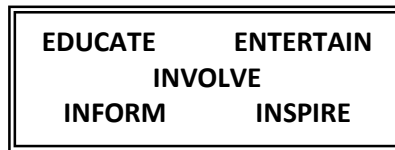

SUGGESTIONS:

1. Prepare a rough plan for the proposed programs for at least six months in advance.
2. Have a standby program on hand at all times as an emergency.
3. Detail, plan and set up in advance all requirements.
4. If the program is a guest speaker/presenter:-
 - (a) Confirm arrangements in advance.
 - (b) Check correct title and background information.
 - (c) Introduce and make welcome.
 - (d) Thank adequately.
5. Involve other Club members - they may help with planning and conducting programs or by introducing or thanking guest speakers. A program committee may be appropriate.
6. Budget for costs involved e.g. small gift, appreciation certificate.

PROGRAMS CAN BE DERIVED FROM MANY SOURCES:

<u>GUEST SPEAKERS</u>	Y'sdom, YMCA, Community services, local personalities.
<u>DEMONSTRATIONS</u>	Arts, Crafts, Hobbies.
<u>MEMBER PARTICIPATION</u>	Games night, Quiz, Play Reading.
<u>VISITS</u>	Local Industry and Services, Museum, Art Gallery.
	Ideas for programs are unlimited.

INTERESTING PROGRAMS CAN ENLIVEN A CLUB AND ENTHUSE THE MEMBERS.

DEVOTIONS

As we are a Christian based organisation embracing a worldwide fellowship of all faiths, devotions/reflections play an important part in the life of each Club.

- HOW** A devotional time should be part of every Y's Menettes meeting. It does not necessarily have to be long and involved - sometimes the simpler the better. However, preparation for this time is important.
- WHEN** Usually at the beginning of the meeting, but some Clubs prefer to close with their Devotion. Just when during the course of the meeting is not so important, the main thing is that it is included.
- WHAT** Many books are available with inspirational material. A Bible reading or similar is appropriate and material can often be found in other Clubs' bulletins (both Y's Menettes and Y's Men's publications.)
- WHO** Usually members are rostered to present their own personal thoughts. This is probably the most satisfactory way of sharing the position enabling most Club members to participate.

Remember that there are often special occasions to think of when preparing devotions and these call for additional thought e.g. Christmas, Easter, special events on the Y's Menettes calendar, illness and bereavement.

Other Y's Menettes gatherings at which some form of devotions should be included are Conventions, Combined Meetings and Changeover Ceremonies.

PRAYERS

Prayer No.1

God bless all Y's Menettes here,
And all whom we hold dear,
As now we pray.

To every Y's Menette far and near
We pledge devotion most sincere;
New zeal our hearts imbue,
And consecrate ourselves anew.
Amen



Prayer No. 2

God bless all Y's Menettes
Here and throughout the world,
We pray for health and happiness
As we work together with a common goal,
We ask Thy guidance in whatever we do,
May Thy guiding light shine on our Y's Men too,
May our friendship be a deep and everlasting one,
As united we work for our Y's Men and Y'sdom.
Amen

Y'S MENETTES SUPPLIES

When Y's Menettes Clubs need assistance in obtaining supplies, they should contact the Y's Menettes ID, usually via their R(S)D or A(S)D.

CHARTER CERTIFICATES

These are held by the Y's Menettes ID and Y's Men ISG as both of these Officers are required to sign each certificate issued. The Y's Menettes A(S)D or R(S)D should communicate with the ID to obtain a certificate for each new Y's Menettes Club to be chartered.

PROMOTIONAL LEAFLETS

A(S)Ds and R(S)Ds should keep supplies of Y's Menettes leaflets for their Clubs and personnel.

In non-English speaking countries, they should arrange for the production of leaflets in the relevant language/s.

Each ID should ensure the continuous supply of Y's Menettes leaflets, arranging for the production of further supplies as appropriate.

BADGES/PINS

In July 1994, Australian Y's Menettes arranged the supply of new badges/pins for Y's Menettes worldwide.

Member Badges/pins

Stick Pin

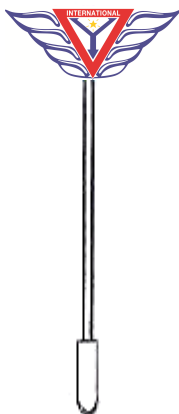

With pin catch



Special purpose badge/pin (blank)

With pin catch



To be engraved by Clubs/Personnel
For special uses (not name pins),
e.g.: Past President (President 1993-94)
Past Director (Regional Director 1992-94)
10/15/20 years service

The Y's Menettes ID should ensure the constant supply of badges/pins and make available price lists and relevant particulars.

Some Y's Men Area/Region Supplies Officers may still hold various Y's Menettes articles including badges/pins which may be of an older design with tie-tack backs.

At Area/Region level, Y's Menettes may arrange to produce material to suit their need e.g. stationery, gift cards, appreciation certificates, spoons. It is essential that the correct Y's Menettes emblem is used at all times. (See Front Page).

BULLETINS

A good bulletin, published on time, is a tremendous asset to your Club. It keeps members informed and interested especially if they happen to have missed the last meeting.

Sent by regular mail or email, it is invaluable as it provides a reminder of events to come and should feature prominently the time, date and place of the next meeting.

Many Regions provide bulletin awards annually, with an award logo printed on subsequent Club bulletins. Guidelines for awards should be set and clearly understood by Clubs in your Region. A points system can be useful.

DISTRIBUTION

Y's Menettes

- Club members
- Y's Menettes at Large attached to Club
- Link Members of the Club
- R(S)D, A(S)D
- Other Clubs of Region/Area
- Bulletin Promoter (if appropriate)
- Region/Area Sister Club Co-ordinator
- Sister Club/s
- International Officers (optional)

Y's Men

- Area President
- Regional Director
- District Governor
- Area/Regional publication (if applicable)
- Relevant Y's Men's Club

YMCA

- Secretary/Executive Officer

INCLUDE



REGIONAL/AREA AND INTERNATIONAL NEWS

IMPORTANT DATES

CLUB ACTIVITIES

LOCAL YMCA NEWS



USE
FRAMING

USE

FIRST AND LAST NAMES
MEMBERS' CONTRIBUTIONS

S P A C I N G

INSTALLATION OF CLUB OFFICE-BEARERS

The following ceremony may be used at the Chartering of a new Y's Menettes Club and for the Changeover of Office-Bearers. It is conducted by the Y's Menettes A(S)D/R(S)D or appropriate officer.

It is most important to make arrangements prior to the ceremony. Each Club is different, and will be seeking guidance and direction to help make the Installation meaningful.

HINTS FOR INSTALLING OFFICER:-

1. Request a copy of the planned program for the function in order to be familiar with proceedings.
2. Ensure that items for the ceremony are available e.g. candles for each participant, lighter/matches, badges, Club banner and Charter displayed.
3. Conduct the ceremony in a position which allows room for Club members and Inductees to be easily seen. If possible use a microphone.
4. The Club Officers and their duties may differ from Club to Club, so it may be helpful to type the Installation Ceremony on cards (postcard size) with names and details of relevant officers pencilled in.
5. A pleasant atmosphere may be created by having the room lights dimmed during an evening ceremony.
6. Before commencing the ceremony the A(S)D/R(S)D may like to express a Vote of Thanks to the outgoing Office-Bearers.

CEREMONY:

With her candle alight the A(S)D/R(S)D says:-

You have been chosen by your Club to be Officers because of your outstanding abilities and dedication in working for your Y's Menettes Club in furthering its service to Y's Men, YMCA and the community.

To be an Officer in the Club means to be enthusiastic and active, to be world minded, and to be unselfish in your thoughts and ambitions for your Club.

As I briefly charge each of you in your Office, you will receive the symbol of the light of Christ.

[Lighting each candle as she installs the Officer]

PRESIDENT, since yours will be the guiding light, may I light your candle first. May it burn even though others should grow dim.

It is important that you encourage Club members to plan and carry out programs and projects in support of Y's Men, the YMCA and the community at all levels.

In accepting this light, you accept the responsibilities of leading the Y's Menettes Club. My God bless and aid you in the fulfillment of these tasks.

VICE-PRESIDENT/PRESIDENT ELECT, with your candle alight, let it remind you that your duty is to support the President in her office and be prepared to assume her duties should the need arise. May the programs you prepare and present for your Club meetings, educate, entertain and kindle enthusiasm among Club members.

SECRETARY, you will deal with the Club's correspondence and assist the President and other officers in carrying out the business of the Club. It is your duty to record and keep the permanent records of the Y's Menettes Club. May the words be preserved in such a manner that they may aid and safeguard the Club in its accomplishments and decisions. Be regular in attendance, accurate in your records, and worthy of the position you hold.

TREASURER, to you falls the necessary work of collecting, paying out and recording accurately the finances of this organisation. Up-to-date accounting gives the Club the ability to generously share monies for various projects and charities.

BULLETIN EDITOR, may the glow of this light reflect in your writings and serve as a means of communication - educating, entertaining and inspiring all who read them. As you share news of your Club, you provide a vital link between Club members and Y's Menettes throughout the world.

JUNIOR VICE-PRESIDENT/COMMITTEE MEMBER, you have the responsibility of arranging rosters of Club members who will act as hostesses and present devotions at Club meetings. As our organisation is a Christian one, devotions are of particular importance and your planning will ensure that Club meetings begin or end with appropriate focus.

MEMBERSHIP OFFICER/CALLING OFFICER, it is your task to care for the members of your Club in times of joy, sorrow or illness. You have the privilege of visiting and introducing prospective new members to the fellowship of Y's Menettes.

[Addressing All Officers]

In accepting the responsibility of Office, you are truly "acknowledging the duty that accompanies every right." To signify this commitment, please raise your right hand and answer "IDO." You hereby pledge your devotion to the ideals and purposes of this Club.

Having made this public avowal, I am gratified to pronounce you Officers of the Y's Menettes Club for the term 20../..

[Addressing ALL Club members, proceed as follows:-]

Will all Club members please stand.

It is impossible for these Officers to lead and successfully direct this Club without the full co-operation of each Club member. As members, I wish to remind you of your duties:-

- *that of cultivating good fellowship throughout Y'sdom,*
- *attending Club meetings and participating in Club activities designed to carry out our purpose,*
- *and co-operating fully with these Officers in performing their duties.*

With this understanding, will you pledge yourselves to accept the challenge for the Y's Menettes Club? If so, please raise your right hand and answer "I WILL."

MAY WE BOW OUR HEADS IN PRAYER:

Heavenly Father, we ask you to kindle a flame of love for our Y's Menettes and Y's Men. Make us kinder, more friendly and more willing to give a helping hand where there is need. We ask your blessings on these Officers in the year ahead. Give them wisdom in the office they hold. We ask this in Thy Name. Amen

**MAY I CONGRATULATE YOU AND PRONOUNCE YOU THE NEW OFFICERS OF THE
..... Y'S MENETTES CLUB**

NEW MEMBER INDUCTION

This ceremony may be conducted by the Club President, or may include other officers/personnel. The Inductee should be contacted prior to the meeting (by the President or an Executive Committee member) and given notice of the intended induction.

PREPARATION

Ensure all items necessary for the ceremony are available:-

- (a) Copies of the ceremony for each participant to read and prepare for a meaningful induction.
- (b) Candles - one each red, white and blue; and one for the Inductee to hold.
- (c) Club banner - placed in a prominent position.
- (d) Gift for Inductee. e.g. welcome folder, flower posy, badge.

LOCATION

Depending on the location of the meeting, consider:-

- (a) Placement of the official table with candles, so that all members can see.
- (b) Where the Inductee will be standing with the club member introducing the Inductee beside her.
- (c) Lighting - it may be possible to dim some of the lighting in the room.

CEREMONY

PRESIDENT:

Tonight we welcome to our Y's Menettes Club. In doing so, I would like to commence our Induction Ceremony by lighting the candles you see before you.

The red candle Symbolizes leadership

The blue candle Symbolizes the acceptance of the charges and responsibilities of our Y's Menettes Club.

The white candle Symbolizes the light of the teachings of Christianity for our world today.

CLUB MEMBER: (Introducing the Inductee)

President, I have much pleasure in introducing who wishes to become a Y's Menette. I believe that she is a worthy candidate to be a member of our Club.

PRESIDENT: (Addressing the Inductee)

....., the Y's Menettes Club of consists of women who are willing to serve the Y's Men International Movement, YMCA and community. As a member you will also benefit from the fellowship which our Club and the movement has to offer.

*The motto of Y's Men International is "**To acknowledge the duty that accompanies every right.**"*

In meeting this challenge you will come to understand the meaning of Y's Menettes.

OFFICER:

The objects of our Club are:-

- *To provide opportunity for personal development.*
- *To cultivate warm fellowship among all Y's Menettes.*
- *To support by active service, programs and projects of the Y's Menettes, Y's Men, YMCA and the community.*

Your obligations to the Club include:-

- *Regular attendance at meetings.*
- *Promptness in meeting your financial commitments.*
- *Involvement in all aspects of Club activities.*

PRESIDENT:

With this understanding, do you pledge yourself to accept the challenge - "To acknowledge the duty that accompanies every right?"

If so, raise your right hand and answer "I do."

PRESIDENT/OFFICER: (Standing beside the Club banner and indicating the emblem).

Having made this solemn pledge you are entitled to understand the significance of the Y's Menettes emblem. The central feature is the Y's Men's emblem:-

The red triangle is the symbol employed by the "Y" to denote its threefold emphasis on SPIRIT, MIND and BODY.

The word INTERNATIONAL indicates the scope of our friendship and the breadth of our purpose.

Within the triangle you will see a gold star shedding rays of light. This star, the star of Bethlehem, guided the three Wise Men of the East to the Christ Child.

So may the golden star in this emblem, which represents the ideals of our Club, serve as a constant guide to the Y's Menettes of today.

OFFICER/OTHER MEMBER:

And now, as President lights your candle from the blue candle, you are accepting the charges and responsibilities as a member of the Y's Menettes Club and the International Y's Menettes movement.

PRESIDENT:

I am honoured to pronounce you a Y's Menette and extend to you the best wishes and friendship of the Y's Menettes Club.

The new Y's Menette may be presented with appropriate mementoes e.g. badge, welcome folder, flowers etc.

ALTERNATIVE NEW MEMBER INDUCTION

(Used by the Y's Menettes of Denmark)

In this ceremony, three candles are also used. Placed in a three-armed candlestick, they symbolize SERVICE, TOLERANCE AND FAITHFULNESS - words which all begin with "T" in Danish.

The President conducts the Induction while the Vice-President lights the candles in turn.

CEREMONY:

Today we have the pleasure to admit a new member in the Y's Menettes Club. It is (name). For some time you have been a guest at our meetings and arrangements, and you have had the opportunity to learn about the Y's Menettes Club and to know its members. You have become acquainted with the goals of Y's Menettes, and you have seen how we work with our tasks.

At the same time we have learned to know you, and when we have seen that you are interested in our Club, the Presidium - with your consent - decided to admit you as a member of our Club.

Now we will use three candles, symbolizing the three words Service, Tolerance and Faithfulness.

The first I mention is SERVICE (the Vice-President lighting the candle on the right) because we are a support for Y's Men, and because we want to serve our Lord and our neighbour. You see it is a service for others.

The next word is TOLERANCE - we will save it for a little while.

The third word is FAITHFULNESS (the Vice-President lighting the candle on the left). Faithfulness is what we want you to show our Club.

Now you see that the middle word TOLERANCE enters into the picture. (the Vice-President lighting the middle candle) With tolerance, we show respect for the beliefs and needs of others, therefore we need to put it in the middle.

These candles signify SERVICE, FAITHFULNESS and TOLERANCE.

To show that you are now a member of our Club, we want to give you our emblem.

(The symbols of the emblem are described here as in the other Induction ceremony).

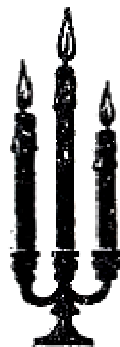

CLUB CONSTITUTION

SUGGESTED CONSTITUTION AND GUIDELINES (Local Clubs should adapt and complete to suit their own needs.)

THE Y'S MENETTES CLUB OF _____ INCORPORATED *

CHARTER DATE _____
REVISED DATE _____

ARTICLE 1. - NAME:

The name of the organisation shall be the Y's Menettes Club of _____ Inc.*

ARTICLE 2. - OBJECT:

The object of the Club shall be:-

1. SERVICE - To plan and carry out programs and projects of its own in support of Y's Men's Clubs, the YMCA and the community at Local, District, Regional, Area and International levels.
2. FELLOWSHIP - To encourage good fellowship among Y's Menettes and Y's Men everywhere.
3. PERSONAL DEVELOPMENT - To provide opportunities for members to develop personal skills.

ARTICLE 3. - MEMBERSHIP:

Y's Menettes may be any women who wish to uphold the Object of the Club.

1. A Y's Menette will always retain her membership as long as she remains financial and active.
2. If her membership lapses, she shall not rejoin without prior approval of the Executive of the Y's Menettes Club of _____ Inc.*
3. A new member is required to attend three (3) meetings and may be inducted at the third or next meeting.
4. Should a Y's Menette cease to be an active member she may apply for:
 - (a) Y's Menette At Large membership. (See Page 8)
 - (b) Link Membership. (See Page 8)

ARTICLE 4. - MANAGEMENT:

The executive committee shall consist of President, Secretary, and Treasurer. It may include Vice-President/ President Elect, Membership Officer, Bulletin Editor and such other members as determined by the Club.

The members of the executive shall serve for one (1) year, and shall be eligible for re-election at the end of that period with a maximum of _____ consecutive years in any one position.

ARTICLE 5. - FINANCE:

1. Membership subscriptions shall cover Club expenses, Regional, Area and International commitments.
2. An account shall be maintained at the _____ (bank) in the name of Y's Menettes Club of _____ Inc.* The Treasurer shall deposit therein, all monies received within seven days of their receipt.
The account shall be drawn against only by orders signed by any two of the following:- President, Secretary or Treasurer.
3. The financial year of the Club shall end on the last day of _____ in each year.
4. The Treasurer shall present an audited annual financial report at the Annual General Meeting.
5. An auditor shall be appointed at the AGM for the forthcoming year.

* **Incorporation** (See Page 21)

ARTICLE 6. – MEETINGS:

1. The regular meetings of the Club shall be held on the _____ of each month, or as notified. Should that day be a holiday or other special occasion, the executive may alter the date as convenient.
2. Executive committee meetings may be held prior to each general monthly meeting.
3. An Annual General Meeting of the Club shall be held _____.

ARTICLE 7. - ELECTIONS:

The Officers of the Executive Committee shall be appointed as follows:-

1. Nominations sought from Club members.
2. Approval given by nominees.
3. Election conducted for positions if necessary.
4. Installation of successful candidates at Annual Meeting or Changeover function.

ARTICLE 8. – COMMITTEES:

The Executive Committee may appoint such committees as are deemed necessary for the efficient running of the Club.

ARTICLE 9. - QUORUM:

_____ % of the members of the Club shall constitute a Quorum.

ARTICLE 10. - AMENDMENTS:

The Constitution may be amended at any regular meeting of the Club by a two third vote of members present, provided that written notice of the amendment shall have been circulated to all members _____ days prior to the meeting.

ARTICLE 11. - DISBANDING:

In the event of the Club disbanding, it shall:-

1. Notify R(S)D and return Charter.
2. Honour all debts and liabilities.
3. Distribute all remaining assets appropriately to Y'sdom, YMCA and/or community, and close account/s.

ARTICLE 12. - GUIDELINES:

The members of the Club shall have power to adopt such guidelines as are consistent with the Constitution for the conduct of business of the Club.

GUIDELINE NOTES

In addition to the basic Constitution, each Club is advised to formulate guidelines appropriate to its individual needs. Your Club can add, delete or amend guidelines at any regular Club meeting by motion - alterations to a Constitution can be a more complex procedure.

It is important that the guidelines be documented in such a way to include the small details which can so often be overlooked e.g. who is responsible for:-

1. *Contacting the new member, arranging transport if necessary.*
2. *Details for Installation/Induction ceremonies.*
3. *Policy on gifts, cards, flowers etc.*

The guidelines should include the duties of officers and committees.

GUIDELINES

DUTIES OF OFFICERS:

1. **PRESIDENT**
The President shall preside at all meetings of the Club and the Executive Meetings. She shall represent the club officially.
2. **VICE-PRESIDENT/PRESIDENT ELECT**
The Vice-President/President Elect shall assume all duties of the President in the absence or incapacity of the President. She shall arrange Club programs.
3. **SECRETARY**
The Secretary shall keep the minutes of the Club and handle all correspondence for the Club. She shall keep an accurate record of the members' names and addresses and a permanent file of all correspondence and records of value to the organisation.
4. **TREASURER**
The Treasurer shall keep a complete account of all receipts and disbursements, collect dues/fees, and pay out funds.

DUTIES OF OFFICERS AND COMMITTEES MAY INCLUDE:-

<u>JUNIOR VICE-PRESIDENT</u>	Appoint home and hostesses for meetings and arrange for devotions.
<u>BULLETIN EDITOR</u>	Produce and distribute bulletin/newsletter monthly if possible.
<u>MEMBERSHIP OFFICER</u>	Contact prospective new members, care for others in time of joy, illness or sorrow.
<u>SISTER CLUB</u>	Arrange regular contact with your Club's Sister Club/s, report to members at Club meetings.
<u>PUBLICITY</u>	Provide information of Club activities or special achievements to local media. Use Y's Menette leaflets when possible.
<u>HISTORIAN</u>	Compile and maintain an album/scrapbook of photos, reports, newspaper clippings featuring Club activities.
<u>SOCIAL</u>	Plan and organise social events for members, families and friends.

*** INCORPORATION**

The membership of our movement involves many voluntary service projects within the community. To maintain these projects, it is necessary for us to become involved with fund-raising, which can incur an added risk for our members being held personally responsible for any litigation which may arise from injury or damage to other people. Club Incorporation is recommended to avoid litigation of individual members. Each Club should investigate the Incorporation laws relevant to its country. To obtain information on becoming an Incorporated Club, contact the Y's Men's Club, local YMCA or the Corporate Affairs Office in your capital city.

DISBANDING A CLUB

It is the duty of the Club officers to inform the Regional/Area (Service) Director of any problems or events leading to the proposed disbanding of a Club. Should the Club take action to disband, the Club Charter must be returned to the Regional (Service) Director, who should notify the Area (Service) Director and International Director of Y's Menettes.

International Association of Y's Men's Clubs

Y's Menettes International



CHARTER

It is hereby declared that this charter is granted to those women who are united in the mutual aim to form

*Insert Name of Club
In this
Space*

The purpose of this Club is to plan and carry out programmes and projects of its own in support of the Y's Men's Clubs, the YMCA and the community at the Local, District, Regional, Area and International levels.

This Club is duly chartered under the Constitution & By-laws of, and in partnership with, the International Association of Y's Men's Clubs.

Charter issued on (Date to be inserted here)

By: Y's Menettes International Director

(Type/insert name of person)

Attested by: Y's Men's International Secretary General

(Type/insert name of person)

Charter Certificate Presentation date: (Date to be inserted here)

CHARTERING A NEW Y'S MENETTES CLUB

There are three main avenues for the extension of the Y's Menettes movement.

New Clubs may develop:-

1. When Y's Men move into a new locality/District/Region. **The establishment of Y's Menettes Clubs should be offered as a viable option for the involvement of women in Y's Men International.**
2. If a 'men only' Y's Men's Club exists with no corresponding Y's Menettes Club.
3. If a 'stand alone' Y's Menettes Club is proposed. This may be encouraged by a YMCA.

CONTACT POINTS MAY BE:-

Y's Menettes Directors
Existing Y's Menettes Clubs
Y's Men Personnel e.g. DG, RD, RSD Extension
Y's Men's Clubs
YMCA Directors

PURPOSE:

To offer members the fellowship of a Y's Menettes Club with the opportunity to provide assistance to Y's Men, the YMCA and the community, within the broader framework of Y's Men International.

New Clubs generally enjoy the sponsorship of an existing Y's Menettes Club or Y's Men's Club. The sponsoring Club's input is vital as a source of information, encouragement and a sense of belonging.

SPONSORING CLUBS: in conjunction with the R(S)D/A(S)D should:-

1. (a) Contact interested people and arrange an informal meeting. A sponsoring Club Officer or R(S)D/A(S)D could chair the meeting.
(b) Explain the aims and purposes of Y's Menettes.
(c) Provide interesting promotional material and have the Y's Menettes Manual available.
(d) Explain how Y's Menettes meetings are conducted. i.e. venues, frequency, program, hostesses.
2. (a) Keep in touch by phone, mail, bulletins and visits where possible.
(b) Have Y's Men, Y's Menettes and YMCA Directors for guest speakers.
(c) Encourage interaction with Y's Men, if appropriate.
(d) Help arrange an initial minor service activity.
3. (a) Help formalise the Club - encourage the appointment of an Executive Committee.
(b) Explain fees and commitments.
(c) Assist with drawing up the Club Constitution. (See Page 19)
(d) Encourage the proposed Club's Executive to apply to the R(S)D for approval and processing of the Charter. Complete the Club charter application form (Page 46) and send to the R(S)D. The R(S)D contacts the ID for a charter certificate, either via the A(S)D or notifying her of the application. (Sufficient time must be allowed for this to be signed by the ID and Y's Men ISG).
(e) Assist in planning the Charter Ceremony.
(f) Obtain appropriate Member and Officer pins/badges.

CHARTER CEREMONY:

A formal ceremony is usually conducted. It may be a Y's Menettes Club Charter or a combined ceremony, if both Y's Men and Y's Menettes Clubs are to be chartered. The R(S)D/A(S)D and sponsoring Club should ensure that the ceremony takes place at a suitable venue and in a dignified manner.

Generally the R(S)D/A(S)D will:-

1. Induct the new Y's Menette members.
2. Read and present the Charter to Club members.
3. Induct the incoming Office Bearers.

Opportunities should be allowed for special greetings and presentations, fellowship and/or entertainment.

The R(S)D/A(S)D and sponsoring Club should maintain contact with the new Club after chartering.

Y'S MENETTES SISTER CLUB PROGRAM

The program of Sister Clubs was officially recognized in 1965.

Since that time many Clubs throughout the world have been able to learn more about each other's clubs, families, cities, countries and differing cultures, by participating in this interesting program.

Many members take the opportunity to meet together at International Conventions to share a meal together, exchange souvenirs of their countries and also include a visit to a Sister Club while on interstate or overseas tours.

Contact your Area/Region Sister Club Co-ordinator or A(S)D/R(S)D:-

- (a) If your Club wishes to establish a Sister Club link. (Use form.....See Page 26)
- (b) If your Club is experiencing problems.

THE FOLLOWING SUGGESTIONS MAY ASSIST YOUR CLUB'S INVOLVEMENT IN THE SISTER CLUB PROGRAM

1. Appoint a Sister Club correspondent, willing to give two (or more) years service, which provides a consistent address.
2. Allow for finance in your Club budget, to cover the cost of postage, photos, gifts etc.
3. Email is an effective way of sharing bulletins and club news. Send your club bulletins monthly, if possible. Always attach a personal note, if you do not have time to write more fully.
4. Share the duty of letter writing between Club members.
5. Send a photo of Club members, list names as they appear in the picture. Attach a list of members' names and addresses. Suggest your Sister Club members choose their own "pen pal sister" from the photo and write personally.
6. Ask each club member to provide a small lightweight article (handkerchief, bookmark, picture etc.) with name and address attached. Send the parcel to your Sister Club, suggesting that the Y's Menette accepting an article write to the sender in return for the article received.
7. Make one of your meetings a Sister Club night, use music, food, clothes, pictures etc. from the country your Sister Club belongs to.
8. Exchange an album of information, including maps, photos etc., of your Club activities, your community and your country. Try sending a tape of music (folk songs), a video of a special club project, festival or performance from your city.
9. Do not wait for a reply from your Sister Club. Try to correspond regularly. If you are experiencing difficulties, contact your Region/Area Sister Club Co-ordinator or A(S)D/R(S)D who will contact the International Sister Club Co-ordinator.
10. Present a report each month at your meeting and let your Bulletin Editor have items of interest for your monthly bulletin.

**Y'S MENETTES
INTERNATIONAL SISTER CLUB CO-ORDINATOR**

JOB DESCRIPTION

The International Sister Club Co-ordinator is appointed by the Y's Menettes International Director and works in close co-operation with her.

Ideally a term of two years is recommended.
This may be extended at the discretion of the ID.

The International Sister Club Co-ordinator is responsible for the conduct and promotion of the Sister Club Program.

The objective is to encourage understanding between Y's Menettes of different cultures.

COMMUNICATION

Communicate with Area/Region Sister Club Co-ordinators or A(S)Ds/R(S)Ds worldwide to:-

1. Identify Clubs requiring a Sister Club link.
2. Match and introduce Clubs.

When matching Clubs from different countries be aware of language difficulties.

Be prompt in helping Clubs experiencing problems with contacts.

Compile an annual report in liaison with ID. A map may be useful.

Contact with Y's Men Brother Club ISD may also be helpful to the Sister Club Program.

FINANCE

Keep details of expenses and submit to IHQ for re-imburement.

GENERAL

Keep up to date files of current Sister Club links and relevant particulars.

Be prepared to assist with Sister Club presentations at Conventions and/or meetings.

Hand over files promptly to your successor. Include any helpful suggestions and a summary of activities from your term.



Y'S MENETTES SISTER CLUB APPLICATION FORM

Photocopy, fill in clearly and send to the Region/Area Sister Club Co-ordinator (or R(S)D/A(S)D) who will forward it to the International Sister Club Co-ordinator.

Y's Menettes Club: _____ **Charter Date:** _____

Region: _____ **Area:** _____

Locality – City/Town: _____ **Number of members:** _____

Main activities i.e. service, social programs: _____

CLUB CONTACT PERSON – President, Secretary or Sister Club Correspondent (indicate)

Name: _____

Address: _____

PRESENT SISTER CLUB LINKS (if any):

Club:	Region:	Area:	Satisfactory Contact?
1. _____	_____	_____	Yes/No
2. _____	_____	_____	Yes/No
3. _____	_____	_____	Yes/No
4. _____	_____	_____	Yes/No

Any Further comments: _____

CLUB PREFERENCES FOR A NEW SISTER CLUB:

Country/Region/Area

Choice 1: _____

Choice 2: _____

Choice 3: _____

Languages in which Club can communicate: _____

Frequency of communication desired, e.g. monthly, 6/5/4/3/2 per year: _____

Any further comments / considerations: _____

Application Date: _____

CALENDAR

AREA

Each Area should produce a Calendar to be included in the Area supplement to this Manual. It should contain such Area/Region reminders as the dates for:-

- Financial Commitments
 - Dues - Region/Area, International
 - Contributions to Y's Menettes/Y's Men Projects and Programs.

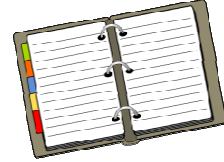

Conventions

Area/Regional activities/combined meetings.

Mark your calendar

Report deadlines.

CLUBS

Clubs should take the Area Calendar and add such reminders as:-

- First meeting of the year.
- New Office Bearers - nominations, elections, installation.
- Annual meeting.
- Club financial commitments.
- Any special Club projects and activities.

JANUARY	FEBRUARY	MARCH
	TOF	Nomina- tions
APRIL	MAY	JUNE
15 Reports Elections	Officers Training	Annual Meeting
JULY	AUGUST	SEPTEMBER
Int'l Convention	Theatre Night	Reg. Convention
OCTOBER	NOVEMBER	DECEMBER
Pot Luck Dinner		Christmas Party

VOTING

When Y's Menettes need to decide on an important matter, at Regional, Area or International level, the most effective method is to conduct a democratic Club vote.

The relevant Y's Menettes Director should supply each Club with the appropriate information and a voting paper. To register a valid vote, each Club must respond correctly by sending its vote directly to the named Officer by the due date.

Previous voting papers should be in the Directors' files for reference.

This is the method employed to choose the International Project which Y's Menettes will support each two years.

Y'S MENETTES INTERNATIONAL PROJECT

This Project was originated by International Service Director, Jeanie Bostrup, USA, with the purpose of uniting Y's Menettes around the world, working together towards a specific goal.

1982 The idea of the Project was presented to Y's Menettes attending the 55th Y's Men International Convention held in Seoul, Korea in 1982, and Dorothy Eide, USA, became the first Project Co-ordinator.

The World Alliance of YMCAs in Geneva provided details of projects which could benefit from Y's Menettes financial support, and a committee of delegates to the Convention made the decision to help children from an orphanage in Sri Lanka. The target to raise US \$6,000 during a period of two years was successfully achieved.

1984 Early in 1984, project information and voting slips were distributed to Clubs around the world via the Y's Menettes Area Service Directors, thus allowing all Y's Menettes to choose the next Project.

Since then, each Project has been concluded, and the new Project and Co-ordinator have been announced, during a Y's Menettes session of the Y's Men's International Convention.

The Y's Men International Secretary General administers the Project funds at Y's Men IHQ, receiving all donations and forwarding progress payments to the selected projects.

For Y'S MENETTES INTERNATIONAL PROJECTS TO DATE - See appendix.

Y'S MENETTES INTERNATIONAL PROJECT CO-ORDINATORS

1982 – 1984	Dorothy Eide	USA
1984 - 1986	Yuko Suzukida	Japan
1986 - 1988	Silvya Reyes de Croci	Uruguay
1988 - 1990	Silvya Reyes de Croci	Uruguay
1990 - 1992	Christine Bonnevier	USA
1992 - 1994	Barbara Hainsworth	Canada
1994 – 1996	Barbara Hainsworth	Canada
1996 - 1998	Shirley Unmack	Australia
1998 - 2000	Shirley Unmack	Australia
2000 - 2002	Carol Hill	USA
2002 - 2005	Barbara Kilburn	Canada
2005 – 2008	Mary Kuruvila	India
2008 – 2010	Shirley Unmack	Australia
2010 – 2012	Kumiko Nishimura	Japan
2012 – 2014	Gurli Holm	Denmark
2014 – 2016	Gurli Holm	Denmark

**Y'S MENETTES
INTERNATIONAL PROJECT CO-ORDINATOR**

JOB DESCRIPTION

The International Project Co-ordinator is appointed by the Y's Menettes International Director for the two year duration of the Project.

The Co-ordinator is required to promote the Project, acknowledge the donations given, monitor the payments made to the chosen project/s and share progress reports.

COMMUNICATION

Obtain information for the Project from the Y's Menettes International Director and liaise with her by forwarding copies of all Project correspondence.

Prepare promotional material e.g. leaflets featuring photographs and descriptions of the project/s to be supported. For further information, contact Y's Men International Headquarters or the Project recipient/s directly.

Distribute material to all Clubs via Y's Menettes Area (Service) Directors or Regional (Service) Directors as appropriate.

Additional promotional material and/or progress reports may be distributed during the second year of the Project.

Keep each relevant Y's Men Area President informed of Projects being supported in his/her Area.

FINANCE

Encourage all clubs to send donations to Y's Menettes A(S)Ds, who will forward the total contributions directly to IHQ before May 31, with details to the Y's Menettes ID and Project Co-Ordinator. (Some Regions may arrange to forward their contributions via the Y's Men Regional Treasurer).

Acknowledge donations from Clubs/Regions/Areas when notified by IHQ.

Liaise with IHQ to monitor progress payments being made to the chosen Project/s.

Keep details of all expenses incurred with preparation and distribution of Project material. Forward to Y's Men's International Secretary General for reimbursement.

GENERAL

Keep details and files of the Project up-to-date.

Prepare a report of the concluding Project for presentation to the Y's Menettes session at the Y's Men International Convention. This report should then be circulated to all Clubs by ID/new Project Co-ordinator.

Forward files promptly to your successor, include any helpful suggestions.

SPECIAL PROGRAMS/PROJECTS **OF Y'S MEN INTERNATIONAL**

Y's Menettes are encouraged to support several important Programs of Y's Men International. Each program is conducted by a Y's Men team of Service Directors at International, Area and Regional levels. For further information regarding any of these programs, Y's Menettes Clubs should contact their relevant Y's Men RSDs.

Many of these Y's Men RSDs already include the Y's Menettes Clubs of their Regions on their mailing lists - this should be encouraged.

ALEXANDER SCHOLARSHIP FUND (Alex Fund/ASF)

This Fund was named for the movement's founder, Judge Paul William Alexander, and began at the 1954 International Convention in Lansing, Michigan, USA.

The purpose of the Fund is to assist financially in the training of YMCA staff and personnel involved in youth training and programs, and may defray some of the expenses of YMCA delegates attending seminars, conferences and conventions.

In each Area of Y'sdom, 90% of the finance raised for this Fund is retained and used in the Area, while 10% is sent to International where it supports YMCA leadership training programs in needy parts of the world.

BROTHERHOOD FUND (BF)

Finance is raised for this Fund by the collection and sale of used postage stamps and by cash donations. Special Y's Men International awards are given to Clubs which achieve certain high levels of points for their stamp and cash contributions.

Originally known as the Bishop's Fund, it was established in 1931 to provide travel finance for selected Y's Men to visit other Y'sdom Areas for such purposes as conventions, meetings, training sessions and club visitations.

It is a wonderful opportunity for wider personal experience, leadership training and international understanding throughout the Y's Men Areas and Regions.

Each year the BF Expenditure Committee plans a balanced program of full and partial grants for visitations between the Areas of Y'sdom. This is promoted to Clubs and a Y's Man or Y's Menette may apply for an advertised BF grant through his/her Y's Men Regional Director. The RD will consider the support of the applicant's Club to the Fund. Delegates are usually chosen on their potential to bring the greatest benefit to the Movement.

Over the years, several Y's Menettes have been awarded BF grants. When a Y's Menette is a BF recipient, the host Y's Menettes Clubs and personnel should be encouraged to assume responsibility for the visitation arrangements.

TIME OF FAST (TOF)

This program evolved from earlier fund-raising efforts of Y's Men International to assist special needy world projects.

Since the early 1970's, Y's Men and Y's Menettes have been urged to 'skip' a meal or two each year and to donate the meal costs saved to this special Fund. Other donations are also encouraged.

Every year the considerable finance raised is carefully allocated to support YMCA Projects in underprivileged areas of the world, in close liaison between the World Alliance of YMCAs and Y's Men International.

The Y's Menettes International Project is similar to a Time of Fast Project. (See Page 28).

ENDOWMENT FUND

Created in 1959, this Fund has two distinct functions.

1. Individuals, Clubs and groups within Y's Men International are encouraged to make contributions to the Fund as a suitable way of honouring present or deceased members or friends of Y'sdom.
For each gift of a determined value, the donor is invited to send a written tribute for the person/s being honoured.
This is then inscribed in Y'sdom's special Golden Book, which is kept at International Headquarters in Geneva. Several Y's Menettes Clubs have bestowed an honour in this manner.
2. The Fund is designed to benefit the Y's Men's movement in special circumstances by providing:-
 - (a) Resources for Extension and Development especially into new Regions.
 - (b) Emergency funds if tragedy should strike one of our Areas or Regions.
 - (c) Funds for special problems or projects.

The Endowment Fund Trustees and the International Council are jointly responsible for the investment and management of the Fund, of which only the interest is used while the principal remains untouched.

YOUTH EXCHANGE PROGRAMS

There are two different exchange programs of Y's Men International, each run quite separately by its own team of Directors.

Children of Y's Men and Y's Menettes may apply to take part in the Youth Exchange Programs of Y'sdom to visit another country.

A suitable young person is permitted to take part in both exchange programs at different times.

For an exchange to take place, a Y's Men or Y's Menettes Club must agree to be the Host Club and accept its responsibilities for the young person involved. Its most important role is to provide home stay with families of Y's Men or Y's Menette members of the Club.

Both Program Manuals contain valuable information for prospective exchange students, host families, sponsor and host Clubs.

1. **YOUTH EDUCATIONAL EXCHANGE PROGRAM (YEPP)**

This traditional program caters for youth, 16-18 years of age, who generally stay for a year in the exchange country and are required to attend school there.

The YEPP Manual contains much valuable information for prospective exchange students, host families and sponsor and host Clubs.

Several Y's Menettes Clubs have very successfully hosted a YEPP student.



2. **SHORT TERM EXCHANGE PROGRAM (STEP)**

This program was introduced in 1992.

It caters for young people, 14-21 years of age, who arrange to stay with a Y's Men or Y's Menettes Host Club for only 2-11 weeks.

They do not attend school but should participate as volunteers in some Y'sdom/YMCA projects/activities.



CONVENTIONS

Throughout Y's Men International, Conventions are held regularly at International, Area and Regional levels:-

International Conventions are held every two years, during July of even numbered years.
Each Y'sdom Area and Region usually holds Conventions annually or biannually to suit its circumstances.

Conventions provide opportunities for:-

Meetings for leaders to train and plan for their roles.
Fellowship among all members attending.
Sharing of ideas/information.
Inspiration and motivation.

As the partner movement in Y's Men International, Y's Menettes need to be an integral part of each Y's Men Convention:-

1. The Host Convention Committee should include Y's Menettes representatives.
2. Key Y's Menettes personnel may be involved in the total Convention program as speakers, report presenters, and forum panel leaders.
3. The Convention program should include separate Y's Menettes session/s.
4. Y's Menettes should participate in all aspects of the Convention.

The needs of the member Y's Men and Y's Menettes should be given priority over the needs of non-member participants at any Y's Men Convention.

THE ROLE OF THE Y'S MENETTES DIRECTOR

At each International, Area and Regional Convention, the relevant Y's Menettes Director (ID, A(S)D, or R(S)D) is responsible for the Y's Menettes involvement in the Convention program.

Prior to the Convention

1. Liaise with the Host Convention Committee and relevant Y's Men leader (IP,AP or RD) to arrange:-
 - (a) Suitable time/s and venue for the Y's Menettes session/s.
 - (b) Any Y's Menettes input in the total Convention program.
2. Promote and encourage Convention attendance.
3. Plan all aspects of the Y's Menettes session/s:-
 - (a) Seek Agenda items from Areas/Regions/Clubs.
 - (b) Plan the Agenda and prepare copies.
 - (c) Contact and assist all personnel taking a special part, i.e. secretary, guest speakers, those presenting devotions, giving reports and making awards. (Each Director may arrange for the assistance of key local Y's Menettes personnel).
 - (d) Ascertain the equipment required and arrange for its provision e.g. slide projector and screen, video recorder, clip board/paper/pen to record attendance.
 - (e) Plan for relevant displays including Y's Menettes supplies.

During the Convention

1. Check the venue for the Y's Menettes session/s.
2. Ensure that all equipment is ready.
3. Have displays set up.
4. Distribute Agendas to all Y's Menettes and interested women attending.
5. Conduct the Y's Menettes session/s - have the proceedings and attendance recorded.

After Convention

1. Arrange for the production and distribution of Session/s Minutes.
2. Follow up any relevant matters.

CONVENTIONS (Continued)

AGENDA SUGGESTIONS FOR THE Y'S MENETTES SESSION/S

(Refer to the Minutes of the previous Convention Session/s.)

Welcome

Introduction/Roll Call - record attendance on circulated list.

Apologies/Greetings

Devotions

Minutes of previous Convention session/s - accepted, business arising.

Relevant Reports - e.g. Director, International Project, Sister Clubs.

Awards

Business/Agenda items

Speakers/Entertainment

Y's Menettes Prayer

ROLE OF Y'S MENETTES HOST CLUB - at Area and Regional Conventions.

In co-operation with the Y's Menettes A(S)D or R(S)D and the Host Convention Committee, the Host Club may:-

1. Supply a bag/folder for each Y's Menette attending.
2. Arrange a Y's Menettes/womens' luncheon.
3. Supply suitable decor at Y's Menettes/Convention venue/s.

INDUCTION OF Y'S MENETTES R(S)D/A(S)D

As the Y's Menettes R(S)D is part of the Y's Men Regional Director's team of RSDs, she is usually inducted into her office when the RD inducts his/her complete team of RSDs. This may take place at a Regional Convention.

If this does not occur, the outgoing Y's Menettes R(S)D may induct her successor at an appropriate Y's Menettes gathering. She may adapt the wording of either the Y's Men RSD Induction ceremony or the Y's Menettes Club Officers Installation.

Similarly, the Y's Menettes A(S)D may be inducted by the Y's Men Area President with his/her team of ASDs, or by the outgoing A(S)D (as for the R(S)D).

**Y'S MENETTES
REGIONAL (SERVICE) DIRECTOR ***

JOB DESCRIPTION

The Y's Menettes Regional (Service) Director is the leader of the Y's Menettes Clubs in her Region and is responsible for promoting the conservation and extension of the Y's Menettes movement in the Region.

She may be elected by the Y's Menettes of the Region, or may be appointed by the Y's Men Regional Director.

The Y's Menettes R(S)D is a member of the Y'sdom Regional team and must be prepared to be the representative/spokeswoman of the Y's Menettes of the Region.

She usually holds this office for one or two years.

(* In some Y'sdom Regions, the word SERVICE is not part of this Y's Menettes' title.)

COMMUNICATION

Main lines of communication for Y's Menettes R(S)D.

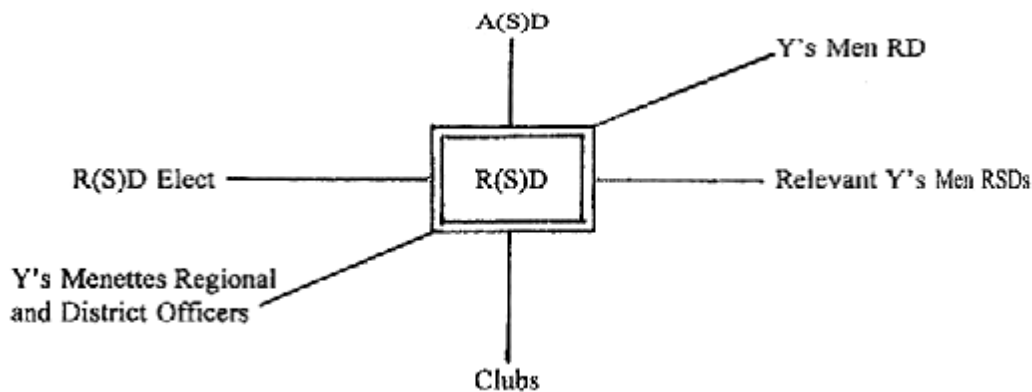

1. Distribute Newsletters, three or four per year, to above network. They should contain information regarding current programs and projects of Y's Menettes, Y's Men and YMCA:-
Regional conventions, meetings, camps, district events, news of clubs/members/special achievements.
International and Area information from A(S)D/ID.
2. Distribute material sent by ID and A(S)D for Clubs. eg ID Newsletters, Y's Menettes Project information and voting papers.
3. Maintain regular correspondence with the Y's Menettes Clubs and A(S)D, the Y's Men RD and other personnel in the network as appropriate.
4. Provide R(S)D Elect with copies of correspondence and information relevant to her coming R(S)D term.
5. Supply a Y's Menettes article for any Regional Y'sdom publication.
6. Promote the support of the Y's Menettes International Project and the various programs of Y's Men International.

REPORTS

Distribute annual report forms to Clubs (See Page 41) to allow for completion and return to you by due date (April 15).
Using R(S)D report forms, (See Page 43)

- (a) Collate information from returned Club forms.
- (b) Record Y's Menettes Regional events and information.

Send complete R(S)D report to Y's Menettes A(S)D by due date (May 1) with copies to Y's Men RD and other relevant personnel. Be prepared to present this report at the Y's Men Regional Annual Meeting.

RECORDS

Compile a Regional Membership Register which lists:-

- Y's Menettes names/addresses/phone numbers for each Club.
- Each Club's office bearers.
- District, Regional, Area Y's Menettes personnel.
- Y's Men RD, DGs, RSDs as appropriate.

Keep the Register current with members' inductions and resignations.

Supply a copy of the register to each Club and relevant personnel.

Keep accurate and up-to-date records of all correspondence and important Y's Menettes material.

Hand over the files promptly to your successor.

Share suggestions for changes/improvements.

MANUAL

Ensure that each Y's Menettes Club of the Region has a copy of the Y's Menettes International Manual.

Where necessary arrange translation of the Manual so each Y's Menettes Club in the Region has a copy in its own language.

Liaise with the Y's Menettes A(S)D as appropriate, to add/update a section in the Manual specific to the Area.

EXTENSION (See Page 23)

Initiate the process of establishing new Y's Menettes Clubs in the Region.

Co-ordinate your efforts with relevant personnel - Y's Menettes, Y's Men, YMCA staff.

REGIONAL CONVENTIONS (See Page 32)

1. Liaise with Y's Men RD and Host Convention Committee to arrange:-
 - (a) Time/s and suitable venue for Y's Menettes session/s.
 - (b) Y's Menettes involvement in the total Convention program.
2. Arrange the program of the Y's Menettes session/s.
3. After Convention, distribute copies of the session/s minutes to all Clubs and relevant personnel.

FINANCE

Remind Clubs to complete all payments by the due dates:-

- Region/Area and International dues.
- Donations to Y's Menettes International Project.
- Donations to Y's Men's programs - Alex, Brotherhood, Time of Fast.

Keep an accurate record of expenses incurred and claim for reimbursement from Regional funds.

Ensure that any other Regional Y's Menettes personnel are reimbursed for their expenses - usually covered by Y's Menettes Regional dues. This should be an item in your Area's additional section of this Manual.

**Y'S MENETTES
AREA (SERVICE) DIRECTOR***

JOB DESCRIPTION

The Y's Menettes Area (Service) Director is the leader of the Y's Menettes Clubs in her Area and is responsible for promoting the conservation and extension of the Y's Menettes movement in the Area.

She may be elected by the Y's Menettes of the Area, or may be appointed by the Y's Men Area President.

The Y's Menettes A(S)D is a member of the Y'sdom Area team and should be prepared to be the representative/spokeswoman of the Y's Menettes of the Area.

She usually holds this office for one or two years.

(* In some Y'sdom Areas, the word SERVICE is not part of this Y's Menettes title).

COMMUNICATION

Main lines of communication for Y's Menettes A(S)D.

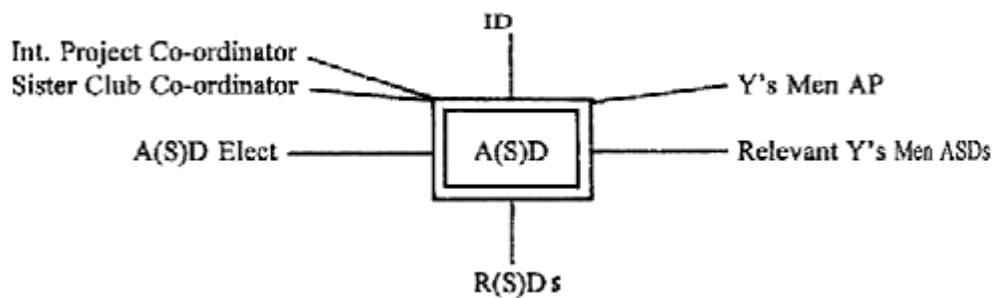

1. Maintain regular correspondence with ID, R(S)Ds, Y's Men AP and other personnel in the network as appropriate.
2. Forward to Y's Menettes R(S)Ds, all information and material received from Y's Menettes ID and International Coordinators for the Y's Menettes Project and Sister Club Program. (Perhaps a regular Newsletter).
3. Provide A(S)D Elect with copies of correspondence and information relevant to her coming A(S)D term.
4. Supply a Y's Menettes article for any Area Y'sdom publication.
5. Promote the support of the Y's Menettes International Project and the various programs of Y's Men International.

REPORTS

Receive annual report forms from ID and forward to R(S)Ds for distribution to Clubs. (In some Areas/Regions, the ID may have pre-arranged to send the forms directly to the R(S)Ds)

Compile A(S)D report by:-

- (a) Making photocopies of each R(S)D report form received (due May 1) and
- (b) Recording Y's Menettes Area events and information (See Page 45)

Send complete A(S)D report to Y's Menettes ID by due date (May 15), with copies to Y's Men AP and other relevant personnel. Be prepared to present this report at the Y's Men Area Annual Meeting.

RECORDS

Keep accurate and up-to-date files of all correspondence and important Y's Menettes material.
Hand over the files promptly to your successor.
Share suggestions for change/improvements.

MANUAL

Liaise with the Y's Menettes R(S)Ds to:-

- (a) Assist each Y's Menettes Club to have a copy of the Y's Menettes Manual in its own language.
- (b) Add/update a section in the Manual specific to the Area.

EXTENSION (See Page 23)

Initiate the process of establishing new Y's Menettes Clubs in the Area.
Co-ordinate your efforts with relevant personnel - Y's Menettes, Y's Men, YMCA staff.

AREA CONVENTIONS (See Page 32)

1. Liaise with Y's Men AP and Host Convention Committee to arrange:-
 - (a) Time/s and suitable venue for Y's Menettes session/s
 - (b) Y's Menettes involvement in the total Convention program.
2. Arrange the program of the Y's Menettes session/s.
3. After Convention, send copies of the session/s minutes to R(S)Ds (for distribution to Clubs) and to appropriate personnel.

FINANCE

Prompt R(S)Ds to remind Clubs of the due dates for payment of dues and Y's Menettes and Y's Men Project donations.

Keep an accurate record of expenses incurred and claim for reimbursement from Area funds.

Ensure that any other Area Y's Menettes personnel are reimbursed for their expenses - usually covered by Y's Menettes Area dues.

This should be an item in your Area's additional section of this manual.

Y'S MENETTES INTERNATIONAL DIRECTOR

JOB DESCRIPTION

The Y's Menettes International Director is the leader of the Y's Menettes Clubs of Y's Men International and is responsible for promoting the conservation, extension and service of the Y's Menettes movement.

She is appointed for a two year term by Y's Menettes leaders – the outgoing ID in consultation with two past IDs and the current A(S)Ds.

The Y's Menettes ID is a member of the Y'sdom International team and must be prepared to be the representative/spokeswoman of the Y's Menettes International movement.

COMMUNICATION

Main lines of communication for Y's Menettes ID.

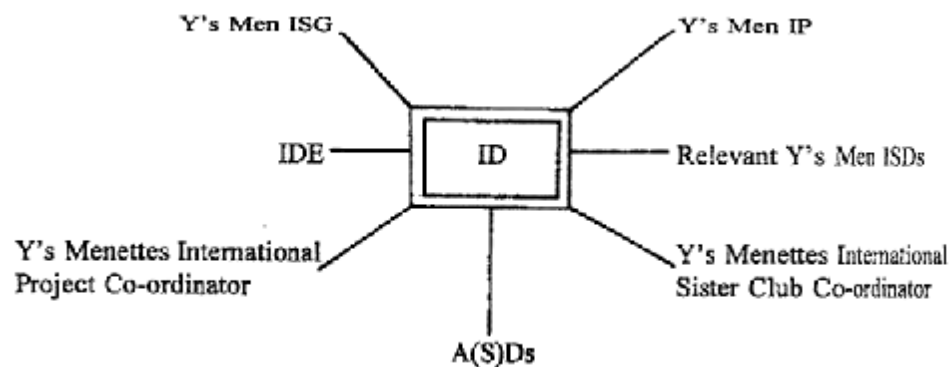

1. Maintain regular correspondence with the above network and other personnel as appropriate. Choose a theme for the term if desired.
2. Publish and distribute ID Newsletters, three or four per year to:-
 - (a) The above network
 - (b) Y's Menettes R(S)Ds and Clubs, via A(S)Ds.
 - (c) Y's Men APs, APEs, Historian, "Y's Men's World" Editor.
 These should contain information of value and interest to Y's Menettes e.g. International Project, Sister Club news, Clubs and events in Areas/Regions, Conventions, new Clubs, special achievements, Y's Men International projects.
3. Provide ID Elect with copies of correspondence and information relevant to her coming ID term.
4. Supply a Y's Menettes article for each edition of the Y's Men International publication "Y's Men's World". e.g. photos, progress report on current Y's Menettes Project.
5. Ensure continued supply and use of promotional materials e.g. Y's Menettes leaflets.

RECORDS

Keep Accurate and up-to-date files of all correspondence and important Y's Menettes material.
Hand over the files promptly to your successor.
Share any suggestions for change/improvement.

REPORTS

1. Produce annual Club and R(S)D report forms using the master copies in the files - use of coloured paper recommended for each type of form e.g. Club-pink, R(S)D-blue/yellow.
2. Distribute via A(S)Ds and R(S)Ds in Jan/Feb.
3. From A(S)D reports (due May 15) compile a Y's Menettes International Report consisting of:-
 - (a) Statistical table listing numbers of Clubs and members, Sister Clubs and contributions to Y's Menettes Project, Y's Men's programs, YMCA and community.
 - (b) Descriptive report of Y's Menettes events and achievements. (See Page 45)
4. Distribute copies of the report to Newsletter distribution recipients.
5. Provide Mid-year and Final reports for IHQ as requested.

MANUAL

Liaise with each Y's Menettes A(S)D to:-

- (a) Assist each Y's Menettes Club to have a copy of the Y's Menettes Manual in its own language.
- (b) Add/update a section in the Manual specific to the Area.

Regularly review/update the Manual found on the Y's Men International website.

Important changes/updates should be circulated to Clubs and personnel.

EXTENSION (See Page 23)

Encourage the process of establishing new Y's Menettes Clubs throughout Y'sdom, thus strengthening the Y's Menettes partnership role with Y's Men.

Encourage and assist, where appropriate, the relevant personnel - Y's Menettes, Y's Men, YMCA staff.

Y'S MENETTES INTERNATIONAL PROJECT

Liaise with the Project Co-ordinator to promote this important Y's Menettes program and share its progress.

At the conclusion of a two year Project, ensure that a final report is presented at the Y's Menettes session/s of the Y's Men International Convention, and circulated to all Clubs.

In the second year of the Project, organize the next one thus:-

1. Contact YMCA World Alliance HQ in Geneva for possible future projects (Sep/Oct).
2. Prepare a voting/information sheet on the suggested projects.
3. Via A(S)Ds and R(S)Ds, distribute these sheets to all Y's Menettes Clubs (Jan/Feb) requiring individual Club votes to be returned directly to ID (by May).
4. At the Y's Menettes session/s of the Y's Men International Convention (in July) announce:-
 - (a) the new project/s
 - (b) the appointment of the new Project Co-ordinator (previously arranged).

Y'S MENETTES SISTER CLUB PROGRAM

Liaise with the International Co-ordinator, to promote this program and to compile an annual report.

Appoint a new Sister Club Co-ordinator, prior to the completion of the outgoing Co-ordinator's term (usually two years).

INTERNATIONAL CONVENTIONS (See Page 32)

1. Liaise with Y's Men IP and Host Convention Committee to arrange:-
 - (a) Time/s and suitable venue for Y's Menettes session/s.
 - (b) Y's Menettes involvement in the total Convention program.
2. Arrange and conduct the Y's Menettes session/s. If the PID who has just completed her term is in attendance, she and the new ID should share the conducting of the Y's Menettes session/s. The host A(S)D may also assist.
3. After Convention, send copies of the session/s minutes to Clubs, R(S)Ds, A(S)Ds, personnel as appropriate.

Y'S MEN INTERNATIONAL COUNCIL MEETING (ICM)

The ICM is held annually each July. The Y's Menettes representative is entitled to speak at this meeting but not to vote. Y's Menettes are represented by the ID, also PID if she has just completed her term of office.

The ID from the previous year presents the Y's Menettes report, highlighting the main points and answering any questions. The incumbent ID presents plans for her term.

FINANCE

1. Encourage all Y's Menettes to make the required contribution to the Y's Menettes General Fund.
2. Consider the finance in the Y's Menettes General Fund and be prepared to allocate to additional uses in strict accordance with the surveys and voting conducted.
3. Keep an accurate record of expenses and claim for reimbursement at regular intervals from Y's Men IHQ, working within the budget provided by Y's Men IHQ.

Y'S MENETTES GENERAL FUND

This fund was set up in 1987 to cover the costs of the Y's Menettes ID to attend the Y's Men ICM – now covered by Y's Men International. It may now cover:-

1. **Expenses for ID, PID and Host A(S)D***
 - (a) The cost of travel to and accommodation at ICM each July for PID if her term has just finished but not if current ID is continuing for a second year.
 - (b) The cost for ID and PID (as above) at International Conventions for registration and accommodation.
 - (c) The cost for ID at Area Conventions connected to ICM every second year for registration and accommodation.
 - (d) The cost for Host A(S)D at International Conventions for registration and accommodation – if it is not covered by her own Area or Region.
2. Expenses of office for the International Sister Club Co-ordinator.
3. Other Matters: Expenses for:
 - (a) Printing, reprinting and translations of Manual and promotional leaflets.
 - (b) Extension matters – if there is money for it.
 - (c) Special tasks such as:
 - Special voting
 - Collecting information to make a record of Y's Menettes Clubs.
4. Y's Menettes International Project – if there is excess money in the Fund.

* The Fund will cover suitable, economical accommodation from the range offered by the Convention Committee.

If a Director chooses more expensive options she pays the extra costs herself.



Y's MENETTES CLUB REPORT FORM

CLUB PRESIDENT – Please complete this form, make a copy for your files and return to your Regional (Service) director BEFORE APRIL 15TH.

CLUB: _____ REGION _____ AREA _____

In what year did your Club receive its Charter? _____

MEETINGS Does your Club have meetings regularly? YES / NO
 How often? _____ When? _____ Where? _____

BULLETINS Does your Club publish a bulletin? YES / NO
 Title? _____ How often? _____

MEMBERSHIP Number of Club members _____
 Number of financial Y's Menettes at Large attached to Club _____
 Since last report, number of new members _____
 Since last report, number of members lost _____
 How many members are not married to Y's Men? _____
 Amount of annual Club dues per member (in local currency)
 (excluding Region/Area/International dues) _____

SISTER CLUBS Does your Club have a Sister Club/s? YES / NO
 Is the contact satisfactory? YES / NO
 Give name and country of each Sister Club: _____

CONVENTIONS During the past year, have any members attended Conventions?
 Regional - YES / NO Area - YES / NO International - YES / NO

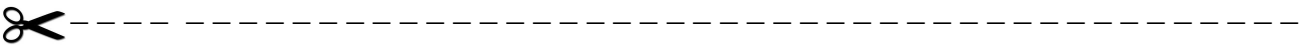

Please complete back of sheet

SERVICE List all service given by Club since last report.

	Practical assistance	Finance
Y'S MEN'S CLUB	_____	_____
YMCA	_____	_____
	_____	_____
COMMUNITY	_____	_____
	_____	_____
Y'S MENETTES INTERNATIONAL PROJECT		_____
ALEX FUND		_____
BROTHERHOOD FUND		_____
TIME OF FAST		_____

YEEP - Sponsoring _____ Hosting _____
 STEP - Sponsoring _____ Hosting _____

ANY OTHER _____

OUTSTANDING PROGRAMS AND ACTIVITIES (since last report)

Your Club's most successful fund-raising event: _____

Your Club's most interesting and enjoyable program: _____

ANY FURTHER CONCERNS, SUGGESTIONS, COMMENTS: _____

SIGNED _____
 PRESIDENT.



INCOMING OFFICERS

Please tear off this slip now. Complete it and send it to your R(S)D later on when your incoming officers are elected.

CLUB: _____ REGION _____ AREA _____

	Name	Address	Phone No.
PRESIDENT	_____	_____	_____
VICE PRESIDENT	_____	_____	_____
SECRETARY	_____	_____	_____
TREASURER	_____	_____	_____
BULLETIN EDITOR	_____	_____	_____



Y'S MENETTES REGIONAL (SERVICE) DIRECTOR'S REPORT FOR YEAR _____

R(S/D) _____ REGION _____

Please complete by listing each club's details on both sides and mail this form to your A(S/D) by May 1 st

MEMBERSHIP and CLUB MATTERS

Club	Charter Year	Number of Members	Y's Menettes at Large	New Members	Members	Lost Members	Not married to Y's Men	Amount of club dues Per member	Bulletins – Title	Sister Club/s – Name/s Satisfactory Contact?	Most Successful Fund-raising Event	Most interesting and enjoyable program
Total												



Y'S MENETTES REGIONAL (SERVICE) DIRECTOR'S REPORT FOR YEAR _____

R(S)D _____ REGION _____

Please complete by listing each club's details on both sides and mail this form to your A(S)D by May 1 st

SERVICE and CONTRIBUTIONS

Club	Y's Men Assistance Financial/Practical	YMCA Assistance Financial/Practical	Community Assistance Financial/Practical	Alexander Fund	Brotherhood Fund	Time of Fast	YEEP	Y's Menette International Project	Other
	\$	\$	\$	\$	\$	\$		\$	\$
Total	\$	\$	\$	\$	\$	\$		\$	\$

Y'S MENETTES DIRECTOR REPORTS

When compiling her annual report, each Y's Menettes Director (ID, A(S)D and R(S)D) would give a more complete picture by presenting her report in two parts:-

1. Statistical Form (See Page 43)
2. Descriptive Report under such headings as:-
 - (a) Membership - changes due to newly chartered Clubs or Clubs lost.
 - (b) Conventions, camps and/or special gatherings of Y's Menettes.
 - (c) Communication - e.g. Newsletters, articles written for Y's Men and YMCA publications, Club Bulletins received.
 - (d) Service - information not included on the statistical form.
 - (e) Summary of highlights/activities/operation of the Y's Menettes of:-
 - each Area (in ID report).
 - each Region (in A(S)D report).
 - each District/Club (in R(S)D report).
 - (f) Finance - dues paid and their use.
 - (g) Y's Menettes materials - badges/pins, stationery, Manual.
 - (h) Sister Club Program.
 - (i) Y's Menettes International Project.
 - (j) Events and occasions attended by Y's Menettes Director.
 - (k) Awards.
 - (l) Acknowledgements - any special personnel.

 CHARTER APPLICATION FORM FOR CLUB (Y's Menettes or Y Service Club – Women) <small>(Please type or print in English)</small>	
Name of Area & Region	
Name of Club	
Sponsoring Club	
Date of Inauguration	
Contact Information for Club President <small>(Name, postal address, telephone, email address)</small>	
Contact Information for Club Secretary <small>(Name, postal address, telephone, email address)</small>	
Charter Certificate to be sent to:	
List of Club Members	Please attach a list of members to this form
Brief History of this Club <small>(attach sheet, if needed)</small>	
Club Projects/Activities	
Planned Presentation Date for Charter Certificate <small>(if known)</small>	
Signature of Club President	Signature of Club Secretary
Date:	Date:

Please send completed form to International Director for Y's Menettes

Y'S MENETTES INTERNATIONAL PROJECTS

TERM	PROJECT	GOAL \$US	PAID \$US
1982 – 84	Sri Lanka – 50 Underprivileged children.	6,000	9,000
1984 – 86	Gambia – Car for YMCA staff, village project.	6,000	23000
1986 – 88	Guatemala – Vehicle to help village projects.	8,000	8,000
	East Jordan – Palestinian refugee girls to summer camp.	11,500	11,500
1988 – 90	Curacao – Two classrooms for youth development.	12,000	Cancelled
1990 – 92	Amazonic Trapeze – Bringing YMCA to 3 villages.	15,000	20,000
	Sri Lanka – Methodist home for elderly.	10,000	10,000
1992 – 94	Uganda – Youth technical training centre.	12,000	12,000
	Bangladesh – Research development, extension.	10,000	10,000
1994 – 96	South Africa – Street children's program.	21,710	21,710
	Bangladesh – Research development, extension continued.	10,000	10,000
1996 – 98	The Gambia – Women's development program.	21,000	21,000
	Costa Rica – Gender in development.	10,000	10,000
	India – Empowerment of women seminar.	5,000	5,000
1998 – 2000	Senegal – Adolescent reproductive health.	15,000	15,000
	Bulgaria – Community development centre.	10,400	10,400
2000 – 02	Indonesia – Women's community participation.	7,500	7,500
	Philippines – Women's empowerment and development.	6,000	6,000
2002 – 04	Bolivia – Adolescent project of life.	15,000	15,000
2004 – 05	India – Women's employment opportunities.	4,000	4,000
2005 – 10	Russia – Children draw anti AIDS posters.	2,700	2,700
	Bolivia – HIV/AIDS information and prevention.	26,796	26,796
	Costa Rica – HIV/AIDS awareness and training.	15,000	15,000
	Uganda – HIV/AIDS awareness and prevention.	15,780	15,780
	Canada – YMCA HIV/AIDS program.	3,300	3,300
2010 – 12	Nigeria – Quality water for YMCA camp.	30,000	18,000 Terminated
2012 – 14	India – Centre for HIV/AIDS awareness.	CHF 23,580	CHF 23,330
2014 – 16	India – Rural project for widows and poor women.	CHF 22,008	
	Brazil – Forming skills through projects pedagogy.	CHF 16,830	