

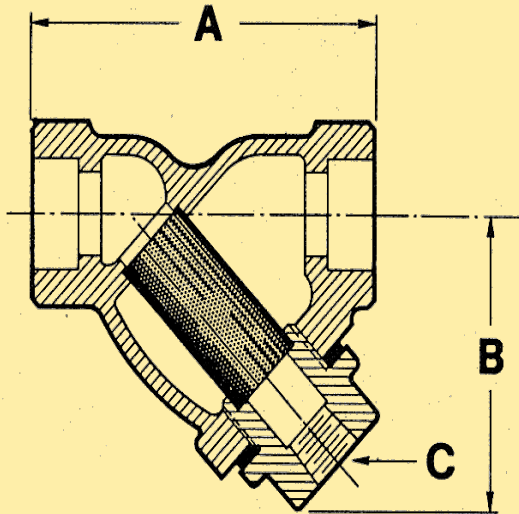

## CAST ALUMINUM BRONZE SOLDER END "Y" STRAINER

MODEL: AB5-150

WORKING PRESSURES: NON SHOCK	
AB5-150	400 psi @ 100° F



### SERVICE RECOMMENDATIONS

The AB5-150 is recommended for seawater/marine use because of its anti corrosive properties. The copper content ensures that marine life cannot adhere to the strainer. This material is also perfect for potable water and meets the Reduction of Lead in Drinking Water (RLDWA) Act (which mandates that the lead content in wetted surfaces is less than 0.25% by weight)

### SCREENS

The standard screens are 20 mesh in 304SS for water service. 2 1/2" and 3" size come standard with 1/16" perf 304SS. Fabrotech can supply screens in Monel 400, in various perforation sizes and mesh linings up to 400 mesh.

### CONSTRUCTION

Manufactured from Silicone Bronze, B176 C87800, which is an excellent choice for sea water and other corrosive applications. Silicone Bronze is also commonly used on potable water applications because it meets lead free requirements.

### BLOWOFF OUTLETS:

Tapped NPT, sizes specified below ("C" dimension). Not normally furnished plugged.

**MEETS LEAD FREE REQUIREMENTS**

DIMENSIONS & WEIGHTS APPROXIMATE  
(Apply for certified drawings)

INDIVIDUALLY HYDROSTATICALLY TESTED

SIZE	in.	1/4"-1/2"	3/4"	1"	1 1/4"	1 1/2"	2"	2 1/2"	3"
	mm.	8, 10, 15	20	25	32	40	50	65	80
A	in.	3.00	3.68	4.75	5.43	5.937	7.43	9.75	10.37
B	in.	2.25	2.56	2.75	3.625	3.875	5.125	6.00	6.75
C	(NPT)	.25	.375	.375	.750	.75	1	1.25	1.50
WT (lb.)		.75	1.375	2.13	3.13	4.5	7	12.50	18.00

## FABROTECH INDUSTRIES, INC.

2089 NINTH AVENUE, RONKONKOMA, NEW YORK 11779

TEL: (631) 467-2040 FAX: (631) 467-2196 e-mail: info@fabrotech.com

www.fabrotech.com