

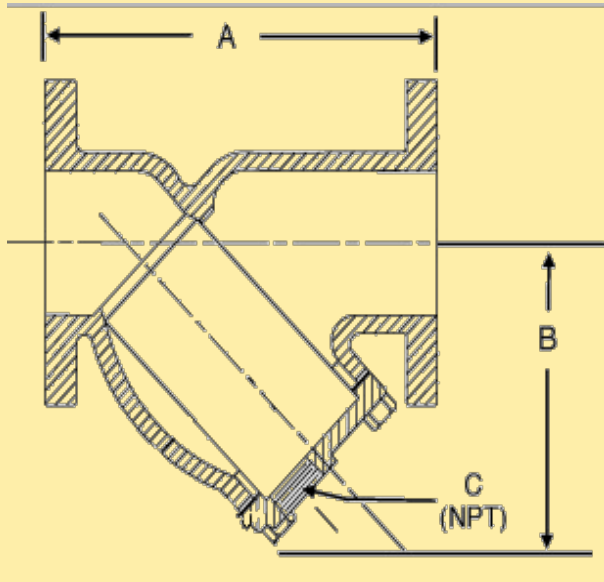

CLASS 150 CAST ALUMINUM BRONZE FLANGED "Y" STRAINER

MODEL AB8-150

| WORKING PRESSURES: NON SHOCK | |
|------------------------------|------------------|
| STEAM: | 150 psi @ 405° F |
| WOG: | 225 psi @ 150° F |



SERVICE RECOMMENDATIONS

The AB8-150 is the preferred choice for seawater/marine use because of its anti corrosive properties. The copper content ensures that marine life cannot adhere to the strainer. This material is also perfect for potable water and meets the Reduction of Lead in Drinking Water (RLDWA) Act (which mandates that the lead content in wetted surfaces is less than 0.25% by weight)

SCREENS

The standard screens are 1/16" perf 304SS up to 4" size, and 1/8" perf above that, for water service. Fabrotech can supply screens in Monel 400, in various perforation sizes and mesh linings up to 400 mesh.

CONSTRUCTION

Manufactured from Cast Aluminum bronze (ASTM B148 Gr. 9D), which is the preferred choice for sea water and other corrosive uses. Aluminum Bronze is also used on potable water applications and it meets lead free requirements.

BLOWOFF OUTLETS:

Tapped NPT, sizes specified below ("C" dimension). Not normally furnished plugged.

Pressure gauge taps, plugged, are standard

INDIVIDUALLY HYDROSTATICALLY TESTED

MEETS LEAD FREE REQUIREMENTS

DIMENSIONS & WEIGHTS APPROXIMATE
(Apply for certified drawings)

| SIZE | in. | 2" | 2 1/2" | 3" | 4" | 6" | 8" | 10" |
|----------|-------|-------|--------|---------|--------|---------|--------|--------|
| | mm. | 50 | 65 | 80 | 100 | 150 | 200 | 250 |
| A | in. | 7 3/4 | 9 3/4 | 10 1/16 | 12 1/8 | 18 5/16 | 21 3/8 | 26 |
| B | in. | 5 1/4 | 6 1/2 | 7 | 8 1/4 | 13 1/2 | 15 1/2 | 18 1/2 |
| C | (NPT) | 1/2 | 1 | 1 | 1 1/2 | 2 | 2 | 2 |
| WT (lb.) | | 22 | 34 | 38 | 64 | 132 | 240 | 315 |

FABROTECH INDUSTRIES, INC.

2089 NINTH AVENUE, RONKONKOMA, NEW YORK 11779

TEL: (631) 467-2040 FAX: (631) 467-2196 e-mail: info@fabrotech.com

www.fabrotech.com