

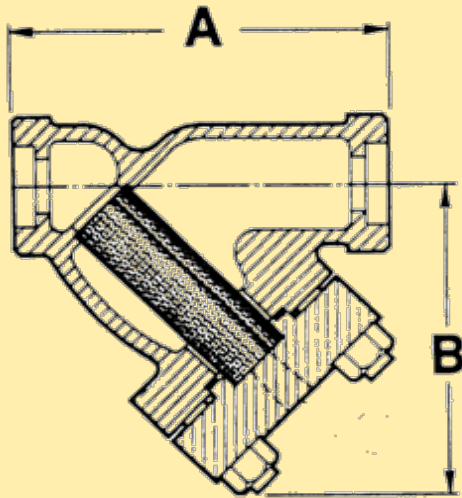

2500 LB. CAST CARBON STEEL THREADED & SOCKET WELD "Y" STRAINERS

MODELS: C9-2500 & C6-2500



DIMENSIONS & WEIGHTS APPROXIMATE
(Apply for certified drawings)

PRESSURE-TEMPERATURE RATINGS
6170 psi @100° F
2500 psi @838° F

SERVICE RECOMMENDATIONS

These strainers are built for long term use under demanding conditions. Because they have been designed to withstand high temperatures and pressures, they are recommended to use for protection to pumps, valves, compressors, etc.

FEATURES

The C9-2500 & C6-2500 have machined seats in the body and cap, which allow for proper screen alignment & seating. All Sizes are normally furnished blind (no blowoff connection in the bolted cover, but a socket weld or NPT blowoff is available & should be specified when ordering.

SCREENS

Stainless steel screens (grade 304) are normally furnished in the following perforations:

- Steam Service:** .045"
- Liquid Service:** .062"

Other materials, such as Monel, Hastelloy C, & Alloy-20 are available. Other perforation sizes and/or mesh lining is also available.

CONSTRUCTION

The body, which is cast from Carbon Steel (ASTM A216, Gr. WCB). Also available in Chrome Moly (ASTM A217, Grades WC6 & WC9), and Carbon Moly (ASTM A217, Grade LCB) Furnished with RTJ gaskets for high pressure sealing. The socket weld bore is in accordance with ANSI B16.11.

INDIVIDUALLY HYDROSTATICALLY TESTED

SIZE in.	1/2"	3/4"	1"	1 1/4"	1 1/2"	2"
mm	15	20	25	32	40	50
A	9.25	9.25"	9.25	12.0	12.0	12.0
B	8.55	8.55"	8.25	9.0	9.0	9.0
WT (lb.)	35	35	35	75	75	75
Cv	9	9	9	30	30	42

FABROTECH INDUSTRIES, INC.

2089 NINTH AVENUE, RONKONKOMA, NEW YORK 11779

TEL: (631) 467-2040 FAX: (631) 467-2196 e-mail: info@fabrotech.com
www.fabrotech.com