

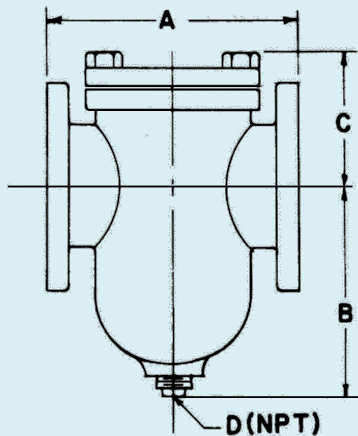

150# & 300# CARBON STEEL FLANGED SIMPLEX BASKET STRAINER

MODELS: F85CS & F86CS



DIMENSIONS & WEIGHTS ARE APPROXIMATE
(Apply for certified drawings)

PRESSURE-TEMPERATURE RATINGS		
STEAM:	F85CS	150 psi @ 565° F
	F86CS	300 psi @ 838° F
WOG:	F85CS	285 psi @ 100° F
	F86CS	740 psi @ 100° F

SERVICE RECOMMENDATIONS

These strainers are designed for long term service under demanding conditions created by high temperatures and pressures. These models are designed for medium or coarse straining. For finer straining, we suggest our model 125F-CS/126F-CS

CONSTRUCTION

Extremely rugged bodies in cast carbon steel (ASTM A216 Grade WCB). Castings also available in Chrome-Moly (ATSM A217, Grades WC6 & WC9). All sizes feature a bolted cover for easy basket removal. Both models can be ordered with taps for the installation of pressure gauges (not supplied). All sizes feature tapped and plugged NPT drain connections.

BASKETS

All sizes feature slant baskets which allow for a straight through flow and results in extremely low pressure drop.

For steam service, we normally supply .045 perf up through 10" pipe size. Above 10", we furnish 1/16" perf.

For liquid service, we normally furnish 1/16" perf for sizes up to 3", and 1/8" perf for 4" and up.

Baskets are also available in a variety of other perforated material such as Monel, Alloy 20, and Hastelloy. For mesh lining, we recommend 5/32" perforated material lined with an appropriate wire mesh.

INDIVIDUALLY HYDROSTATICALLY TESTED

Size: in	2"	2 1/2"	3"	4"	5"	6"	8"	10"	12"
mm	50	65	80	100	125	150	200	250	300
A: F85-CS	8 1/2	8	8 3/4	11 3/16	12 1/4	13 7/8	17 3/8	22	25
A: F86-CS	8 1/2	8 11/16	9 9/16	11 3/4	13 1/8	14 3/4	18 1/8	22 7/8	25 3/8
B: F85-CS	5 7/8	5 7/16	5 1/4	7 7/8	10 1/4	12 1/2	15 1/8	16 1/2	18 3/4
B: F86-CS	6 1/8	6 1/4	8 1/4	8 5/8	11	12 3/4	15 1/2	17 1/8	25
C: F85-CS	5	4 3/4	5 1/2	6 1/8	5 5/8	6 3/4	8 7/8	10 3/4	13 3/4
C: F86-CS	4 7/8	5 1/2	6 1/16	5 5/16	6	6 3/8	8 1/16	9 3/4	11 3/4
D (NPT)	1/2	3/4	3/4	1	1	1 1/4	1 1/2	1 1/2	2
Wt: F85-CS	27	33	38	68	108	148	234	365	490
Wt: F86-CS	34	40	55	86	121	196	292	460	670
Cv	45	90	140	290	500	800	1600	2800	3700

16" - 20" DIMENSIONS AVAIL. ON REQ.

FABROTECH INDUSTRIES, INC.

2089 NINTH AVENUE, RONKONKOMA, NEW YORK 11779

TEL: (631) 467-2040 FAX: (631) 467-2196 e-mail: info@fabrotech.com

www.fabrotech.com