

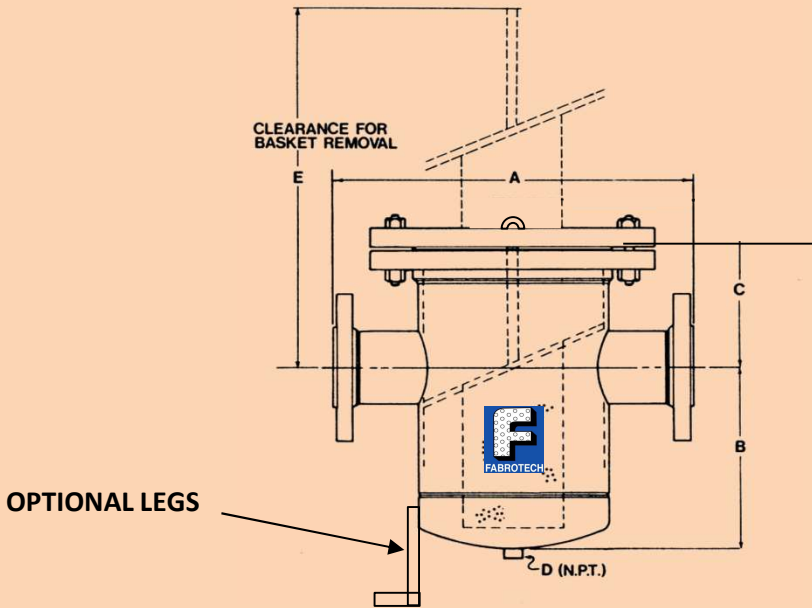

FABRICATED SIMPLEX with BOLTED BLIND

150# ANSI/300# ANSI (HIGHER CLASSES AVAILABLE)

MODEL H-150/H-300: BUTTWELD



MODEL HF-150/HF-300: FLANGED

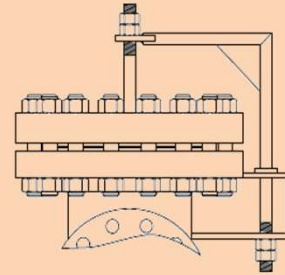

OPTIONAL LIFTING DAVIT
"HD" or HFD"

FABRICATED PER ASME B31.3. OTHER CODES (B31.1/31.4/31.8) ARE ALSO AVAILABLE

**ASME CODE STAMP AVAILABLE
600#, 900#, 1500# or 2500# ANSI AVAILABLE
ALL UNITS HYDROTESTED PER ASME B16.5
MATERIAL TEST REPORTS AS OUR STANDARD**

DIMENSIONS (inches)**

APPROX. NET WEIGHT (lbs.)

NOM SIZE	A		B	C		D (npt)	E	CLASS 150		CLASS 300	
	Class 150	Class 300		Class 150	Class 300			Cover	Unit	Cover	Unit
	4	16		16	14			10 1/2	11 1/2	1	21
5	16	17 1/2	15	10 1/2	11 1/2	1	22	45	153	81	237
6	20	21	17	12	12 3/4	1	24	70	203	127	328
8	22	23	21	14	14	1 1/2	28	110	281	184	407
10	32	33	25	15	15	1 1/2	33	140	450	248	710
12	35	36	28	17	17	1 1/2	39	177	644	315	1024
14	37	38	33	19	19	2	45	220	951	392	1397
16	42	43	36	20	21	2	49	276	1409	494	2011
18	42	43	39	22	22	2	53	425	1486	760	2127
20	43	44 1/2	44	24	24	2	59	425	1553	760	2231
24	48	49 3/4	58	28	30	2	78	681	2291	1403	3497
30	62	66	60	32	34	2	110	1676	5770	2436	6185

SINCE THESE STRAINERS ARE CUSTOM MADE TO ORDER, DIMENSIONS CAN BE ALTERED TO MEET YOUR REQUIREMENTS. ALL FABRICATION IS DONE HERE AT OUR FACILITY ON LONG ISLAND, NY.

FABROTECH INDUSTRIES, INC.

2089 NINTH AVENUE, RONKONKOMA, NEW YORK 11779

TEL: (631) 467-2040 FAX: (631) 467-2196 e-mail: info@fabrotech.com

www.fabrotech.com