



FABRICATED SIMPLEX with HINGED COVER

150# ANSI/300# ANSI (HIGHER CLASSES AVAILABLE)

MODEL HQ: BUTTWELD

MODEL HFQ: FLANGED

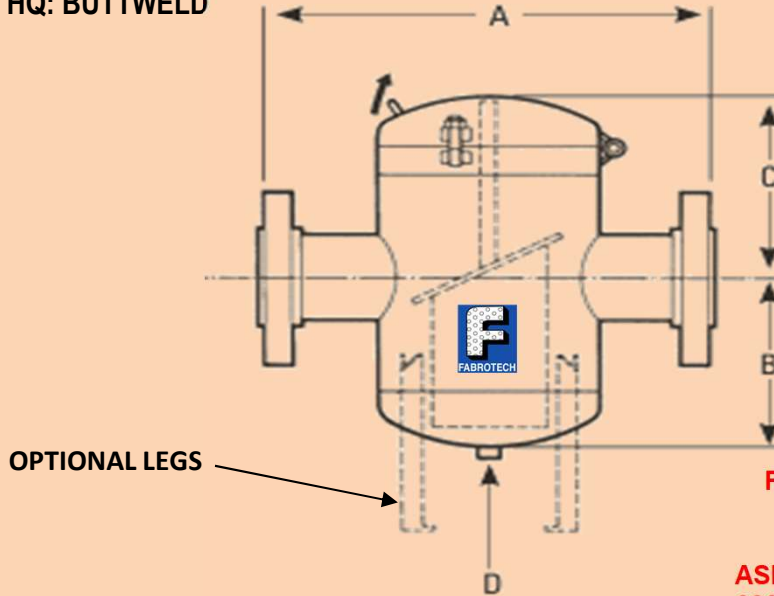

FABRICATED PER ASME B31.3. OTHER CODES (B31.1/31.4/31.8) ARE ALSO AVAILABLE

ASME CODE STAMP AVAILABLE
600#, 900#, 1500# or 2500# ANSI AVAILABLE
ALL UNITS HYDROTESTED PER ASME B16.5
MATERIAL TEST REPORTS AS OUR STANDARD

DIMENSIONS (inches)**

NET WEIGHT (lbs.)

NOM SIZE	A		B	C		D (npt)	E	CLASS 150		CLASS 300	
	Class 150	Class 300		Class 150	Class 300			Cover*	Unit	Cover*	Unit
	4	16		16	14			10 3/4	10 3/4	1	21
5	16	17 1/2	15	11 1/4	11 1/4	1	22	9	128	9	176
6	20	21	17	12	12	1	24	12	168	12	236
8	22	23	21	13 1/4	13 1/4	1 1/2	28	15	226	15	278
10	32	33	25	14 1/2	14 1/2	1 1/2	33	30	360	30	483
12	35	36	28	15 3/4	15 3/4	1 1/2	39	37	535	37	734
14	37	38	33	16 1/2	16 1/2	2	45	46	804	46	1030
16	42	43	36	17 3/4	17 3/4	2	49	68	1188	68	1437
18	42	43	39	19	19	2	53	68	1255	68	1553
20	43	44 1/2	44	25	26 1/2	2	59	71	1322	71	1656
24	48	49 3/4	54	28	30	2	78	88	1860	88	2344

SINCE THESE STRAINERS ARE CUSTOM MADE TO ORDER, DIMENSIONS CAN BE ALTERED TO MEET YOUR REQUIREMENTS. ALL FABRICATION IS DONE HERE AT OUR FACILITY ON LONG ISLAND, NY.

FABROTECH INDUSTRIES, INC.

2089 NINTH AVENUE, RONKONKOMA, NEW YORK 11779

TEL: (631) 467-2040 FAX: (631) 467-2196 e-mail: info@fabrotech.com

www.fabrotech.com