

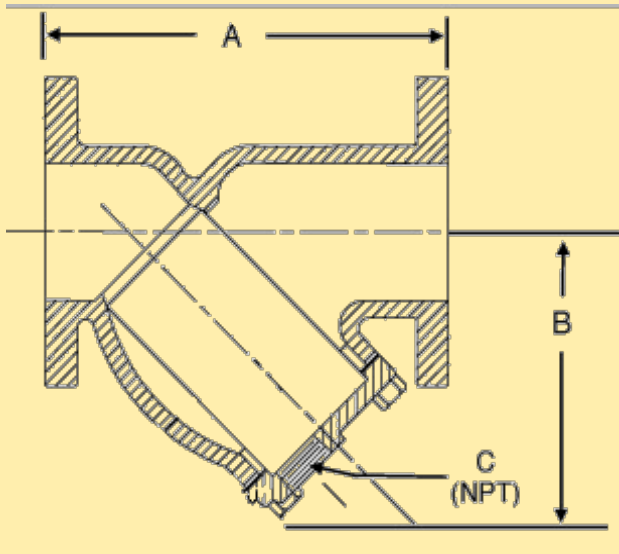

125 LB. CAST IRON FLANGED "Y" STRAINER

MODEL: I8-125



PRESSURE-TEMPERATURE RATINGS

STEAM: 3/4" to 12"	125 psi @ 450° F
STEAM: 14" to 18"	100 psi @ 350° F
WOG: 3/4" to 12"	200 psi @ 150° F
WOG: 14" to 18"	150 psi @ 150° F

SERVICE RECOMMENDATIONS

The I8-125 is designed to provide economical & dependable protection to mechanical equipment. Self cleaning is easily accomplished by opening the plug or valve connected to the blowoff outlet (not supplied). The cast iron body will provide years of dependable service in non corrosive applications.

FEATURES

All sizes feature a bolted cover. The cover has a recessed seat which assures correct screen fit. There are bosses located at the inlet and outlet flanges for the installation of gauges (not supplied).

SCREENS

Heavy gauge 304 stainless steel screens are normally furnished in the following perforations:

SERVICE:	3/4" - 4"	5" to 18"
Steam:	.045"	.062"
Liquid :	.062"	1/8"

Other materials, such as Monel, Hastelloy C, & Alloy-20 are available. Other perforation sizes and/or mesh lining is also available.

CONSTRUCTION

The body and cover are constructed from Cast Iron (ASTM A126 B), and the flat gasket is fiber. The blowoff outlets are tapped NPT and are not normally supplied with plugs.

DIMENSIONS & WEIGHTS APPROXIMATE
(Apply for certified drawings)

INDIVIDUALLY HYDROSTATICALLY TESTED

Size in.	3/4"	1"	1 1/4"	1 1/2"	2"	2 1/2"	3"	4"	5"	6"	8"	10"	12"	14"	16"	18"
mm	20	25	32	40	50	65	80	100	125	150	200	250	300	350	400	450
A	7 3/8	7 3/8	7 1/2	7 1/2	7 7/8	10	10 1/8	12 1/8	15 5/8	18 1/2	21 5/8	25 3/4	29 7/8	37 1/4	42 3/8	43 1/8
B	3 3/4	3 7/8	4 3/4	4 3/4	5 1/4	6 1/2	7	8 1/4	11 1/4	13 1/2	15 1/2	18 1/2	21 3/4	29	33	31
C (NPT)	1/2	1/2	1/2	1/2	1/2	1	1	1 1/2	2	2	2	2	2	2	2	2
WT (lb)	10	10	13	13	18	28	34	60	95	133	247	370	579	863	1100	2272

Also available in sizes 20" & 24"

FABROTECH INDUSTRIES, INC.

2089 NINTH AVENUE, RONKONKOMA, NEW YORK 11779

TEL: (631) 467-2040 FAX: (631) 467-2196 e-mail: info@fabrotech.com

www.fabrotech.com