



CLASS 1500 & 2500 CAST 316SS FLANGED & BUTTWELD "Y" STRAINERS

MODELS:

S8-1500 & S8-2500 (FLANGED)
S7-1500 & S7-2500 (BUTTWELD)

PRESSURE-TEMPERATURE RATINGS (per ANSI B16.5)		
STEAM:	S8-1500/S7-1500	1500 psi @ 740° F
	S8-2500/S7-2500	2500 psi @ 740° F
WOG:	S8-1500/S7-1500	3600 psi @ 100° F
	S8-2500/S7-2500	6000 psi @ 100° F

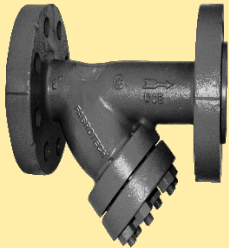

S8-1500/S8-2500



S7-1500/S7-2500

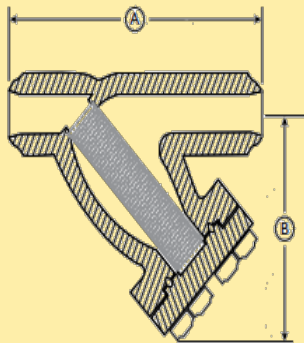
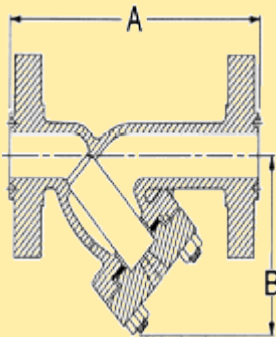

SERVICE RECOMMENDATIONS

These strainers are designed for dependable service under demanding conditions created by high temperatures and very high pressures or very low (cryogenic service). Recommended for use in corrosive applications or chemical/food industries.

FEATURES

Bodies are Cast 316 SS (ASTM A351 Gr. CF8m) with bolted covers machined to receive the screen. The stainless steel spiral wound cover gaskets are designed for high temperature service. Studs are A193-B7. Nuts are A194-2H heavy hex. Covers are furnished without a blowoff tapping. Ring Type Joint ends (RTJ) are available.

SCREENS

304 stainless steel screens are normally furnished in the following perforations:

Steam Service:	To 4" - .033" perf.	5" and up - .045" perf
Liquid Service:	To 4" - .062" perf.	5" and up - 1/8" perf

CONSTRUCTION

Extremely rugged bodies available from stock in 316SS ASTM A351 Gr. CF8M. The cover is also cast 316SS. Flanged models have end flanges faced and drilled in accordance with ANSI B16.5. Ring type joints are available. 1500# buttweld ends have a schedule of 160 & 2500# have BW ends machined to XXS pipe in accordance with ANSI B16.25 Fig. 2(B)

DIMENSIONS/WEIGHTS APPROX. (Apply for certified drawings)

INDIVIDUALLY HYDROSTATICALLY TESTED

SIZE	in.	2"	2 1/2"	3"	4"	6"	8"
	mm	50	65	80	100	150	200
A	S8-1500	16.50	18.00	18.00	22.50	32.50	36.00
	S8-2500	16.25	-	22.00	29.125	36.75	45.00
	S7-1500	12.00	18.125	18.125	18.125	23.75	30.125
	S7-2500	12.00	-	18.00	24.00	27.00	33.00
B	S8-1500	9.25	12.00	12.00	15.375	20.00	26.68
	S8-2500	10.50	-	13.00	17.00	21.75	29.00
	S7-1500	9.25	12.00	12.00	15.375	20.00	22.75
	S7-2500	11.00	-	15.00	17.00	21.75	29.00
WT.	S8-1500	91	175	175	316	766	1575
	S8-2500	275	-	350	550	787	990
	S7-1500	46	100	100	194	460	876
	S7-2500	64	-	169	307	688	1465
Cv		60	140	140	180	450	650

FABROTECH INDUSTRIES, INC.

2089 NINTH AVENUE, RONKONKOMA, NEW YORK 11779

TEL: (631) 467-2040 FAX: (631) 467-2196 e-mail: info@fabrotech.com

www.fabrotech.com