

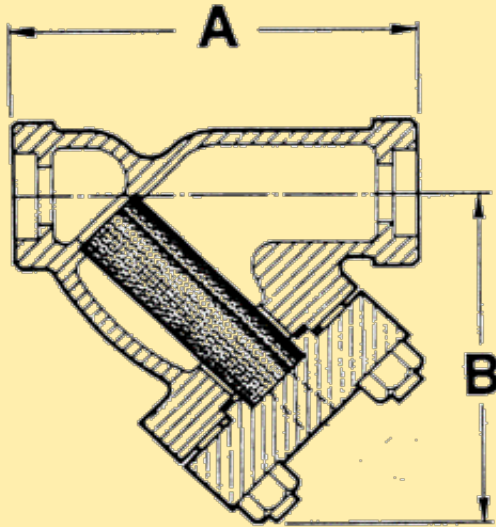

1500 LB. CAST 316SS THREADED & SOCKET WELD "Y" STRAINERS

MODELS: S9-1500 & S6-1500



DIMENSIONS & WEIGHTS APPROXIMATE

(Apply for certified drawings)

PRESSURE-TEMPERATURE RATINGS

3660 psi @ 100°F

SERVICE RECOMMENDATIONS

These strainers are built for long term use under demanding conditions. Because they have been designed to withstand high temperatures and pressures, they are recommended to use for protection to pumps, valves, compressors, etc.

FEATURES

The S9-1500 & S6-1500 have machined seats in the body and cap, which allow for proper screen alignment & seating. All Sizes are furnished blind (no blowoff connection) because of the high pressure.

SCREENS

Stainless steel screens (grade 304) are normally furnished in the following perforations:

Steam Service: .045"
Liquid Service: .062"

Other materials, such as Monel, Hastelloy C, & Alloy-20 are available. Other perforation sizes and/or mesh lining is also available.

CONSTRUCTION

The body, which is cast from 316SS (ASTM A351, Gr. CF8M), is available from stock. Also available in Hastelloy C, Alloy 20 or Monel. Furnished with stainless steel spiral wound gaskets with graphite filler as standard. The socket weld bore is in accordance with ANSI B16.11.

INDIVIDUALLY HYDROSTATICALLY TESTED

SIZE in.	1/2"	3/4"	1"	1 1/4"	1 1/2"	2"
mm	15	20	25	32	40	50
A	3.94	4.25	6.00	8 3/8	8 3/8	10.50
B	3.00	3.75	5.75	5 1/2	5 1/2	9 1/4
WT (lb.)	4.5	11	16	32	34	60
Cv	6	11	16	32	34	60

FABROTECH INDUSTRIES, INC.

2089 NINTH AVENUE, RONKONKOMA, NEW YORK 11779

TEL: (631) 467-2040 FAX: (631) 467-2196 e-mail: info@fabrotech.com

www.fabrotech.com