



FABROTECH INDUSTRIES, INC.

INSTALLATION & MAINTENANCE INSTRUCTIONS

FOR TEE TYPE STRAINERS

For maximum efficiency, determine length of time it takes for baskets to become approximately 1/3 clogged. At that time, release pressure from the vent connection in the cover and remove top cover and clean the basket. Replace basket in strainer in original position and tighten cover. Replace gasket if necessary. Spare basket will facilitate shorter "shut down time". Pressure gauges installed before and after strainer in the line will indicate pressure loss due to clogging, and may be used as a guide to determine when cleaning is required.

SPARE PARTS

To order replacement baskets or gaskets, which are the only items normally required, specify the following:

- a) Size and figure number of Tee Strainer.
- b) Specify service, i.e.: water, steam, air or oil.

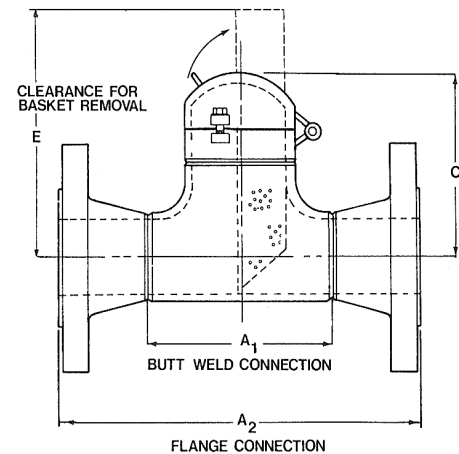
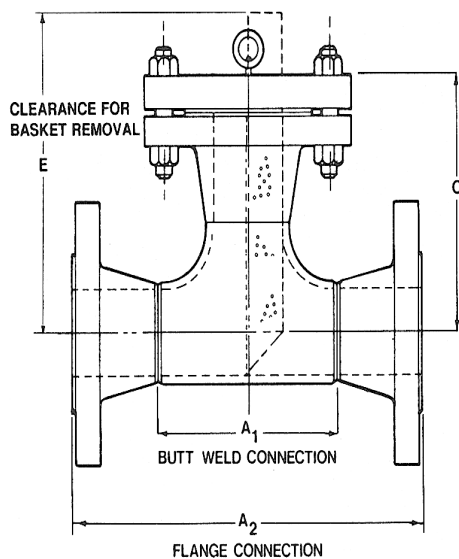

2089 NINTH AVENUE • RONKONKOMA, NY 11779
PHONE (631) 467-2040 • FAX (631) 467-2196