



THE CHLORINE INSTITUTE

# Pamphlet 6

*Piping Systems for Dry  
Chlorine*

*Edition 16*



March 2013

---





# Table of Contents

<b>1. INTRODUCTION</b> .....	<b>1</b>
1.1 SCOPE .....	1
1.2 CHLORINE INSTITUTE STEWARDSHIP PROGRAM.....	1
1.3 DEFINITIONS AND ACRONYMS .....	2
1.4 DISCLAIMER.....	4
1.5 APPROVAL.....	4
1.6 REVISIONS .....	4
1.7 REPRODUCTION.....	4
<b>2. GENERAL</b> .....	<b>5</b>
2.1 PRECAUTIONS .....	5
2.2 CERTIFICATION .....	6
2.3 MATERIALS.....	6
2.4 SELECTION.....	7
2.5 WELDING.....	8
<b>3. PIPE AND PIPING COMPONENTS</b> .....	<b>8</b>
<b>4. VALVES</b> .....	<b>17</b>
4.1 TYPES OF VALVES.....	17
4.2 GENERAL VALVE SELECTION CRITERIA.....	21
4.3 VALVE SELECTION TABLES .....	22
4.4 VALVE MATERIALS TABLE .....	25
4.5 VALVE PREPARATION - IDENTIFICATION REQUIREMENTS.....	28
<b>5. OTHER COMPONENTS</b> .....	<b>29</b>
5.1 RUPTURE DISCS .....	29
5.2 PRESSURE RELIEF VALVES.....	30
5.3 LIQUID KNOCKOUT POTS .....	31
5.4 TRANSPORTATION VALVES ON STATIONARY EQUIPMENT .....	32
5.5 LIQUID EXPANSION CHAMBERS .....	32
5.6 CHECK VALVES.....	33
5.7 EXPANSION JOINTS .....	33
5.8 HOSES .....	34
<b>6. INSTRUMENTATION</b> .....	<b>34</b>
<b>7. NONFERROUS METAL TUBING SYSTEMS</b> .....	<b>34</b>
<b>8. TRANSPORTATION CONTAINER CONNECTIONS</b> .....	<b>35</b>
<b>9. PLASTIC MATERIALS OF CONSTRUCTION</b> .....	<b>36</b>
<b>10. PIPING LAYOUT DESIGN CONSIDERATIONS</b> .....	<b>39</b>
10.1 CLEARANCES.....	40
10.2 SUPPORTS .....	40
10.3 ROUTING.....	40
10.4 VALVING.....	40
10.5 HYDRAULIC THERMAL EXPANSION DESIGN CONSIDERATIONS .....	41
10.6 DESIGN CONSIDERATIONS TO PREVENT CONDENSATION.....	41

10.7	VAPORIZATION.....	41
10.8	INSULATION .....	41
10.9	PAINTING.....	41
<b>11.</b>	<b>PREPARATION FOR USE.....</b>	<b>41</b>
11.1	CLEANING .....	41
11.2	PRESSURE TESTING.....	43
11.3	DRYING .....	44
11.4	TESTING FOR LEAKS .....	45
<b>12.</b>	<b>ROUTINE AND PERIODIC INSPECTION AND MAINTENANCE .....</b>	<b>46</b>
12.1	ROUTINE MAINTENANCE .....	46
12.2	PREVENTATIVE MAINTENANCE .....	46
<b>13.</b>	<b>REFERENCES.....</b>	<b>48</b>
13.1	CHLORINE INSTITUTE REFERENCES .....	48
13.2	ASME STANDARDS.....	49
13.3	ASTM STANDARD DESIGNATIONS.....	49
13.4	OTHER REFERENCES .....	52
	<b>APPENDIX A: CHLORINE TRANSFER HOSE .....</b>	<b>53</b>
	<b>APPENDIX B: CHLORINE SERVICE – FLUID CATEGORY.....</b>	<b>64</b>
	<b>APPENDIX C: RECOMMENDATIONS TO MINIMIZE EFFECTS OF MOISTURE IN DRY CHLORINE SYSTEMS .....</b>	<b>68</b>
	<b>APPENDIX D: PAMPHLET 6 CHECKLIST .....</b>	<b>70</b>
	<b>DRAWINGS.....</b>	<b>72</b>
	DRAWING 101-7: EXCESS FLOW VALVE WITH REMOVABLE SEAT .....	73
	DRAWING 102-12: STUDS, NUTS AND GASKETS FOR CHLORINE TANK MANWAY COVERS AND VALVES .....	74
	DRAWING 104-9: STANDARD CHLORINE ANGLE VALVE ASSEMBLY.....	75
	DRAWING 106-6: EXCESS FLOW VALVE WITH REMOVABLE BASKET .....	76
	DRAWING 110-4: VALVES FOR CHLORINE CYLINDER AND TON CONTAINER ASSEMBLIES.....	77
	DRAWING 111-7: ¾ AND 1 INCH FUSIBLE PLUGS FOR CHLORINE TON CONTAINERS .....	78
	DRAWING 112-9: VALVE AND FUSIBLE PLUG FOR CHLORINE CYLINDERS AND TON CONTAINERS ..	79
	DRAWING 113-8: VALVE DETAILS FOR CHLORINE CYLINDERS AND TON CONTAINERS .....	80
	DRAWING 114-6: EXCESS FLOW VALVE WITH REMOVABLE SEAT .....	81
	DRAWING 118-5: CHLORINE TANK CAR UNLOADING CONNECTION.....	82
	DRAWING 130-5: STANDARD CHLORINE CYLINDER AND TON CONTAINER VALVE YOKE ADAPTERS.....	83
	DRAWING 131-4: CHLORINE CYLINDER VALVE YOKE .....	84
	DRAWING 136-8: CHLORINE EXPANSION CHAMBERS .....	85
	DRAWING 162-4: EXCESS FLOW VALVE WITH REMOVABLE SEAT .....	86
	DRAWING 171-3: SMALL UNION CONNECTION .....	87
	DRAWING 189-2: CLOSED YOKE CHLORINE CONTAINER VALVE .....	88

## 1. INTRODUCTION

### 1.1 SCOPE

This publication is intended to provide useful information concerning chlorine piping for both permanent production and use facilities, as well as temporary transportation systems. This pamphlet's objective is to offer practical suggestions in the selection of material suited for the indicated service. Use of materials other than those recommended herein may be technically desirable in specific producing/consuming sites.

This pamphlet does not intend to override specific technical needs. Underground (buried) chlorine piping system design is beyond the scope of this pamphlet and should be undertaken only by engineers experienced in that field. Recommendations given in CI Pamphlet 60 (13.1) may be a useful reference to the designer.

All parts of this pamphlet should be consulted before deciding on the components of a piping system. Listed are pipe, valves, and fittings suitable for use with dry chlorine in either the liquid or gaseous phase, at temperatures between -150°F (-101°C) and 300°F (149°C). Guidance regarding dry chlorine can be found in CI Pamphlet 100 (13.1). Material selection based on the recommendations of this pamphlet shall take into consideration the operating conditions and the possible corrosive nature of chlorine, particularly when moisture unintentionally enters systems. Sound engineering principles should be applied in the selection of all equipment.

The Chlorine Institute does not approve, rate, certify, or endorse any product or construction except for certain equipment used in transportation. In each such case, there is an approved Chlorine Institute drawing. If equipment does not comply in every respect with such drawings, its manufacturers are not authorized to use the Chlorine Institute name in advertising.

- It is recognized that facilities built prior to the publication of this edition of this pamphlet may be operating successfully without adhering to all recommendations contained herein. Operators of such facilities should evaluate discrepancies and validate that they do not pose disproportionate risks to safe operation or the environment. Continued operation without adhering to all aspects of this pamphlet is generally acceptable provided that: previous successful, long-term operation coupled with periodic hazard evaluations show that risks to safe operations and the environment are sufficiently low;
- The system does not violate applicable codes or regulations; and
- Consideration is given to modifying the system to meet recommendations contained in this edition of the pamphlet when redesign or replacement projects are planned.

### 1.2 CHLORINE INSTITUTE STEWARDSHIP PROGRAM

The Chlorine Institute exists to support the chlor-alkali industry and serve the public by fostering continuous improvements to safety and the protection of human health and the

environment connected with the production, distribution and use of chlorine, sodium and potassium hydroxides, and sodium hypochlorite; and the distribution and use of hydrogen chloride. This support extends to giving continued attention to the security of chlorine handling operations.

Chlorine Institute members are committed to adopting CI's safety and stewardship initiatives, including pamphlets, checklists, and incident sharing, that will assist members in achieving measurable improvement. For more information on the Institute's stewardship program, visit CI's website at [www.chlorineinstitute.org](http://www.chlorineinstitute.org).

### 1.3 DEFINITIONS AND ACRONYMS

In this pamphlet, the following meanings apply unless otherwise noted:

AEGL	Acute Exposure Guideline Levels
AIHA	American Industrial Hygiene Association
ANSI	American National Standards Institute, Inc.
API	American Petroleum Institute
ASME	American Society of Mechanical Engineers
ASTM	American Society for Testing and Materials
Balanced-Area Pressure Relief Valve (PRV)	A spring-loaded PRV which incorporates a bellows or other means of balancing the valve disc to minimize the effects of backpressure on the performance characteristics of the valve.
Charpy Test	The <b>Charpy impact test</b> , also known as the <b>Charpy v-notch test</b> , is a standardized high strain-rate test which determines the amount of energy absorbed by a material during fracture.
chlorine	The chemical element in either the liquid or gaseous state
CI	The Chlorine Institute
CGA	Compressed Gas Association
CPE	Chlorinated polyethylene elastomer
CWP	Cold working pressure
dry chlorine	Chlorine that does not meet the definition of "dry" will be considered "wet" and will have a moisture content that can cause a rapid corrosion of steel. See CI Pamphlet 100 (13.1) for a complete definition and technical summary.
ECTFE	Ethylene chlorotrifluoroethylene
EPA	U.S. Environmental Protection Agency
ERPG	Emergency Response Planning Guide

---

ETFE	Ethylene tetrafluoroethylene
FEP	Fluorinated ethylene propylene
gas purge	The use of clean, dry, oil-free compressed air or nitrogen, dried to a dew point of -40°F (-40°C) measured at the operating pressure
Hastelloy	A registered trademark of Haynes International, Inc.
IDLH	Immediately dangerous to life and health
Inconel	A registered trademark of Special Metals Corporation
Institute	The Chlorine Institute
Kalrez	A registered trademark of DuPont Elastomers
kPa	Kilopascal(s)
liquid hammer	A sudden velocity change of a flowing fluid (liquid or gas) which results in a pressure wave that travels through the fluid at the speed of sound for that fluid causing an audible sound; this sudden velocity change in liquid or gaseous chlorine piping is often the result of rapid vaporization or condensation due to large temperature differentials and the extremely low heat capacity and low heat of vaporization of chlorine.
MAWP	Maximum allowable working pressure
Monel	A registered trademark of Special Metals Corporation
MSS	Manufacturers Standardization Society of the Valve & Fittings Industry
NAHAD	National Association for Hose and Accessories Distribution
NDT	Non-Destructive Testing
NEMA	National Electrical Manufacturers Association
NIOSH	National Institute for Occupational Safety and Health
NFPA	National Fire Protection Association
NPS	Nominal pipe size
NPT	Nominal pipe thread
OD	Outside diameter
PFA	Perfluoroalkoxy

ppm	Parts per million (can be weight or volume basis)
psia	Pounds per square inch absolute
psig	Pounds per square inch gauge
PTFE	Polytetrafluoroethylene
PVDF	Polyvinylidene fluoride
SAE	Society of Automotive Engineers
Stellite	A registered trademark of Kennametal Stellite, Inc.
UNS	Unified Numbering System
Viton	A registered trademark of DuPont Performance Elastomers

#### 1.4 DISCLAIMER

The information in this pamphlet is drawn from sources believed to be reliable. The Institute and its members, jointly and severally, make no guarantee and assume no liability in connection with any of this information. Moreover, it should not be assumed that every acceptable procedure is included or that special circumstances may not warrant modified or additional procedures. The user should be aware that changing technology or regulations may require changes in the recommendations contained herein. Appropriate steps should be taken to ensure that the information is current when used. These recommendations should not be confused with federal, state, provincial, municipal, or insurance requirements, or with national safety codes.

#### 1.5 APPROVAL

The Institute's Health, Environment, Safety & Security Issue Team approved Edition 16 of this pamphlet on March 29, 2013.

#### 1.6 REVISIONS

Suggestions for revisions should be directed to the Secretary of the Institute.

##### 1.6.1 Significant Revisions in Current Edition

Significant updates to this revision as approved include:

Revision 16 of this pamphlet includes the addition of a section on fully-lined valves (4.1.9), a more robust section on liquid expansion chambers (5.5), recommendations on plastic pipe selections and discussion on gas permeability under vacuum (9), a caution on pneumatic testing (11.2.2), updated guidance on hydrostatic testing (appendix A, 2.3.1), and addition of a definition of deformation pressure (Appendix A, 2.6).

#### 1.7 REPRODUCTION

The contents of this pamphlet are not to be copied for publication, in whole or in part, without prior Institute permission.



---

## 2. GENERAL

### 2.1 PRECAUTIONS

Chlorine is a hazardous material. It is normally used and processed as a liquid or gas under pressure. For general precautions in chlorine handling, the reader should refer to CI Pamphlet 1 (13.1).

This pamphlet outlines practices that industry has found to be safe and environmentally sound. Extraordinary practices such as the use of double wall piping are not required as long as the system is installed, maintained and inspected per the recommendations contained herein.

Particular care must be taken as follows:

- a) Assure that all piping is thoroughly purged of chlorine before burning or welding. Dry chlorine can support combustion of carbon steel and other metals.
- b) Protect piping from overpressure where chlorine can be trapped between closed valves. Liquid chlorine has an unusually high coefficient of thermal expansion that can cause piping to rupture as temperature increases, unless the piping system is protected with items such as expansion chambers, relief devices, or other suitable means.
- c) Assure that dry chlorine systems are protected from the intrusion of moisture. Moisture from wet compressed air or from exposure to ambient air can cause severe corrosion and rapid failure of welds, valves, hoses, and fittings.
- d) Do not use titanium in dry chlorine service. Dry chlorine reacts with titanium to cause corrosion or combustion. Titanium can only be used with wet chlorine.
- e) Assure that dry chlorine systems are thoroughly cleaned and dried and are free of oils, grease, and other materials which would react with chlorine to cause fire, corrosion, pressure increase, or harmful deposits (Section 11).
- f) Inspect all chlorine piping systems at regular intervals for signs of leakage, internal or external corrosion, insulation failure, adequate identification and supports (Section 12).
- g) Consider fugitive emission issues when designing piping systems for chlorine.
- h) Assure liquid chlorine piping is adequately protected from liquid hammer damage. Chlorine liquid has a high density that can result in large hydraulic shock forces.
- i) When evacuating liquid chlorine piping systems, ensure nitrogen trichloride is not concentrated to dangerous levels (CI Pamphlet 152 (13.1)).

- j) Historically, producers have not designed chlorine piping systems for Category M Fluid Service (ASME B31.3). It is important to note that the decision to design to Category M rests with the system owner. Users may wish to incorporate provisions of Category M requirements that have been found to enhance safety.

## 2.2 CERTIFICATION

Manufacturers or suppliers of chlorine piping components must certify to the user, when requested, that their product complies with recommendations in this pamphlet. In addition, limitations and any deviations from the recommendations contained herein shall be specifically noted.

## 2.3 MATERIALS

This pamphlet provides minimal recommendations for the components of piping systems. In general, carbon steel or alloy steel piping are recommended for handling dry chlorine. The Institute believes these materials are suitable for the indicated service. Where reference is made to specific materials, other materials may be used so long as the user has evidence that the alternate materials are equal or superior in the intended service.

Specific components (e.g. piping, fittings, gaskets, nuts and bolts, valves, etc.) have been organized into service classes in Sections 3 and 4 according to the design pressure and temperature of the chlorine gas and liquid. These service classes are as follows:

Service Class	Fluid State	Design Pressure	Design Temperature
Class I	Gas Only	Vacuum to 150 PSIG (1034 kPa)	-20°F to 300°F (-29°C to 149°C)
Class II	Gas Only	Vacuum to 150 PSIG (1034 kPa)	-50°F to 300°F (-46°C to 149°C)
Class III	Gas Only	Vacuum to 150 PSIG (1034 kPa)	-150°F to 300°F (-101°C to 149°C)
Class IV <sup>1</sup>	Gas or Liquid	Vacuum to 300 PSIG (2068 kPa)	-20°F to 300°F (-29°C to 149°C)
Class V <sup>1</sup>	Gas or Liquid	Vacuum to 300 PSIG (2068 kPa)	-50°F to 300°F (-46°C to 149°C)
Class VI <sup>1</sup>	Gas or Liquid	Vacuum to 300 PSIG (2068 kPa)	-150°F to 300°F (-101°C to 149°C)

<sup>1</sup> Piping classes corresponding to the fluid state "gas or liquid" are to be used for all liquid-only lines and gas lines where the possibility of liquid entry exists or where there is the possibility that gas in a line may liquefy.

Chlorine has a low atmospheric boiling point, and its vapor pressure rises rapidly with increasing temperature. Therefore, it is important to select materials that have adequate strength and maintain ductility at low temperature. The following are several material selection examples based on industry experience:

- For service temperatures above -20°F (-29°C), fine grain carbon steel pipe such as ASTM A587 can be cold bent, but other carbon steel pipe should be normalized after bending. To ensure rigidity and protection from outside abuse, pipe of ¾" nominal size or larger should be used. Nonferrous and nonmetallic tubing and fittings of appropriate size may sometimes be used (Sections 7 & 9). Cast iron or malleable iron fittings and general-purpose valves are not recommended for chlorine service. Ductile iron per ASTM A395 may be used for valves and strainers designed for chlorine gas service (Class I) only.
- Temperatures below -20°F (-29°C) may be encountered in chlorine systems, and below this temperature some steels become brittle. ASTM A333 carbon steel and alloy steel pipe and corresponding fittings are recommended, with grades specific to the expected low temperature. Stainless steels of the 300 series have useful properties for low-temperature service, but can fail due to chloride-stress corrosion-cracking in the presence of moisture, particularly at ambient or elevated temperatures.
- Butt-welded and flanged joints are recommended for all sizes. Screwed and socket-welded joints are alternatives for nominal pipe sizes up through 1½" in some classes (Section 3).
- When thermally or electrically applied coatings are applied to fasteners for corrosion protection, the coating process should be reviewed to ensure against the possibility of hydrogen embrittlement or altered mechanical properties (detempering).
- For service temperatures between -20°F (-29°C) and 0°F (-18°C) where thermal shock or liquid hammer is anticipated, the use of impact-tested steels or the use of Class V material is advisable.
- There may be situations where the user contemplates chlorine service outside the process conditions defined in this pamphlet. In those cases, the user is advised to review each aspect of the service class in this pamphlet which is closest in process conditions to the contemplated use, individually determine which aspects of the recommendations are acceptable, and engineer revisions to those portions which are not acceptable.

## 2.4 SELECTION

All parts of this pamphlet should be consulted before selecting the components of a piping system. When making design decisions, the designer should consider variable operating conditions including start-ups, upsets, shutdowns, and system evacuation.

The recommendations contained herein are generally in accord with ASME B31.3 (13.2.8). Within that standard there are three fluid classifications. They are "D", "Normal

Fluid Service”, and “M”. Typically, chlorine piping systems have been designed for “Normal Fluid Service”, but elements of Category M design have appeal to users. The Institute position relative to Category M (Appendix B) design is as follows:

The owner is responsible for determining fluid class

- A single exposure to a very small quantity of chlorine does not cause irreversible harm.
- Current design practices have been adequate to prevent significant releases and several elements of Category M design would eliminate use of currently proven equipment.
- It is good practice for users to develop site-specific chlorine piping specifications that use the recommendations outlined herein as a base and consider including elements of Category M requirements (such as NDT examination) that enhance reliability at their sites.

## 2.5 WELDING

Specific details covering all situations for welding are beyond the scope of this pamphlet. However, welding of pipe must be performed by qualified individuals currently experienced in the specific metallurgy. Procedures and welder qualifications must be in accordance with ANSI/ASME BPV-IX (13.2.10) and ASME B31.3 (13.2.8). Care must be taken to insure the use of proper welding procedures; correct filler metal and adequate preheat or post heat treatment especially where alloy steel piping is used. Avoid welding pipe containing chlorine or chlorine residues. Piping containing chlorine or its residues must be adequately purged / evacuated to avoid a spontaneous ignition of iron and chlorine at elevated temperatures (See CI Pamphlet 1 (13.1)).

A welding non-destructive testing program should be in place where welded systems are contemplated. The program, at a minimum, should follow the examination guidelines outlined in ASME B31.3 (13.2.8).

## 3. **PIPE AND PIPING COMPONENTS**

This section provides minimum specifications for pipe, fittings, and components for dry chlorine piping systems. The Institute believes these materials are suitable for the service shown. Specific components have been arranged according to the Service Classes I through VI as indicated in Section 2.3 and according to the following breakdown:

- Threaded Construction
  - Classes I and IV
- Socket-welded Construction
  - Classes I, II, IV and V
- Butt-welded Construction
  - Classes I, II, III, IV, V and VI

The Institute has long recommended all the above construction types for chlorine service but as time has passed it has become clear that the preferred method of construction for all chlorine service pipe is butt-welded construction. Based on the ability to fully inspect all welds and insure high integrity connections through raised face flanges, this construction type is preferred over threaded connections which can corrode and leak over time due to the small threads that routinely get mauled or socket-welded connections in which a full penetration weld cannot be made, which is, by default, a weaker weld.

The Institute will continue to list components for both threaded and socket-welded connections for situations in which they must be used as with connections to transportation equipment. Users of this publication are urged to consider the use of butt-welded construction for new construction or replacement (maintenance) construction when practical.

<b>Table 3-1. Threaded Construction</b>				
<b>Component</b>	<b>Nominal Pipe Size (NPS)</b>	<b>Class I</b>	<b>Class IV</b>	<b>Classes II, III, V &amp; VI</b>
Pipe	Through 1½"	ASTM A106 Grade B Sch 80 carbon steel seamless ASME B36.10	ASTM A106 Grade B Sch 80 carbon steel seamless ASME B36.10	[See Note 3]
Fittings	Through 1½"	ASTM A105, Class 3000 forged steel threaded ASME B16.11 [See Note 1]	ASTM A105, Class 3000 forged steel threaded ASME B16.11 [See Note 1]	[See Note 3]
Flanges	Through 1½"	ASTM A105, Class 150 forged steel raised-face or tongue-and-groove, threaded ASME B16.5 [See Note 4]	ASTM A105, Class 300 forged steel raised-face or tongue-and-groove, threaded ASME B16.5 [See Note 4]	[See Note 3]
Unions, Hammer	Through 1½"	ASTM A105, Class 3000 forged steel lug nut unions, threaded	ASTM A105, Class 3000 forged steel lug nut unions, threaded	[See Note 3]
Branch Connections	Through 1½"	Fittings per Table 3-1 threaded tees, reducing tees, tees with swaged nipples or threaded olets. Bushings not recommended.	Fittings per Table 3-1 threaded tees, reducing tees, tees with swaged nipples or threaded olets. Bushings not recommended.	[See Note 3]
Bolts	All sizes	ASTM A193 Grade B7 alloy steel quenched and tempered, stud bolts and cap screws ASME B18.2.1 [See Notes 6 & 8]	ASTM A193 Grade B7 alloy steel quenched and tempered, stud bolts and cap screws ASME B18.2.1 [See Notes 6 & 8]	[See Note 3]
Nuts	All sizes	ASTM A194 Grade 2H carbon steel heavy hex nuts ASME B18.2.2 [See Note 6]	ASTM A194 Grade 2H carbon steel heavy hex nuts ASME B18.2.2 [See Note 6]	[See Note 3]

<b>Table 3-1. Threaded Construction (Cont'd.)</b>				
<b>Component</b>	<b>Nominal Pipe Size (NPS)</b>	<b>Class I</b>	<b>Class IV</b>	<b>Classes II, III, V &amp; VI</b>
Gaskets	All sizes	[See Note 7]	[See Note 7]	[See Note 3]
Gaskets Tongue & Groove Flanges	All sizes	Chemical lead with 2-4% antimony	Chemical lead with 2-4% antimony	[See Note 3]
Thread Dope	All sizes	PTFE tape [See Note 2]	PTFE tape [See Note 2]	[See Note 3]
Gasket Dope (if required)	All sizes	[See Note 5]	[See Note 5]	[See Note 3]
<p>Acronyms used in the above table are listed in Section 1.3. The complete titles of specifications are listed in Section 13.</p> <p>Note 1      Threaded connections should be minimized and used only when required.</p> <p>Note 2      Additional types of thread dopes that have been used successfully include PTFE paste and white lead paste. Paste, if used, must contain only materials suitable for chlorine service. In all cases, care must be taken to prevent the thread dope from entering the interior of the piping system.</p> <p>Note 3      Except for connections to transportation equipment and special circumstances, threaded construction should not be used for Classes II, III, V, and VI. In any case, threaded connections should not exceed 1½" NPS.</p> <p>Note 4      Two bolt flanges are acceptable in bulk container unloading systems (see CI Drawing 118 (13.1)) and have been used in rigid piping systems. Care must be taken to apply the gasket loading forces uniformly by tightening both bolts evenly.</p> <p>Note 5      Avoid lubricating the gaskets. Lubricants can attack some gaskets and can cause gaskets to blow out by reducing the friction between the gasket and flange. If Gasket Dope is required, use only non-chlorine reactive material (i.e. fluorocarbon grease). Refer to Chlorine Institute Pamphlet 95 for further information (13.1).</p> <p>Note 6      Threads shall be to ASME B1.1. Bolts shall have a Class 2A fit and nuts shall have a Class 2B fit.</p> <p>Note 7      The Institute's Pamphlet 95 (13.1) contains a current list of gaskets that have performed satisfactorily at member facilities.</p> <p>Note 8      Stud bolts and nuts are preferred on in-line piping components that do not have tapped threads. Cap screws may be used for threaded piping components and instrumentation.</p>				

<b>Table 3-2. Socket-Welded Construction - Classes I and IV</b>				
<b>Component</b>	<b>Nominal Pipe Size (NPS)</b>	<b>Class I</b>	<b>Class IV</b>	<b>Classes III &amp; VI</b>
Pipe	Through 1½"	ASTM A106 Grade B Sch 80 carbon steel, seamless ASME B36.10	ASTM A106 Grade B Sch 80 carbon steel, seamless ASME B36.10	[See Note 4]
Fittings	Through 1½"	ASTM A105, Class 3000 forged steel, socket weld ASME B16.11 [See Note 1]	ASTM A105, Class 3000 forged steel, socket weld ASME B16.11 [See Note 1]	[See Note 4]
Flanges	Through 1½"	ASTM A105, Class 150 forged steel raised-face or tongue-and-groove, socket weld ASME B16.5 [See Note 2]	ASTM A105, Class 300 forged steel raised-face or tongue-and-groove, socket weld ASME B16.5 [See Note 2]	[See Note 4]
Unions, Hammer	Through 1½"	ASTM A105 Class 3000 forged steel lug nut unions, socket weld	ASTM A105 Class 3000 forged steel lug nut unions, socket weld	[See Note 4]
Branch Connections	Through 1½"	Fittings per Table 3-2 socket-welded tees, reducing tees, tees with swaged nipples, or socket-weld olets. Socket-weld inserts are not recommended.	Fittings per Table 3-2 socket-welded tees, reducing tees, tees with swaged nipples, or socket-weld olets. Socket-weld inserts are not recommended.	[See Note 4]
Bolts	All sizes	ASTM A193 Grade B7 Alloy steel quenched and tempered, alloy steel stud bolts and cap screws ASME B18.2.1 [See Notes 6 and 8]	ASTM A193 Grade B7 Alloy steel quenched and tempered, alloy steel stud bolts and cap screws ASME B18.2.1 [See Notes 6 and 8]	[See Note 4]
Nuts	All sizes	ASTM A194 Grade 2H carbon steel heavy hex nuts ASME B18.2.2 [See Note 6]	ASTM A194 Grade 2H carbon steel heavy hex nuts ASME B18.2.2 [See Note 6]	[See Note 4]
Gasket	All sizes	[See Note 7]	[See Note 7]	[See Note 4]
Gasket Dope (if required)	All sizes	[See Note 3]	[See Note 3]	[See Note 4]

Acronyms used in the above table are listed in Section 1.3. The complete titles of specifications are listed in Section 13.

For notes applicable to Table 3-2 refer to notes after Table 3-3.

<b>Table 3-3. Socket-Welded Construction - Classes II and V</b>			
<b>Component</b>	<b>Nominal Pipe Size (NPS)</b>	<b>Class II</b>	<b>Class V</b>
Pipe	Through 1½"	ASTM A333 Grade 1 or Grade 6 Sch 80 carbon steel, seamless, ASME B36.10 (Charpy test at -50°F/-46°C)	ASTM A333 Grade 1 or Grade 6 Sch 80 carbon steel seamless, ASME B36.10 (Charpy test at -50°F/-46°C)
Fittings	Through 1½"	ASTM A350 Grade LF2 Class 1, Class 3000 forged steel, socket weld ASME B16.11 (Charpy test at -50°F/-46°C) [See Note 1]	ASTM A350 Grade LF2 Class 1, Class 3000 forged steel, socket weld ASME B16.11 (Charpy test at -50°F/-46°C) [See Note 1]
Flanges	Through 1½"	ASTM A350 Grade LF2 Class 1, Class 150 forged steel, raised-face or tongue-and-groove, socket weld ASME B16.5 (Charpy test at -50°F/-46°C) [See Note 2]	ASTM A350 Grade LF2 Class 1, Class 300 forged steel raised-face or tongue-and-groove, socket weld ASME B16.5 (Charpy test at -50°F/-46°C) [See Note 2]
Branch Connections	All sizes	Fittings per Table 3-3 socket-welded tees, reducing tees, tees with swaged nipples, or socket-weld olets. Socket-weld inserts are not recommended.	Fittings per Table 3-3 socket-welded tees, reducing tees, tees with swaged nipples, or socket-weld olets. Socket-weld inserts are not recommended.
Bolts	All sizes	ASTM A320 Grade L7 alloy steel stud bolts and cap screws ASME B18.2.1 (Charpy test at -150°F/-101°C) [See Notes 5, 6 and 8]	ASTM A320 Grade L7 alloy steel stud bolts and cap screws ASME B18.2.1 (Charpy test at -150°F/-101°C) [See Notes 5, 6 and 8]
Nuts	All sizes	ASTM A194 Grade 4 L or L7 alloy steel heavy hex nuts (Charpy test at -150°F/-101°C); ASME B18.2.2 [See Notes 5 and 6]	ASTM A194 Grade 4 L or L7 alloy steel heavy hex nuts (Charpy test at -150°F/-101°C); ASME B18.2.2 [See Notes 5 and 6]
Gaskets Tongue & Groove Flanges	All sizes	Chemical lead with 2-4% antimony	Chemical lead with 2-4% antimony
Gaskets	All sizes	[See Note 7]	[See Note 7]
Gasket Dope	All sizes	[See Note 3]	[See Note 3]



**Table 3-3. Socket-Welded Construction - Classes II and V (Cont'd.)**

Acronyms used in the above table are listed in Section 1.3. The complete titles of specifications are listed in Section 13.

- Note 1            Socket-welded connections should be minimized and used only when required. In any case, socket-welded connections should not exceed 1½" NPS.
  
- Note 2            Two-bolt flanges are acceptable in bulk container unloading systems (see CI Drawing 118), and have been used in rigid piping systems. Care must be taken to apply the gasket loading forces uniformly by tightening both bolts evenly.
  
- Note 3            Avoid lubricating the gaskets. Lubricants can attack some gaskets and can cause gaskets to blow out by reducing the friction between the gasket and flange. If Gasket Dope is required, use only non-chlorine reactive material (i.e. fluorocarbon grease). Refer to Chlorine Institute Pamphlet 95 (13.1) for further information.
  
- Note 4            Socket-welded construction should not be used in Classes III and VI.
  
- Note 5            ASTM A193 Grade B7M bolts and ASTM A194 Grade 2H or 2HM nuts may be substituted.
  
- Note 6            Threads shall be to ASME B1.1. Bolts shall have a Class 2A fit and nuts shall have a Class 2B fit.
  
- Note 7            The Institute's Pamphlet 95 (13.1) contains a current list of gaskets that have been tested and have performed satisfactorily by member companies.
  
- Note 8            Stud bolts and nuts are preferred on in-line piping components that do not have tapped threads. Cap screws may be used for threaded piping components and instrumentation.

<b>Table 3-4. Butt-Welded Construction - Classes I, II and III</b>				
<b>Component</b>	<b>Nominal Pipe Size (NPS)</b>	<b>Class I</b>	<b>Class II</b>	<b>Class III</b>
Pipe	Through 1½"	ASTM A106 Grade B Sch 80 carbon steel seamless ASME B36.10	ASTM A333 Grade 1 or Grade 6 Sch 80 carbon steel seamless or welded ASME B36.10 (Charpy test at -50°F/-46°C)	ASTM A333 Grade 3 Sch 80 alloy steel seamless or welded ASME B36.10 (Charpy test at -150°F/-101°C)
Pipe	2" through 4"	ASTM A106 Grade B or A53 Grade B Sch 40 or 80 Type E or S carbon steel ASME B36.10 [See Note 1]	ASTM A333 Grade 1 or Grade 6 Sch 40 or 80 carbon steel seamless or welded ASME B36.10 (Charpy Test at -50°F/-46°C) [See Note 1]	ASTM A333 Grade 3 Sch 40 or 80 alloy steel seamless or welded ASME B36.10 (Charpy test at -150°F/-101°C) [See Note 1]
Pipe	6" through 12"	ASTM A106 Grade B or A53 Grade B Sch 40, Type E or S carbon steel ASME B36.10	ASTM A333 Grade 1 or Grade 6 Sch 40 carbon steel seamless or welded (Charpy test at -50°F/-46°C) ASME B36.10	ASTM A333 Grade 3 Sch 40 alloy steel seamless or welded (Charpy test at -150°F/-101°C) ASME B36.10
Fittings, Wrought	Through 12"	ASTM A234 Grade WPB or WPB-W carbon steel (bore to match pipe) ASME B16.9	ASTM A420 Grade WPL 6 or WPL6-W carbon steel (Charpy test at -50°F/-46°C) (bore to match pipe) ASME B16.9	ASTM A420 Grade WPL3 or WPL3-W alloy steel (Charpy test at -150°F/-101°C) (bore to match pipe) ASME B16.9
Fittings, Forged	Through 12"	ASTM A105 forged steel (bore to match pipe) [See Note 4]	ASTM A350 Grade LF2 forged steel (Charpy tested at -50°F/-46°C) (bore to match pipe) [See Note 4]	ASTM A350 Grade LF3 forged alloy steel (Charpy tested at -150°F/-101°C) (bore to match pipe) [See Note 4]
Flanges	Through 12"	ASTM A105 Class 150 carbon steel raised-face, weld-neck or slip-on (bore to match pipe) ASME B16.5	ASTM A350 Grade LF2, Class 150 carbon steel raised-face, weld-neck or slip-on (Charpy test at -50°F/-46°C) (bore to match pipe) ASME B16.5	ASTM A350 Grade LF3, Class 150 alloy steel raised-face, weld-neck (Charpy test at -150°F/-101°C) (bore to match pipe) ASME B16.5
Branch Connections	Through 12"	Fittings per Table 3-4 Use tees for size on size, tees or reducing tees for header sizes 2" and smaller, and stub ins or welding olets for all other components	Fittings per Table 3-4 Use tees for size on size, tees or reducing tees for header sizes 2" and smaller, and stub ins or welding olets for all other components	Fittings per Table 3-4 Use tees for size on size, tees or reducing tees for header sizes 2" and smaller, and stub ins or welding olets for all other components

<b>Table 3-4. Butt-Welded Construction - Classes I, II and III (Cont'd.)</b>				
<b>Component</b>	<b>Nominal Pipe Size (NPS)</b>	<b>Class I</b>	<b>Class II</b>	<b>Class III</b>
Bolts	All sizes	ASTM A193 Grade B7, alloy steel quenched and tempered stud bolts and cap screws ASME B18.2.1 [See Note 3]	ASTM A320 Grade L7, alloy steel stud bolts and cap screws (Charpy test at -150°F/-101°C) ASME B18.2.1 [See Notes 3, 6 and 8]	ASTM A320 Grade L7, alloy steel stud bolts and cap screws (Charpy test at -150°F/-101°C) ASME B18.2.1 [See Notes 3 and 8]
Nuts	All sizes	ASTM A194 Grade 2H carbon steel heavy hex nuts ASME B18.2.2 [See Note 3]	ASTM A194 Grade 4 L or L7 alloy steel heavy hex nuts to be Charpy tested at -150°F/-101°C ASME B18.2.2 [See Notes 3 and 6]	ASTM A194 Grade 4 L or L7 alloy steel heavy hex nuts to be Charpy tested at -150°F/-101°C ASME B18.2.2 [See Note 3]
Gaskets	All sizes	[See Note 5]	[See Note 5]	[See Note 5]
Gasket Dope (if required)	All sizes	[See Note 2]	[See Note 2]	[See Note 2]

Acronyms used in the above table are listed in Section 1.3. The complete titles of specifications are listed in Section 13.

For notes applicable to Table 3-4, refer to notes after Table 3-5.

<b>Table 3-5. Butt-Welded Construction - Classes IV, V and VI</b>				
<b>Component</b>	<b>Nominal Pipe Size (NPS)</b>	<b>Class IV</b>	<b>Class V</b>	<b>Class VI</b>
Pipe	Through 1½"	ASTM A106 Grade B, Sch 80 carbon steel seamless ASME B36.10	ASTM A333 Grade 1 or Grade 6, Sch 80 carbon steel seamless or welded (Charpy test at -50°F/-46°C) ASME B36.10	ASTM A333 Grade 3 Sch 80 alloy steel seamless or welded (Charpy test at -150°F/-101°C) ASME B36.10
Pipe	2" through 4"	ASTM A106 Grade B or A53 Grade B, Sch 80, Type E or S carbon steel ASME B36.10 [See Note 7]	ASTM A333 Grade 1 or Grade 6, Sch 80 carbon steel seamless or welded (Charpy test at -50°F/-46°C) ASME B36.10	ASTM A333 Grade 3 Sch 80 alloy steel seamless or welded (Charpy test at -150°F/-101°C) ASME B36.10
Pipe	6" through 12"	ASTM A106 Grade B or A53 Grade B, Sch 40 or 80 Type E or S carbon steel ASME B36.10 [See Note 1]	ASTM A333 Grade 1 or Grade 6, Sch 40 or 80 carbon steel seamless or welded (Charpy test at -50°F/-46°C) ASME B36.10 [See Note 1]	ASTM A333 Grade 3 Sch 40 or 80 alloy steel seamless or welded (Charpy test at -150°F/-101°C) ASME B36.10 [See Note 1]

<b>Table 3-5. Butt-Welded Construction - Classes IV, V and VI (Cont'd.)</b>				
<b>Component</b>	<b>Nominal Pipe Size (NPS)</b>	<b>Class IV</b>	<b>Class V</b>	<b>Class VI</b>
Fittings, Wrought	Through 12"	ASTM A234 Grade WPB, or WPB-W carbon steel (bore to match pipe) ASME B16.9	ASTM A420 Grade WPL6 or WPL6-W steel (Charpy test at -50°F/-46°C)(bore to match pipe) ASME B16.9	ASTM A420 Grade WPL3, alloy steel (Charpy test at -150°F/-101°C) (bore to match pipe) ASME B16.9
Fittings, Forged	Through 12"	ASTM A105 forged steel (bore to match pipe) [See Note 4]	ASTM A350 Grade LF2 forged steel (bore to match pipe) (Charpy test at -50°F/-46°C) [See Note 4]	ASTM A350 Grade LF3 forged alloy steel (bore to match pipe) (Charpy test at -150°F/-101°C) [See Note 4]
Flanges	Through 12"	ASTM A105 Class 300 carbon steel raised-face, weld-neck or slip-on (bore to match pipe) ASME B16.5	ASTM A350 Grade LF2, Class 300 carbon steel raised-face, weld-neck or slip-on (Charpy test at -50°F/-46°C) (bore to match pipe) ASME B16.5	ASTM A350 Grade LF3, Class 300 alloy steel raised-face, weld-neck (Charpy test at -150°F/-101°C) ASME B16.5
Branch Connections	Through 12"	Fittings per Table 3-5 Use tees for size on size, tees or reducing tees for header sizes 2" and less, and stub ins or welding olets for all other connections	Fittings per Table 3-5 Use tees for size on size, tees or reducing tees for header sizes 2" and less, and stub ins or welding olets for all other connections	Fittings per Table 3-5 Use tees for size on size, tees or reducing tees for header sizes 2" and less, and stub ins or welding olets for all other connections
Bolts	All sizes	ASTM A193 Grade B7 alloy steel quenched and tempered, stud bolts and cap screws ASME B18.2.1 [See Notes 3 and 8]	ASTM A320 Grade L7 alloy steel stud bolts and cap screws (Charpy test at -150°F/-101°C) ASME B18.2.1 [See Notes 3, 6 and 8]	ASTM A320 Grade L7 alloy steel stud bolts and cap screws (Charpy test at -150°F/-101°C) ASME B18.2.1 [See Notes 3 and 8]
Nuts	All sizes	ASTM A194 Grade 2H heavy hex nuts carbon steel ASME B18.2.2 [See Note 3]	ASTM A194 Grade 4 L or L7 heavy hex nuts alloy steel (Charpy test at -150°F/-101°C) ASME B18.2.2 [See Notes 3 and 6]	ASTM A194 Grade 4 L or L7 heavy hex nuts alloy steel (Charpy test at -150°F/-101°C) ASME B18.2.2 [See Note 3]
Gaskets	All sizes	[See Note 5]	[See Note 5]	[See Note 5]
Gasket Dope (if required)	All sizes	[See Note 2]	[See Note 2]	[See Note 2]

Acronyms used in the above table are listed in Section 1.3. The complete titles of specifications are listed in Section 13.

- 
- Note 1 The decision to use Schedule 40 or Schedule 80 pipe should be based on sound engineering judgment taking into consideration such factors as internal and external corrosion allowances, the presence of insulation (which may hide and/or accelerate external corrosion), unsupported span versus allowable pipe deflection, and the need for greater mechanical strength in the piping system.
- Note 2 Avoid lubricating the gaskets. Lubricants can attack some gaskets and can cause gaskets to blow out by reducing the friction between the gasket and flange. If Gasket Dope is required, use only non-chlorine reactive material (i.e. fluorocarbon grease). Refer to Chlorine Institute Pamphlet 95 for further information.
- Note 3 Threads shall be to ASME B1.1. Bolts shall have a Class 2A fit and nuts shall have a Class 2B fit.
- Note 4 The reference standard will vary depending on the forge fitting used.
- Note 5 The Institute's Pamphlet 95 (13.1) contains a list of gaskets that have performed satisfactorily at member facilities.
- Note 6 ASTM A193 Grade B7M bolts and ASTM A-194 Grade 2H or 2HM nuts may be substituted.
- Note 7 For gas-only systems, where system pressure precludes use of Class I components, Schedule 40 pipe is acceptable.
- Note 8 Stud bolts are preferred on in-line piping components that do not have tapped threads. Cap screws may be used for threaded piping components and instrumentation.

#### **4. VALVES**

Valving for chlorine service requires special attention by all associated with the application. This includes the manufacturer, the supplier, the installer, the operator, and the maintainer. Chlorine service valves are highly engineered products and cannot be considered a routine commodity valve application. An understanding by all involved of the following sub-sections will provide for a successful application.

This section will discuss the types of valves currently in service, the criteria for selection of valve features, valve section tables, materials of construction tables, valve testing guidelines, cleaning and packaging guidelines.

The information presented is based on extensive experience of the Institutes membership and relevant information furnished by valve suppliers. There was no intention to exclude the use of other valve types and materials provided there has been sufficient testing and experience to ensure safe operation. The information on valves does not cover the requirements for the testing of prototype valves.

##### **4.1 TYPES OF VALVES**

The valves commonly employed in dry chlorine service are the globe, ball, plug, and butterfly types. Each valve is available in several basic body patterns, employing different design features often suited to a particular service and/or specific application.

For example, globe valves in several angle-body patterns are used extensively for chlorine shipping containers, ranging from small cylinders to 90-ton rail tank cars; whereas, the upright-pattern globe valve is more commonly used in facility piping systems.

#### 4.1.1 Globe Valves

Globe valves offer several important safety features, including tight shutoff in both directions (bi-directional seating) without trapping liquid inside cavities, multi-turn operation that prevents quick (and sometimes accidental) opening and closing, and a positive means to verify valve position (open or closed).

The recommended configuration includes a blow-out proof stem, a bolted bonnet employing four (4) bolts minimum, and a gland with outside screw and yoke (OS&Y) for external packing gland adjustment. Either metal-to-metal seating employing Stellite hard-facing or soft-seating using a PTFE insert will provide satisfactory service.

Particular attention should be paid to the design of the stuffing box since even minute stem leakage will cause corrosion of the valve stem by means of chlorine reacting with humid air. For this reason a bellows seal or a long stuffing box, using either PTFE or flexible graphite packing and a Hastelloy C-276 (UNS N10276) and C22 (UNS N06022) stem, can be chosen for extended service life.

#### 4.1.2 Ball Valves

Ball valves can provide tight shutoff and minimum resistance to flow when fully open. They are generally easier to operate than plug valves of equal size. Some maintain that the 1/4-turn stem movement lends itself to an inherently more reliable stem seal design. Ball valves should incorporate a blow-out proof stem design and a means to externally adjust the stem seal. The sealing material generally is a fluoropolymer resin, although fluoroelastomer O-rings are sometimes employed as the outer secondary seal.

Ball valves may be furnished either full-bore or reduced-bore. Flanged valves may have either a long (standard) or short body pattern. Full-bore ball valves have openings throughout the length of the valve with a diameter equal to their nominal pipe size.

Ball valve design must ensure that excess pressure, resulting from expansion of liquid chlorine trapped in the ball and body cavity when the valve is closed, will relieve spontaneously in the direction of higher line pressure. This relief may be accomplished by providing a relief hole in the ball, providing a passage in the body to the high pressure side, or by using cavity pressure self-relieving seats.

If the relieving method is directional (bored hole or passage), the valve body must be supplied with positive indication of the direction of pressure tightness. If it is possible to reverse this direction through improper reassembly of parts, a stainless steel tag with precautions must be securely attached to the valve.

Anti-static devices can be used to insure the electrical continuity between the valve stem and the body.

### 4.1.3 Plug Valves

Plug valves can be used for chlorine service and have generally provided satisfactory service. Their primary drawback is a need to balance turning torque and shutoff sealing capability. Like the ball valve, this valve can provide tight shutoff and, with the 1/4-turn stem movement, lends itself to an inherently more reliable stem seal design than one employing linear stem travel.

Plug valves have an inherent blow-out proof stem design and should be provided with a means to externally adjust the stem seal. The sealing material generally employed is a fluoropolymer resin.

Plug valves normally have a reduced bore and like the ball valve are also likely to trap liquid chlorine when closed. Therefore, the plug and body cavities also must be provided with a relief hole vented toward the direction of higher pressure.

If the relieving method is directional (bored hole or passage), the valve body must be supplied with positive indication of the direction of pressure tightness. If it is possible to reverse this direction through improper reassembly of parts, a stainless steel tag with precautions must be attached to the valve.

### 4.1.4 Soft-Seated "High-Performance" Butterfly Valves

Soft-seated, high-performance butterfly valves can be used in chlorine applications, particularly in the larger pipe sizes. These valves are distinguished from fully-lined butterfly valves primarily through their ANSI rated pressure capability.

Most soft-seated, high-performance butterfly valves use standard adjustable packing, a wetted shaft/disc arrangement and a one-piece soft-lip seal.

Soft-seated butterfly valves can provide tight shutoff and, with the 1/4-turn stem movement, lends itself to an inherently more reliable stem seal design than the rising stem valve.

### 4.1.5 Fully-Lined Butterfly Valves

Fully-lined butterfly valves can be used in wet or dry chlorine gas applications. No metallic part comes in contact with the media, as all internal surfaces of the valves are lined with a fluoropolymer resin. The fully-lined butterfly valve should incorporate a blow-out proof stem design.

The fully-lined butterfly valve can provide tight shutoff and, with the 1/4-turn stem movement, lends itself to an inherently more reliable stem seal design than the rising stem valve.

The fluoropolymer resin liner (seat) is given its resiliency by a fluoroelastomeric backup liner. This back-up liner is located behind the fluoropolymer resin liner and is not exposed to the media.

### 4.1.6 Single-Seated Segmented Ball Valves

These valves differ from conventional ball valves in that they do not trap liquid when closed. Seat material and design and the resulting ability to provide tight shutoff is

dependent on the application (on-off or control). This valve is typically used as a control valve.

#### 4.1.7 Fully-Lined Ball Valves

Fully-lined ball valves can be used in wet or dry chlorine gas applications. No metallic part comes in contact with the media, as all internal surfaces of the valve are lined with a fluoropolymer resin. Like metal ball valves, the fully-lined ball valve can provide tight shutoff and, with the 1/4-turn stem operation, lends itself to an inherently more reliable stem seal design than the rising stem valve. The fully-lined ball valve should incorporate a blow-out proof stem design and a means to externally adjust the stem seal. The stem sealing material is generally a fluoropolymer resin.

Fully-lined ball valves may be furnished in either full-bore or reduced-bore designs with flanged end connections. Due to the thickness of the fluoropolymer lining, full-bore valves will have port openings which are generally less than their nominal pipe size.

Fully-lined ball valves are limited to gas service. However, designs must ensure that excess pressure, resulting from expansion of liquid chlorine inadvertently trapped in the ball and body cavity, will relieve spontaneously in the direction of higher line pressure. This relief is usually accomplished by providing a relief hole in the ball or by providing a cavity relief seat design.

If the relieving method is directional, the valve body must be supplied with positive indication of the direction of pressure tightness. If it is possible to reverse this direction through improper reassembly of parts, a stainless steel tag with precautions must be securely attached to the valve.

#### 4.1.8 Rising Stem Ball Valves

These valves combine the high seating pressure of a globe valve with the ability to achieve full port flow characteristics of ball valves. They do not trap liquid when shut off. The falling action of the stem acts through a cam device to turn the ball from the open to closed position. When the ball reaches the closed position the final action of the stem/cam forces the ball against the seat. Rising action of the stem reverses the action.

#### 4.1.9 Fully-Lined Plug Valves

Fully-lined plug valves can be used in wet or dry, liquid or gas, chlorine applications. No metallic parts come in contact with the media, as all internal surfaces of the valve are lined with a fluoropolymer resin. Like a metal plug valve, a fully-lined plug valve can provide tight shutoff, and, with 1/4 turn stem movement, lends itself to an inherently more reliable stem seal design than one employing linear stem travel.

Fully-lined plug valves (that have a one piece plug and stem design) have an inherent blow-out proof stem design and should be provided with a means to externally adjust the stem seal. The sealing material generally employed is a fluoropolymer resin.

Fully-lined plug valves normally have a reduced bore and are likely to trap liquid when closed. Therefore, the plug and body cavity must be provided with a relief hole vented toward the direction of the higher pressure. If the relieving method is directional (bored hole or passage), the valve body must be provided with positive indication of the direction of pressure tightness (correct flow direction). If it is possible to reverse this



direction through improper reassembly of parts, a stainless steel tag with precautions (indication of correct flow direction) must be attached to the outside of the valve.

#### 4.2 GENERAL VALVE SELECTION CRITERIA

When specifying valves for chlorine applications it is important to consider the following factors.

##### 4.2.1 Stem Seal

When dealing with applications which have frequent or large temperature fluctuations, the specifier should consider alternative methods of stem sealing such as bellows seal or live-loaded packing to prevent a leak through the stem seal.

##### 4.2.2 Directional Shutoff

If the application calls for bi-directional shutoff, a unidirectional valve should not be used.

##### 4.2.3 Ambient Temperature

Ambient temperatures and process temperature should be considered during material selection.

##### 4.2.4 Potential for Wet Chlorine

When selecting valves for an application where the chlorine is normally dry but has the potential to become wet as defined in CI Pamphlet 100 (13.1), or where corrosion of metallic parts has been experienced, consideration should be given to choosing materials suited for both applications. For example, most fully-lined plug and ball valves have cast ductile iron (ASTM-A395) bodies and bonnets for the pressure parts. Ductile iron is suitable for Class I service. However, for other Class services, the body and bonnet must have materials of construction that are in accordance with Table 4-8, Valve Material Selection Guide. In addition, the materials of construction for the valve parts must be able to meet the design pressure and temperature limits as indicated in Section 2.3.

##### 4.2.5 Throttling

Valves used in throttling applications can experience extremely low temperatures due to the high differential pressure. When specifying a valve for those applications, consider selecting one that meets the classification for the lowest temperature anticipated.

Engineering principles for sizing the valve should be used to ensure flashing and cavitation does not take place. Modified trim or characterized ports might be required.

##### 4.2.6 Potential of Solids, Impurities and Contaminants

Under certain conditions, impurities and contaminants which can affect valve performance may be present in dry chlorine systems. Consideration should be made for such conditions in the selection of valve type and materials of construction.

In particular, ferric chloride and sodium sulfate compounds can accumulate in the low velocity regions of valve bodies or 'stick' to protruding parts inside a valve like a plug

inside a globe valve. To help prevent the build-up of these materials it is advisable to stroke the valves periodically to dislodge the accumulated material. If too much time passes between stroking a valve, the materials can completely solidify and harden most likely rendering the valve incapable of a tight shutoff. Sometimes when the valve is repeatedly stroked, even after sitting for a long period, the accumulated materials can be freed and the valve shut.

#### 4.2.7 Chloride Stress Corrosion

Stressed parts of a valve that are wetted or can be exposed to chlorine due to leakage (i.e. stems, plugs, fasteners and spring washers) should not be made of 300 series stainless steel.

#### 4.3 VALVE SELECTION TABLES

A valve selection guide is provided in Tables 4-1 through 4-7. These tables are intended for use in selecting various types of valves that have been found satisfactory in chlorine service. It is not intended to prevent the use of valve types other than those designated as "satisfactory" in a particular service class. However, the user is cautioned against such practice unless ample testing has been conducted, with documentation, to assure safe operation.

<b>Table 4-1. Globe Valves</b>								
<b>Nominal Pipe Size (NPS)</b>	<b>Common End Connect</b>	<b>Primary Form &amp; Rating</b>	<b>Class I</b>	<b>Class II</b>	<b>Class III</b>	<b>Class IV</b>	<b>Class V</b>	<b>Class VI</b>
Through 1½"	Threaded [See Note 1]	Forged API Class 800	S	--	NR	S	NR	NR
	Socket-Welded	Forged API Class 800	S	S	NR	S	S	NR
All sizes	Flanged	Forged or Cast ASME Classes 150 or 300	S	S	S	S	S	S
	Butt-Welded	Forged or Cast ASME Classes 150 or 300	S	S	S	S	S	S
<b>Legend:      S = Satisfactory                      NR = Not Recommended                      -- = Insufficient Experience</b>								
Note 1      Except for connections to transportation equipment, instruments, and special process equipment, flanged valves are recommended for Classes II, III, V, and VI.								

Table 4-2. Unlined Ball Valves								
Nominal Pipe Size (NPS)	Common End Connect	Primary Form & Rating	Class I	Class II	Class III	Class IV	Class V	Class VI
Through 1½"	Threaded [See Note 1]	Forged or Cast ASME Classes 150 or 300 minimum pressure rating	S	S	NR	S	NR	NR
All sizes	Flanged	Forged or Cast ASME Classes 150 or 300	S	S	S	S	S	S
<b>Legend: S = Satisfactory NR = Not Recommended -- = Insufficient Experience</b>								
Note 1 Except for connections to transportation equipment, instruments, and special process equipment, flanged valves are recommended for Classes II, III, V, and VI.								

Table 4-3. Unlined Plug Valves								
Nominal Pipe Size (NPS)	Common End Connect	Primary Form & Rating	Class I	Class II	Class III	Class IV	Class V	Class VI
Through 1½"	Threaded [See Note 1]	Forged or Cast ASME Classes 150 or 300 minimum pressure rating	S	S	NR	S	NR	NR
All sizes	Flanged	Cast ASME Classes 150 or 300	S	S	S	S	S	S
<b>Legend: S = Satisfactory NR = Not Recommended -- = Insufficient Experience</b>								
Note 1 Except for connections to transportation equipment, instruments, and special process equipment, flanged valves are recommended for Classes II, III, V, and VI.								

**Table 4-4. High-Performance Butterfly Valves**

Nominal Pipe Size (NPS)	Common End Connect	Primary Form & Rating	Class I	Class II	Class III	Class IV	Class V	Class VI
All sizes	Wafer	Plate or Cast ASME Classes 150 or 300	S	S	--	S	S	--
All sizes	Lugged	Plate or Cast ASME Classes 150 or 300	S	S	--	S	S	--
All sizes	Flanged	Cast ASME Classes 150 or 300	S	S	--	S	S	--
<b>Legend: S = Satisfactory NR = Not Recommended -- = Insufficient Experience</b>								

**Table 4-5. Fully-Lined Butterfly Valves**

Nominal Pipe Size (NPS)	Common End Connect	Primary Form & Rating	Class I	Class II	Class III	Class IV	Class V	Class VI
All sizes	Wafer	Cast ASME Class 150 psig CWP	S	--	NR	NR	NR	NR
All sizes	Lugged	Cast ASME Class 150 psig CWP	S	--	NR	NR	NR	NR
<b>Legend: S = Satisfactory NR = Not Recommended -- = Insufficient Experience</b>								

<b>Table 4-6. Single-Seated Segmented Ball Valves</b>								
<b>Nominal Pipe Size (NPS)</b>	<b>Common End Connect</b>	<b>Primary Form &amp; Rating</b>	<b>Class I</b>	<b>Class II</b>	<b>Class III</b>	<b>Class IV</b>	<b>Class V</b>	<b>Class VI</b>
All sizes	Wafer	Cast ASME Classes 150 or 300	S	S	--	S	S	--
All sizes	Flanged	Forged or Cast ASME Classes 150 or 300	S	S	--	S	S	--
<b>Legend</b>	<b>S = Satisfactory</b>		<b>NR = Not Recommended</b>			<b>-- = Insufficient Experience</b>		

<b>Table 4-7. Fully-Lined Valves</b>								
<b>Nominal Pipe Size (NPS)</b>	<b>Common End Connect</b>	<b>Primary Form &amp; Rating</b>	<b>Class I</b>	<b>Class II</b>	<b>Class III</b>	<b>Class IV</b>	<b>Class V</b>	<b>Class VI</b>
<b>Fully-lined Ball</b>								
All sizes	Flanged	Forged or Cast ASME Class 150	S	NR	NR	NR	NR	NR
<b>Fully-lined Plug</b>								
All sizes	Flanged	Forged or Cast ASME Class 150 and 300	S	NR	NR	S	NR	NR
<b>Legend</b>	<b>S = Satisfactory</b>		<b>NR = Not Recommended</b>			<b>-- = Insufficient Experience</b>		

4.4 VALVE MATERIALS TABLE

Table 4-8 lists materials recommendations that have proven to be suitable for valve parts in dry chlorine service. Materials are listed by the applicable standard/material designations. This guide is not intended to prevent the substitution of other materials known to be suited for the intended chlorine service as agreed upon between the manufacturer and purchaser. The use of higher class of materials may be substituted for lower class of materials.

<b>Table 4-8. Valve Material Selection Guide</b>				
<b>Product Forms</b>	<b>Parts</b>	<b>Classes I &amp; IV</b>	<b>Classes II &amp; V</b>	<b>Classes III &amp; VI</b>
Castings	Bodies, Bonnets, & Covers	ASTM A216 Grade WCB A216 Grade WCC A395 [See Note 1] A352 Grade LCA (to -25°F/-32°C) [See Note 12]	ASTM A352 Grade LCB or LCC (to -50°F/-46°C) A352 Grade LC1 (to -75°F/-59°C) A352 Grade LC2 (to -100°/-73°C) [See Notes 11 and 12]	ASTM A352 Grade LC3 (-150°F/-101°C) [See Note 12]
Forgings	Bodies, Bonnets & Covers	ASTM A105 A181 Classes 60 & 70 A182 Grade F1 A350 Grade LF1 (to -25°F/-32°C)	ASTM A350 Grade LF2 (to -50°F/-46°C) [See Note 11]	ASTM A350 Grade LF3 (-150°F/-101°C)
Rolled Plates & Shapes	Bodies, Bonnets & Covers	ASTM A516 Grade 70	ASTM A516 Grade 55, 60, & 65 (Charpy test at -50°F/-46°C) [See Note 11]	ASTM A203 Grade E (Charpy test at -150°F/-101°C)
Body, Bonnet & Cover Bolting	Bolts & Stud Bolts	ASTM A193 Grade B7	ASTM A320 Grade L7 (Charpy test at -150°F/-101°C) [See Notes 13 and 14]	ASTM A320 Grade L7 (Charpy test at -150°F/-101°C)
	Nuts	ASTM A194 Grade 2H heavy hex nuts	ASTM A194 Grade 4 heavy hex nuts (Charpy test at -150°F/-101°C) [See Note 13]	ASTM A194 Grade 4 heavy hex nuts (Charpy test at -150°F/-101°C) [See Note 13]
Other Metal Parts [See Note 3]	Stems (Shafts)	Hastelloy C22 (UNS N06022), C-276 (UNS N10276) Monel 500 (UNS N05500) Monel 400, R405 (UNS N04400 & N04405) [See Note 6]	Hastelloy C22 (UNS N06022),C-276 (UNS N10276) Monel 500 (UNS N05500) Monel 400, R405 (UNS N04400 & N04405) [See Note 6]	Hastelloy C22 (UNS N06022),C-276 (UNS N10276) Monel 500 (UNS N05500) Monel 400, R405 (UNS N04400 & N04405) [See Note 6]
	Balls, Tapered Plugs, & Discs	Monel 400 (UNS N04400) [See Note 2]	Monel 400 (UNS N04400) [See Note 2]	Monel 400 (UNS N04400) [See Note 2]

<b>Table 4-8. Valve Material Selection Guide (Cont'd.)</b>				
<b>Product Forms</b>	<b>Parts</b>	<b>Classes I &amp; IV</b>	<b>Classes II &amp; V</b>	<b>Classes III &amp; VI</b>
Other Metal Parts [See Note 3]	Bellows [See Note 8]	Monel 400, R405, (UNS N04400 & N04405) Hastelloy C-276 (UNS N10276)	Monel 400, R405 (UNS N04400 & N04405) Hastelloy C -276 (UNS N10276)	Monel 400, R405 (UNS N04400 & N04405) Hastelloy C-276 (UNS N10276)
	Seats & Discs, Wedge Facings	[See Notes 4 & 5]	[See Notes 4 & 5]	[See Notes 4 & 5]
	Other Parts	[See Note 5]	[See Note 5]	[See Note 5]
Non-Metallic Parts	Seats, Sleeves & Seals	Fluoropolymer Resin	Fluoropolymer Resin	Fluoropolymer Resin
	Packing	Flexible graphite or Fluoropolymer resin. [See Note 10]	Fluoropolymer resin [See Note 10]	Fluoropolymer resin. [See Note 10]
	Bonnet/Bonnet Gasket	Fluoropolymer resin [See Notes 7, 9, 10]	Fluoropolymer resin [See Notes 7, 9, 10]	Fluoropolymer resin [See Notes 7, 9, 10]
The complete titles of specifications are listed in Section 13.				
Note 1	Ductile iron per ASTM A395 may be used for valves in chlorine service in Class I service.			
Note 2	Hastelloy C (UNS N10002) and Hastelloy C-276 (UNS N10276) affords superior corrosion resistance over Monel.			
Note 3	Use Monel Alloy 400 (UNS N04400) per ASTM B564 (annealed) for forgings and ASTM B127 (annealed) for plates.			
Note 4	Hard-faced seating surfaces of Stellite 21 (UNS R30021) and/or Stellite 6 (UNS R30006) are recommended for metal seating surfaces prone to the combined effects of corrosion and erosion. Monel K500 (UNS N05500) also possesses good hard-facing properties. Integral seats eliminate corrosion and leakage associated with screwed in seats.			
Note 5	Other parts (such as yokes, yoke nuts, glands, gland bushings, studs, and hand-wheels) shall be of material suitable for the service and as agreed upon between manufacturer and purchaser. Series 300 stainless steels should not be used for bolts, nuts, and studs (2.3).			
Note 6	Valve stems of Hastelloy C22 (UNS N06022) and Hastelloy C-276 (UNS N10276) can improve operability and minimize leakage through the stuffing box by extending the integrity of the stem sealing surfaces which are most prone to moisture penetration and accelerated corrosion. Monel K500 (UNS N05500) also possesses good hard-facing properties. One piece construction for valve stems is preferred.			
Note 7	PTFE should only be used in a fully-confined joint.			
Note 8	Bellows shall be designed for a minimum of 10,000 cycles and to operate at the maximum allowable working pressure of the valve at ambient temperature.			

**Table 4-8. Valve Material Selection Guide (Cont'd.)**

Note 9	Spiral wound Monel 400 (UNS N04400) or Hastelloy C-276 (UNS N10276) with PTFE or graphite.
Note 10	Although asbestos is not recommended for packing and/or bonnet/bonnet gaskets, it may be present in older valves. In that case, only individuals familiar with proper handling procedures and techniques should be allowed to work with asbestos. In addition, regulations may limit the handling and use of asbestos even in older valves.
Note 11	Type 316/316L stainless steel (ASTM A351/A744 Gr CF8M/CF3M) valves or components can be used in specialized service based on long-term end-user experience. Use in new locations should be limited to installations which have been thoroughly evaluated and performance tested (including a metallurgical evaluation).
Note 12	Castings shall be traceable, conforming to the ASTM grade listed.
Note 13	ASTM A193 Grade B7M bolts and ASTM A194 Grade Grade 2H or 2HM nuts may be substituted.
Note 14	Stainless steel bolting should not be used. Alloy 20 bolting is recommended.

#### 4.5 VALVE PREPARATION - IDENTIFICATION REQUIREMENTS

All valves identified by the manufacturer as meeting the recommendations in this pamphlet for chlorine service shall meet the following requirements.

##### 4.5.1 Valve Testing

Each valve shall be subjected to the following pressure tests:

- a shell test in accordance with API 598 (13.4.3) at a minimum of 1.5 times the 100°F (38°C) rating rounded off to the next higher 25 psig increment or a body hydrostatic test at 1.5 times the 100°F (38°C) rating rounded off to the next 25 psig increment prior to assembly.
- all shutoff valves shall be closure tested with inert gas or air in accordance with API 598 (13.4.3). There shall be no leakage for the minimum specified test duration.

##### 4.5.2 Cleaning and Packaging

All metallic valves shall be degreased, specially cleaned, dried, and prepared for use in chlorine service including the use of special chlorine compatible lubricants for valve assembly (13.1). Valves shall be packaged in a manner which prevents moisture from entering the body once preparation is complete. Care should be taken by the receiver to protect the integrity of the packaged valves until they are placed in service.

Fully-lined valves should be assembled by the manufacturer using parts that are cleaned for chlorine service and a chlorine compatible lubricant (if required). After leak and/or pressure testing, plug, ball, and globe valves should be disassembled, cleaned and dried to remove trapped moisture within cavities. Fully-lined butterfly valves do not have to be



disassembled, but should be cleaned and dried. The valve should then be packaged so that the liner and valve internals are protected from damage. Lined valves do not necessarily need to be packaged air tight to prevent moisture from entering the valve. Humidity and/or moisture will not affect a lined valve like a metallic unlined valve. Corrosion will take place over time in an unlined metallic valve body if the valve is not kept dry. The key for a lined valve in chlorine service is to insure that the valve is clean and dry, both inside and on the flange faces before installation. A final cleaning and drying may also be performed in the field just prior to installation.

#### 4.5.3 Identification

If a valve passes the leak testing specified in Section 4.5.1 and has been degreased, cleaned, dried and packaged according to the requirements in Section 4.5.2, then the valve is considered ready for chlorine service. A securely attached tag designating the valve has been cleaned and tested for chlorine service in accordance with Chlorine Institute Pamphlet 6 will be used by manufacturers to indicate the valve has been prepared for service.

### 5. OTHER COMPONENTS

Components other than pipe, valves, and fittings that commonly are used in chlorine piping systems are addressed in this section.

#### 5.1 RUPTURE DISCS

Rupture discs in chlorine service should be installed with the understanding that these devices do not provide reseating capabilities such as those provided by a pressure relief valve. Once the disc has ruptured, the process fluid will continue to escape through the disc until blocked by some other means. For this reason, these discs are used most commonly in conjunction with a pressure relief device or expansion chamber. They function well under a pressure relief valve as a preventative measure against corrosion. Rupture discs used in conjunction with expansion chambers are referenced in CI Drawing 136. Vacuum support should be included, where appropriate.

Common materials used in the construction of rupture disc components are:

- disc holder: forged carbon or alloy steel (connection type and pressure rating of disc holder should conform to the class specification of the flanges and piping systems)
- disc: Monel alloys K500 and R405 (UNS N05500 and N04405)
- tantalum, armored impervious graphite, silver, Hastelloy C and C-276 (UNS N1002 and UNS N10276)

**CAUTION:** Non-fragmenting disks should be used under pressure relief valves. Fragmentation of the disc upon rupture may damage valve parts or plug the valve, rendering it ineffective as a pressure relief device. Disc fragments may be projected out the vent pipe and impede the reseating of the pressure relief valve.

## 5.2 PRESSURE RELIEF VALVES

Since they reseal, pressure relief valves are the preferred relief devices for most all applications except thermal relief. For thermal relief Section 5.5 should be referenced. Inlet connections should be consistent with pipe class and specifications.

Pressure relief valves should be inspected and/or tested on a scheduled basis. The valves should be installed in a manner that ensures there is no obstruction of flow between the pressure relief valve and the piping system or vessel it is intended to protect. The pressure relief valve vent system should be adequately sized and piped such that the discharge is unrestricted and is exhausted to a safe location (See CI Pamphlets 5, 86 and 89 (13.1)).

Rupture discs or breaking-pin assemblies may be installed under pressure relief valves where it is appropriate to protect the valve from corrosion. Where it is necessary to satisfy the ASME Code, a pressure gauge or other suitable telltale indicator must be installed between the rupture disc and the pressure relief valve, and checked for proper operation on a regular basis. Pressure in this section of piping may indicate premature failure or pinholes in the rupture discs.

Types of pressure relief valves include:

### 5.2.1 Conventional

Generally, these have conventional angle body with closed bonnet and a cap over the spring adjusting nut. However, a unique, straight-through design valve (Style JQU) developed for the transportation industry has been adopted for use on stationary equipment (5.4).

Materials of construction typically used in Class I and IV services are:

- body: carbon steel
- trim: Hastelloy C or C 276 (UNS N10002 or UNS N10276) or Monel alloy 400 and R405 (UNS N04400 and UNS N04405)
- spring: carbon steel

Materials of construction for other classes should be consistent with piping specifications.

The design should be consistent and compatible with expected operating temperatures and pressures. Consideration should be given when relieving liquid chlorine and the potential for flashing and low temperatures.

### 5.2.2 Soft-seat

These valves employ a captured plastic insert that is either statically compressed by the metal seats or dynamically loaded between them by the inlet-side pressure to affect optimum seat sealing both prior to opening and upon reseating. The insert usually is an elastomeric O-ring (Viton or Kalrez rubber for chlorine), with a few of the static sealing designs employing PTFE.

Soft-seated construction, particularly in conjunction with a bellows-sealed valve, may negate the need to provide an inlet-side rupture disc or breaking-pin assembly.

### 5.2.3 Bellows

These pressure relief valves employ a convoluted bellows that isolates the stem-guiding surfaces and valve spring from the flowing fluids (or other foreign materials that may be encountered in the discharge piping) that could contact and accelerate corrosion of these vulnerable parts and render the valve inoperable. The bellows usually is constructed of minimum 2-ply Monel alloys 400 and R405 (UNS N04400 and UNS N04405) metal for chlorine service. However, Hastelloy C and C 276 (UNS N10002 and UNS N10276) may be a more prudent choice if the discharge system is likely to be humid from water intrusion.

### 5.2.4 Balanced

A balanced-area design valve permits use where high or variable back pressures (equal to or less than 50% of the set pressure) may be encountered. The ASME Code permits the installation of a rupture disc on the outlet of a balanced-area, bellows-sealed pressure relief valve. The burst rating of the rupture disc employed in this manner should not exceed 50% of the valve set pressure.

## 5.3 LIQUID KNOCKOUT POTS

A knockout pot or drip leg is useful for the protection of gaseous chlorine systems from damage or process upsets that may result from the entry of liquid chlorine.

Conditions under which liquid may be expected are:

- on start-up, after any period of no flow in a chlorine line
- during periods of low flow and/or cold weather
- in operation at a temperature and pressure which approach saturation (refer to Vapor Pressure of Liquid Chlorine curve in CI Pamphlet 1 (13.1))
- in vaporizing systems (CI Pamphlet 9 (13.1))

Minimum requirements for knockout pot installations are:

- Materials of construction and specifications should be consistent, as outlined in this pamphlet, with expected operating temperatures and pressures.
- A liquid knockout pot should be sized for maximum gas flow.
- The pot is to have minimum liquid retention before alarm or notification of liquid presence in the pot.
- Insulation should be considered for all above-ground chlorine lines and pots unless operating pressure is low enough to prevent condensation.
- Block valves may be installed on the inlet and outlet of the knockout pot. Automatic valves should be considered depending on the impact of liquid

chlorine on the process and equipment. The block valve installation should include provisions for periodic testing; a bypass with valve may be useful. Where block valves are used, provision should be made for overpressure protection.

- The system should contain a controlled heat source or pressure reducing equipment for vaporizing any accumulated liquid chlorine. The heat source must be controlled to avoid accelerated corrosion and spontaneous ignition of iron and chlorine at elevated temperatures (CI Pamphlet 1 (13.1)).
- Nitrogen trichloride can accumulate in the knockout pot due to long-term vaporizing of liquid chlorine if the chlorine has trace amounts of nitrogen trichloride. Periodic service of these knockout pots should be planned including evacuation, cleaning and drying. Reference CI Pamphlet 152 (13.1) for additional information.

#### 5.4 TRANSPORTATION VALVES ON STATIONARY EQUIPMENT

In general, other types of valves are preferable to transportation valves for use in stationary piping systems.

##### 5.4.1 Standard Transportation Pressure Relief Valves

These valves with breaking-pin or rupture disc assemblies have been used in chlorine piping and storage systems. The valves are approved for bulk chlorine transports and are not ASME certified. However the valve can be specified and purchased to meet ASME certification.

Consideration of local emission standards in relieving to the atmosphere is recommended.

**CAUTION:** These valves are not designed to function properly if there is back pressure.

##### 5.4.2 Excess Flow Valves

Excess flow check valves are suitable for stationary piping systems. However, it should be noted that these valves must be installed in a vertical position to operate properly. Also, these are high-pressure drop-valves and, as such, may not function well as emergency shutoff valves. Their performance is highly dependent upon flows and downstream pressure drop considerations (CI Drawings 101, 106, 114, and 162).

#### 5.5 LIQUID EXPANSION CHAMBERS

Liquid chlorine has a very high coefficient of thermal expansion. If liquid chlorine is trapped between two valves, the pressure of the blocked-in section will increase as the line temperature increases. The pressure can rise beyond the pressure rating of the line with the potential to cause a connection leak or line failure.

To prevent this failure an expansion bottle should be considered anywhere liquid chlorine could be trapped. Procedures (such as warning tags or locks on valves) are sometimes used to ensure small pipe sections are always open to an expansion bottle. The gas in the expansion chamber is compressed as the pressure in the line increases and protects the line from experiencing the extremely high pressure that can be caused

by liquid-full hydraulic expansion. Recommended configurations and use conditions for expansion chambers are referenced in CI Drawing 136.

The connection should be off the top of the pipe at the high point of the section being protected. For type A installation the first chamber should be elevated above the section being protected to prevent liquid chlorine gravity filling the bottle. The rupture disc on Type A installations should be located close to the first bottle. Location and elevation of the secondary bottle is not critical to the function of the device. For Type B installations the rupture disc should be located as close to the header as possible. Location and elevation of the chamber is not critical to the function of the device.

## 5.6 CHECK VALVES

Check valves (spring-loaded or gravity-operated) are not recommended for chlorine service in situations where total isolation or total elimination of reverse flow is desired. In these cases, automatically operated control valves with appropriate instrumentation are recommended.

Check valves may be useful in chlorine service in applications such as pump headers, where a small amount of reverse flow is acceptable. These check valves should be constructed of materials consistent with piping and valve specifications.

Suitable materials of construction are:

body:	carbon steel or alloy steel per service condition, ductile iron for Class I
body liner (optional):	PFA, PTFE, ETFE, ECTFE, PDVF or equally lined carbon steel or alloy steel
disc, metal seal, and trim:	Alloy 20 or Monel alloys 400 and R405 (UNS N04400 and UNS N04405) and Hastelloy C-276 (UNS N10276)
spring (if used):	Inconel alloy 600 (UNS N06600)

## 5.7 EXPANSION JOINTS

Expansion joints should be restricted to Class I gas service only.

All attempts should be made to design chlorine piping systems with sufficient flexibility to prevent failure of the piping system due to thermal expansion or contraction without the use of expansion joints. When flexibility cannot be introduced into the system through pipe design and/or routing, bellows expansion joints can be employed to absorb the differential expansion while containing the system pressure.

These joints are engineered products which should not be purchased and used as commodity items. Expansion joints shall be kept to a minimum, but when required shall be metallic with a minimum bellows metallurgy of Hastelloy C and C-276 (UNS 10002 and N10276) or Monel alloys 400 and R405 (UNS N04400 and N04405) and shall comply with ASME B31.3 (13.2.8). Periodic maintenance is recommended.

## 5.8 HOSES

Neither metallic nor non-metallic hoses are normally used in permanent piping systems and are not recommended for permanent piping connections. Refer to Section 8 and Appendix A for transportation connections.

## 6. INSTRUMENTATION

Chlorine piping systems should be properly controlled and protected against overpressure, overheating, overfilling, etc., by installing dependable instrumentation. This instrumentation may be pressure, temperature, level, or flow type, and may use indicating, regulating, recording, or alarm devices. Refer to CI Pamphlet 165 (13.1) for recommendations on instrumentation to be used in chlorine applications.

## 7. NONFERROUS METAL TUBING SYSTEMS

Nonferrous metal piping or tubing is generally used for flexible instrument or nonpermanent connections. Aluminum, titanium, and tin must not be used because chlorine reacts with these materials at ordinary temperatures. Where flexible connections are required between transportation containers and rigid piping systems, copper and copper alloy construction may be used.

Because of the reaction between chlorine and tin, no tin should be used in brazing alloys for flexible connection fittings. Therefore, silver brazing alloys must contain no tin and should contain at least 44% silver. Note: Tin content equal to or less than 0.01% is in the range that many ASTM specifications consider "analytical error" so a tin free solder might contain that much tin and still be within specification and is considered acceptable for chlorine service. In situations requiring protection against external corrosion, protective coatings such as cadmium or zinc plating are recommended. Hydrogen embrittlement is not a typical failure mechanism for non-ferrous metals. Tubing components should be limited to a single manufacturer since connectors are not compatible between manufacturers.

Table 7-1 identifies some commonly used nonferrous metals and special alloys. Consideration should be given to the mechanical protection of tubing systems from external damage.

<b>Table 7-1. Nonferrous Metal Tubing Systems</b>					
<b>Item</b>	<b>Material [See Note 4]</b>	<b>Fluid State</b>	<b>Type</b>	<b>Comments</b>	<b>Common Use [See Note 5]</b>
Tubing	Copper [See Note 1]	Gas or Liquid	ASTM B88	Seamless, Type K or heavier, annealed	Container connections
	Monel [See Note 3]	Gas or Liquid	ASTM B165	Cold-drawn, annealed	Instrument connections, container connections

<b>Table 7-1. Nonferrous Metal Tubing Systems (Cont'd.)</b>					
Fittings	Monel [See Note 3]	Gas or Liquid	ASTM B165	--	Instrument connections
	Copper	Gas or Liquid	ASTM B75	Solder Type [See Note 6]	Container connections [See Note 2]
Adapters/ Adapter Nuts	Aluminum-Silicon-Bronze (Alloy B)	Gas or Liquid	ASTM B124, B150 UNS C64210	[See CI Drawing 130]	Interface connections, container connections
	Leaded Commercial Bronze	Gas or Liquid	ASTM B140 UNS C31400	--	Interface connections, container connections, piping
Note 1	An external coating (e.g. cadmium or zinc plating) is recommended in situations requiring additional corrosion resistance. Hydrogen embrittlement is not a typical failure mechanism for nonferrous metals.				
Note 2	Gasketed-type fittings are preferred where connections are disconnected and reconnected frequently. Flared type fittings are not recommended.				
Note 3	Instrument tubing of ¼ - to ½-inch (6.35 to 12.7 mm) OD shall be ASTM B165 Monel alloy annealed, seamless tubing with a .035-inch (0.89-mm) wall minimum, to be used with ASTM B165 Monel alloy (UNS N04400 and N04405) ferrule-type tubing fittings.				
Note 4	Other alloys may be used based on specific experience such as Alloy 20 and Hastelloy C-276.				
Note 5	For periodic disconnect/reconnect connections, such as container applications, the yoke and adaptor (CGA Connection 820 or 820C) is recommended. For connections between tubing and stationary piping, a union nut connection (such as CGA Connection 660) is acceptable.				
Note 6	Silver brazing alloys must contain no tin and should contain at least 44% silver.				

**8. TRANSPORTATION CONTAINER CONNECTIONS**

Connectors and fittings to permit unloading chlorine transportation containers are, in general, considered nonpermanent installations. These connectors and fittings are identified below in Table 8-1 and some of their uses are cited. Details on each item can be found in the indicated drawings. Non-permanent installations should use yoke-type or flanged connections since threads that are used repeatedly and exposed to a chlorine atmosphere may fail prematurely. Two bolt flanges are often used on unloading loops (CI Drawing 118). Care must be taken to apply the gasket loading forces uniformly by tightening both bolts evenly.

The information in Table 8-1 is generally for liquid or gas service between -20°F and 150°F (-29°C and 66°C) and from vacuum to 300 psig. Some components, notably transfer hoses, are rated for higher pressure.

<b>Table 8-1. Connectors to Transportation Containers Guide</b>			
<b>Item</b>	<b>Fluid State</b>	<b>Comments</b>	<b>Common Use</b>
Tank Car Unloading Connection	Gas or Liquid	Unloading loops [See CI Drawing 118]	Connects permanent piping system with barge, truck or railcar
Chlorine Transfer Hose	Gas or Liquid	Metallic reinforced and special non-metallic with protection [See Appendix A]	Transfer hose is more flexible than tank car unloading connector and may be more adaptable for special needs
Small Union Connection	Gas or Liquid	[See CI Drawing 171]	Connect flexible connectors to auxiliary cylinder valves or manifolds
Cylinder Valve Adapter	Gas or Liquid	Brass or Alloy "B" [See CI Drawings 112, 130 and 189] Lead commercial bronze ASTM B140	Connects valves to flexible connectors
Cylinder Valve Yoke	Gas or Liquid	[See CI Drawings 131 and 189]	Yokes may be used for non-permanent connections to cylinders, ton containers or piping systems with cylinder valves
Header Valve	Gas	[See CI Drawings 113 and 112 for material specifications]	Used on gas pressure headers to permit connection to flexible copper tubing (does not require fusible plugs)
Gasket [See Note 1]	Gas or Liquid	[See CI Pamphlet 95 (13.1)]	Gasket replacement is recommended after each disconnect
Note 1	Joint design is a critical factor in selection of gasket material and should be limited to a confined joint, such as tongue and groove.		

## 9. PLASTIC MATERIALS OF CONSTRUCTION

For purposes of this section, "plastic piping systems" refers to fabrications other than valves where plastic is used as a liner.

Because relatively inexpensive, high strength metals can be used successfully in dry chlorine service, plastics are rarely used as piping materials to handle chlorine under pressure. On the other hand, in wet chlorine service (e.g. cell gas, chlorinated water, vent collection systems, etc.), or in vacuum service (dry or wet), where most metals are subject to rapid corrosion, and where pressures are relatively low, plastic piping systems can be used very successfully. In like manner, if conduits are used to protect plastic piping or tubing, the permeated gas will accumulate within the conduit even if the gas flow is under a vacuum. Positive air purging can be employed to keep the gas from accumulating to high levels within the conduit. Be sure to vent the conduit to a safe area.

When specifying plastic materials it is critical to not only specify the plastic type (PVC, CPVC, PP, etc.) but specify the manufacturer and the manufacturers grade (if



applicable) of the plastic. In many cases plastic materials vary between manufacturers due to formulations or production and even the same manufacturer may have different grades of the same plastic. As an example, there are dozens of different types and grades of CPVC on the market.

Plastics are also used extensively as lining materials for metallic piping components and valves. The plastic protects the metal from corrosion and the metal protects the plastic from external forces and enables the system to operate at higher pressures than would be possible with an all plastic component.

Since plastics can offer good resistance to wet chlorine, when properly specified and used, plastic piping systems offer many benefits. However, they do have limitations that must be taken into account. These include:

- Many plastics (generally those that are not fluorinated or chlorinated to a high degree) will react with chlorine and may fail rapidly and catastrophically as a result.
- Many plastic piping materials have limited pressure retaining capabilities and are subject to rapid degradation of structural properties (strength) with increasing temperature. Use should therefore be limited to temperatures well below those at which the physical properties of the plastic are reduced to the point where the pressure rating of the pipe does not have an adequate margin of safety.
- Since plastic piping materials have reduced structural properties as compared to metallic piping systems, added care should be exercised in the design of pipe support systems to prevent sagging and/or collapse especially in smaller pipe sizes.
- Many plastics are subject to degradation on exposure to UV light. Additives and coatings should therefore be employed to minimize the effect and exposure to UV light. Chlorine has the ability to permeate through the microstructure of many plastics. When using plastics that exhibit this phenomenon, precautions must be employed to account for the permeation (e.g. the need for vents should be considered on piping lined with plastic materials, proper precautions should be taken when using such plastics in poorly ventilated areas, etc.)
- Because many solid plastic piping systems (Solid plastic meaning that the entire piping component is plastic, as opposed to lined piping) can shatter when they are overpressurized, they are not recommended for use in pressurized chlorine gas service (e.g. PVC, CPVC, PVDF, ABS, others). Pressure in gas service should be limited to 6 PSIG when using plastic materials that are prone to this type of failure. Gas service at pressures higher than 6 PSIG should be considered only after a thorough evaluation of the piping system.
- Liquid chlorine is usually handled at high pressure or low temperature and it has physical properties (high specific gravity, high coefficient of expansion) that could damage plastic components. Therefore, solid plastic piping systems should not be used to handle liquid chlorine.

- Plastics are subject to damage by external forces. Plastic piping systems should therefore be well supported and should be protected from impact.
- Plastic tubing is sometimes used to transfer small quantities of chlorine for sampling, instrument inputs, etc. When using tubing, care should be taken to provide generous radii of curvature, to protect the tubing from physical damage and to avoid contact with hot surfaces. Tubing should be heavy wall, limited to ½ inch maximum OD. Use with appropriate fluoropolymer tubing fittings.
- Plastic Lined piping systems may be subject to external corrosion. In such cases, care should be taken to protect the pipe with suitable coatings and frequent maintenance.

Typical limitations on the use of plastics in chlorine service are shown in Tables 9-1 and 9-2.

<b>Table 9-1. Plastics in Gas or Liquid Chlorine Service Piping Systems (Note 3)</b>				
<b>Plastic</b>	<b>Abbreviation</b>	<b>Pressure</b>	<b>Maximum Temperature</b>	<b>Common Uses</b>
Polytetrafluoroethylene (ASTM D1457)	PTFE	[See Note 6]	400°F (204°C) limit on plastic	Transfer hose, instrument tubing, valve parts, pipe and fitting liners, gaskets and packing
Perfluoroalkoxy (ASTM D3307)	PFA	[See Note 6]	400°F (204°C) limit on plastic	Valve parts, pipe and fitting liners
Fluorinated Ethylene Propylene	FEP	[See Note 6]	300°F (149°C) limit on plastic	Valve parts, pipe and fitting liners
Polyvinylidene difluoride (ASTM D3222)	PVDF	[See Note 6]	280°F (138°C)	Pipe [See Note 4], valve parts, tube fittings, pipe and fitting liners
Ethylene chlorotrifluoroethylene (ASTM D3275)	ECTFE	[See Note 6]	300°F (149°C)	Valve parts, pipe and fitting liners
Ethylene tetrafluoroethylene	ETFE	[See Note 6]	300°F (149°C)	Valve parts, pipe and fitting liners

<b>Table 9-2. Plastics in Gas Only Chlorine Service Piping Systems</b>				
<b>Plastic</b>	<b>Abbreviation</b>	<b>Pressure</b>	<b>Maximum Temperature</b>	<b>Common Uses</b>
Polyvinyl chloride (ASTM D1784)	PVC	[See Note 5]	130°F (54°C)	Pipe [See Note 2], pipe fittings, tube fittings, valve parts
Chlorinated Polyvinyl chloride (ASTM D1784)	CPVC	[See Note 5]	212°F (100°C)	Pipe [See Note 2], pipe fittings, valve parts
Acrylonitrile butadiene styrene (ASTM D3965)	ABS	[See Note 5]	150°F (66°C)	Pipe [See Note 2], pipe fittings, tube fittings, valve parts

<b>Table 9-2. Plastics in Gas Only Chlorine Service Piping Systems (Cont'd.)</b>				
<b>Plastic</b>	<b>Abbreviation</b>	<b>Pressure</b>	<b>Maximum Temperature</b>	<b>Common Uses</b>
Fiberglass-reinforced polyester [See Note 1]	FRP	[See Note 5]	212°F (100°C)	Chlorine cell covers, duct work
Polyethylene (ASTM D3350)	PE	[See Note 5]	130°F (54°C)	Tubing, valve parts
Polypropylene	PP	[See Note 5]	130°F (54°C)	Tube fittings, valve parts
Note 1	Resin must be specifically selected for chlorine service.			
Note 2	Schedule 80 with screwed joints. May be schedule 40 with solvent cemented socket joints.			
Note 3	Do not use solid plastic pipe in liquid chlorine service.			
Note 4	Schedule 80 with screwed joints. May be schedule 40 with thermally fused socket joints.			
Note 5	Limited to from full vacuum to 6 psig (41 kPa) maximum in solid plastic pipe. For lined pipe, see note 6.			
Note 6	Consult manufacturer of piping component for temperature/pressure limitations.			

## 10. PIPING LAYOUT DESIGN CONSIDERATIONS

Good piping layout will enhance safety, reduce maintenance costs, and provide efficient operations at effective costs. The following are several important considerations in designing piping layout.

- Pipe sizing should be engineered to minimize the possibility of corrosion/erosion that may be caused by high fluid velocities. Particular attention should be paid to sections of the system where local velocities can be excessive such as downstream of valves, bends, pump discharge lines and orifice plates. However, with proper design, high velocities have been employed successfully in many cases.
- Avoid trapping liquid chlorine between closed valves and/or provide expansion chambers (see CI Drawing 136) or pressure relief. Although the intent is to reduce risk, in some cases, small expansion bottles can increase the risk of leaks because they add complexity and are themselves subject to failure. Therefore, expansion bottles may be omitted if all the following apply:
  - All block valves needed to trap a section of piping are within close proximity (arm's length).
  - Operating procedures, administrative controls, and/or system designs are used to avoid trapping chlorine.
  - Owner risk analysis accounts for the volume of the chlorine contained in the section, consequences of a component failure, the probability of trapping to occur, and the preventive safeguards.

- Consider a layout of piping to facilitate future clean-out operations. Arrange and support piping to permit removal of process equipment and components.
- Avoid installing chlorine lines next to steam lines, acid lines, etc., that could cause corrosion of the chlorine line. Protect chlorine piping from potential sources of excessive heat or fire.
- The use of vent and drain branches in a chlorine pipeline should be limited to the minimum necessary for the removal of dirt, liquid or gas. However, all sections that can be blocked in should have sufficient connections for clearing the chlorine.
- Provide for linear thermal expansion, preferably by pipe loops. Bellows-type expansion joints should be avoided.
- In addition to piping design, operational procedures should be incorporated to minimize the possibility of liquid hammer.
- Chlorine lines should be readily identifiable.

#### 10.1 CLEARANCES

Road and walkway clearances should be set to minimize the potential for impact damages. Barriers or guardrails should be considered. Railroad and roadway clearances may be regulated by federal, state, provincial or local laws. If chlorine piping must pass through a wall or bulkhead, proper side clearances must be maintained.

#### 10.2 SUPPORTS

Piping should be adequately supported to prevent sagging and resting on structural steel. Do not hang other piping from chlorine lines and, conversely, do not hang chlorine lines from other piping. Piping should be supported with hangers or pipe shoes that do not allow metal to metal wear or corrosion. If located in an area where seismic activity can be significant, review local code requirements to determine if special design considerations are necessary.

#### 10.3 ROUTING

Chlorine piping should be routed the shortest distance practical with consideration given to flexibility, line expansion and good engineering practice. Changes in elevation should be minimized. This pamphlet considers aboveground installations only. If the piping system is buried underground or crosses waterways, then refer to CI Pamphlet 60 (13.1), which contains special requirements for underground protection, etc.

#### 10.4 VALVING

It is important all valves and controls be located in accessible areas. Control valves and relief valves should be located where they can be serviced conveniently.

Block valves must be located as close to equipment as possible, preferably on the nozzle.

Block valves should be located in branch lines at the main header and, where practical, located to allow lines to drain away from the valves.

#### 10.5 HYDRAULIC THERMAL EXPANSION DESIGN CONSIDERATIONS

Liquid chlorine has a high coefficient of thermal expansion. Relatively small increases in liquid chlorine temperature can create enough pressure to cause a blocked-in section of piping to rupture or leak at the connections.

The need for liquid expansion chambers, as shown on CI Drawing 136, should be evaluated if liquid chlorine can be trapped between two closed valves. For small trapped volumes, such as around control valves, administrative draining procedure may be preferable to the installation of a small expansion chamber. These expansion chambers should be adequately supported and located in an accessible area for routine inspection and maintenance.

#### 10.6 DESIGN CONSIDERATIONS TO PREVENT CONDENSATION

Condensation or reliquification can occur in gas lines when the temperature drops below the pressure-temperature equilibrium. To prevent gas condensation, heat tracing and insulation, or the use of a pressure reducing valve is recommended. Any heat tracing installation should be designed such that the surface temperature of the pipe shall not exceed 300°F (149°C) to eliminate the possibility of chlorine-steel reaction which occurs near 483°F (251°C), see CI Pamphlet 1 (13.1).

#### 10.7 VAPORIZATION

Vaporization or flashing can occur in liquid lines due to pressure drop, elevation change, or temperature increase. System design should assure that chlorine remains in its intended state under all operating conditions.

#### 10.8 INSULATION

Chlorine pipelines (liquid and gaseous) often operate at pressures and temperatures that cause condensation and ice formation on the outside of the lines. For this reason, the insulation must provide a sufficient moisture barrier to prevent corrosion under the insulation. A water-resistant insulating material such as cellular glass, urethane or foam rubber should be used. Engineered access methods which do not compromise the system moisture barrier may be used to accommodate thickness testing or exterior inspection.

#### 10.9 PAINTING

Protective coating on the pipe should be considered to limit external corrosion.

### 11. **PREPARATION FOR USE**

#### 11.1 CLEANING

All portions of new chlorine systems must be cleaned and dried prior to use. Because chlorine can react violently with organic compounds (oil, grease, solvents, alcohols,

hydrocarbons, and other foreign materials) and water, cleaning procedures must emphasize the complete removal all residues and thorough drying before use.

There are several cleaning techniques available, but there is no best method. The appropriate technique will depend on the nature of the system and the type of contamination. For any technique employed, the user must establish a written procedure. Each step of the cleaning procedure should be closely monitored. The procedure should include criteria for written acceptance of the effectiveness of the cleaning. Reference material for developing procedures can be found in CGA's Pamphlet G-4.1 (13.4.5).

Procedures should be in compliance with all federal, state and local regulations. The recommendations of the manufacturers of the cleaning product and the equipment to be cleaned should be followed as applicable.

Three common methods used to clean chlorine systems are described below. Sometimes, a combination of methods is most useful in a given situation. Particular attention must be paid to joint areas where cleaning solutions could collect. Consideration should be given to valve removal prior to cleaning operations or hydrostatic tests and gasket replacement after cleaning.

#### 11.1.1 Aqueous Cleaning

Aqueous methods are used for both new construction and plant maintenance, particularly for equipment already exposed to chlorine service. Examples include detergents, surfactants, coalescing agents and inorganic solutions. Use of these materials must be followed by thorough flushing with water to remove residues. Steam is often used to purge the pipe and raise the temperature to aid in drying. Care must be taken to ensure the system is properly dried.

#### 11.1.2 Abrasive Cleaning

This method is used primarily on large piping sections for new construction. Types of abrasives include sand, dry ice, steel shot, garnet, corn husks, etc. Care must be taken to isolate valves, instruments, and process equipment from potential damage. All blasting residue must be removed from pipe sections prior to installation. If care is taken to exclude moisture, the assembled system will be ready for dry air or nitrogen drying.

#### 11.1.3 Solvent Cleaning

Solvents are most often used for cleaning individual components (e.g. valves, relief valves, and instruments), especially parts that can be cleaned in commercial vapor degreasing equipment. For large chlorine systems, this method is not normally used due to the need for addressing environmental and industrial hygiene risks. Many solvents are excellent cleaning agents but pose significant risks due to toxicity, flammability and/or reactivity with chlorine. The best overall solvent must be available as a liquid in convenient containers, minimally reactive with chlorine, be nonflammable, have relatively low vapor pressure, have a low toxicity rating and be capable of removing the contamination. Although most solvents do not meet all of the above criteria, the user must prioritize these criteria and select the best solvent for the application. The user should strive to avoid solvents that are proven or suspected human carcinogens.

There is no known, universally acceptable, solvent. However, new water based, non-toxic, biodegradable solvents are available and continue to be developed. Some are suitable for cleaning chlorine equipment in specific applications. Any solvent usage requires personnel safeguards, good work practices, suitable collection, and safe, environmentally acceptable disposal of residual materials.

#### 11.1.4 Standards of Cleanliness

Potential contaminants include oils and grease and particulate matter. Some method must be used for evaluating the effectiveness of the cleaning process.

Where practical, an initial visual inspection should be done to look for gross contamination. For solvent and water washes discoloration or visible particles in the spent liquid may indicate contamination.

Parts that have high surface area and that do not dissipate heat, such as metal packing or mesh pads, require special scrutiny. Extra care should be taken to ensure such parts are adequately cleaned and free of residue. Special precautions should be taken and consideration should be given to ensure that there is no surface contamination. This may be accomplished with black lights, laboratory analysis, or other suitable techniques. Black lights cause some oils to fluoresce and thus can be effective at identifying residual oil films; however, since some oils do not fluoresce, caution should be used when applying this technique.

Inspections should be done before and after assembly. An example is inspection of pipe components and spool pieces followed by inspection of the completed piping system.

## 11.2 PRESSURE TESTING

All new or modified chlorine piping systems must undergo pressure testing. ASME B31.3, Process Piping testing requirements, should be applied as a minimum standard. There are three types of acceptable testing methods: hydrostatic testing, pneumatic testing, and the alternate test method. Minor repairs and additions made after the piping system is initially tested may have the retest waived by the owner when precautionary measures are taken to assure sound construction. When it is not considered practical to isolate a piping system from a vessel, the piping may be tested with the vessel at the owner's option provided the pressure is not less than 77% of the original piping test pressure.

### 11.2.1 Hydrostatic Testing

New chlorine piping should be hydrostatically tested to one and a half (1½) times the maximum pressure to which the system may be subjected. Pressure gauges, relief valves, automatic control valves, and other components which may be damaged should be removed and openings should be blocked off prior to testing. After testing, all moisture-absorbing gaskets and valve packing should be replaced. It is essential that chlorine systems be thoroughly dried prior to being put into service. There are some circumstances under which drying cannot be accomplished after hydrostatic testing with water. For situations where hydrostatic testing is undesirable, the pneumatic or alternate testing methods may be used.

### 11.2.2 Pneumatic Testing

Pneumatic testing involves the hazard of released energy stored in compressed gas. The test pressure should be 110% of design pressure. The pressure should be increased until a gauge pressure which is the lesser of one half the test pressure or 25 psig is attained, at which time a preliminary leak check should be made. The pressure should be gradually increased and leak check made at intermediate pressures.

Extreme care must be used when pneumatic testing is conducted. There are numerous **industry examples of high pressure pneumatic testing that resulted in the loss of life and significant destruction. For high pressure testing, the hydrostatic testing method should be used if possible.**

### 11.2.3 Alternate Testing Method

As an alternative to pressure testing, weld examination techniques may be used. Circumferential, longitudinal, and spiral groove welds shall be 100% radiographed. All other welds shall be tested using the liquid penetrant method or the mag particle method. Additionally, the piping system must undergo flexibility analysis and sensitive leak test. The sensitive leak test is described in the ASME Boiler and Pressure Vessel Code - Section V, Article 10 and involves checking for leaks of a gas such as helium.

## 11.3 DRYING

Chlorine piping systems must always be dried before being placed in service. Even if water has not been purposely introduced into the system for hydrostatic testing or cleaning, drying is required because moisture may enter the system from the atmosphere or other sources. Where steam has been used for cleaning, the steaming should be followed by the introduction of a dry nitrogen or dry air purge. As a precautionary measure, the user should identify and provide safeguards to prevent the collapse/implosion of piping systems not rated for vacuum service or provided with vacuum relief should cold purge gas be introduced into a system previously heated with steam.

Heating the purge gas will aid considerably in the drying process. The temperature should be limited based on the equipment and insulation type, but 200°F (93°C) is typically an acceptable temperature. The purge gas flow should be started at high volume rates to sweep the moisture out of the piping system, and then reduced. The system should be dried until all the vent gas streams leaving have a -40°F (-40°C) dew point, measured at normal system operating pressure, or reasonably close to the entering purge gas dew point. The purge rates should be at an absolute minimum, allowing adequate time for the purge gas to reach equilibrium when the dew point is taken.

Drying using ambient-temperature dry air or nitrogen purge may take an extended period of time. This time can be decreased and the effectiveness increased by the use of a pressure cycling technique. Consideration can be given to using the services of commercial system dehydrators. These vendors normally dry piping and equipment by circulating or purging with large volumes of heated nitrogen.



### 11.3.1 Valves

Valves require special attention. Consideration should be given to valve removal for disassembly and drying if water has entered the piping system. Most valves, regardless of style, have pockets where water can be trapped, especially if the valve is fully open. Valves left in the piping system must be fixed in the half-open position when the system is being dried. Valves removed temporarily from the system during the drying operation must also be checked to ensure that water or moisture is not trapped in a cavity. These valves must be dried thoroughly prior to replacement in the piping system if they are not dried with the rest of the system. Personnel responsible for drying the system should be familiar with valve construction and aware of places where water or moisture can be trapped.

### 11.4 TESTING FOR LEAKS

Leak testing should be done once the piping system is completely assembled. The purpose of a leak test is to ensure all connections and components will not leak chlorine when pressurized. Leak testing is not a substitute for pressure testing. If the system was not disassembled and reassembled as part of the pressure testing and drying process, the nitrogen/dry air test (i.e. Step 1) may be omitted.

#### Step 1

Pressure the system to the lower of 150 psig (1034 kPA) or to the normal operating pressure with dry air or nitrogen. Use a soap solution to test for leaks at joints.

#### Step 2

Introduce chlorine gas (never liquid chlorine) into the system and raise the pressure to approximately 5 psig.

#### Step 3

Test the system for leaks with aqua ammonia. Care must be taken that chlorine has diffused throughout the piping system before leak checking with ammonia.

The reaction of ammonia vapor with escaping chlorine forms a dense white cloud. The most convenient way to use ammonia for this purpose is to direct the vapor from a plastic squeeze bottle containing 26 degree Baumé aqua ammonia solution at the suspected leak. Do not squirt liquid aqua ammonia on pipe fittings.

Never attempt to repair leaks by welding until all chlorine has been purged from the system. When detectable leaks have been repaired, the line should be retested by repeating Step 3.

Any effort to detect the source of a leak should be carried out with full consideration for potential hazards. Appropriate protective equipment must be used.

#### Step 4

Slowly increase the chlorine pressure and continue to check for leaks at several intermediate pressures until the operating pressure is obtained. If leaks are detected repairs should be made and step 4 continued until the operating pressure is achieved.

## 12. ROUTINE AND PERIODIC INSPECTION AND MAINTENANCE

### 12.1 ROUTINE MAINTENANCE

Written procedures specific to chlorine piping maintenance are required according to OSHA regulations (29 CFR 1910.119 (13.4.2)) and should be used to ensure long-term integrity of the system. CI Pamphlet 85 (13.1) summarizes key considerations for an effective piping system mechanical integrity program. This reference should be used when developing a new Mechanical Integrity Program for piping systems or used to review an existing program for completeness.

Personnel that work on chlorine piping systems should be trained in the proper maintenance procedures. After any routine maintenance, the affected area of piping should be prepared for return to service as per Section 11 of this pamphlet.

### 12.2 PREVENTATIVE MAINTENANCE

As part of a good overall preventative maintenance program, consideration should be given to ensuring that the following items are checked periodically and corrected as needed:

- flange bolt condition and tightness
- valve packing leaks
- valve operation
- insulation condition
- paint condition
- condition of supports

Consideration should be given to repainting on a regular basis, with timing determined by individual site conditions. This will maximize pipe life and minimize leaks by minimizing external corrosion.

#### 12.2.1 Periodic Inspections

Chlorine piping systems should be inspected on a regular basis. The inspections will help to find problems prior to failure. Criteria for initiating replacement or repair should be developed for each facility. There are multiple ways to inspect chlorine piping systems. Useful methods include visual inspections, ultrasonic thickness checks and non-destructive radiography checks. A thorough visual inspection is an important activity that can be done by trained operating personnel as well as by qualified inspectors. Other methods can be used as a supplement. The results of all inspections should be documented.

#### 12.2.2 Visual

A visual inspection should include a leak check of all flanges, valves and other fittings and attachments. The slightest smell of chlorine should initiate a thorough investigation to find and repair the leak. Particular areas of concern should include such things as

---

pipe supports and areas with paint or insulation damage. Where insulation is damaged further inspection is warranted. Special note should be taken of weld areas, as these areas corrode most quickly. Any significant observed pitting or wall loss should be investigated further, and should be corrected as necessary.

### 12.2.3 Non-Destructive Testing

Non-destructive testing methods detect pipe wall thickness, pit depths and internal and external erosion/corrosion. These methods include ultrasonic thickness measurements and radiographic measurements.

Due to normal variations in pipe dimensions, it is important that the same points be measured each time they are tested. This can be accomplished by developing "maps" or orthographic sketches of the system, with test points clearly identified and marked. Routine testing will show the corrosion rates typical for the system, so that the timing of major repairs can be estimated. Consideration should be given to checking areas of high fluid velocity more frequently due to possible internal erosion.

Radiographic techniques are available to check pipe wall thickness through insulation. This permits checking piping systems without breaking the vapor barrier of the insulation. If test methods are used which require the removal of insulation, care must be taken to restore the insulation vapor barrier integrity.

### 12.2.4 Inspection Records

Written records are an integral part of the process safety OSHA regulations. These records should include the original inspection report, as well as recommended further inspections and corrective actions. Documentation of all follow-up actions should be appended to the original report.

### 13. REFERENCES

The following sections provide detailed bibliographic information on Chlorine Institute publications and other documents.

#### 13.1 CHLORINE INSTITUTE REFERENCES

The following publications are specifically referenced in CI Pamphlet 6. The latest editions of CI publications may be obtained at [www.chlorineinstitute.org](http://www.chlorineinstitute.org).

<b><u>Pamphlet #</u></b>	<b><u>Title</u></b>
1	<i>Chlorine Basics (formerly The Chlorine Manual)</i> , ed. 7; Pamphlet 1; The Chlorine Institute: Arlington, VA, <b>2008</b> .
5	<i>Bulk Storage of Liquid Chlorine</i> , ed. 8; Pamphlet 5; The Chlorine Institute: Arlington, VA, <b>2011</b> .
9	<i>Chlorine Vaporizing Systems</i> , ed. 7; Pamphlet 9; The Chlorine Institute: Arlington, VA, <b>2011</b> .
60	<i>Chlorine Pipelines</i> , ed. 7; Pamphlet 60; The Chlorine Institute: Arlington, VA, <b>2013</b> .
85	<i>Recommendations for Prevention of Personnel Injuries for Chlorine Production and Use Facilities</i> , ed. 5; Pamphlet 85; The Chlorine Institute: Arlington, VA, <b>2010</b> .
86	<i>Recommendations to Chlor-Alkali Manufacturing Facilities for the Prevention of Chlorine Releases</i> , ed. 5; Pamphlet 86; The Chlorine Institute: Arlington, VA, <b>2010</b> .
89	<i>Chlorine Scrubbing Systems</i> , ed. 3-R1; Pamphlet 89; The Chlorine Institute: Arlington, VA, <b>2008</b> .
95	<i>Gaskets for Chlorine Service</i> , ed. 4; Pamphlet 95; The Chlorine Institute: Arlington, VA, <b>2008</b> .
100	<i>Dry Chlorine: Behaviors of Moisture in Chlorine and Analytical Issues</i> , ed. 4; Pamphlet 100; The Chlorine Institute: Arlington, VA, <b>2011</b> .
152	<i>Safe Handling of Chlorine Containing Nitrogen Trichloride</i> , ed. 3; Pamphlet 152; The Chlorine Institute: Arlington, VA, <b>2011</b> .
165	<i>Instrumentation for Chlorine Service</i> , ed. 2; Pamphlet 165; The Chlorine Institute: Arlington, VA, <b>2009</b> .

## 13.2 ASME STANDARDS

The following ASME standards are specifically referenced in Pamphlet 6.

- 13.2.1 *Unified Inch Screw Threads (Un and UNR Thread Form)*, ASME B1.1, an ANSI standard; The American Society of Mechanical Engineers: New York, NY, **2003**.
- 13.2.2 *Pipe Flanges and Flanged Fittings*, ASME B16.5, an ANSI standard; The American Society of Mechanical Engineers: New York, NY, **2009**.
- 13.2.3 *Factory-Made Wrought Steel Buttwelding Fittings*, ASME B16.9, an ANSI standard; The American Society of Mechanical Engineers: New York, NY, **2007**.
- 13.2.4 *Forged Steel Fittings, Socket-Welding and Threaded*, ASME B16.11, an ANSI standard; The American Society of Mechanical Engineers: New York, NY, **2001**.
- 13.2.5 *Valves - Flanged, Threaded and Welding End*, ASME B16.34, an ANSI standard; The American Society of Mechanical Engineers: New York, NY, **2009**.
- 13.2.6 *Square and Hex Bolts and Screws (Inch Series)*, ASME B18.2.1, an ANSI standard; The American Society of Mechanical Engineers: New York, NY, **2010**.
- 13.2.7 *Square and Hex Nuts (Inch Series)*, ASME B18.2.2, an ANSI standard; The American Society of Mechanical Engineers: New York, NY, **2005**.
- 13.2.8 *Process Piping*, ANSI/ASME Code for Pressure Piping; ASME B31.3, an ANSI standard; The American Society of Mechanical Engineers: New York, NY, **2010**.
- 13.2.9 *Welded and Seamless Wrought Steel Pipe*, ASME B36.10M, an ANSI standard; The American Society of Mechanical Engineers: New York, NY, **2004**.
- 13.2.10 *Welding and Brazing Qualifications, Section IX*, ASME Boiler and Pressure Vessel Code; ASME BPVC-IX, an ANSI standard; The American Society of Mechanical Engineers: New York, NY, **2007**.

## 13.3 ASTM STANDARD DESIGNATIONS

The following ASME documents are specifically referenced in Pamphlet 6.

- 13.3.1 *Pipe, Steel, Black and Hot-Dipped, Zinc-Coated Welded and Seamless*, Book of ASTM Standards; A53; American Society of Testing and Materials: West Conshohocken, PA, **2012**.
- 13.3.2 *Carbon Steel Forgings for Piping Applications*, Book of ASTM Standards; A105; American Society of Testing and Materials: West Conshohocken, PA, **2011**.
- 13.3.3 *Seamless Carbon Steel Pipe for High-Temperature Service*, Book of ASTM Standards; A106; American Society of Testing and Materials: West Conshohocken, PA, **2011**.
- 13.3.4 *Carbon Steel Forgings for General Purpose Piping*, Book of ASTM Standards; A181; American Society of Testing and Materials: West Conshohocken, PA, **2011**.

- 13.3.5 *Forged or Rolled Alloy-Steel Pipe Flanges, Forged Fittings, and Valves and Parts for High-Temperature Service*, Book of ASTM Standards; A182; American Society of Testing and Materials: West Conshohocken, PA, **2011**.
- 13.3.6 *Alloy-Steel and Stainless Steel Bolting Materials for High-Temperature Service*, Book of ASTM Standards; A193; American Society of Testing and Materials: West Conshohocken, PA, **2012**.
- 13.3.7 *Carbon and Alloy-Steel Nuts for Bolts for High Pressure and High-Temperature Service*, Book of ASTM Standards; A194; American Society of Testing and Materials: West Conshohocken, PA, **2011**.
- 13.3.8 *Pressure Vessel Plates, Alloy Steel, Nickel*, Book of ASTM Standards; A203; American Society of Testing and Materials: West Conshohocken, PA, **2007**.
- 13.3.9 *Steel Castings, Carbon, Suitable for Fusion Welding for High-Temperature Service*, Book of ASTM Standards; A216; American Society of Testing and Materials: West Conshohocken, PA, **2008**.
- 13.3.10 *Piping Fittings of Wrought Carbon Steel and Alloy Steel for Moderate and Elevated Temperatures*, Book of ASTM Standards; A234; American Society of Testing and Materials: West Conshohocken, PA, **2011**.
- 13.3.11 *Alloys Steel Bolting Materials for Low-Temperature Service*, Book of ASTM Standards; A320; American Society of Testing and Materials: West Conshohocken, PA, **2011**.
- 13.3.12 *Steel Bars, Alloy, Standard Grades*, Book of ASTM Standards; A322; American Society of Testing and Materials: West Conshohocken, PA, **2007**.
- 13.3.13 *Seamless and Welded Steel Pipe for Low-Temperature Service*, Book of ASTM Standards; A333; American Society of Testing and Materials: West Conshohocken, PA, **2011**.
- 13.3.14 *Carbon and Low-Alloy Steel Forgings Requiring Notch Toughness Testing for Piping Components*, Book of ASTM Standards; A350; American Society of Testing and Materials: West Conshohocken, PA, **2012**.
- 13.3.15 *Castings, Austenitic, Austenitic-Ferritic (Duplex) for Pressure Containing Ports*, Book of ASTM Standards; A351; American Society of Testing and Materials: West Conshohocken, PA, **2012**.
- 13.3.16 *Steel Castings, Ferritic and Martensitic, for Pressure-Containing Parts, Suitable for Low-Temperature Service*, Book of ASTM Standards; A352; American Society of Testing and Materials: West Conshohocken, PA, **2012**.
- 13.3.17 *Ferritic Ductile Iron Pressure-Retaining Castings for Use at Elevated Temperatures*, Book of ASTM Standards; A395; American Society of Testing and Materials: West Conshohocken, PA, **2009**.
- 13.3.18 *Piping Fittings of Wrought Carbon Steel and Alloy Steel for Low-Temperature Service*, Book of ASTM Standards; A420; American Society of Testing and Materials: West Conshohocken, PA, **2010**.

- 
- 13.3.19 *Pressure Vessel Plates, Carbon Steel, for Moderate and Lower Temperature Service*, Book of ASTM Standards; A516; American Society of Testing and Materials: West Conshohocken, PA, **2010**.
- 13.3.20 *Electric-Resistance-Welded Low-Carbon Steel Pipe for the Chemical Industry*, Book of ASTM Standards; A587; American Society of Testing and Materials: West Conshohocken, PA, **2005**.
- 13.3.21 *Pressure Vessel Plates, Carbon Steel, High Strength, for Moderate and Lower Temperature Service*, Book of ASTM Standards; A612; American Society of Testing and Materials: West Conshohocken, PA, **2007**.
- 13.3.22 *Castings, Iron-Chromium-Nickel Corrosion-Resistant for Severe Service*, Book of ASTM Standards; A744; American Society of Testing and Materials: West Conshohocken, PA, **2010**.
- 13.3.23 *Refined Lead*, Book of ASTM Standards; B29; American Society of Testing and Materials: West Conshohocken, PA, **2009**.
- 13.3.24 *Seamless Copper Tube*, Book of ASTM Standards; B75; American Society of Testing and Materials: West Conshohocken, PA, **2011**.
- 13.3.25 *Seamless Copper Water Tube*, Book of ASTM Standards; B88; American Society of Testing and Materials: West Conshohocken, PA, **2009**.
- 13.3.26 *Copper and Copper Alloy Forging Rod, Bar, and Shapes*, Book of ASTM Standards; B124; American Society of Testing and Materials: West Conshohocken, PA, **2012**.
- 13.3.27 *Copper-Zinc-Lead (Red Brass or Hardware Bronze) Rod, Bars and Shapes*, Book of ASTM Standards; B140; American Society of Testing and Materials: West Conshohocken, PA, **2007**.
- 13.3.28 *Aluminum Bronze Rod, Bar, and Shapes*, Book of ASTM Standards; B150; American Society of Testing and Materials: West Conshohocken, PA, **2008**.
- 13.3.29 *Nickel-Copper Alloy Rod, Bar, and Wire*, Book of ASTM Standards; B164; American Society of Testing and Materials: West Conshohocken, PA, **2008**.
- 13.3.30 *Nickel-Copper Alloy (UNS N04400) Seamless Pipe and Tube*, Book of ASTM Standards; B165; American Society of Testing and Materials: West Conshohocken, PA, **2009**.
- 13.3.31 *Nickel Alloy Forgings*, Book of ASTM Standards; B564; American Society of Testing and Materials: West Conshohocken, PA, **2011**.
- 13.3.32 *Low-Carbon Nickel-Chromium-Molybdenum, Low-Carbon Nickel-Molybdenum-Tantalum, Low-Carbon Nickel-Molybdenum-Copper, Low-Carbon Nickel-Molybdenum-Tungsten*, Book of ASTM Standards; B574; American Society of Testing and Materials: West Conshohocken, PA, **2010**.

13.3.33 *Low-Carbon Nickel--Chromium-Molybdenum, Low-Carbon Nickel-Chromium-Molybdenum-Copper, Low-Carbon Nickel-Chromium-Molybdenum-Tantalum, Low-Carbon Nickel-Chromium-Molybdenum-Tungsten, Low-Carbon Nickel-Chromium-Molybdenum-Chromium,,* Book of ASTM Standards; B575; American Society of Testing and Materials: West Conshohocken, PA, **2010**.

#### 13.4 OTHER REFERENCES

The following documents are specifically referenced in Pamphlet 6.

13.4.1 National Electric Code; NFPA 70; National Fire Protection Agency: Quincy, MA, **2011**.

13.4.2 *Code of Federal Regulations*. Title 29. Part 1910. Office of the Federal Register National Archives and Records Administration. U.S. Government Printing Office: Washington, DC, (revised annually).

13.4.3 *Valve Inspection and Testing*, ed. 8; API 598; American Petroleum Institute: Washington, DC, May **2004**.

13.4.4 *Brazing Nickel Alloy Filler Metal*; ANSI/SAE Aerospace Material Specification (AMS) 2675; Society of Automotive Engineers, **2006**.

13.4.5 *Cleaning Equipment for Oxygen Service*, ed. 6; Pamphlet G-4.1; Compressed Gas Association, Inc. Arlington, VA, **2009**.



**APPENDIX A: CHLORINE TRANSFER HOSE**

- A-1. Scope: This document describes parameters to be considered in the design, fabrication, installation and maintenance of chlorine transfer hoses used to connect chlorine shipping containers to stationary equipment and piping, or as temporary connections to purge and evacuate chlorine containing equipment and piping.
- A-2. Pressure and Temperature Ratings:
- A-2.1 Maximum Allowable Working Pressure: The minimum MAWP rating shall be equal to the pressure setting of the pressure relief device on the shipping container or system to which the hose is attached, but not less than:
- 375 PSIG at room temperature for hoses larger than ½” nominal diameter.
  - 500 PSIG at room temperature for hoses equal to or smaller than ½” diameter.
- A-2.2 Vacuum: Hoses shall not collapse or deform when subjected to full vacuum at room temperature in any configuration that does not exceed the minimum dynamic bend radius. Consult hose manufacturer for vacuum capabilities at elevated operating temperatures.
- A-2.3 Test Pressure: Prior to initial use in chlorine service, each hose shall be tested at room temperature to 2.3.1 and 2.3.2. Any indication of leakage is cause for rejection of the assembly.
- A-2.3.1 Each hose assembly shall be leak tested at two (2) times the MAWP with air, nitrogen, or helium (helium shall not be used for non-metallic hoses) gas for a minimum of ten (10) minutes under water. For safety reasons, it is suggested that this be preceded by a hydrostatic test at the same pressure. If the hose is hydrostatically tested prior to gas leak testing, the hose must be subjected to a drying procedure applicable to the hose’s material of construction to assure that all moisture is removed from the interior of the hose. If the chafe guard does not allow for visual inspection of the braid, the pressure test is to be done prior to installing the chafe guard.
- A-2.3.2 Each metallic hose assembly shall be pressure tested at two (2) times the MAWP and shall be Helium Mass Spectrometer tested to a maximum leak rate of  $5 \times 10^{-6}$  std cc/sec. If the hose is hydrostatically tested prior to Helium Mass Spectrometer leak testing, the hose must be subjected to a drying procedure applicable to the hose’s material of construction to assure that all moisture is removed from the interior of the hose.
- A-2.4 Weld Inspection: All pressure containing welds shall be 100% radiographed and/or dye penetrant tested and/or Helium Mass Spectrometer tested to a maximum leak rate of  $5 \times 10^{-6}$  std cc/sec
- A-2.5 Burst Pressure: A representative sample hose, at least 18” in length (not including end fittings), and fabricated using the same materials and procedures as the hose to be used in chlorine service, shall be hydrostatically tested to failure (bursting or otherwise breaking at any seam or joint). The sample hose shall not fail at a

pressure less than five times the MAWP. A sufficient number of sample hoses are to be tested in this manner, at a frequency sufficient to assure the hose supplier, fabricator, and end user that the integrity of the hose (design and manufacture) is being maintained.

A-2.6 Deformation Pressure: The pressure at which there is a marked permanent increase in internal volume without a corresponding increase in length [deformation pressure] must be greater than one and a half [1.5] times the MAWP.

A-2.7 Design Temperature: The hose shall be capable of operating at the MAWP between -40°F (-40°C) and 122°F (50°C).

A-3. Hose Dimensions: The length of the hose should be kept to a practical minimum. This will limit the hose weight and minimize the chance of twisting or kinking of the hose.

The nominal hose diameter should be the minimum required to achieve the desired chlorine transfer rate, but not less than ¼" or greater than 2 inches.

A-4. Materials of Construction: Hoses shall be of either metallic or non-metallic construction as described below:

A-4.1 Metallic Hoses:

- The inner core shall be Monel 400 (UNS N0440) or Hastelloy C-276 (UNS N10276).
- The braid shall be Monel 400 (UNS N04400), Hastelloy C-276 (UNS N10276) or Hastelloy C-22 (UNS N06022).
- 4.1.3 The outer covering (chafe guard) shall be Series 300 stainless steel.
- 4.1.4 The wetted end fittings shall be constructed of the same material as the inner core.

A-4.2 Non-metallic Hoses:

- The inner core shall be virgin, unfilled PTFE with or without fiberglass reinforcement. An inner layer of carbon black filled PTFE, or through-thickness carbon impregnated PTFE core (Note: the addition of carbon may increase the permeability of chlorine through the hose), can be used to increase electrical conductivity if static discharge is a concern.
- The braid shall be PVDF or Hastelloy C-276 (UNS N10276).
- The outer covering (chafe guard) shall be one of the following:
- Chlorinated polyethylene (CPE) with sufficient openings along the entire length of the hose to permit chlorine, which may permeate the inner core, to be vented.

- HDPE spiral guard with open pitch to allow inspection of the braid.
- PVDF open weave chafe sleeve.
- The wetted end fittings and collars shall be Monel 400 (UNS NO4400) or Hastelloy C-276 (UNS N10276).
- Chafe guard collars shall be 300 series stainless steel.

A-5. End Attachments:

A-5.1 Metallic Hoses: End fittings shall be attached by a welder qualified (per ASME Section IX) to weld the specified materials and to make the required joint(s). **All welders are required to have WPS [welder performance qualification] as well as PQR (Procedure Qualification Record) for all hose sizes.**

A-5.1.1 The weld joints shall be either Method 1 or 2, as illustrated in Fig.1.0.

A-5.1.2 Welding dissimilar materials on pressure retaining, wetted joints is not permitted.

A-5.1.3 The outer covering (chafe guard) shall be attached at both ends of the hose by welding to the end fitting at least 1 inch past the wetted pressure retaining joint.

A-5.2 Non-metallic Hoses: End fittings shall be attached by crimping the inner core and braid in a Monel or Hastelloy collar. The outer covering (chafe guard) shall be permanently attached to the end fittings.

A-5.2.1 Dimensions that are used for quality control in hose assemblies should be specified in hose assembly procedures. A crimp dimension should be specified for the collars that are used to secure the end attachments of the hose, braid and guard to the end fitting of the hose. The hose manufacturer should have design and testing documentation that verify that the crimp dimensions when within the specified tolerances will produce a hose assembly that meets the performance requirements.

A-6. Types of End Fittings: End fittings shall be Schedule 80 stub ends or nipples with hex wrench pads (1 inch minimum width). The end fittings shall be fabricated without elbows or tees and shall have a maximum length of 6 inches. For chlorine cylinders and ton containers, the CGA 820 connection is acceptable. The ends shall be one of the following types:

- Male NPT.
- Type A lap joint, 300 Class ASME flange.
- CGA 820 connection (for chlorine cylinders and ton containers).

A-7. Miscellaneous Design Requirements:

A-7.1 Inner Core (metallic hose): All metal hose design should be based on performance testing.

A-7.1.1 Each hose should have a 5:1 safety factor from burst pressure as well as a 2:1 safety factor from 15% deformation. Regardless of diameter, in order to obtain a minimum of 375 psi working pressure, the burst pressure must be greater than 1875 psi and deformation pressure must be greater than 750 psi.

A-7.1.2 For assemblies  $\frac{1}{2}$ " and under the MAWP is 500 psi. This will correspond to a 2500 psi burst and a 1000 psi deformation pressure.

A-7.1.3 For assemblies using 2 different hoses in its construction (i.e. an inner transfer hose with an outer hose acting as a guard) the bend radius must be calculated based on the lowest value of either hose.

A-7.2 Inner Core (non-metallic hose): All non-metallic hose design should be based on performance testing. One continuous length of convoluted (smooth bore optional for  $\frac{1}{2}$  inch and below), virgin PTFE with or without fiberglass reinforcement.

A-7.2.1 Each hose should have a 5:1 safety factor from burst pressure. Regardless of diameter, in order to obtain a minimum of 375 psi working pressure, the burst pressure must be greater than 1875 psi.

A-7.2.2 For assemblies  $\frac{1}{2}$ " and under the MAWP is 500 psi. This will correspond to a 2500 psi burst and a 1000 psi deformation pressure.

A-7.2.3 For assemblies using 2 different hoses in its construction (i.e. an inner transfer hose with an outer hose acting as a guard) the bend radius must be calculated based on the lowest value of either hose.

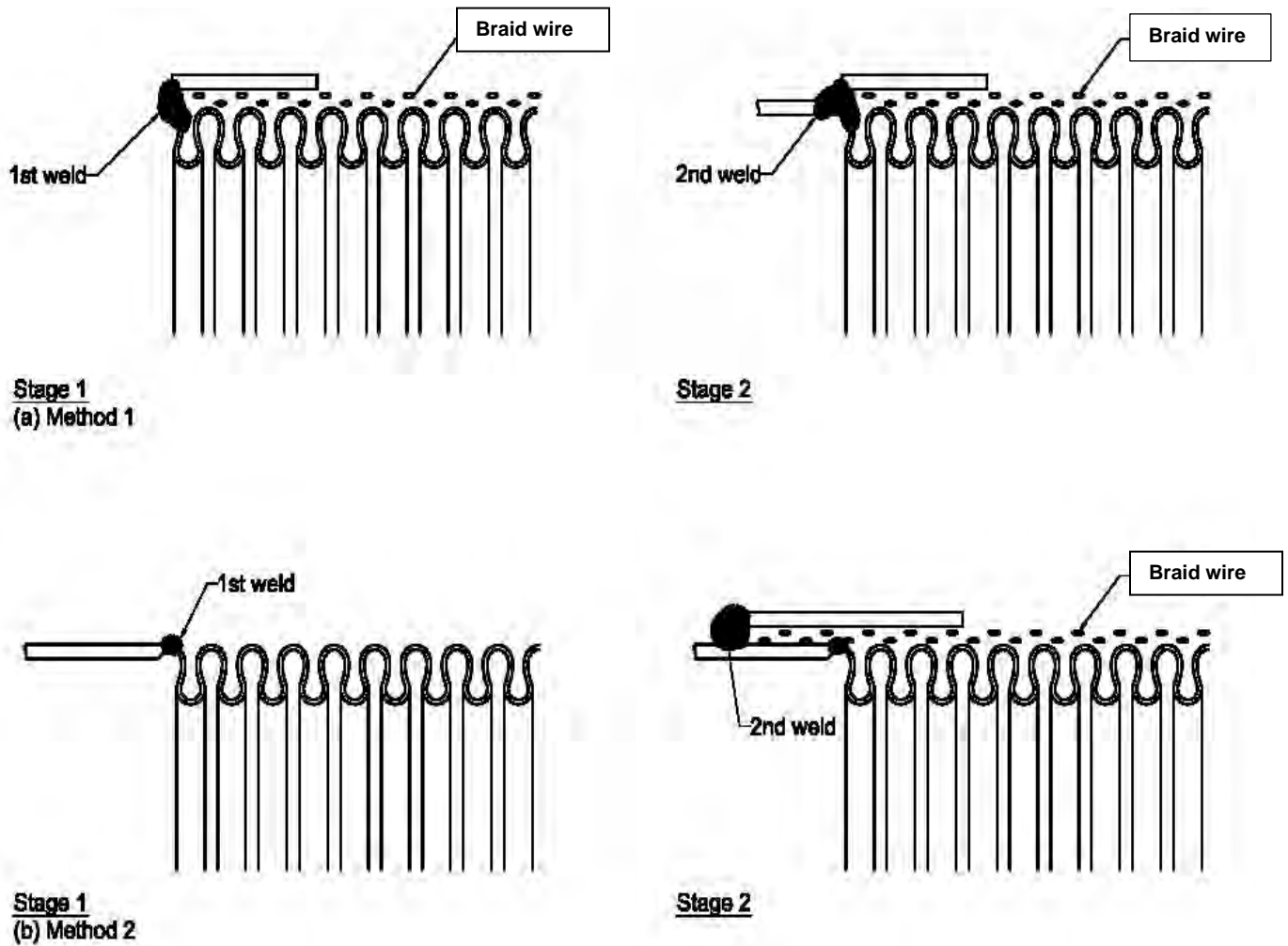

**Fig. 1.0**  
**Welding of End Fitting, Ferrule and Braid to Hose**

- A-7.3 **Braid:** Multiple monofilament fibers or wire shall be braided in a diamond or basket weave pattern and permanently attached to both ends of the hose. Multiple layers of braid shall be used to meet the pressure specifications, as required.
- A-7.4 **Bending Requirements:** The minimum bend radius (for metal hose as defined in ISO 10380) shall be no greater than 12 inches for hoses less than 2 inch nominal diameter and no greater than 15 inches for 2 inch nominal diameter hoses.

- A-7.4.1 Hose supports should be designed in such a manner that the hose is not subjected to a bend radius smaller than the manufactures specification. Hose supports should be designed to prevent kinking when stored but not connected to shipping containers or a process.
- A-7.5 Permeability (non-metallic): The inner core of non-metallic hoses is subject to some degree of permeability of chlorine. The braid and chafe guard shall be designed to allow chlorine which permeates the inner core to escape to atmosphere. Use of non-metallic hoses shall be limited to applications where adequate ventilation has been provided.
- A-8. Cleaning and Shipping:
- A-8.1 Prior to shipping, each hose assembly shall be cleaned to remove hydrocarbons, foreign materials and standing water. Note: prior to use in chlorine service, the hose shall be cleaned and dried at the site of use as required to meet cleaning recommendations found in Section 11.1 of this Pamphlet.
- A-8.2 Hose assemblies shall be wrapped in water tight packaging and boxed in containers that will prevent damage to the hose in transit. Alternatively, hoses may be shipped with securely fitted pipe caps on the end fittings.
- A-9. Marking: Each hose shall be identified with the following information, permanently attached to the hose, by coating, stenciling or stamping:
- A unique serial number, assigned by the final hose assembler that can be used to obtain hose documentation.
  - The final assembler company's name.
  - The date of final assembly (month and year).
  - The minimum allowable bend radius.
  - The statement "Chlorine per C.I. Pam. 6" to indicate compliance with all requirements of this document.
- A-10. Documentation: The following documentation is to be kept by the final hose assembler's company and made available to the customer:
- Hose design qualification (pressure, temperature, vacuum rating, bend radius, materials of construction, etc.).
  - Assembler training and certification records.
  - Positive material identification documents.
  - Final crimp dimensions (Non-metallic hoses only).

- Pressure test records and certification that a sample hose, built to the same specifications, has passed the burst test within the last 12 months.
- Radiograph and/or dye penetrant and/or Helium Mass Spectrometer reports for all welds.
- Certification that the hose has been cleaned as required by this document.
- Final inspection reports.
- Certification of compliance with most current Chlorine Institute Pamphlet 6.

A-11. Installation and Use:

- A-11.1 Hoses shall be installed in accordance with Fig.2.0.
- A-11.2 A visual examination shall be carried out prior to each use of the hose to detect any signs of discoloration, excessive bending (kinks), tears or other signs of stress. Hoses with visible signs of deterioration shall be removed from service.
- A-11.3 The use of external supports, such as slings, should be considered to reduce stresses on the hose and to aid in handling of the hose assembly.
- A-11.4 As a preventative maintenance measure, hoses should be replaced on a periodic basis, based on statistical data collected at each user facility. However, hoses should not be kept in service for more than 24 months.

A-12. Manufacturers, Distributors and Owners Responsibilities

- A-12.1 Dimensional and material specifications should be controlled for the components of the hose assembly and be identical to qualified prototype hose(s).
- A-12.2 An acceptance process should be used for component manufacturers.
- A-12.3 Hose component and assembly quality assurance practices need to demonstrate a *“continuous positive material identification of the chlorine hose throughout the supply chain.”*
- A-12.4 Hose assembly procedures must be documented and strictly adhered to.

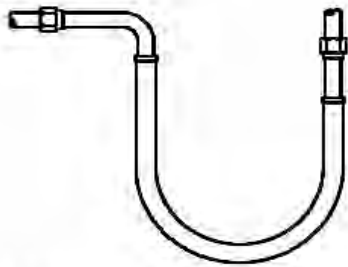

(a) **CORRECT.** The drawing illustrates the correct way to install a hose assembly in loop form. Note the free bend of the hose and that there are no sharp bends near either of the fittings.

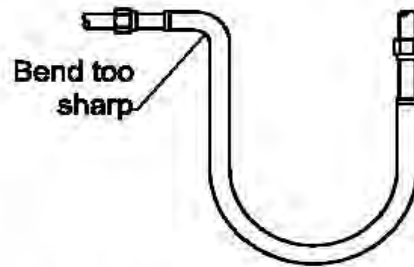

(b) **INCORRECT.** An illustration of this type is incorrect because there is a sharp bend near the upper fitting. If the hose assembly is installed in this manner, fatigue failure may result near the fitting.

NOTE: Piping configurations should be such to minimize stress and undue bends placed upon hoses.

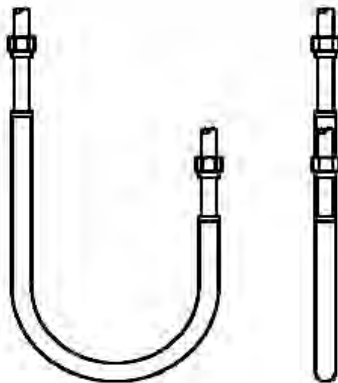

(c) **CORRECT.** The drawing demonstrates the manner of installing a hose assembly so that the hose during all movement will be in one plane. Note that there are no sharp bends near either fitting.

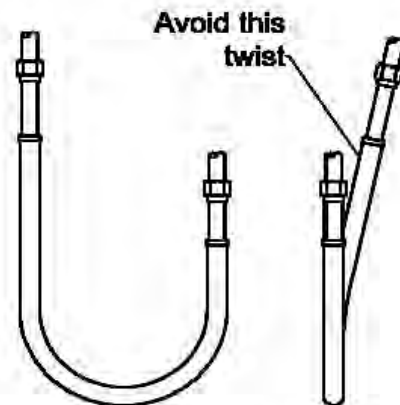

(d) **INCORRECT.** A hose assembly should not be installed like this when it will be required to move. Note that the fittings are not in line and that the hose is in torsion. When installed in this manner the twist in the hose may cause premature fatigue failure.

**Fig. 2.0**  
**Correct Installation of Hose Assemblies**



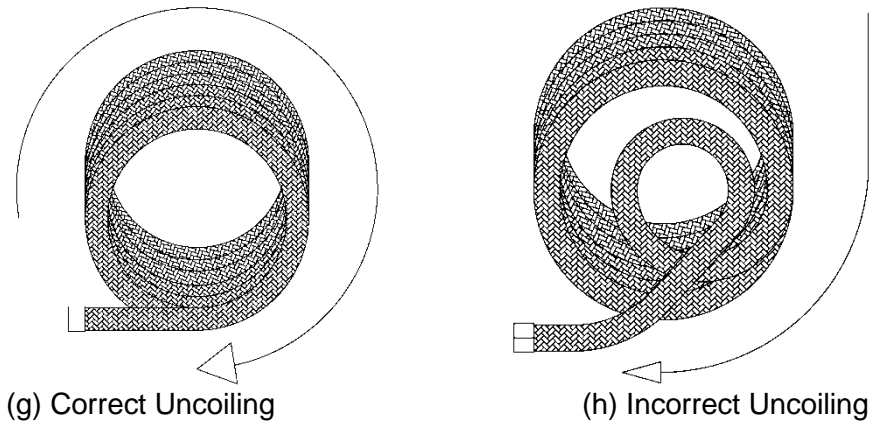
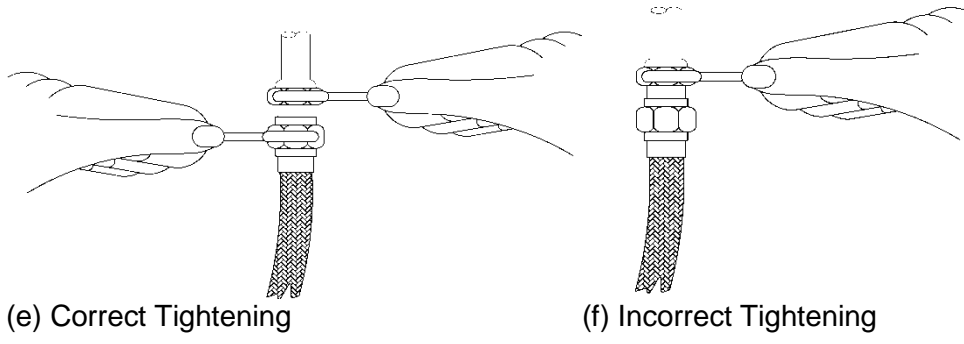

**Fig. 2.0**  
**Correct Installation of Hose Assemblies, Cont'd.**

- A-12.5 Hose testing per the requirements of this Pamphlet must be documented.
- A-12.6 Persons involved in the manufacture, assembly and testing of hose components and assemblies should be trained in the procedures pertaining to these activities. Records of successful completion of training to be available.
- A-12.7 Non-conforming hose components or assemblies should be documented and corrective actions taken to prevent a recurrence.
- A-12.8 Manufacturers' Responsibilities
- A-12.8.1 The hose manufacturer's role is to produce a hose assembly that meets the customer's specifications.
- A-12.8.2 The hose manufacturer will have the systems in place to assure that the hose and its components are correct.
- A-12.8.3 If the hose manufacturer has a distributor assembling hoses from component that it supplies, then, the manufacturer must have a system in place to verify that its quality assurance procedures are being followed.
- A-12.9 Distributors' Responsibilities
- A-12.9.1 The role of a hose distributor that performs hose assembly is to produce a hose assembly that meets the customer's specifications following the manufacturer's procedures.
- A-12.9.2 The hose distributor's role is to use hose storage practices that do not damage or contaminate the hose assembly.
- A-12.9.3 The hose distributor must supply a hose assembly that meets the customer's specifications.
- A-12.10 Owners' Responsibilities
- A-12.10.1 Audit the manufacturer and/or assembler companies to verify that they are complying with the requirements of this Pamphlet.
- A-12.10.2 Upon receipt, owner should make an inspection and verify material via the traceability reports.
- A-12.10.2 Install the hose correctly to avoid excessive stresses on the hose.
- A-12.10.3 Use the hose in applications that do not exceed the hose design criteria and that minimize ingress of moisture into the hose at all times.
- A-12.10.4 Inspect, maintain and replace the hoses on a regular basis.

---

A-13. References

*Pipework -- Corrugated metal hoses and hose assemblies*, ISO 10380:2012, an ISO standard; International Organization for Standardization: Geneva, Switzerland, **2012**.

*Pipe Flanges and Flanged Fittings, NPS 1/2 Through NPS 24 Metric/Inch Standard*, ASME B16.5 2003, an ANSI Standard; The American Society of Mechanical Engineers: New York, NY, **2003**.

*Hose Safety Institute Handbook (Specifically Corrugated Metal Hose Assembly Specification Guidelines)*, Association for the Hose and Accessories Distribution (NAHAD): Annapolis, MD **2013**.

*Corrugated Metal Hose Design and Fabrication Guides*, Association for the Hose and Accessories Distribution (NAHAD): Annapolis, MD **2005**.

## APPENDIX B: CHLORINE SERVICE – FLUID CATEGORY

The Chlorine Institute began issuing detailed recommendations for piping systems in 1960. Since 1976, those recommendations have stated that chlorine piping systems be built to conform to the specifications set forth in the ASME B31.3 *Process Piping Code Section (13.2.8)*.

ASME has recognized that the level of risk is best determined by the system owner and has called for the owner to be ultimately responsible for the system design. That philosophy was formalized in the 1976 edition of the Code, where three categories of fluid service were identified. One of those was Category M.

The Chlorine Institute reviewed the Category M definition in 1981 and formally concluded that chlorine did not meet the criteria outlined for Category M Fluid Service.

The Chlorine Institute, as noted in this pamphlet, continued to recommend design to B31.3, but did not recommend fluid service as that was the responsibility of the system owner.

The Category M issue was reviewed by the Chlorine Institute in 1988 following ASME's Code revision of that year, and the Chlorine Institute did not change its opinion. (The Institute is not aware of anything that has occurred that will change this position.)

A 1998 Institute review has developed the following policy:

*The membership of the Institute is against any blanket requirement relative to Category M Fluid Service design for chlorine systems.*

This statement is based on the following facts:

The owner is required to determine fluid service based upon a decision process outlined within the ASME code.

It is the policy of the Institute and its members that technical decisions should be made based on detailed risk analysis. While some portions of Category M requirements can lead to safety improvements, there are cases where strict design adherence to Category M service may lead to increased risk due to need to substitute less desirable materials for currently used piping components.

Within the code decision process, two key parameters must be met for the code to require design to Category M service. A copy of the ASME decision chart is attached. Following are comments on those parameters.

The first parameter in the code decision process states “a very small quantity causing irreparable harm, even when prompt restorative measures are taken”. ASME has, in the past, formally declined to define a small quantity. Two separate groups have assessed the health effects due to exposure to chlorine. Their findings are summarized below:

On October 30, 1997, EPA proposed in the Federal Register recommendations of its National Advisory Committee pertaining to acute effects of exposure to several substances including chlorine. The committee has developed Acute Exposure Guideline Levels (AEGs) for four exposure periods (30 minutes, 1 hour, 4 hours and 8 hours) for each of three severity levels: AEG-1, AEG-2 and AEG-3.

Airborne concentrations below AEG-3 but above AEG-2 represent average exposure concentrations for the defined time period which may cause irreversible or other serious, long lasting effects or impaired ability to escape in the general population, including susceptible but excluding hypersusceptible individuals. These levels have been developed without consideration of prompt restorative measures which may mitigate any potential health impact. The 30 minute AEG-3 and AEG-2 were proposed at 28 ppm and 2.8 ppm, respectively.

The American Industrial Hygiene Association (AIHA), Fairfax, VA has reviewed a similar body of scientific evidence as the EPA advisory committee. AIHA has published an Emergency Response Planning Guideline (ERPG) for chlorine and many other chemicals. Three toxic severity levels are used: ERPG-1, ERPG-2 and ERPG-3. ERPG-2 is the maximum airborne concentration below which it is believed that nearly all individuals could be exposed for up to 1 hour without experiencing or developing irreversible or serious health effects or symptoms which could impair their ability to take protective action. Prompt restorative measures were not considered when developing the ERPGs. The ERPG-2 for chlorine is 3 ppm.

The IDLH (NIOSH) for chlorine is 10 ppm.

Several researchers have evaluated the effects of chlorine exposure. Ellenhorn and Barceloux (1988) compiled a listing of chlorine exposure thresholds and estimated clinical effects which are listed below:

- 1 - 3 ppm -- mild, mucus membrane irritation, tolerated up to 1 hour
- 5 - 15 ppm -- moderate irritation of the respiratory tract
- 30 ppm -- immediate chest pain, vomiting, dyspnea, cough
- 40 - 60 ppm -- toxic pneumonitis and pulmonary edema
- 430 ppm -- lethal over 30 minutes
- 1000 ppm -- fatal within a few minutes

Clearly, these values indicate that a single exposure to greater than a very small quantity of chlorine does not cause serious, irreversible harm on breathing or bodily contact.

The second parameter deals with system integrity. Through history, chlorine piping systems have not experienced “significant” releases as noted in B31.3 that would have been prevented by the design changes required under Category M. Chlorine leaks from piping systems historically start from either physical damage or as very small leaks resulting from corrosion due to moisture intrusion.

While many aspects of design requirements listed within Category M can enhance system integrity, several are based on refinery and other high pressure, high temperature applications where mechanical properties of steel become limited. Some of these can introduce safety issues into chlorine systems. There are many examples where system integrity could be compromised or substitutions to less reliable components may be required for strict adherence to Category M. Three of them follow.

- Thermoplastic construction is universally used in drinking and wastewater chlorination. This construction gives the optimum balance of corrosion protection and mechanical integrity in this low pressure, wet chlorine environment. Nonmetallic construction is prohibited within Category M.
- Connections to chlorine transportation containers are made with either reinforced metallic or reinforced fluoropolymer hose. Depending on type, either nonmetallic pressure containment elements or brazed joints are integral components of the designs. These are not allowed within Category M. Mechanically sealed swivel joint systems would have to be developed.
- Miter bends are often used in pressure relief device vent systems to limit backpressure. Substitution to standard elbow components to comply with Category M will not enhance system safety.

It is good practice for users to develop site-specific chlorine piping specifications that use the recommendations outlined in Pamphlet 6 as a base and consider including elements of Category M requirements (such as NDT examination) that enhance reliability at their sites.

In summary, The Institute position relative to Category M design is as follows:

- The owner is responsible for determining fluid class.
- A single exposure to a very small quantity of chlorine does not cause irreversible harm.
- Current design practices have been adequate to prevent significant releases.
- Chlorine piping system reliability can only be assured by a combination of site-correct specification and design coupled with proper operation, inspection and maintenance.

Fig. M300 Guide to Classifying Fluid Services

(1.0)

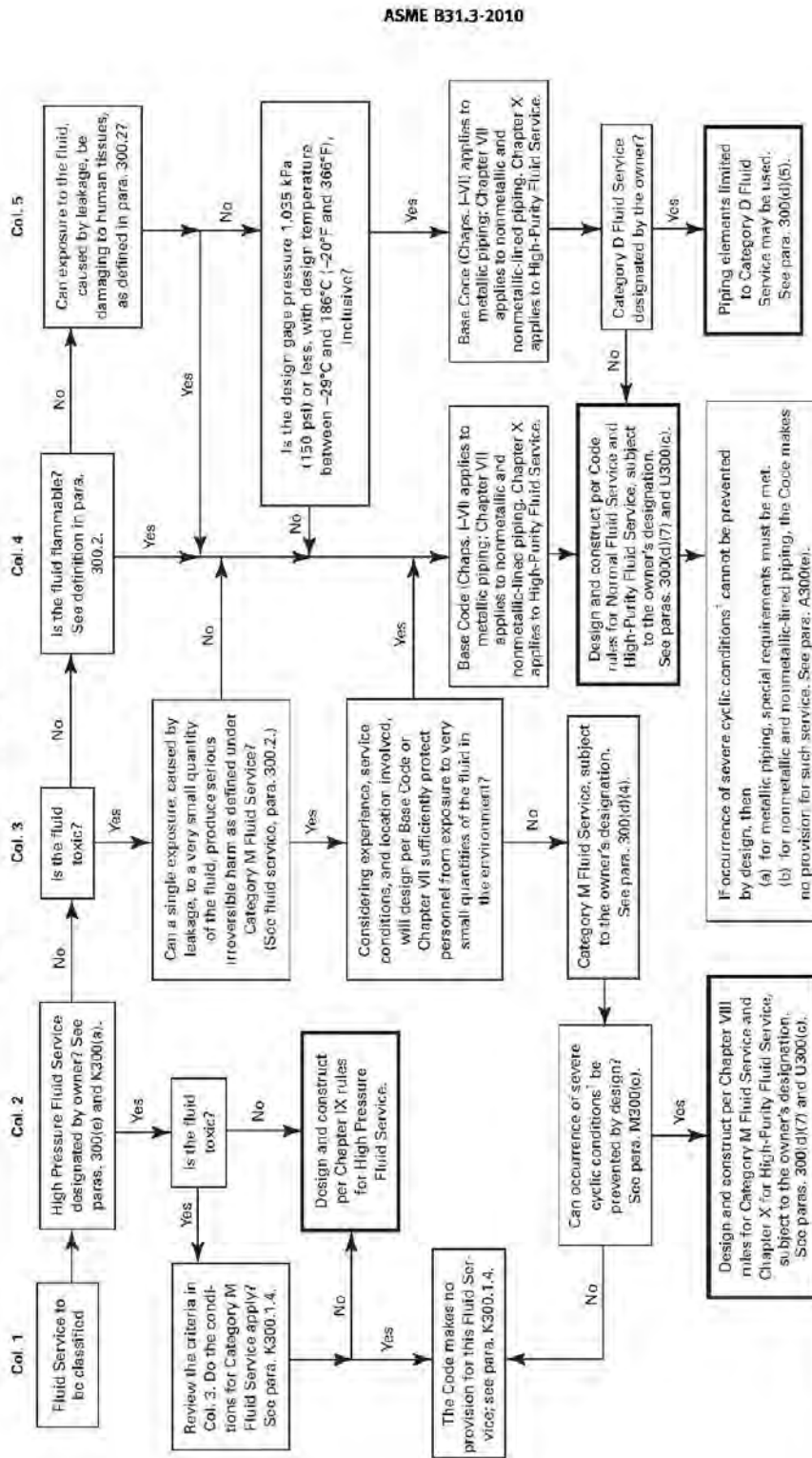

GENERAL NOTES:

- (a) See paras. 300(b)(1), 300(d)(4) and (5), and 300(e) for decisions the owner must make. Other decisions are the designer's responsibility; see para. 300(b)(2).
- (b) The term "fluid service" is defined in para. 300.2.

NOTE:

- (1) Severe cyclic conditions are defined in para. 300.2. Requirements are found in Chapter II, Parts 3 and 4, and in paras. 323.4.2 and 241.4.3.

---

## APPENDIX C: RECOMMENDATIONS TO MINIMIZE EFFECTS OF MOISTURE IN DRY CHLORINE SYSTEMS

This document addresses concerns of moisture intrusion into dry chlorine systems.

### Material Specifications

At ordinary temperatures, dry chlorine, either liquid or gas, does not corrode steel. Wet chlorine is highly corrosive because it tends to form acids. These acids react with the steel.

Dry liquid chlorine is defined as liquid chlorine with its water content dissolved in solution. Dry gaseous chlorine is defined as chlorine which contains moisture exerting a vapor pressure of no more than 2 millimeters of mercury. Application of these definitions and analytical descriptions are given in Chlorine Institute Pamphlet 100, *Dry Chlorine: Behaviors of Moisture in Chlorine and Analytical Issues*.

Carbon steel is the general material of choice for dry chlorine systems. The following Chlorine Institute publications outline detail material choices for chlorine equipment:

Pamphlet 5, *Bulk Storage of Liquid Chlorine*  
Pamphlet 6, *Piping Systems for Dry Chlorine*  
Pamphlet 9, *Chlorine Vaporizing Systems*  
Pamphlet 95, *Gaskets for Chlorine Service*

### Moisture Prevention and Corrective Measures

Chlorine in commerce as produced and shipped typically contains less than 100 ppm moisture. This moisture level is well below the defined limit for dry chlorine.

Chlorine consumers should take all necessary precautions to keep chlorine and chlorine equipment dry. Moisture might be introduced into chlorine systems under the following conditions:

**Start-up and Shutdown:** The chlorine system should be thoroughly dried before use and following maintenance. The chlorine system drying procedure usually involves heating the system followed by purging with a dry gas until the gas exiting the system is at a dew point of -40°F (-40°C).

**Wet pad purge gases:** If compressed air is used to pressurize shipping equipment for chlorine transfer, the air system should deliver reliably dry air at a dew point below -40°F (-40°C) at the operating pressure.

**Exposure to atmosphere:** Chlorine systems piping, valves and containers should be closed or capped immediately to keep out atmospheric moisture when not in use and particularly if and when disconnecting under vacuum conditions. Before attachment of any 'pipe stabber', 'pipe nipple', etc. to bulk shipping containers, verify the component has been adequately dried to a dew point below -40°F (-40°C).

If the chlorine system becomes contaminated with moisture and corrosion is indicated by buildup of ferric chloride, the system should be emptied, purged of chlorine, washed out, dried and then inspected to ensure sufficient integrity of the system.



---

### Adverse Consequences

Excessive moisture in chlorine results in metal loss and formation of ferric chloride.

Metal loss can affect the system integrity and necessitate component replacement. There should be an inspection program for corrosion products. Periodic thickness checks of system components, particularly at elbows or other potential high turbulence areas should be part of the plant preventative maintenance system.

Ferric chloride can plug small lines, especially instrument connections, leading to potential loss of process indication.

A combination of metal loss and buildup of ferric chloride can cause valves to leak through and/or stick in position. A periodic valve test program for both manual and actuated valves should be part of the plant operating plan.

### APPENDIX D: PAMPHLET 6 CHECKLIST

This checklist is designed to emphasize major topics for someone who has already read and understood the pamphlet. Taking recommendations from this list without understanding related topics can lead to inappropriate conclusions.

Place a check mark (✓) in the appropriate box below:

Yes	No	N/A		
<input type="checkbox"/>	<input type="checkbox"/>	<input type="checkbox"/>	1. Systems are in place to assure that no burning or welding is done on piping containing chlorine.	{2.1}
<input type="checkbox"/>	<input type="checkbox"/>	<input type="checkbox"/>	2. Expansion properties of liquid chlorine have been considered	{2.1}
<input type="checkbox"/>	<input type="checkbox"/>	<input type="checkbox"/>	3. Dry chlorine systems are protected from intrusion of moisture	{2.1}
<input type="checkbox"/>	<input type="checkbox"/>	<input type="checkbox"/>	4. No titanium components are used in dry chlorine service.	{2.1}
<input type="checkbox"/>	<input type="checkbox"/>	<input type="checkbox"/>	5. Chlorine systems are properly cleaned and dried prior to being placed into service.	{2.1}
<input type="checkbox"/>	<input type="checkbox"/>	<input type="checkbox"/>	6. A chlorine piping inspection program is in place.	{2.1}
<input type="checkbox"/>	<input type="checkbox"/>	<input type="checkbox"/>	7. Materials of construction are based on temperature and fluid state.	{2.3}
<input type="checkbox"/>	<input type="checkbox"/>	<input type="checkbox"/>	8. Design and construction are appropriate for the intended service class	{2.3}
<input type="checkbox"/>	<input type="checkbox"/>	<input type="checkbox"/>	9. Pipe and piping components are consistent with Institute recommendations.	{3}
<input type="checkbox"/>	<input type="checkbox"/>	<input type="checkbox"/>	10. Valve type and materials are consistent with Institute recommendations.	{4}
<input type="checkbox"/>	<input type="checkbox"/>	<input type="checkbox"/>	11. Pressure relief devices are designed consistent with Institute recommendations.	{5.2}
<input type="checkbox"/>	<input type="checkbox"/>	<input type="checkbox"/>	12. Transportation valve components are only used in appropriate locations.	{5.4}
<input type="checkbox"/>	<input type="checkbox"/>	<input type="checkbox"/>	13. Expansion chambers are installed where required.	{5.5}
<input type="checkbox"/>	<input type="checkbox"/>	<input type="checkbox"/>	14. Non-ferrous system components are consistent with Institute recommendations.	{7}

Yes	No	N/A		
<input type="checkbox"/>	<input type="checkbox"/>	<input type="checkbox"/>	15. Transportation container connections are consistent with Institute recommendations.	{8}
<input type="checkbox"/>	<input type="checkbox"/>	<input type="checkbox"/>	16. Use of plastic materials is consistent with Institute recommendations.	{9}
<input type="checkbox"/>	<input type="checkbox"/>	<input type="checkbox"/>	17. Piping layout and design is appropriate for the intended chlorine service.	{10}
<input type="checkbox"/>	<input type="checkbox"/>	<input type="checkbox"/>	18. Proper procedures are in place to assure that systems are correctly prepared for use.	{11}
<input type="checkbox"/>	<input type="checkbox"/>	<input type="checkbox"/>	19. A system for periodic inspection and maintenance is in place.	{12}
<input type="checkbox"/>	<input type="checkbox"/>	<input type="checkbox"/>	20. Chlorine transfer hoses are consistent with recommendations of Appendix A.	{App A}

**REMINDER:**

**Users of this checklist should document exceptions to the recommendations contained in this pamphlet.**

# **DRAWINGS**

DRAWING 101-7: EXCESS FLOW VALVE WITH REMOVABLE SEAT

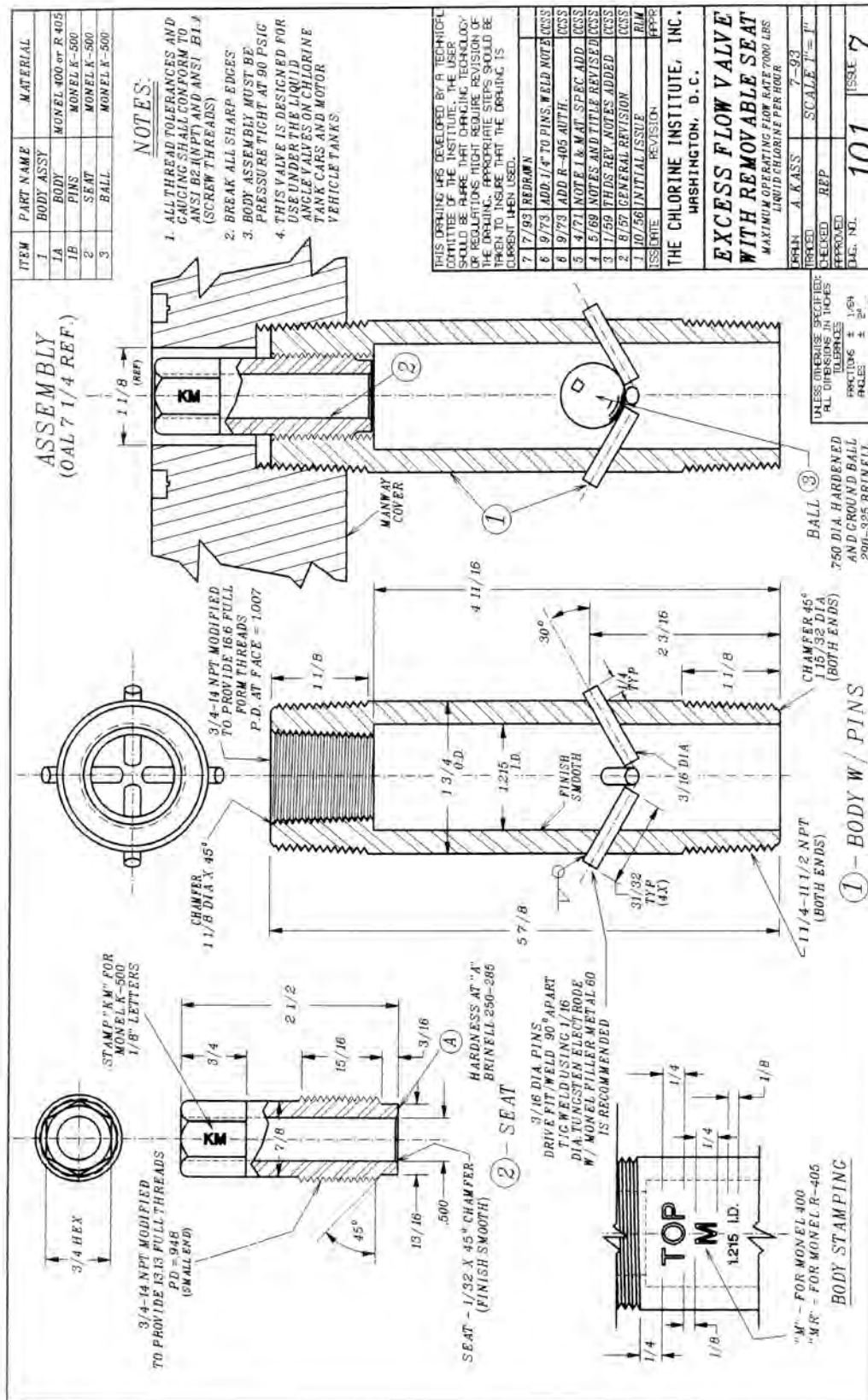

**DRAWING 102-12: STUDS, NUTS AND GASKETS FOR CHLORINE TANK MANWAY COVERS AND VALVES**

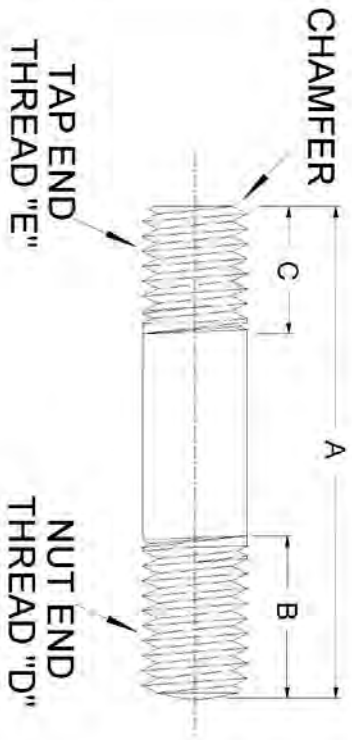

DIM	ITEM 1	ITEM 2	ITEM 2A	ITEM 3	ITEM 9	CLASS OR TOL.
A	3 3/4	3	2 5/8	4 1/2	4 1/8	+1/16,-0
B	2 3/8	1 5/8	1 1/4	2 3/4	1 3/8	+0,-1/16
C	7/8	7/8	7/8	1 1/4	1	+0,-1/16
D	3/4-10 UNC	3/4-10 UNC	3/4-10 UNC	1 1/8-7 UNC	3/4-10 UNC	2A
E	3/4-10 UNC	3/4-10 UNC	3/4-10 UNC	1 1/8-7 UNC	3/4-10 UNC	3A

**STUDS**

ITEM 6 - 3/4-10 UNC-2B (1 1/4 ACROSS FLATS)  
 ITEM 7 - 1 1/8-7 UNC-2B (1 13/16 ACROSS FLATS)  
 Material shall conform to ASTM A320 Grade L7 specifications including impact testing.

- NOTES:
- Dimensions in inches unless noted
  - Screw thread tolerance and grading shall conform to ANSI B1.1
  - Dimensions "B" and "C" exclude 1 to 1-1/4 imperfect threads
  - Lock washers not permitted
  - Cargo tank parts are identical to tank car parts
  - Dimensions "D" and "E" shall include chamfer
  - Thread tolerances shall conform to the proper thread dimensions
  - Gasket tolerances to be determined by the supplier in conjunction with the end user

ITEM	PART	USE
1	STUD	Tank car and cargo tank pressure relief device (1 1/2 JQ)
2	STUD	Standard angle valve and tank car protective housing. (see NOTE 7)
2A	STUD	Alternate angle valve. (see NOTE 7)
3	STUD	Tank car and cargo tank manway cover.
4	GASKET	Angle valve, pressure relief device (1 1/2 JQ)
5	GASKET	Tank car and cargo tank manway cover.
6	NUT	Angle valve, pressure relief device (1 1/2 and 4JQ) tank car and cargo tank protective housing.
7	NUT	Tank car and cargo tank manway cover.
8	GASKET	Tank barge pressure relief device (4JQ)
9	STUD	Tank barge pressure relief device (4JQ)

**GASKETS**

DIM	ITEM 4	ITEM 5	ITEM 8
OD	2 1/4	20 1/4	6 3/16
ID	1 1/2	19 1/4	5 3/16
THICK	1/8	1/8	1/8

MATERIAL: Pair gasket material section in pamphlet 95

**NUTS**

Nuts shall be heavy series, semifinished hexagon type in conformance with ANSI B18.22 & ASTM A194

THIS DRAWING WAS DEVELOPED BY THE CHLORINE INSTITUTE FOR THE DEVELOPMENT OF THE CHLORINE TANK MANWAY COVER AND VALVE. THE USER SHALL BE RESPONSIBLE FOR CHECKING THE SPECIFICATIONS AND MATERIALS AGAINST THE REQUIREMENTS OF THE CHLORINE TANK MANWAY COVER AND VALVE. THE CHLORINE INSTITUTE SHALL NOT BE RESPONSIBLE FOR ANY DAMAGE TO THE DRAWING OR THE USER'S EQUIPMENT.

12 (06/10) ADDED NOTE B  
 11 (06/10) ADDED "2A" REVISED NOTES  
 10 (1/01) CLARIFIED USE & MAT. NOTES  
 9 (7/93) RETRAVAIL  
 8 (8/83) CORRECT DIM. "C", ITEM 2 & 9  
 7 (9/82) ADD NOTE 6  
 6 (11/82) GASKET SPEC. UPDATED  
 5 (11/82) ADDED STUDS, 8C GASKET, ADDED 2C, 3  
 4 (11/82) ADDED STUDS, 8C GASKET, ADDED 2C, 3  
 3 (5/68) GENERAL REVISIONS  
 2 (1/58) THREADS REVISED TO UNC  
 1 (2/57) ISSUED

THE CHLORINE INSTITUTE, INC.  
 14501 CHLORINE DRIVE, CLEVELAND, OH 44130

STUDS, NUTS & GASKETS FOR CHLORINE TANK MANWAY COVERS & VALVES

FORMED BY: A. KASS 7-693  
 CHECKED BY: REP  
 APPROVED BY: [Signature]  
 DATE: 102 ISSUE: 12

DRAWING 104-9: STANDARD CHLORINE ANGLE VALVE ASSEMBLY

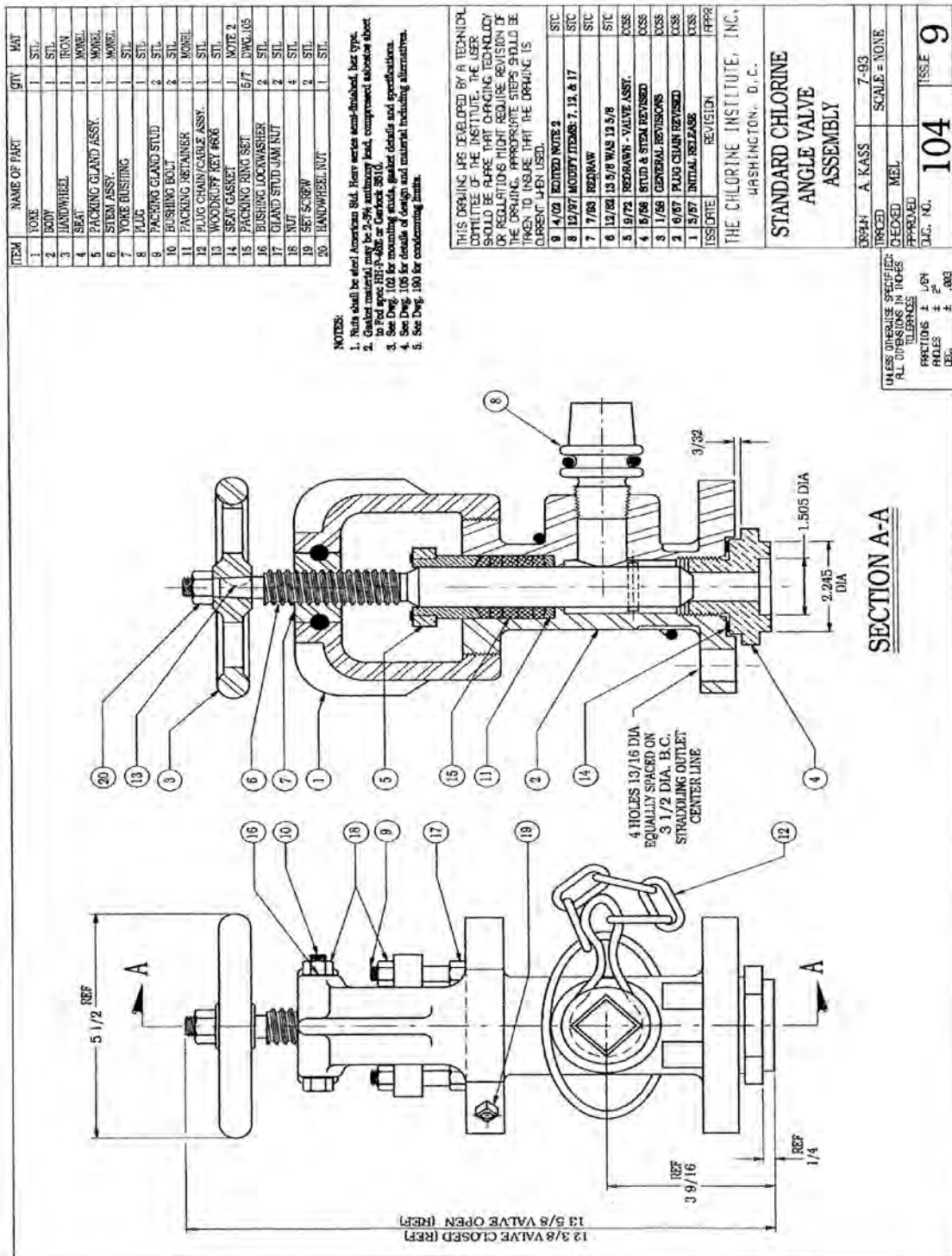

ITEM	NAME OF PART	QTY	MAT
1	YOKE	1	STL
2	BODY	1	STL
3	HANDWHEEL	1	IRON
4	SEAT	1	MONEL
5	PACKING GLAND ASSY.	1	MONEL
6	STEM ASSY.	1	MONEL
7	YOKE BUSHING	1	STL
8	PLUG	1	STL
9	PACKING GLAND STUD	2	STL
10	BUSHING BOLT	2	STL
11	PACKING RETAINER	1	MONEL
12	PLUG CHAIN/CABLE ASSY.	1	STL
13	WOODRUFF KEY #606	1	STL
14	SEAT GASKET	1	NOTE 2
15	PACKING RING SET	5/7	DWG. 05
16	BUSHING LOCKWASHER	2	STL
17	GLAND STUD W/AM NUT	2	STL
18	NUT	2	STL
19	SET SCREW	2	STL
20	HANDWHEEL NUT	1	STL

NOTES:  
 1. Nuts shall be steel American Std. Hex or steel semi-finished, hex type.  
 2. Gasket material may be 2-3/4 arbitrary lead, compressed asbestos sheet to Fed spec. B31-3-405 or Graphite 381(U).  
 3. See Dwg. 102 for mounting studs, gasket details and specifications.  
 4. See Dwg. 100 for details of design and material including alternatives.  
 5. See Dwg. 100 for conditioning limits.

THIS DRAWING WAS DEVELOPED BY A TECHNICAL COMMITTEE OF THE INSTITUTE. THE USER SHOULD BE AWARE THAT CHANGING TECHNOLOGY OR REGULATORY REQUIREMENTS MAY REQUIRE REVISION OF THIS DRAWING. THE USER'S RESPONSIBILITY IS TO VERIFY THAT THE DRAWING IS CURRENTLY BEING USED.

9	4/92	REVISED	NOTES 3	SIC
8	12/87	MODIFY	NOTES 7, 12, & 17	SIC
7	7/83	REDRAW		SIC
6	12/80	13 5/8 WAS	12 5/8	SIC
5	5/79	REDRAWN	- VALVE ASSY.	CCSS
4	5/56	STUD & STEM	REVISED	CCSS
3	1/56	GENERAL	REVISIONS	CCSS
2	6/57	PLUG, CHAIN	REVISED	CCSS
1	5/57	INITIAL	RELEASE	CCSS
		ISSUANCE	REVISION	APPR

THE CHLORINE INSTITUTE, INC.  
 WASHINGTON, D. C.

STANDARD CHLORINE ANGLE VALVE ASSEMBLY	
DESIGN	A. KASS
TRACED	
CHECKED	MEL
APPROVED	
DWG. NO.	104
ISSUE	9
SCALE	NONE

UNLESS OTHERWISE SPECIFIED, ALL DIMENSIONS IN INCHES SHALL BE TO NEAREST DECIMAL FRACTIONS ± .005 UNLESS OTHERWISE SPECIFIED.

DRAWING 106-6: EXCESS FLOW VALVE WITH REMOVABLE BASKET

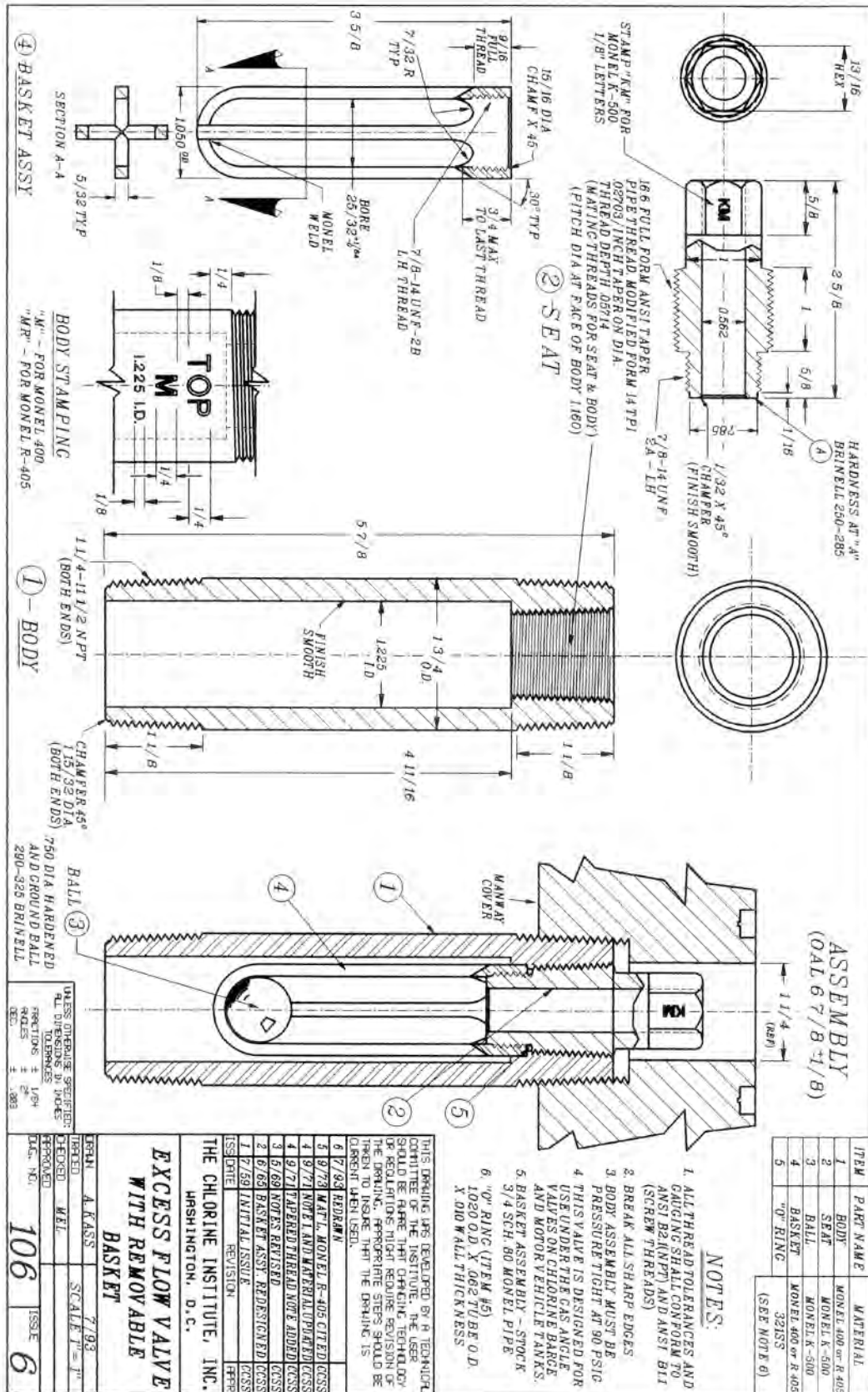



**DRAWING 110-4: VALVES FOR CHLORINE CYLINDER AND TON CONTAINER ASSEMBLIES**

**NOTES:**

1. APPROX. WEIGHT OF CYLINDER VALVE WITH OUTLET CAP - 24 OUNCES.
2. SEE DWG. 119, 115, 184, 185, AND 196 FOR VALVE PART DETAILS. SEE DRAWING 184 FOR OPTIONAL CYLINDER VALVE WITH 5/16 INCH DIAMETER ORIFICE.
3. SEE DRAWING 112 FOR MATERIALS AND TEST SPECS.
4. INLET AND OUTLET DIMENSIONS CONFORM TO ANSI/CSA/CGA-1.1. OUTLET CONFORM TO CONNECTION CGA 850, 1030-14 NGC-RH-EXT.
5. SEE CI PAMPHLET 17 FOR RECOMMENDED APPLICATIONS OF 1-11 1/2 NCT (CL)-5.
6. BODY TYPE "1B" NOT TO BE USED FOR NEW CONSTRUCTION.

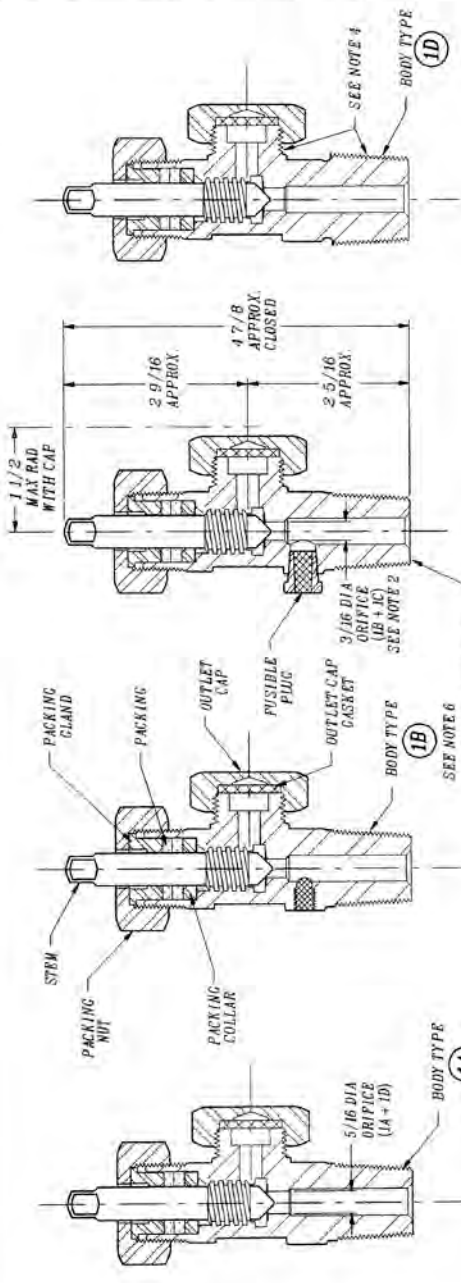

6			
5			
4	1-94	DRAWING CLARIFICATIONS	
3	2-93	REDRAW	PG
2	3-79	UPDATED NOTES	CCSS
1	5-58	INITIAL RELEASE	CCSS
		REVISION	FFFF
			FFFF
THE CHLORINE INSTITUTE, INC. WASHINGTON, D.C.			
<b>VALVES FOR CHLORINE CYLINDERS AND TON CONTAINERS ASSEMBLIES</b>			
DRW'N	A. KASS	3-93	
CHECKED	NEL	SCALE T=11/2"	
APPROVED			
DWG. NO.	<b>110</b>	ISSUE	<b>4</b>

1A TON CONTAINER VALVE (NO TAP)  
 1B CYLINDER VALVE (POURED PLUG, TAP 5/16-18 NC-1)  
 1C CYLINDER VALVE (REMOVABLE PLUG, TAP 1/8-27 NCT)  
 1D TON CONTAINER (NO TAP)

3/4-14 NCT (CL)-1	1-11 1/2 NCT (CL)-1
3/4-14 NCT (CL)-2	1-11 1/2 NCT (CL)-2
3/4-14 NCT (CL)-3	1-11 1/2 NCT (CL)-3
3/4-14 NCT (CL)-4	1-11 1/2 NCT (CL)-4
3/4-14 NCT (CL)-5	1-11 1/2 NCT (CL)-5
INLET CONNECTION 5 SIZES	(SEE NOTE 5)

DRAWING 111-7: 3/4 AND 1 INCH FUSIBLE PLUGS FOR CHLORINE TON CONTAINERS

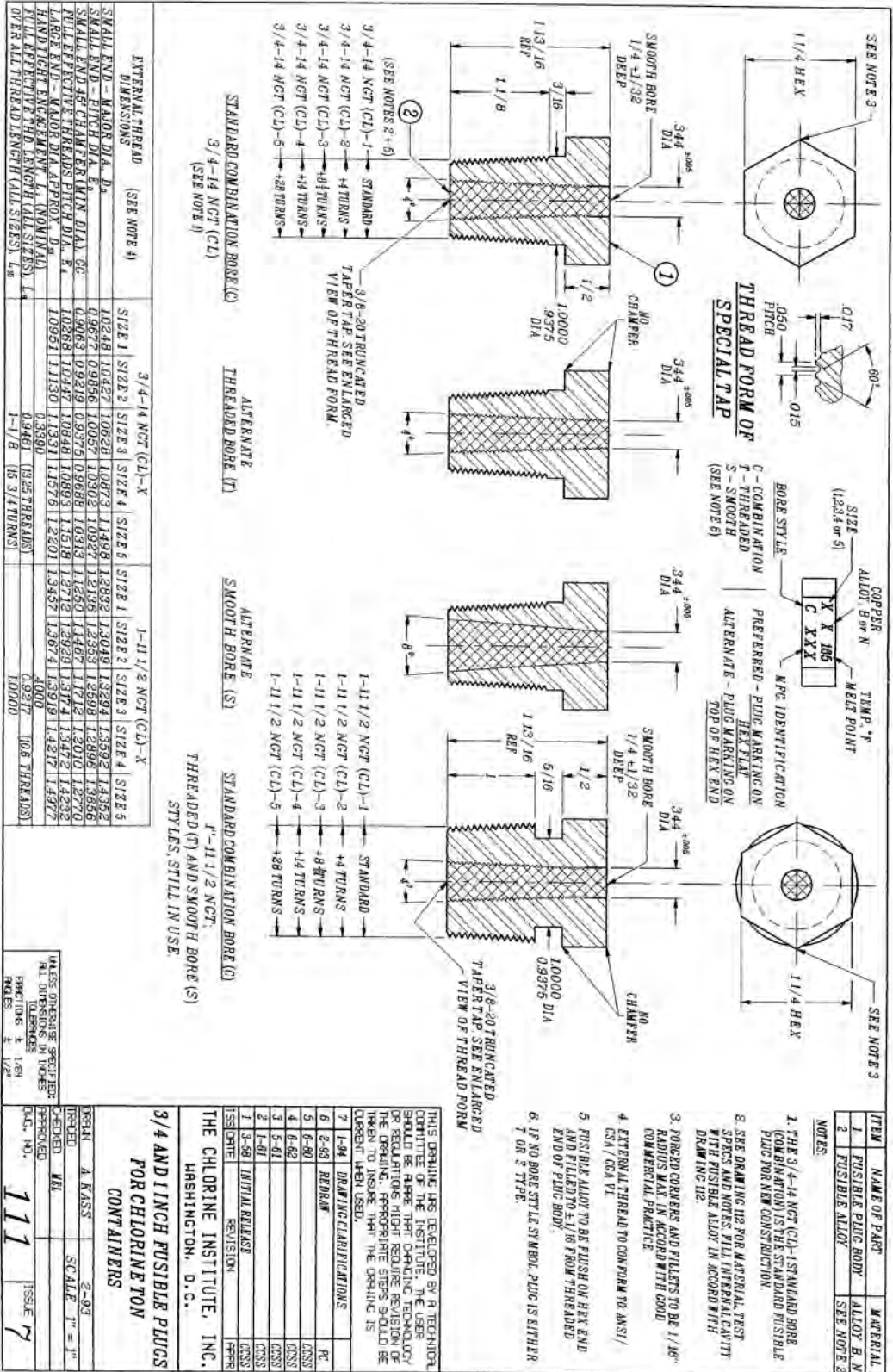

DRAWING 112-9: VALVE AND FUSIBLE PLUG FOR CHLORINE CYLINDERS AND TON CONTAINERS

MATERIAL SPECIFICATIONS		VALVE BODY FORGINGS	
1.1	Alloy "B"	1.9	Packing shall conform to CI Drawing 185.
1.1.1	Alloy "B" (Aluminum-Silicon Bronze) shall comply with Copper Alloy No. C64210 of the following ASTM Standard Specifications: B 164 - COPPER AND COPPER-ALLOY FORGING ROD, BAR, AND SHAPES B 164 - UNFINISHED COPPER AND COPPER-ALLOY ROD, BAR, AND SHAPES B 889 - GENERAL REQUIREMENTS WROUGHT COPPER AND COPPER-ALLOY ROD, BAR, AND SHAPES	2.0	Surface hardness of valve body forgings at the flash shall not exceed 500 PSI to inlet with valve closed and outlet cap removed. Immerse assembly in water with other suitable liquid and inspect for bubbles in the metal. The maximum hardness reading of 85.
1.1.2	It shall pass the 10-Day Moist Ammonia Air Stress Cracking Test per UL 1769 "Cylinder Valves", January 1989.	3.0	<b>PRESSURE TESTING PROCEDURE OF NEW VALVES AND FUSIBLE PLUGS</b>
1.1.3	Forgings shall be heat-treated at 1075-1125° F metal temperature for 4 hours and air-cooled.	3.1	The valve assembly shall be tested by applying air or inert gas at 500 PSI to inlet with valve closed and outlet cap removed. Immerse in water with other suitable liquid and inspect for bubbles in the metal. The maximum hardness reading of 85. Pressure test the open valve and test as above for leakage through packing, body and fuse plug.
1.2	Alloy "N" (NAVAL BRASS)	3.2	The fusible plug assembly shall be tested by applying air or inert gas at 500 PSI at the gas contact face. Immerse assembly in water or other suitable liquid or steam with soap suds and inspect for bubbles.
1.2.1	Alloy "N" shall comply with ASTM B 21, Alloys C46400, C48200, C48500 only.	3.2.1	Two representative samples of fusible plugs shall be selected at random from each lot and subjected to the tests prescribed in 3.2.2 and 3.2.3. If both samples should fail to meet the requirements of 3.2.2 and 3.2.3, three more samples to meet the requirements of 3.2.2 and 3.2.3, for additional samples shall be selected at random from the same lot and subjected to these tests. If any of these four additional samples fail to meet the requirements of 3.2.2 and 3.2.3, the lot shall be rejected. The production of either new or reconditioned fusible plugs by a manufacturer on any one day for any one range of minimum to maximum yield temperature, but in no case greater than 3000, shall constitute a lot.
1.3	RESERVED	3.2.2	A test to determine resistance to extrusion of the fusible alloy and leaks at a temperature of 130° F, or less, in a fusible plug shall be made as follows: Finished fusible plug shall be heated to 130° F for twenty-four hours with a gas pressure of 500 PSI on the end normally exposed to the contents of the container. In order to pass this test no leakage nor visible extrusion of material shall be evident upon examination of the end exposed to atmospheric pressure.
1.4	Fusible Alloy	3.2.3	A test for determining the yield temperature of a fusible plug shall be made as follows: Subject plugs to an air pressure of not less than 3 PSI applied to the end normally exposed to the contents of the container. While subjected to low pressure bath at temperature in the 5° F range, immediately below the specified minimum yield temperature, and held in that temperature range for a period of ten minutes. The temperature of the bath shall be raised at a rate not in excess of 5° F per minute during which the pressure may be increased to not more than 50 PSI. When the pressure is increased to 50 PSI, the specimen shall be held at that pressure out sufficiently to produce leakage of air, the temperature of the bath shall be recorded as the yield temperature of the plugs. As an alternate method, the plugs, after passing the tests at a temperature of not less than 5° F below the specified minimum yield temperature, shall be held at that temperature for five minutes. If air leakage occurs within five minutes at that temperature, the requirements have been met.
1.4.1	Fusible Alloy shall conform to the following: COMPOUNDS: PROPORTIONS: TOLERANCES IN ANALYSIS OF FINISHED ALLOY: Bismuth 50.51 parts by weight Cadmium 27.51 " " Tin 12.18 " " Zinc 9.28 " " The yield temperature, i.e. melting point shall be between 158° F and 165° F	3.2.3.1	Variation in temperature within the liquid bath in which the plug is held shall be not in excess of 3.2° F or 3.2° C shall be kept to a minimum by stirring while making these tests. RECONDITIONED VALVES (See CI Pamphlet 17)
1.4.2	Test of Fusible Alloy	4.0	
1.4.3	To determine the yield temperature, the following test on the alloy shall be conducted: Select at random two sticks of the fusible alloy from each batch. A sample for the test shall consist of a piece 2" long by approximately 1/4" diameter cut from each stick. Each sample shall be placed horizontally on suitable supports spaced 1" apart and presenting the sharp ends of the sticks to the top of the bath. The supports shall be in a glycerine bath not closer than 1/4" to the bottom of the container. This bath temperature shall be raised at a rate not in excess of 5° per minute. Two samples from the same stick shall be tested at one time. A temperature measuring device shall be inserted into the bath between and closely adjacent to the sample so that the sensor will be completely immersed at the same level as the samples. The bath temperature shall be raised at a rate not in excess of 5° F per minute. The yield temperature shall be taken as that temperature at which the second end of each sample loses its rigidity and droops. Bars shall be free cutting brass rod, half hard, conforming to ASTM B 164, Copper Alloy C38000	3.2.3.3	
1.4.3.1			
1.4.3.1.1			
1.4.3.1.2			
1.4.3.1.3			
1.5	Material shall conform to ASTM B 164 (Class A or B)		
1.6	RESERVED		
1.7	RESERVED		
1.8	Geckels shall conform to CI Drawing 184.		

THIS DRAWING WAS DEVELOPED BY A TECHNICAL COMMITTEE OF THE INSTITUTE. THE USER SHOULD BE AWARE THAT CHANGING TECHNOLOGY OR REGULATIONS MIGHT REQUIRE REVISION OF THE DRAWING. PLEASE CONTACT THE INSTITUTE TO BE KEPT ADVISED OF ANY SUCH REVISIONS.

9	18-60	REVISED 1.1.2, ADD 1.2.3
8	12-68	REDRAWN
7	3-60	
6	9-78	
5	1-68	
4	6-60	
3	1-61	
1	10-58	INITIAL RELEASE
		REVISION

THE CHLORINE INSTITUTE, INC.  
WASHINGTON, D.C.

**VALVE & FUSIBLE PLUG FOR CHLORINE CYLINDERS & TON CONTAINERS MATERIALS & TEST SPECS.**

DRAWN	A. KASS	2-93
CHECKED	MEL	
APPROVED		
D.L.C. NO.	<b>112</b>	ISSUE <b>9</b>

DRAWING 113-8: VALVE DETAILS FOR CHLORINE CYLINDERS AND TON CONTAINERS

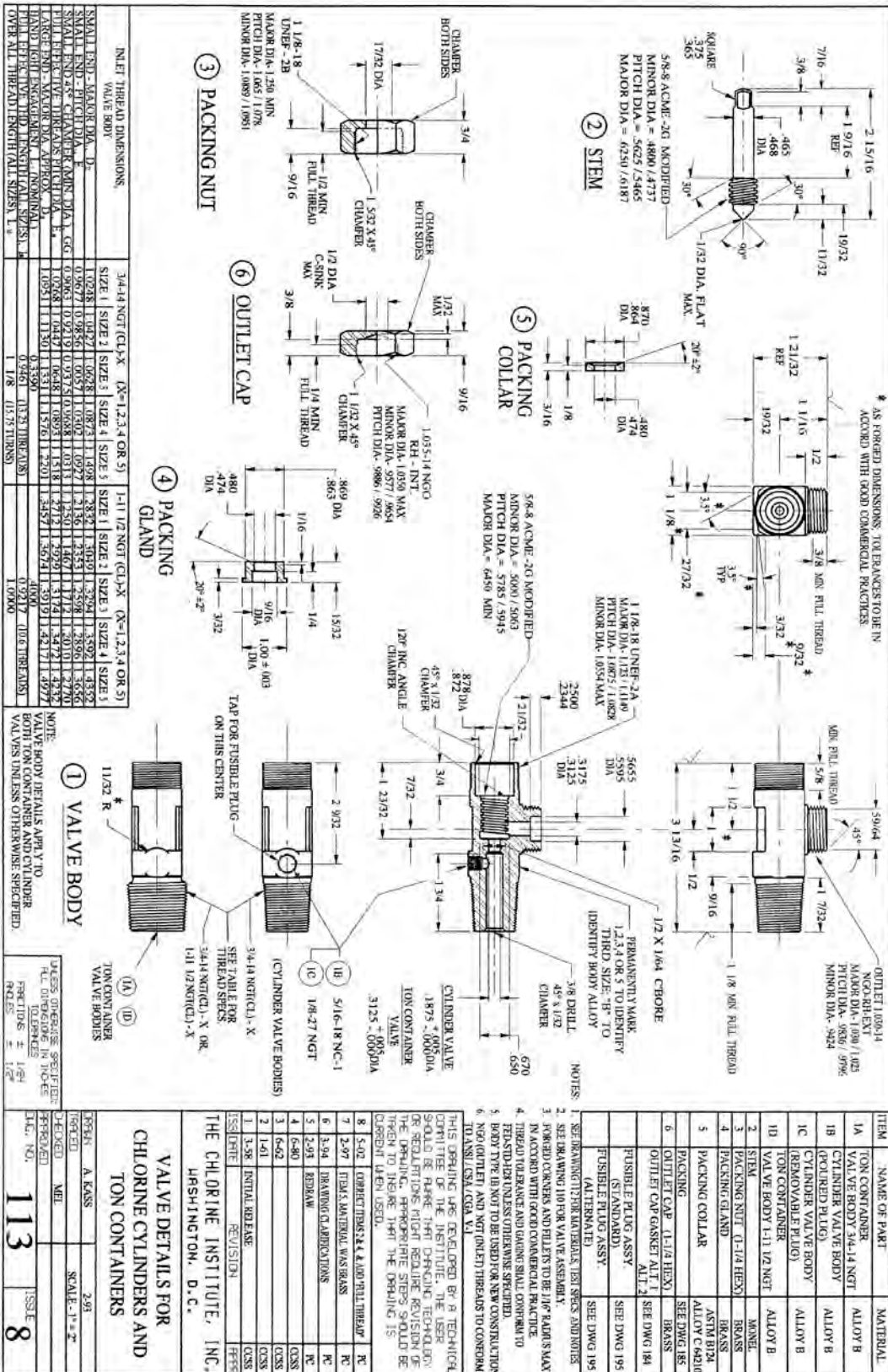

DRAWING 114-6: EXCESS FLOW VALVE WITH REMOVABLE SEAT

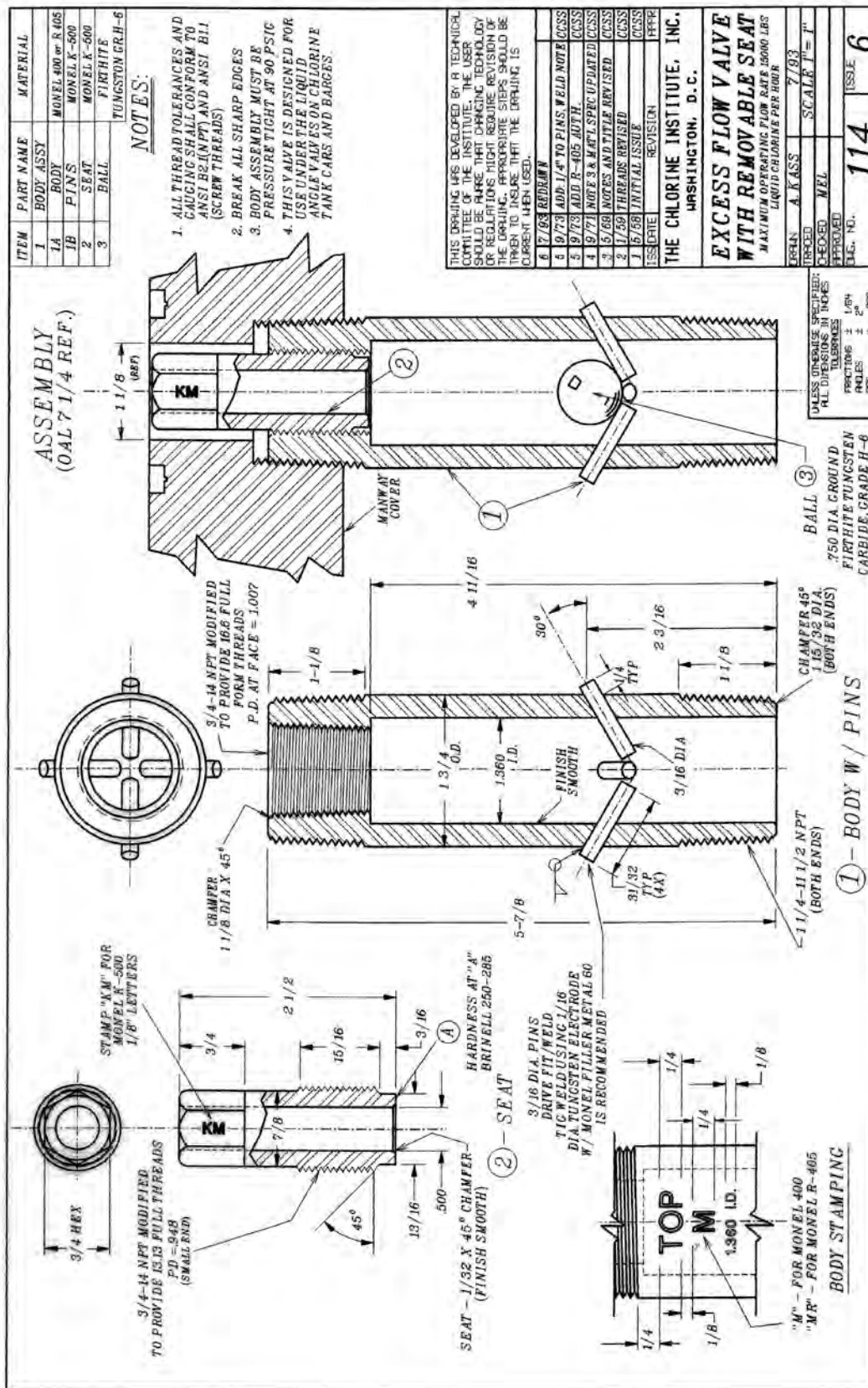

ITEM	PART NAME	MATERIAL
1	BODY ASSY	
1A	BODY	MONEL 400 or R 405
1B	PINS	MONEL K-500
2	SEAT	MONEL K-500
3	BALL	FIRHITE TUNGSTON GRH-6

- NOTES:**
1. ALL THREAD TOLERANCES AND GAUGING SHALL CONFORM TO ANSI B2.1 (NPT) AND ANSI B1.1 (SCREW THREADS)
  2. BREAK ALL SHARP EDGES
  3. BODY ASSEMBLY MUST BE PRESSURE TIGHT AT 90 PSIC
  4. THIS VALVE IS DESIGNED FOR USE UNDER THE LIQUID ANGLE VALVES ON CHLORINE TANK CARS AND BARGES.

THIS DRAWING WAS DEVELOPED BY A TECHNICAL COMMITTEE OF THE INSTITUTE. THE USER OF THIS DRAWING SHALL BE RESPONSIBLE FOR THE DESIGN AND CONSTRUCTION OF THE DRAWING. APPROPRIATE STEPS SHOULD BE TAKEN TO INSURE THAT THE DRAWING IS CURRENT WHEN USED.

6 17/88	REDRAWN	
6 9/73	ADD 1/4" TO PINS, WELD NOTE	CCSS
5 19/73	ADD R-405 AUTH.	CCSS
4 19/71	NOTE 3 & M.T. SPEC UPDATED	CCSS
3 5/68	NOTES AND TITLE REVISED	CCSS
2 1/58	THREADS REVISED	CCSS
1 1/56	INITIAL ISSUE	CCSS
ISS DATE	REVISION	PPPE

THE CHLORINE INSTITUTE, INC.  
WASHINGTON, D. C.

**EXCESS FLOW VALVE WITH REMOVABLE SEAT**  
MAXIMUM OPERATING FLOW RATE 16000 LBS LIQUID CHLORINE PER HOUR

DESIGN	A. KASS	7/53
DRAWN	MEL	
CHECKED	MEL	
APPROVED		
SCALE	1" = 1"	
FIG. NO.	114	ISSUE 6

**DRAWING 118-5: CHLORINE TANK CAR UNLOADING CONNECTION**

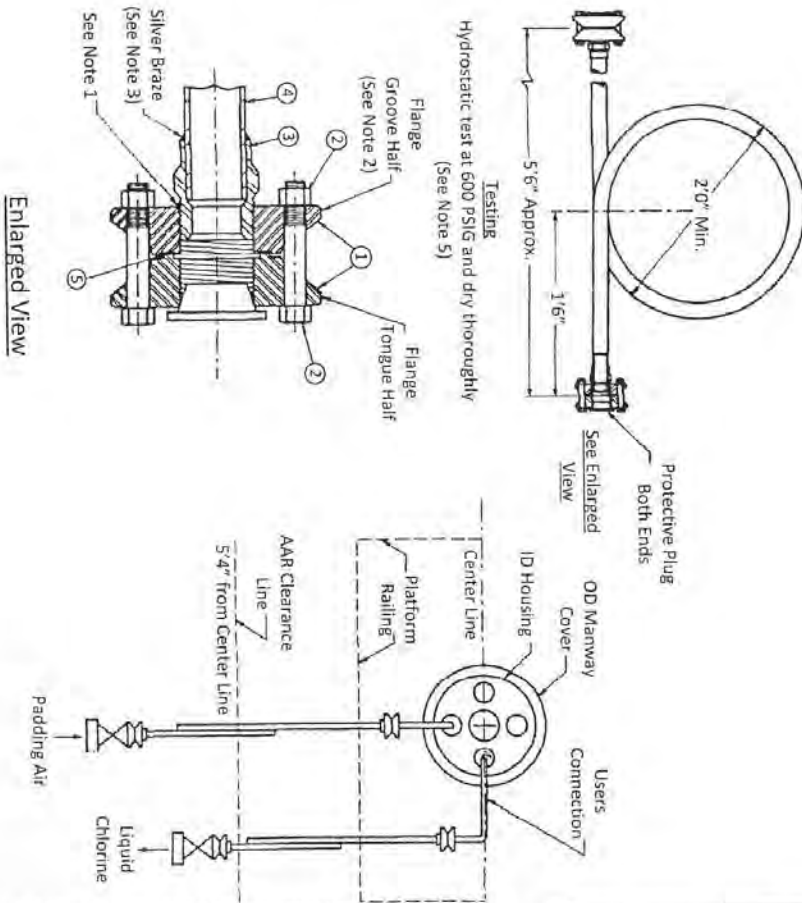

Item	Name of Part	Material
1	Two bolt oval flanged union type 1500H 1" NPT FEM TH.D (Note 4)	Forged ST. ASTM A 105
2	Bolts & nuts, HYV Hex, Bolts per ANSI B 18.2.1 Nuts per ANSI B 18.2.2 Threads per ANSI B 1.1 Class 24 & 2B fit, Bolt Dia. & length to suit flanges	Carbon ST. ASTM A 307 Grade B
3	Adapter, solder joint, Per ANSI B 16.22; 1 1/8 OD tube to 1" NPT Male or suitable material	Wrought Copper ASTM B 75 or see "Hose" section in Pamphlet 6 for other suitable options
4	Tubing type K, Annealed Size per ANSI H 23.1 (1 1/8 OD x .065 W all) or suitable hose material	Copper ASTM B 88 or see "Hose" section in Pamphlet 6 for other suitable options
5	Gasket, asbestos composition or 2% to 4% antimony lead. Dimensions to suit flanges	Asbestos Per Fed. Spec. HH - P46E Lead Per ASTM B 29

**Notes:**

1. Use Itharge and Glycerine or white lead paste on pipe threads.
2. Assemble the groove half of the flange to the adapter - both ends.
3. Silver bronze - full penetration required, brazing alloy must have a minimum silver content of 44% and must be tin-free. Please see "Nonferrous Metal" section in Pamphlet 6.
4. Alternate - 300# large tongue and groove flanges per ASME B16.5 may be used.
5. Max design working pressure is 400PSI.

This drawing was developed by a technical committee of the Institute. The user should be aware that changing technology or regulations might require revision of the drawing. Appropriate steps should be taken to insure that the drawing is current when used.

The Chlorine Institute Arlington, VA	
6	12/12 Redraw, Rev. Notes
5	11/91 Redraw
4	2/85 Rev. notes, B/M & details
3	9/77 Update B/M, del, details
2	5/61 Initial release
1	Date

Chlorine Tank Car Unloading Connection	
Draw	A. KASS
Traced	
Checked	Rep
Approved	
DWG. No.	118
Issue	5

Unless otherwise specified: ALL dimensions in inches.

Tolerances:  
 Fractions ± 1/64  
 Angles ± 2"  
 Dec. ± .003

DRAWING 130-5: STANDARD CHLORINE CYLINDER AND TON CONTAINER VALVE YOKE ADAPTERS

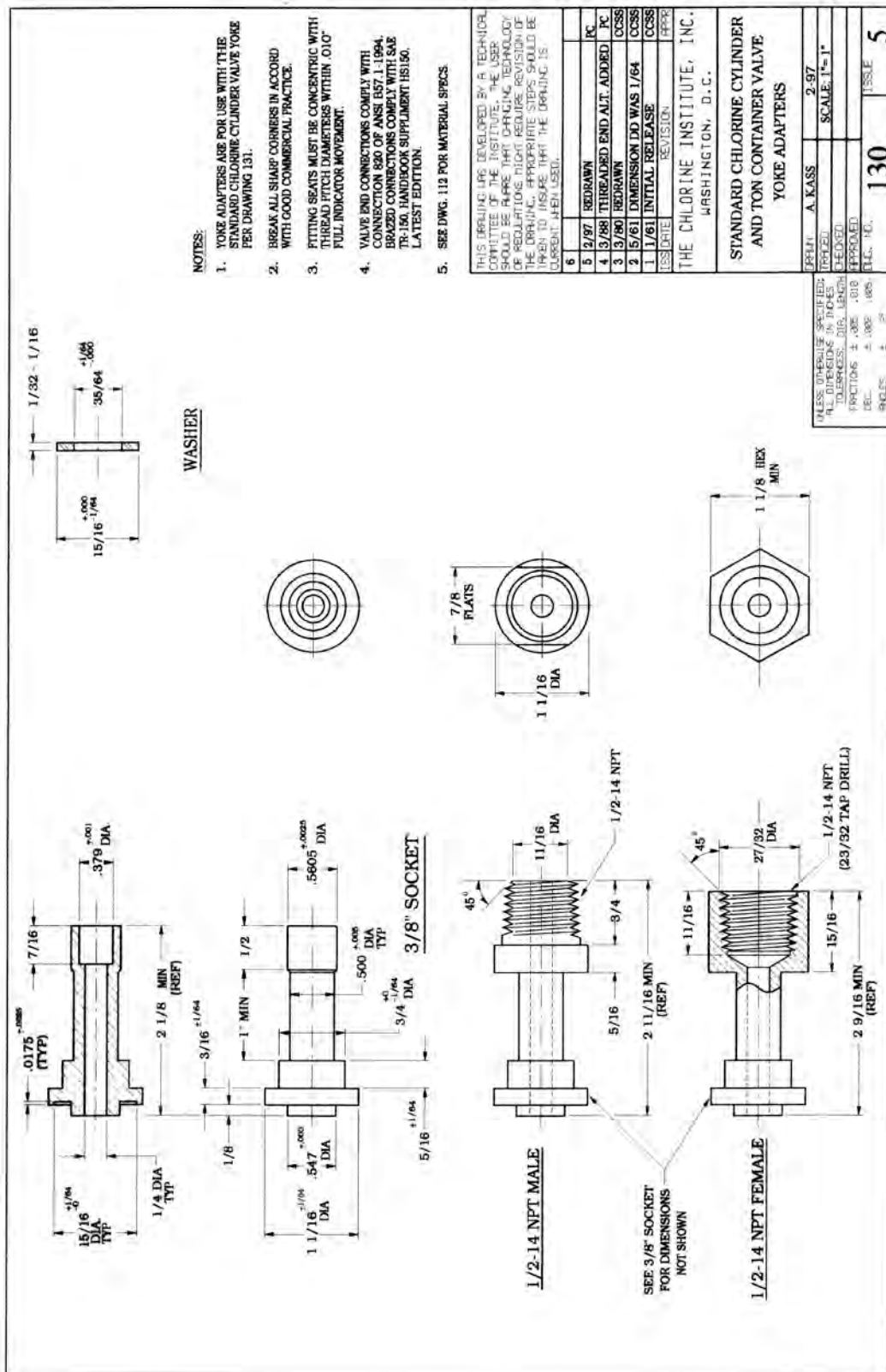

DRAWING 131-4: CHLORINE CYLINDER VALVE YOKE

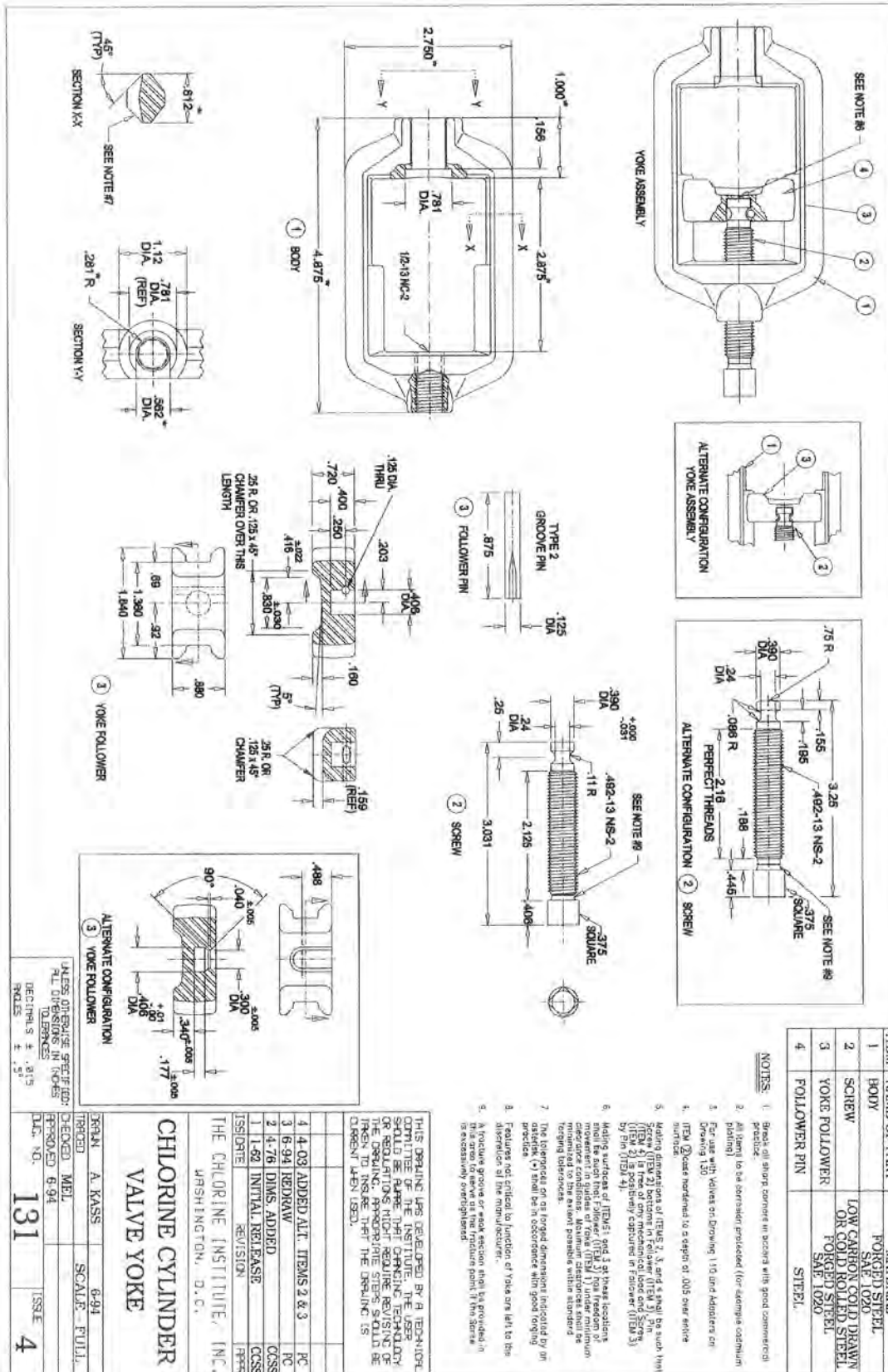



**DRAWING 136-8: CHLORINE EXPANSION CHAMBERS**

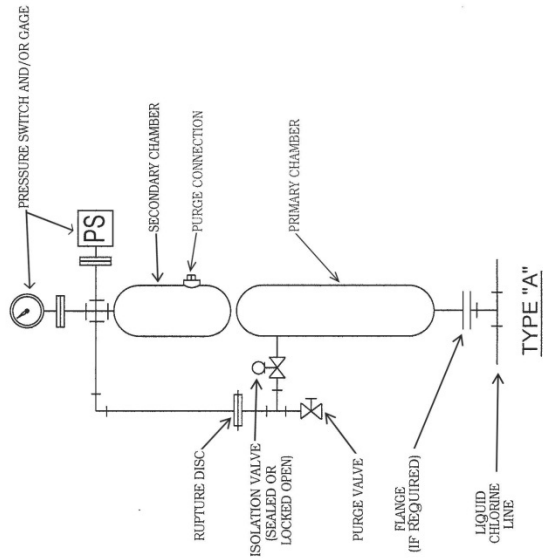
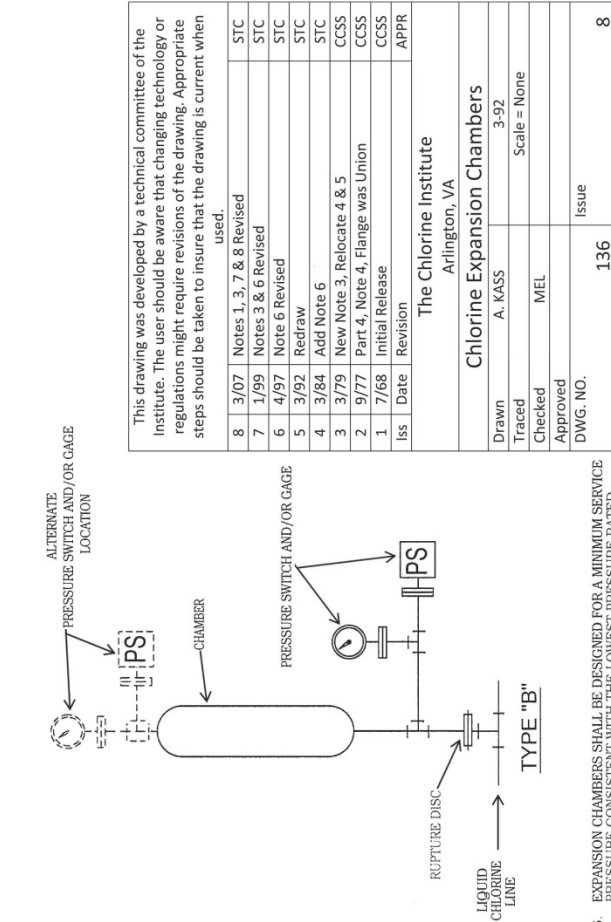

This drawing was developed by a technical committee of the Institute. The user should be aware that changing technology or regulations might require revisions of the drawing. Appropriate steps should be taken to insure that the drawing is current when used.

8	3/07	Notes 1, 3, 7 & 8 Revised	STC
7	1/99	Notes 3 & 6 Revised	STC
6	4/97	Note 6 Revised	STC
5	3/92	Redraw	STC
4	3/84	Add Note 6	STC
3	3/79	New Note 3, Relocate 4 & 5	CCSS
2	9/77	Part 4, Note 4, Flange was Union	CCSS
1	7/68	Initial Release	CCSS
Iss	Date	Revision	APPR

The Chlorine Institute Arlington, VA	
Drawn	A. KASS
Traced	3-92
Checked	MEL
Approved	
DWG. NO.	136
Issue	8

**NOTES:**

- EXPANSION CHAMBERS SHOULD BE INSTALLED WHERE THERE IS A POSSIBILITY THAT LIQUID CHLORINE WILL BE TRAPPED BETWEEN TWO CLOSED LIQUID LINE VALVES AND THE SYSTEM LEFT UNATTENDED AFTER VALVE CLOSURE. THESE RECOMMENDATIONS ARE BASED ON THERMAL EXPANSION OF LIQUID CHLORINE BETWEEN 0°F (-18°C) AND 140°F (60°C).
- CHAMBER CAPACITIES:  
TYPE "A" - PRIMARY (BOTTOM) - 20% OF LIQUID CHLORINE LINE VOLUME  
SECONDARY (TOP) - 10% OF LIQUID CHLORINE LINE VOLUME  
TYPE "B" - ONE TANK - MINIMUM OF 20% OF LIQUID CHLORINE LINE VOLUME
- FOR AN ANSI CLASS 300 RATED SYSTEM @ 300F THE PRESSURE RATING OF THE SYSTEM IS 655 PSIG. PAST INDUSTRIAL PRACTICE IS TO USE A 400 PSIG RUPTURE DISK WHICH IS SUITABLE FOR MANY SYSTEMS. SETTING MUST COMPLY WITH NOTE 6A.
- PRESSURE GAGES AND SWITCHES SHALL CONFORM TO C.I. PAMPHLET #6.
- PIPING AND CRITERIA FOR INSTALLATION SHALL CONFORM TO C.I. PAMPHLET #6.
- EXPANSION CHAMBERS SHALL BE DESIGNED FOR A MINIMUM SERVICE PRESSURE CONSISTENT WITH THE LOWEST PRESSURE RATED COMPONENT OF THE SYSTEM AND SHALL BE CONSTRUCTED:  
A. FROM PIPE AND FITTINGS IN ACCORD WITH C.I. PAMPHLET 6, or DEPARTMENT OF TRANSPORTATION OR TRANSPORT CANADA SPECIFICATION (WITH A MINIMUM SERVICE PRESSURE RATING OF 480 PSIG (3309kPa)); or  
B. FROM SEAMLESS, DRAWN CYLINDER IN ACCORD WITH U.S. DEPARTMENT OF TRANSPORTATION OR TRANSPORT CANADA SPECIFICATION (WITH A MINIMUM SERVICE PRESSURE RATING OF 480 PSIG (3309kPa)); or  
C. PER ASME CODE SECTION VIII.
- CHAMBERS SHOULD BE PROPERLY SUPPORTED.
- TYPE "A" IS NORMALLY USED IN ORDER TO ALLOW THE RUPTURE DISC TO BE REPLACED WITHOUT SHUTDOWN OF THE PIPELINE. THE TYPE "B" IS NORMALLY USED IN ORDER TO ALLOW THE RUPTURE DISC TO BE REPLACED WITHOUT SHUTDOWN OF THE ENTIRE PIPELINE. THE TYPE "B" SYSTEM TO PREPARE FOR REPLACING THE RUPTURE DISC, PURGE THE PRIMARY CHAMBER, CONNECT DRY AIR OR NITROGEN TO THE PURGE VALVE AND THEN OPEN THE ISOLATION VALVE AND THE ISOLATION VALVE. THEN CLOSE THE ISOLATION VALVE TO ENSURE THE PIPELINE HAS THERMAL EXPANSION PROTECTION WHILE THE SECONDARY CHAMBER IS COMPLETELY OPENING, THE PURGE VALVE WHILE THE ISOLATION VALVE IS CLOSED, DISCHARGE MUST BE TO A SUITABLE SAFE PLACE. THE ISOLATION VALVE MUST BE LOCKED OR SEALED OPEN DURING OPERATION WITH VISUAL INDICATION OF VALVE POSITION TO ASSURE SYSTEM OVER-PRESSURE PROTECTION BY THE RUPTURE DISC.

Unless otherwise specified: All dimensions in inches

Fractions	±	Tolerances
Angles	±	$\frac{1}{16}$
Dec.	±	2°
		.003

**DRAWING 162-4: EXCESS FLOW VALVE WITH REMOVABLE SEAT**

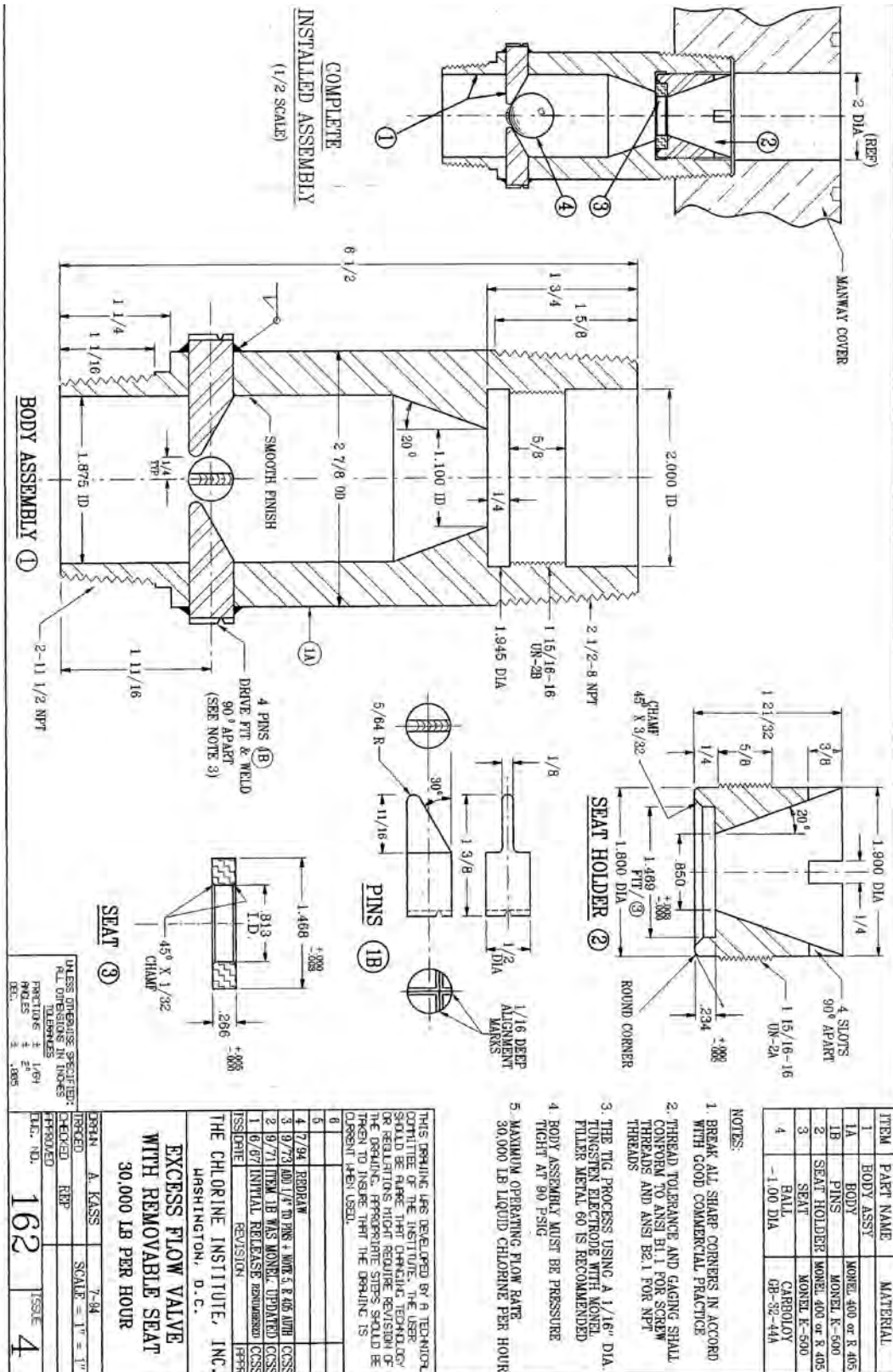

ITEM	PART NAME	MATERIAL
1	BODY ASSY	
1A	BODY	MONEL 400 or R 405
1B	PINS	MONEL K-500
2	SEAT HOLDER	MONEL 400 or R 405
3	SEAT	MONEL K-500
4	BALL	CARBOLLOY CR-52-44A

**NOTES:**

1. BREAK ALL SHARP CORNERS IN ACCORD WITH GOOD COMMERCIAL PRACTICE.
2. THREAD TOLERANCE AND GAGING SHALL CONFORM TO ANSI B1.1 FOR SCREW THREADS AND ANSI B2.1 FOR NPT THREADS.
3. THE TIG PROCESS USING A 1/16" DIA TUNGSTEN ELECTRODE WITH MONEL FILLER METAL 60 IS RECOMMENDED.
4. BODY ASSEMBLY MUST BE PRESSURE TIGHT AT 90 PSIG.
5. MAXIMUM OPERATING FLOW RATE 30,000 LB LIQUID CHLORINE PER HOUR.

THIS DRAWING WAS DEVELOPED BY A TECHNICIAN EMPLOYEE OF THE INSTITUTE. THE USER SHOULD BE AWARE THAT CHANGING TECHNOLOGY OR REGULATIONS MIGHT REQUIRE REVISION OF THE DRAWING. APPROPRIATE STEPS SHOULD BE TAKEN TO INSURE THAT THE DRAWING IS CURRENT WHEN USED.

NO.	DATE	DESCRIPTION	BY	CHKD
4	2/84	REBORN		
3	9/73	ADD 1/4" TO NPT & R 405 TUN		
2	9/71	ADD 1B WAS MONEL (UPDATED)		
1	6/67	INITIAL RELEASE (RECOMMENDED)		

THE CHLORINE INSTITUTE, INC.  
WASHINGTON, D.C.

**EXCESS FLOW VALVE WITH REMOVABLE SEAT**  
30,000 LB PER HOUR

DESIGN: A. KASS  
CHECKED: RRP  
SCALE: 1" = 1"  
TIT. NO. **162** SCALE **4**

**DRAWING 171-3: SMALL UNION CONNECTION**

Item	Name of Part	Material
1	Union Nut	Refer to Pamphlet 6 for suitable materials
2	Union Nipple	Refer to Pamphlet 95 for suitable materials
3	Gasket	Refer to Pamphlet 6 for suitable materials
4A	Plug	Refer to Pamphlet 6 for suitable materials
4B	Adapter	Refer to Pamphlet 6 for suitable materials
4C	Tube End	Refer to Pamphlet 6 for suitable materials

**Note:**

1. Thread tolerances and gaging shall conform to ANSI B1.1 for screw threads and ANSI B2.1 for NPT threads.
2. Break all sharp edges

This drawing was developed by a technical committee of the Institute. The user should be aware that changing technology or regulations might require revision of the drawing. Appropriate steps should be taken to insure that the drawing is current when used.

6			
5			
4	1/13	Revised Material of Construction Guidance	
3	7/94	Redrawn	
2	5/74	Initial Release	CCSS
1		Revision	APPR
The Chlorine Institute Arlington, VA			
Small Union Connection			
Drawn A. Kass		7-94	
Traced		Scale - 2X	
Checked MEL			
Approved			
OWG. NO.	171	Issue	3

Unless Otherwise Specified, All Dimensions in Inches

Tolerances	
Fractions	± 1/32
Angles	± 2'
Dec. XXX	± .003
Dec. XX	± .015
Dec. X	± .030
Fractions	± 1/16

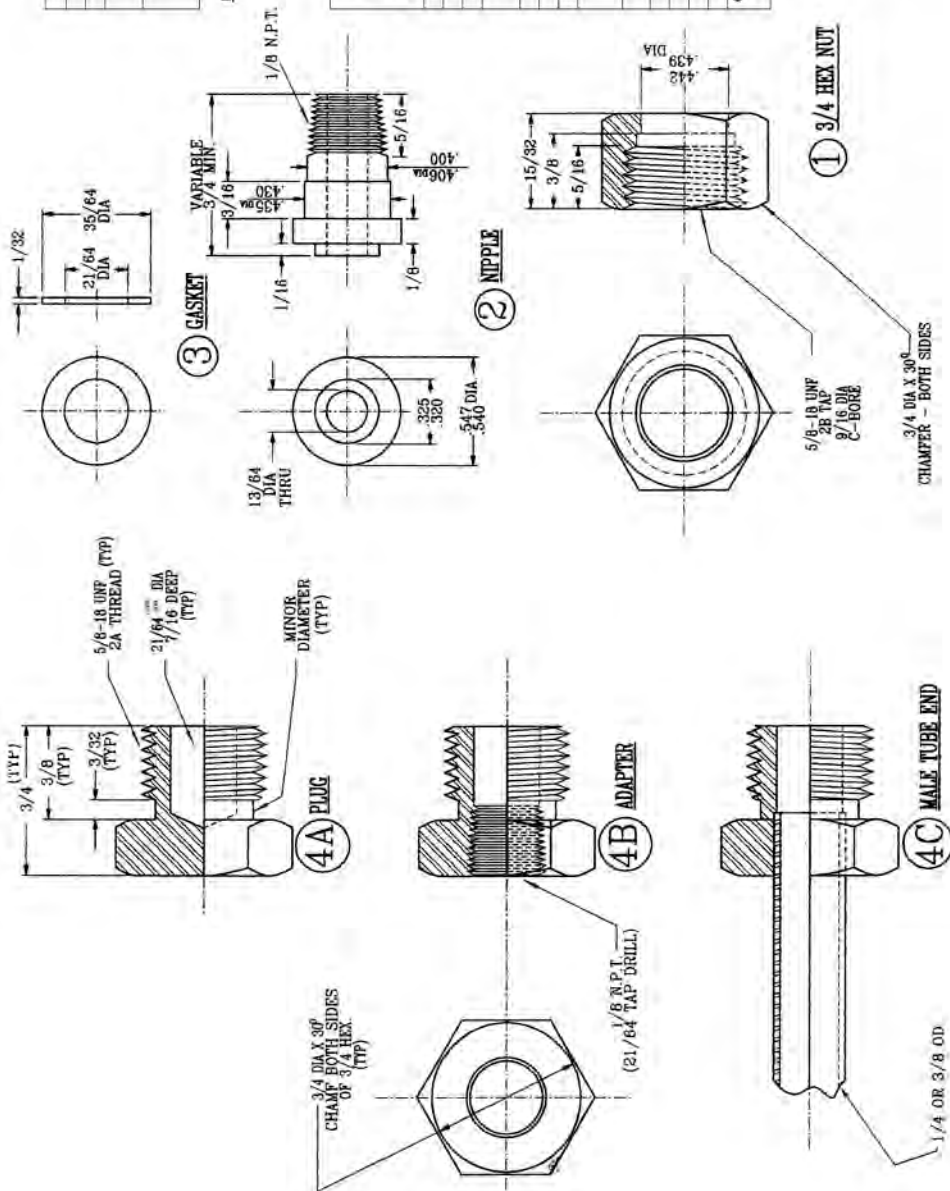

**DRAWING 189-2: CLOSED YOKE CHLORINE CONTAINER VALVE**

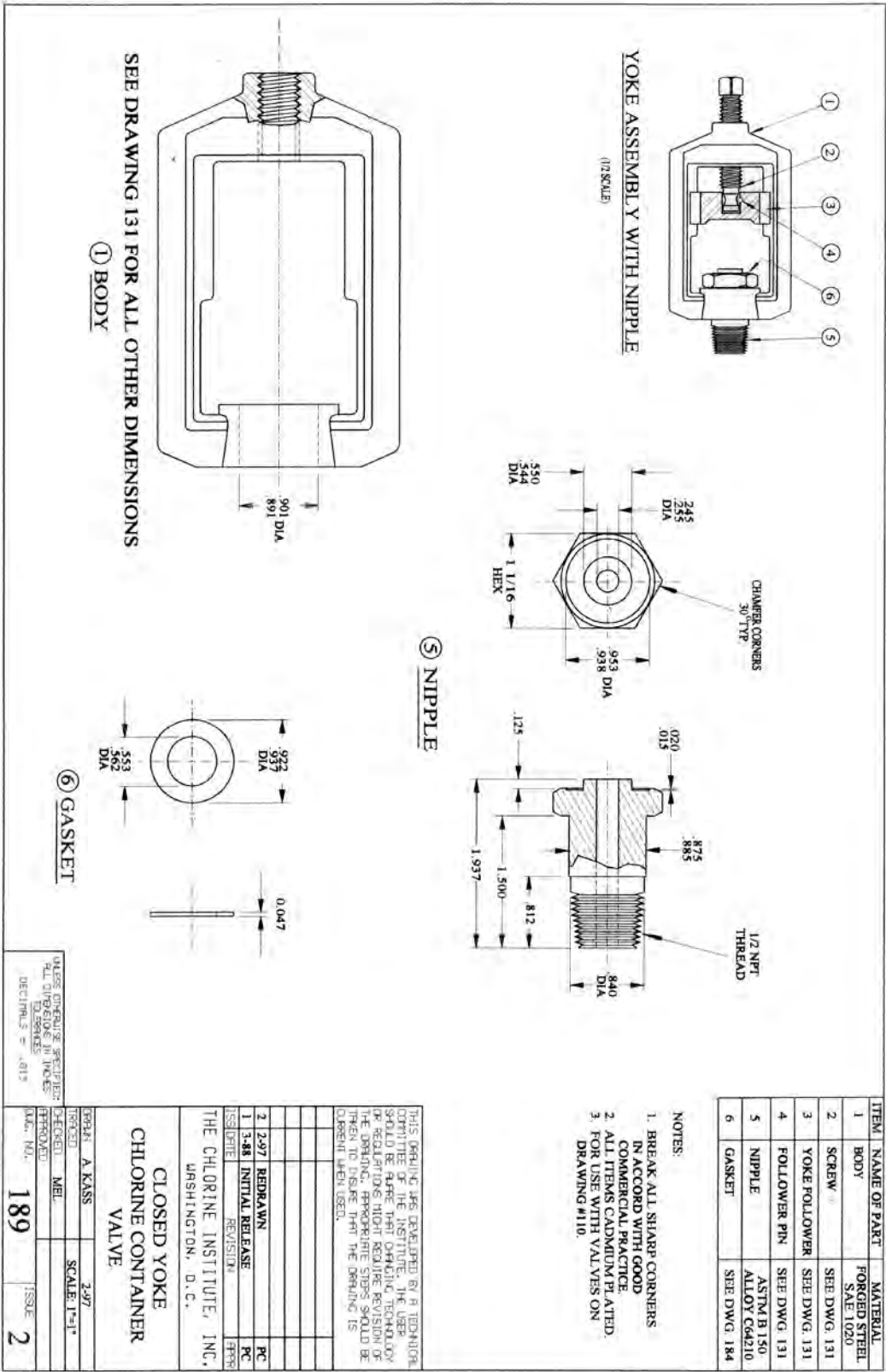



1300 Wilson Boulevard « Suite 525 « Arlington, VA 22209  
Telephone: (703) 894-4140 « Fax: (703) 894-4130  
Email: [pubs@CL2.com](mailto:pubs@CL2.com) « Website: [www.chlorineinstitute.org](http://www.chlorineinstitute.org)  
Technical inquiries: [techsvc@cl2.com](mailto:techsvc@cl2.com)

---

©The Chlorine Institute all rights reserved.