

RADtec Radiant Heat Panel

THE HEAT IS ON



OWNER'S MANUAL

READ AND SAVE THESE INSTRUCTIONS

- *Read all instructions carefully before setting up and operating this unit.*
- *This manual is designed to provide you with the information needed to set up, operate, and maintain your radiant heater.*
- *Failure to follow these instructions may damage and / or impair its operation.*

**. BLANK PAGE
. FOR NOTES**

1. INTRODUCTION

Thank you for your trust and support in choosing the eRAD, Radiant Heater. Please read the instructions carefully before operating this product.

You have purchased one of the most advanced heating systems for indoor and covered outdoor areas. The infrared radiant heater is characterized by a focused distribution of heat, which transports heat evenly to where it is needed.

Keep these instructions for future reference and make sure to pass on the operating instructions to any subsequent owner of the unit and ensure that any supplements received are included with the instructions.

2. HOW FAR-INFRARED HEATING WORKS

At RADtec, our far-infrared radiant heaters' energy output is best compared to the warmth of the sun. To be more specific, our heaters operate just outside of "visible light" on the electromagnetic spectrum. Infrared light has the lowest frequency of all and therefore also the lowest energy level. Because of its wavelength, far-infrared "light" waves pass through the air, traveling around air molecules with virtually no ability to collide with and "excite" (heat) them. Instead, far infrared waves collide with the surfaces they encounter, gradually warming the surface (people/objects) within the space. It is what makes infrared heating the most efficient and healthiest way to heat any indoor or outdoor living space.

eRAD is the choice in electric radiant heaters for your outdoor or indoor areas

Our far-infrared radiant heaters are produced through our unique design and manufacturing techniques. When finished, this production process delivers our unique aluminum alloy radiant panels. We at RADtec refer to this as "slimline" technology. The surface of each panel is prepared with a special coating. Inside, each heater is an embedded heating element. When supplied with electrical power (turned on), this heating element generates and transfers heat to people and objects.

3. PRODUCT OVERVIEW

Discrete, stylish heating for outdoor and indoor areas

eRAD heaters can provide effective and energy efficient comfort heating for outdoor and indoor areas. eRAD heaters have successfully enabled many entertainment venues such as restaurants, pubs, and clubs to utilize their outdoor dining areas day and night, all year long. Within your workplace or business, eRAD can provide heating for designated outdoor smoking and leisure areas, as well as for workstation spot heating in factories, warehouses, and showrooms. Within your home, eRAD can provide comfort heating for covered alfresco dining and BBQ areas, patios, verandas, courtyards, and balconies.

Subtle, Slimline, No-Glow design

The stylish, slimline black face of the eRAD radiant heater does not emit light or glow when in use, blending elegantly into your décor. Ceiling and wall mounting options ensure that your valuable floor, lounge and table space is not wasted.

Efficient cost-effective electric heating

The innovative design of the eRAD radiant heater enables comfortable and even heat dispersion from the surfaces with minimal operating costs.

Design flexibility

Four eRAD models are available, ensuring the heating requirements of any outdoor or indoor area is possible. Brackets for direct ceiling/wall mounting are supplied with the unit.

Virtually maintenance-free

The eRAD radiant heater incorporates no internal moving parts, ensuring quiet and virtually maintenance-free operation.

Easy to use

The standard eRAD radiant heater is controlled with a simple on/off operation, and is either plugged directly into a power supply, or hard-wired via a wall mounted on/off switch. The unit takes approximately 10 minutes to heat up to maximum temperature and about 30 minutes to cool down, depending upon the ambient temperature. The higher end units come supplied with a remote control and a timed automatic shut-off function, giving you the convenience of remote operation.

Environmentally Friendly

eRAD radiant heaters have no byproducts such as carbon or gas while operating.

4. PERFORMANCE FEATURES

Coverage Area Table

Model No.	Indoors	Outdoor Enclosed	Outdoor Exposed
<i>eRAD10R</i>	30ft ² ~ 2.8m ²	25ft ² ~ 2.3m ²	20ft ² ~ 1.9m ²
<i>eRAD15R</i>	50ft ² ~ 4.6m ²	40ft ² ~ 3.7m ²	30ft ² ~ 2.8m ²
<i>eRAD18R</i>	50ft ² ~ 4.6m ²	40ft ² ~ 3.7m ²	30ft ² ~ 2.8m ²
<i>eRAD24R</i>	80ft ² ~ 7.4m ²	65ft ² ~ 6m ²	50ft ² ~ 4.6m ²
<i>eRAD32R</i>	110ft ² ~ 10.2m ²	90ft ² ~ 8.4m ²	70ft ² ~ 6.5m ²

Comfortable:

No wind, light or odor produced while operating this product. Indoor air remains free of floating dust or allergens as a result.

Energy-Saving:

Heat generated efficiently with low-power input. Controlling temperature in this manner allows you to save power and energy. Heating elements have a useful life of at least 30,000 hours of operation.

Physical Therapy:

Heat therapy is most commonly used for rehabilitation purposes. The therapeutic effects of heat include increasing the extensibility of collagen tissues; decreasing joint stiffness; reducing pain; relieving muscle spasms; reducing inflammation and increasing blood flow. The increased blood flow to the affected area provides proteins, nutrients, and oxygen for better healing. Infrared heating technology is a convenient way to heat parts of our body. It has the advantage over direct contact in that radiant energy can heat directly the area where the blood capillaries and neuron terminals are. When the heat comes from a direct contact source, it has to heat the external layer of the skin, and heat is transferred to the deeper layer by conduction.

5. OPERATING CONDITIONS

Ambient (surrounding) Temperature:

- 35°F ~ 65°F

Rated Voltage:

- 220-240V (eRAD18R, eRAD24R, eRAD32R);
- 110-120V (eRAD15R, eRAD10R)

Rated Frequency: 50Hz/60Hz

Relative Humidity: less than 95%

6. INSTALLATION REQUIREMENTS

1. Qualified Installer:

A licensed electrician should be consulted for installation, and electrical installation should be made in accordance with the national electrical code.

2. Installation Conditions:

- a. Before starting the installation, you must ensure that the operating voltage corresponds to that stated on the eRAD specifications label located on the side-panel of the heater. Supply Voltage fluctuation range should be within $\pm 10\%$. If condition not met, it must be resolved before installation
- b. If there is a severe security risk in users' electricity environment, the installation should be halted until the security risks are eliminated.
- c. Power lines should be equipped with earth/water leakage protection devices and a master switch.
- d. The ground wire needs to be connected to the grounding device in the building. If not, please consult with a professional installer. DO NOT put ground wire to/near a gas pipe, water pipe, lightning rod or telephone grounding wire.
- e. eRADusa recommends an installation height of no less than 7.22ft (2.2m) above the ground.
- f. Never locate the heater where it may fall into a bathtub, pool, spa, or other wet area.

Electrical Parameters Table

Model No.	Wattage(W)	Amperage(A)	Voltage(V)	Wire Length(in)
<i>eRAD10R</i>	1000	4.3	110-120	78.74
<i>eRAD15R</i>	1500	13.6	110-120	78.74
<i>eRAD18R</i>	1800	7.8	220-240	78.74
<i>eRAD24R</i>	2400	10.4	220-240	78.74
<i>eRAD32R</i>	3200	13.9	220-240	78.74

7. INSTALLATION INSTRUCTIONS

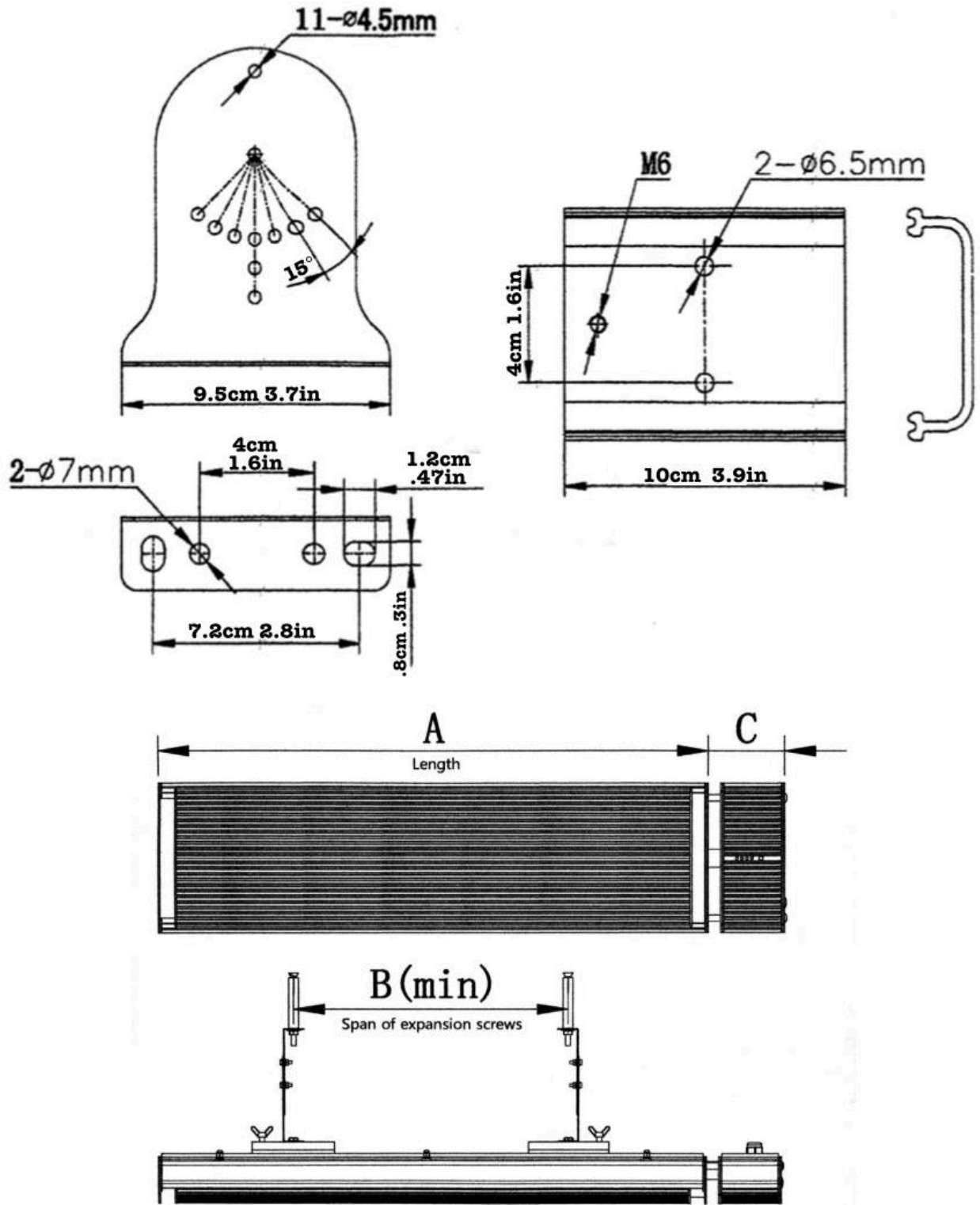

Model No.	Dimension A (in)	Dimension B (in)	Dimension C (in)
<i>eRAD10R</i>	26.3	7.9	3.74
<i>eRAD15R</i>	42.3	27.6	3.74
<i>eRAD18R</i>	42.3	27.6	3.74
<i>eRAD24R</i>	61.3	47.2	3.74
<i>eRAD32R</i>	81.3	66.9	3.74

Step 1: Remove packing materials from both ends of heater.



Step 2: Installation of adjusting bracket and sliding bracket.

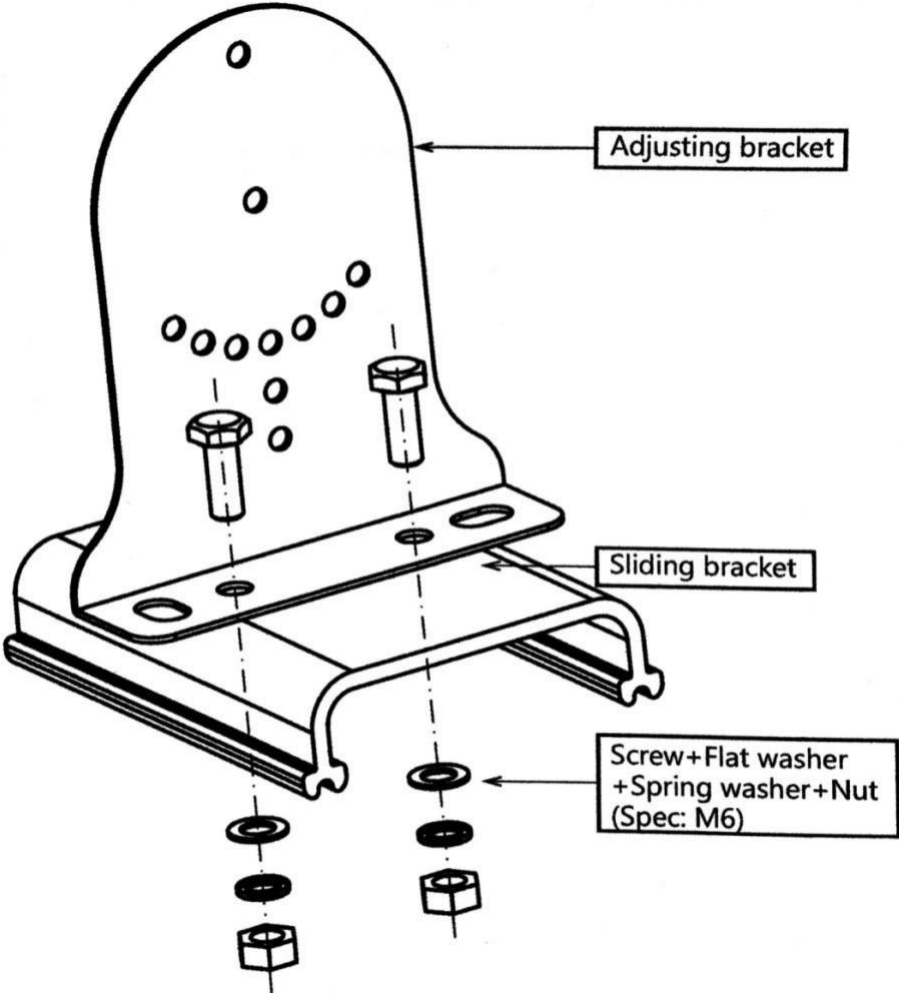

Step 3: Installation of sliding bracket and heater, as arrow points.

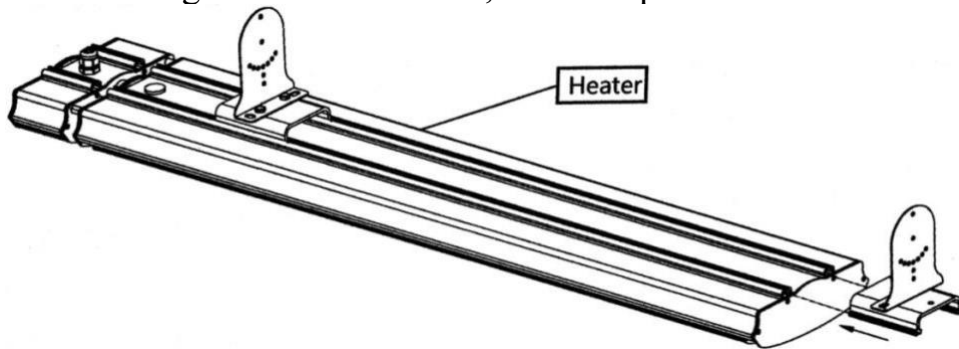

Step 4: Fix adjusting bracket into wall with expansion screws.

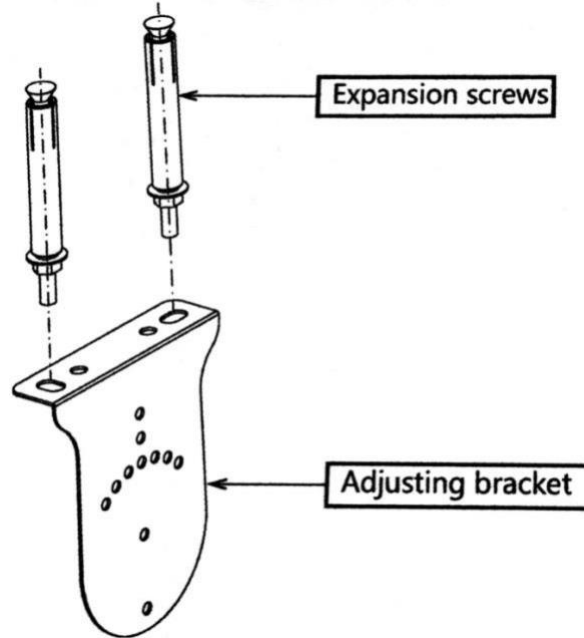

Step 5: Installation of two adjusting brackets. Make sure to lock brackets tightly by using the butterfly hand screw.

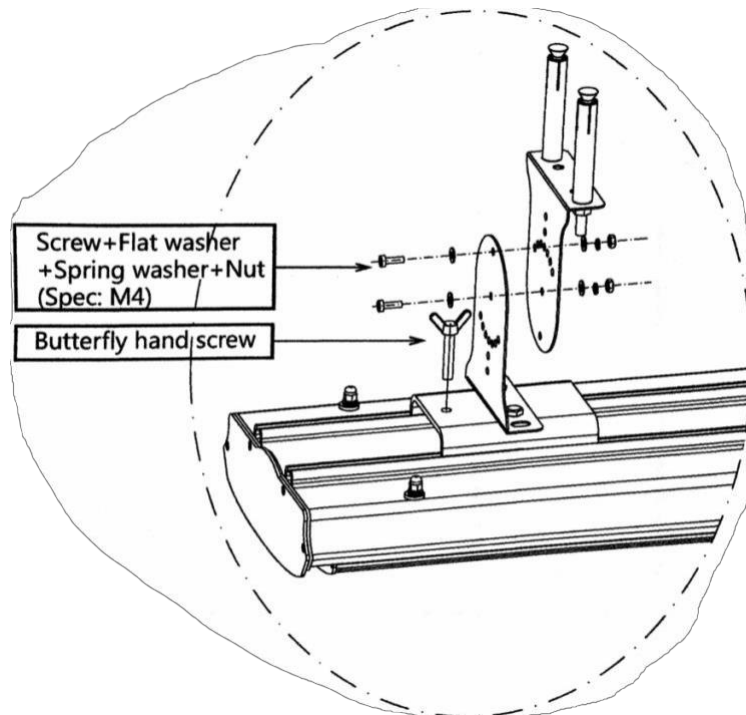

8. INSTALLATION DIAGRAM

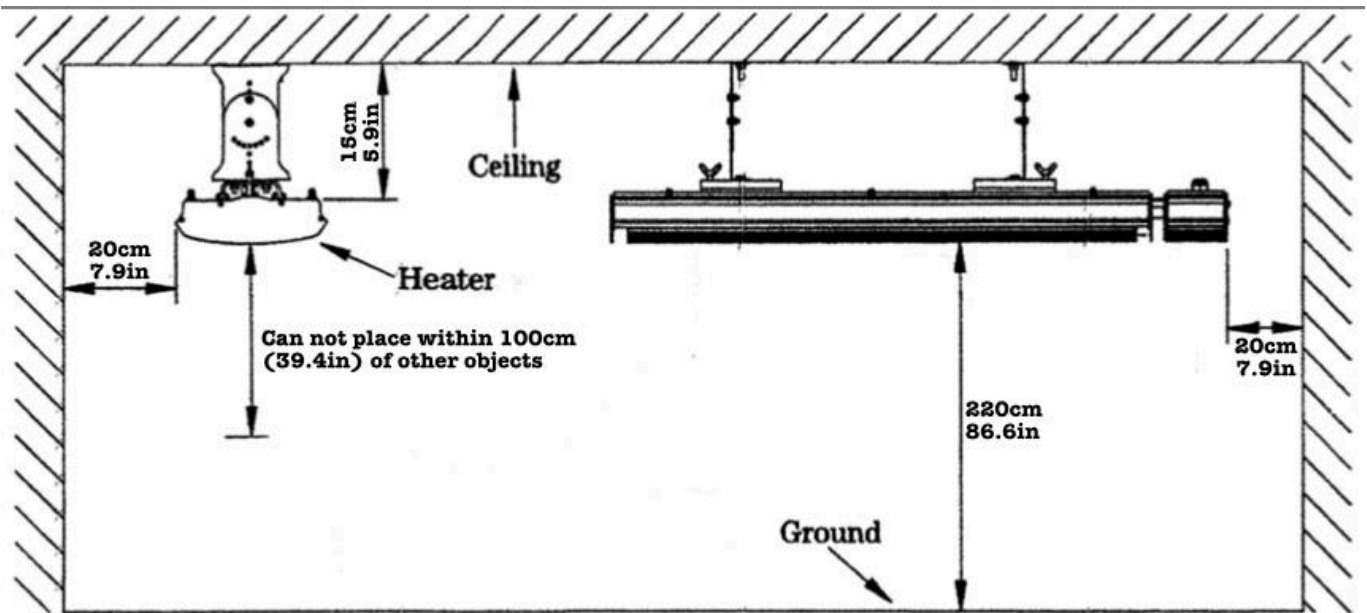

Picture 1

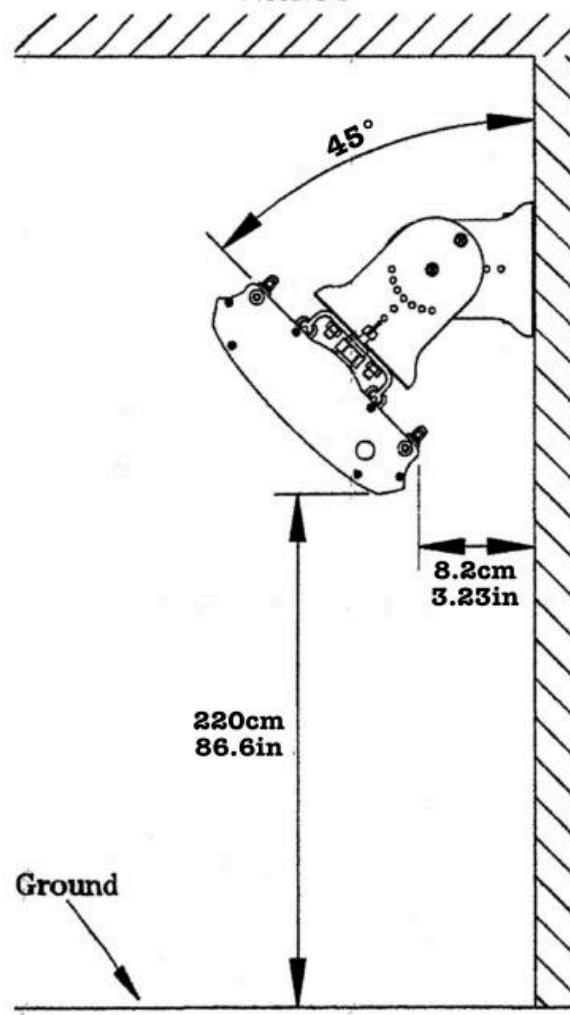

Picture 2

9. DISPLAY INTERFACE

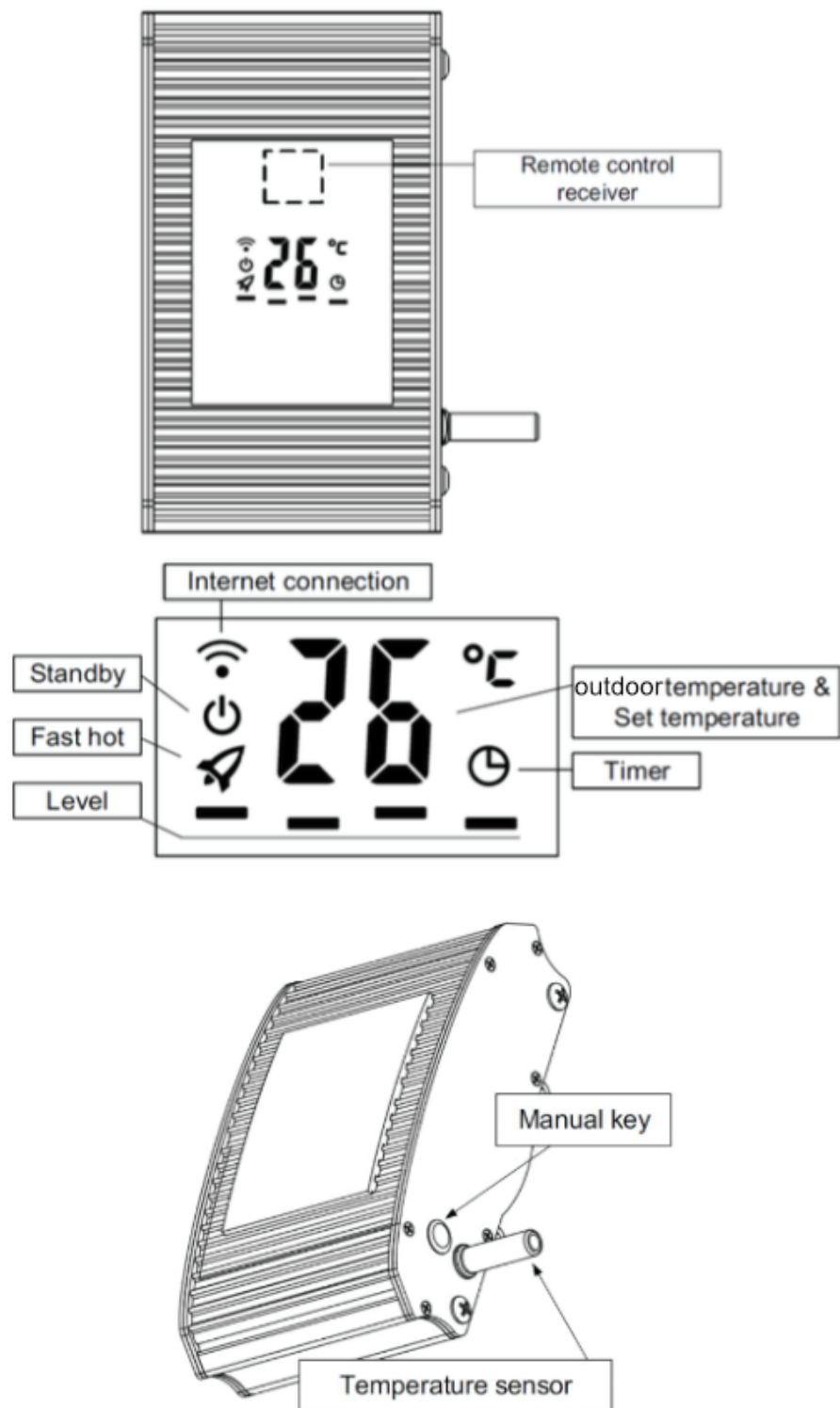

Manual Key

Press Manual Key button to turn on/off the heater, and set the heating level. Long press Manual Key to pair the Wi-Fi network(details as chapter 11).

Indoor temperature sensor

Using it to collect outdoor temperature.

10. REMOTE CONTROLLER

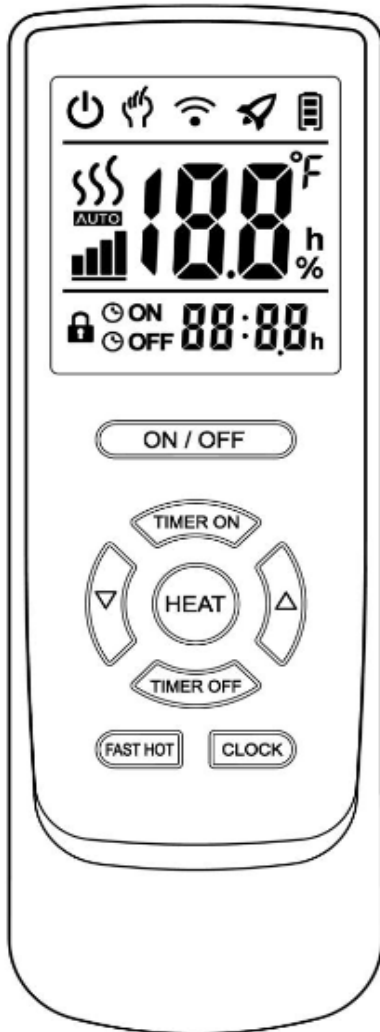

Remote appearance

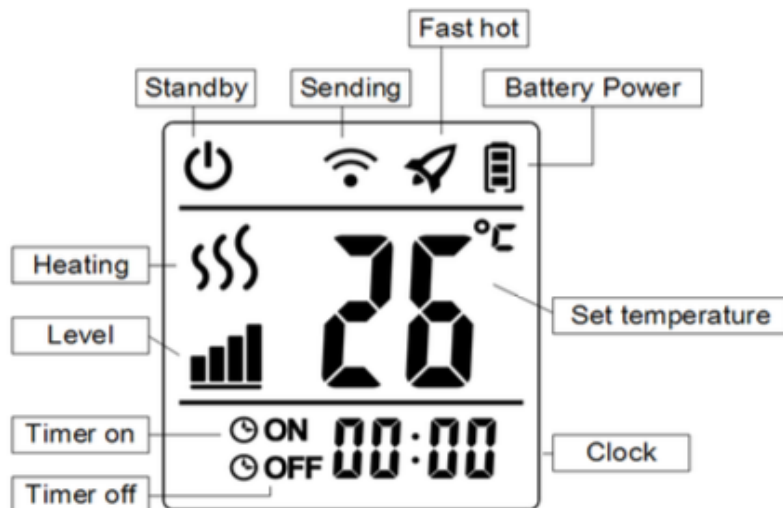

Remote LED display-

Remote LED display

1. ON/OFF button

Press ON/OFF button to turn on/off heater.

2. Clock button

Remote is powered on(as show in picture 2-1), present time is 00:00, time setting as follow:

- 1)Press clock button, the hour will flash(as show in picture 2-2), press up or down button to change hour setting.
- 2)Press clock button, the minute will flash(as show in pictures 2-3), press up or down button to change hour setting.
- 3)Press clock button, the second will flash(as show in picture 2-4), press up or down button to change hour setting.
- 4)Press clock button again, the second stop flashing and the setting is finished.



Pic2-1



Pic2-2



Pic2-3



Pic2-4

3. Heat button

Press level button to adjust the power when the heater is on(as show in picture 3-1).



Pic3-1

4. Fast hot button

Press fast hot button to turn on/off fast hot function.

Fast hot function is to let the heater run at full power for a certain time, to achieve the purpose of rapid heating.



Pic4-1

5. Timer on button

1)Press timer on button, it will show ON---(as show in picture 5-1).

2)Press up or down to change hour(as show in picture 5-2).

3)Press time on button again, hour stop shining and minute begin to shine, press up or down to change minute(as show in picture 5-3).

4)Press time on button again, timer on function finished. It will show the present time 16;30 and on. Time on setting finished(as show in picture 5-4).

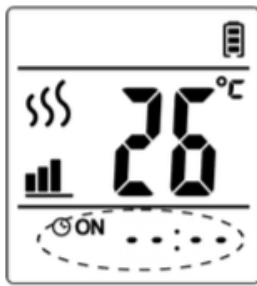

Pic5-1



Pic5-2



Pic5-3



Pic5-4

6.Timer off

1) Press timer off button, it will show off---(as show in picture 6-1).

2) Press up or down to change hour(as show in picture 6-2).

3) Press time off button again, hour stop shining and minute begin to shine, press up or down to change minute(as show in picture 6-3).

4) Press time off button again, timer off function finished. It will show the present time 16:30 and off. Timer off setting finished(as show in picture 6-4).

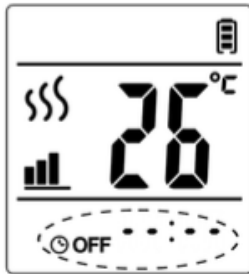

Pic6-1

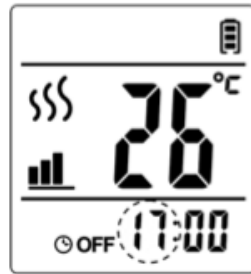

Pic6-2



Pic6-3



Pic6-4

11. CONNECT TO NETWORK

1. Download Tuya Smart App

Download Tuya Smart App from your smartphone (Google Play Store / App Store / AppGallery, etc.) or by scanning the following code.



Or download Tuya Smart App from <https://smartapp.tuya.com/tuyasmart>

2. Register / Log in

Register an account via mobile number or email address.

Log in with existing account if an account has already been set.

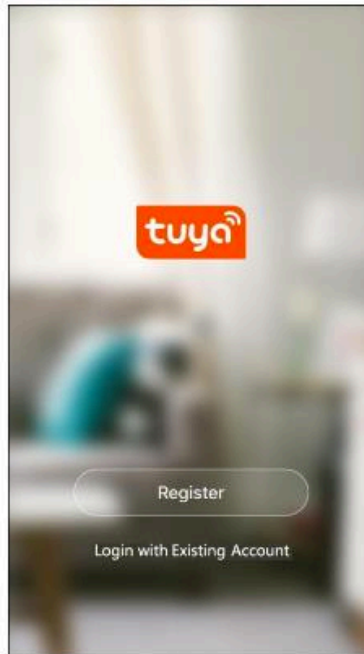

3. Home management

1. Click "Start your smart life" to "Add family"

2. Manually set a family name at "Add family". Set location at the map interface and change the location by coordinate point.

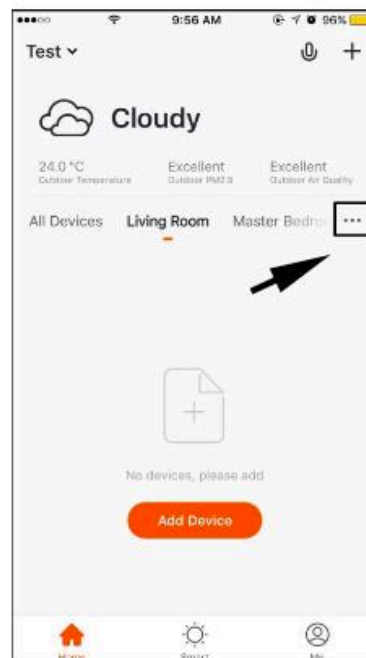
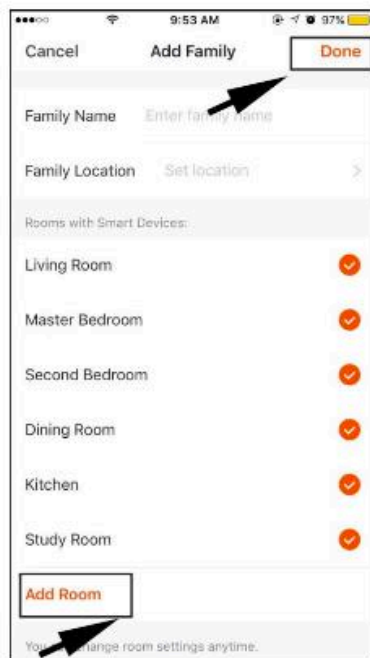

3. Click “Add Room” to add another room. By click “Done” to finish the room setting. And click “...” to proceed room management as needed.

Click “Home Management” to add family. One account can simultaneously control several families by selecting available devices at the family management page.

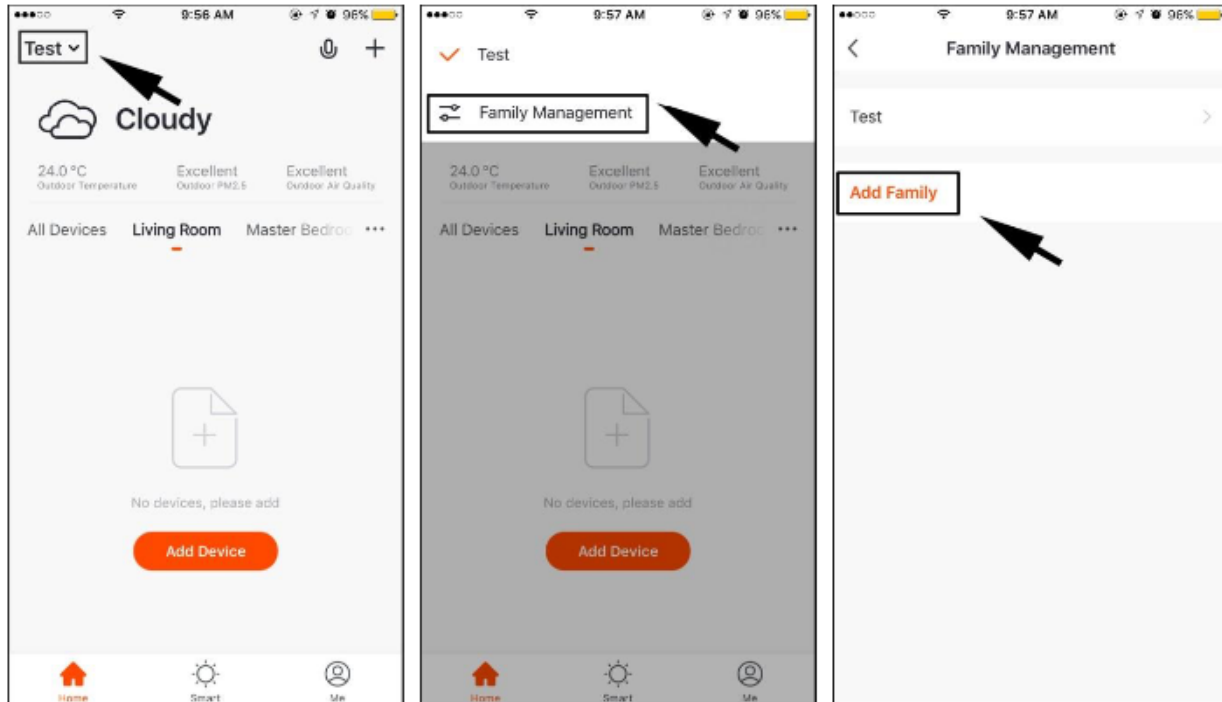

Click a family name to get into the “Family Settings” page and change the name, location and members as needed.

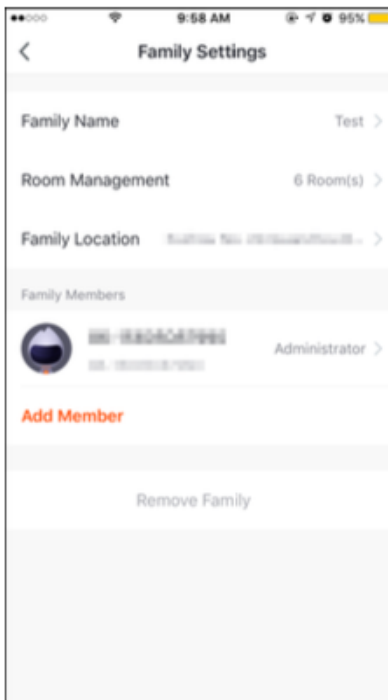

4. Add Devices

Keep pressing Manual Key over 8 seconds after power on, till heater has beep sounds and icon of Wi-Fi flashing (twice per second).

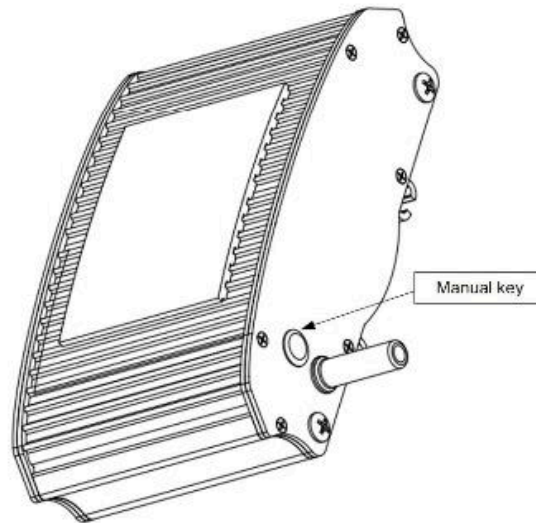

Click “add device” or “+” on the screen, find “Small Home Appliance”—“Heater”

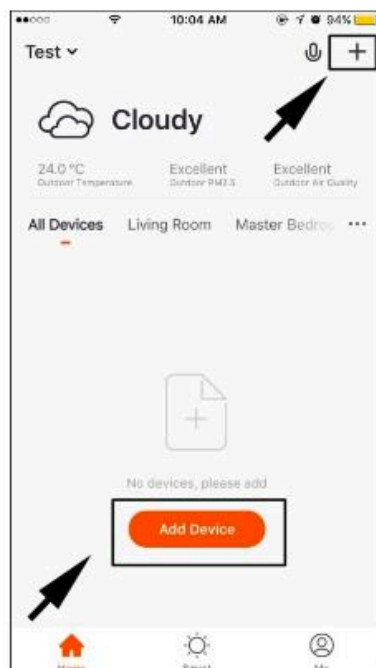

Press “Confirm indicator rapidly blink” and select a Wi-Fi signal nearby and enter Wi-Fi password to confirm the connection. Once the device added successfully, press “Done” to finish this procedure.

If failed, you need to re-add or search for help.

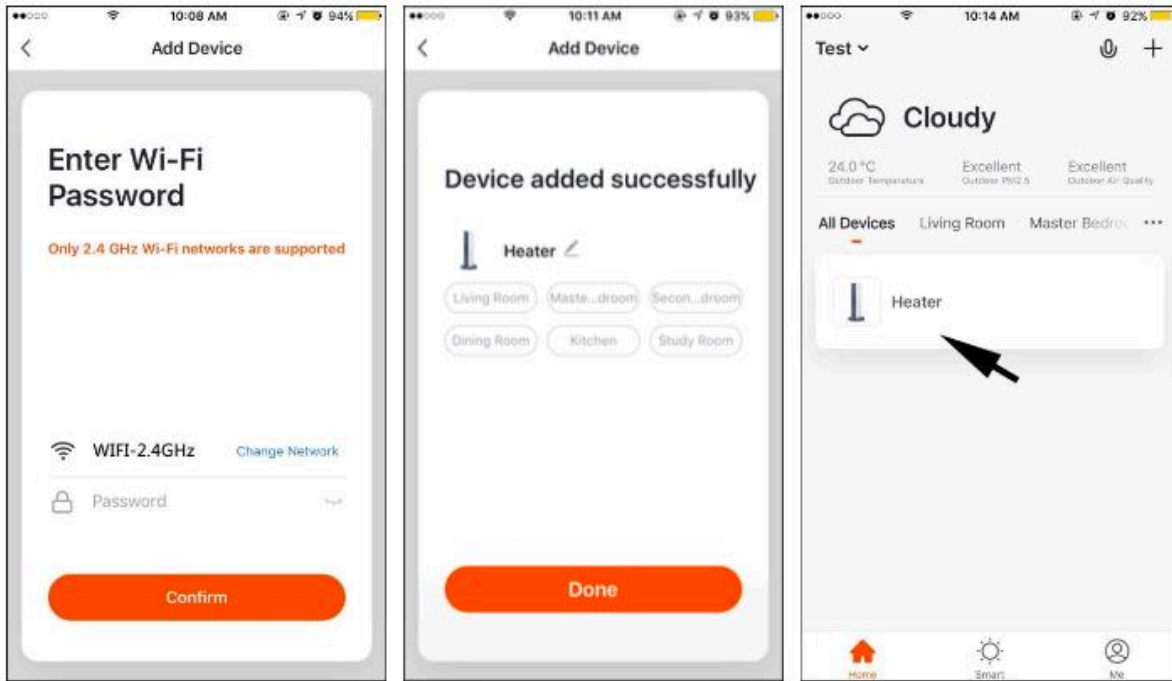

5. Using App to control heater

Once it's connected, you can use the App to control the heater.

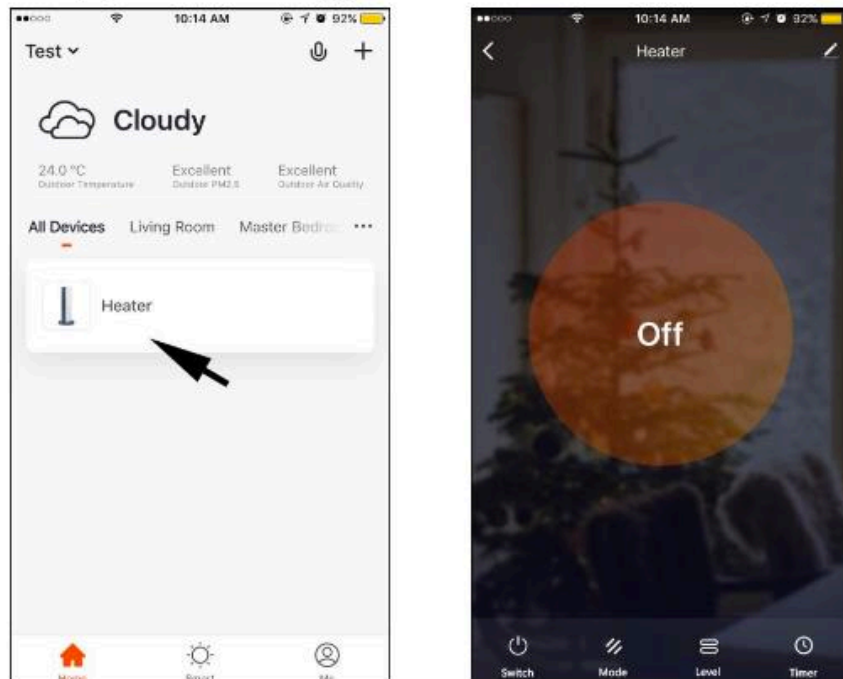

Switch: Turn on / off heater.

Mode: Set Auto / Manual mode.

Auto mode: set temperature.

Manual mode: Set temperature at 40°C (Unchangeable).

Level: Change heating levels.

Level_1 : Heating at 25% power.

Level_2 : Heating at 50% power.

Level_3 : Heating at 75% power.

Level_4 : Heating at 100% power.

Fast Hot: Turn on / off fast heat mode.

Timer: Set upmost 30 time logs.

WIFI signal strength: Shows the Wi-Fi signal strength. It comes the best at 100.

Note:

(1) All the above pictures are under iOS system. There's a slight difference between Android system.

(2) All the indications are just for your reference.

12. INSPECTION AFTER INSTALLATION

Items to be checked	Improper installation
Is the unit stable?	The equipment may fall off or shake
Is heat insulation adequate?	May damage objects close to unit
Is power voltage the same as voltage shown on product nameplate?	Equipment failure
Is the wired connection correct?	Equipment failure
Is grounded electrical connection safe?	Risk of electrical leakage
Does wiring conform to standards?	Equipment failure or circuit

13. ATTENTION

Due to thermal expansion and contraction, the heater will make noise when turning on and off. This is a normal phenomenon and will not affect unit performance.

14. STARTING HEATER FOR THE FIRST TIME

1. Do not turn on power before finishing all installation work.
2. Make sure all wired connections are correct and firm.
3. All objects must be removed from heater vicinity.
4. Power-up and observe working status.

13. SAFETY PRECAUTIONS

1. Do not use the same power outlet together with other appliances. Doing so may cause current overload.
2. Stop power supply immediately if heater fails or if wires are broken. Users should not repair heaters themselves. Contact authorized servicer if heater fails.
3. The radiant heater should not be placed directly above the power outlet.
4. The radiant heater shouldn't be installed lower than 2.2 meters (7.22 feet) from the ceiling.
5. The heater's surface cannot be covered.
6. Do not hang objects from the heater.
7. Distance from back of heater to ceiling/roof should not be closer than 150mm (6 inches). Distance from front of the heater and any object should not be within 1000mm (3.3 feet). Distance from a side of the heater and any object should not be within 200mm (7.87 inches).
8. For cleaning, turn the unit off and wait for a minimum of 1 hour. Then use a damp cloth to wipe exterior of the unit. Never use any cleaning products/chemicals on the heater itself. **DO NOT FLUSH OR SPRAY UNIT WITH WATER.**
9. Do not install or operate heater in areas with flammable or explosive objects or in areas where users are susceptible to electric shock (wet areas).
10. Do not insert any metal or foreign objects inside of heater.
11. Do not touch the surface of the heater when powered on. Surface temperature can reach 250°F ~ 380°F (121~193°C).
12. Do not splash water onto the heater to avoid accidents.
13. Wait for a minimum of 1 hour after powering heater OFF to touch the surface.
14. Make sure no cables, furniture, flammable materials or other items come into contact with the surface of the heater.
15. The local building and fire safety regulations must be observed concerning this product.

14. PACKING LIST

No.	Name	Qty
1	Heater	1 pc
2	Adjusting Bracket	4 pc
3	Sliding Bracket	2 pc
4	Fastener	1 set
5	Owner's Manual	1 copy
6	Certification	1 pc

15. PRODUCT SPECIFICATIONS

Model No.	Indoors	Outdoor Enclosed	Outdoor Exposed
<i>eRAD10R</i>	30ft ² ~ 2.8m ²	25ft ² ~ 2.3m ²	20ft ² ~ 1.9m ²
<i>eRAD15R</i>	50ft ² ~ 4.6m ²	40ft ² ~ 3.7m ²	30ft ² ~ 2.8m ²
<i>eRAD18R</i>	50ft ² ~ 4.6m ²	40ft ² ~ 3.7m ²	30ft ² ~ 2.8m ²
<i>eRAD24R</i>	80ft ² ~ 7.4m ²	65ft ² ~ 6m ²	50ft ² ~ 4.6m ²
<i>eRAD32R</i>	110ft ² ~ 10.2m ²	90ft ² ~ 8.4m ²	70ft ² ~ 6.5m ²

Model No.	Wattage(W)	Amperage(A)	Voltage(V)	Wire Length(in)
<i>eRAD10R</i>	1000	4.3	110-120	78.74
<i>eRAD15R</i>	1500	13.6	110-120	78.74
<i>eRAD18R</i>	1800	7.8	220-240	78.74
<i>eRAD24R</i>	2400	10.4	220-240	78.74
<i>eRAD32R</i>	3200	13.9	220-240	78.74

Model No.	Dimensions (in)	Weight (lbs)
<i>eRAD10R</i>	27 x 7 x 2.5	12
<i>eRAD15R</i>	43 x 7 x 2.5	17
<i>eRAD18R</i>	43 x 7 x 2.5	17
<i>eRAD24R</i>	62.5 x 7 x 2.5	24
<i>eRAD32R</i>	82.5 x 7 x 2.5	30

16. WARRANTY & RETURN POLICY

Limited Warranty

RADtec provides a 30-Day Return Window (see refund and return policy page) and the following limited warranty. This limited warranty extends only to the original purchaser.

Please note that any warranty services or questions must be accompanied by the order number from the transaction through which the warranted product was purchased and the ID number located on the unit. ***The order number and ID # serve as your warranty numbers and must be retained.*** RADtec will offer no warranty service without these numbers.

RADtec warrants this product and its parts against defects in materials or workmanship for ***3 years' parts and labor*** (residential use) and ***2 years' part and labor*** (commercial use) from the original ship date. During this period, RADtec will repair or replace defective parts with new or reconditioned parts at RADtec's option,

without charge to you.

Shipping fees incurred from returns for under-warranty service in the first 30-days will be paid by RADtec. All shipping fees both to and from RADtec following this 30-day period must be paid by the customer. All returns, both during and following the 30-day period, must be affected via the Procedures for Obtaining Warranty Service described below.

All original parts (parts installed by RADtec at the original build) replaced by RADtec or its authorized service center, become the property of RADtec. Any after-market additions or modifications will not be warranted. The heater owner is responsible for the payment, at current rates, for any service or repair outside the scope of this limited warranty.

RADtec makes no other warranty, either express or implied, including but not limited to implied warranties of merchantability, fitness for a particular purpose, or conformity to any representation or description, with respect to this heater other than as set forth below. RADtec makes no warranty or representation, either express or implied, with respect to any other manufacturer's product or documentation, its quality, performance, merchantability, fitness for a particular purpose, or conformity to any representation or description.

Except as provided below, RADtec is not liable for any loss, cost, expense, inconvenience or damage that may result from use or inability to use the heater. Under no circumstances shall RADtec be liable for any loss, cost, expense, inconvenience or damage exceeding the purchase price of the heater.

The warranty and remedies set forth below are exclusive and in lieu of all others, oral or written, expressed or implied. No reseller, agent or employee is authorized to make any modification, extension or addition to this warranty.

Warranty Conditions

The above Limited Warranty is subject to the following conditions:

1. This warranty extends only to products distributed and/or sold by RADtec. It is effective only if the products are purchased and operated in the USA. (Within the USA including US 48 States, Alaska, and Hawaii.)
2. This warranty covers only normal use of the heater. RADtec shall not be liable under this warranty if any damage or defect results from (i) misuse, abuse, neglect, improper shipping or installation; (ii) disasters such as fire, flood, lightning or improper electric current; or (iii) service or alteration by anyone other than an authorized RADtec representative; (iv) damages incurred through irresponsible use,

including those resulting from mounting the heater above a body of water, mounting the heater vertically and or other non-recommended practices.

3. You must retain your bill of sale or other proof of purchase to receive warranty service.
4. No warranty extension will be granted for any replacement part(s) furnished to the purchaser in fulfillment of this warranty.
5. RADtec makes no warranty either expressed or implied regarding third-party (non-RADtec) parts.
6. You must have filled out and filed your Warranty Card with RADtec to activate this warranty.

Return of Non-Defective Products

A non-defective product may be returned to RADtec within thirty (30) days of the invoice date for a refund of the original purchase price with the following amendments/fees:

1. RADtec will refund neither the original shipping cost nor the shipping and handling fees incurred from the products return. If the original purchase was made under a “Free Shipping” promotion, then a standard \$50 fee will be deducted from any return in counter to that offer.
2. No refund will be granted for the heater which has been used or tampered with in any way which jeopardized RADtec’s ability to remarket or resell the product. RADtec maintains full discretion in decisions regarding a product’s fitness for return.
3. No refund will be granted if the product has been installed OR more than 30 days has elapsed since the product was purchased.
4. Any non-defective returns are subject to a 15% restocking fee; which percentage is taken from the final purchase price less any shipping or handling charges.
5. Quantity purchases of five heaters or more are not eligible for return.

To return a defective product, please contact our Customer Service Department for a Return Merchandise Authorization (RMA) number and follow the Return of Products Instructions below. The RMA is valid for 10 days from the date of issuance. **Returns will not be accepted without an RMA.** Manufacturer restrictions do apply.

Procedures for Obtaining Warranty Service

RMA (Returning Merchandise Authorization) Policy:

If repairs are required, the customer must obtain an RMA number and provide proof of purchase. RMA and services are rendered by RADtec only. Any shipping costs after 30 days (starting from the original date of purchase) on any item returned for repair is the customers’ responsibility. All returned parts must have an RMA number written clearly on the shipping label of the package along with a copy of the original proof of purchase. No COD packages will be accepted. No package will be accepted without an RMA number written on the shipping label. RMA numbers are only valid for 30 days from the date of issue.

Should you have any problems with your heater, please follow these procedures to obtain the service:

1. Please contact RADtec’s Customer Service at 214-372-3872 or email at info@radtec.net.
2. If the heater must be repaired, an RMA number (Return Merchandise Authorization Number) will be issued for shipment to our repair department. Please follow the instructions given by RADtec’s technical support staff to ship your heater. RADtec will not accept any shipments without an RMA number.

3. Pack the heater in its original box or a well-protected box, as outlined in the Return Shipping Instructions. RADtec will not be responsible for shipping damage/loss of any product outside the original 30-day RADtec-paid service period. It is very important that you include the RMA number clearly on the shipping label of the package. Ship the heater with a copy of your bill of sale or other proof of purchase, your name, address, phone number, description of the problem(s), and the RMA number you have obtained to:

RADtec Service Center

***RMA# _____
10445 Vista Park Rd.
Dallas, TX 75238***

4. Upon receiving the heater, RADtec will repair or replace your heater (at RADtec's discretion) and will ship it back to you within 2 weeks (dependent on parts availability) via UPS.
5. RADtec will pay for shipping to the customer only within the first thirty days following the original product ship date. Following this 30-day period, all shipping fees both for under warranty and post-warranty repairs are the sole responsibility of the customer. The customer also assumes full liability for losses or damages resulting from shipping as well as all responsibility to pursue remuneration for such issues with their selected carrier.

After Three-Year Warranty – Post-Warranty Repair

For post-warranty repair, the procedure is the same as outlined above for RMA and shipping. However, you are responsible for shipping charges both ways, current labor (\$75 per hour if not under warranty), and the current price of part(s) used in the repair.

WARRANTY EXCLUSIONS:

RADtec accepts no liability for problems caused by after-market parts and hardware modifications or additions. RADtec is not responsible for giving any technical support concerning the installation or integration of any component the customer did not pay RADtec to install. This warranty is null and void if the defect or malfunction was due to damage resulting from operation not within manufacturer specifications. It will also be null and void if there are indications of misuse and/or abuse. RADtec has the option of voiding the warranty if anyone other than an RADtec technician attempts to service the product. RADtec will not warrant any problems arising from an act of God (lightning, flooding, tornado, etc.), electrical spikes or surges, or problems arising out of hardware, software, or additional devices added to complement any system/component bought at RADtec. Under no circumstances will RADtec be responsible for any refund or remuneration exceeding the original purchase price of the product less any shipping fees. RADtec will not be held responsible for typographical errors on sales receipts, repair tickets, or on our website. RADtec makes every effort to make sure all information on our website is correct.

Warranty Form

Cut along dotted line, fill out warranty card, and mail to RADtec.



WARRANTY FORM

Please fill out this warranty card and mail it with PROOF OF PURCHASE (RECEIPT) within 30 days of purchase to: RADtec Group, LLC., 11530 Chairman Dr. Unit 100, Dallas, TX 75243, USA.
Or email to info@radtec.net

Item:

ID:

Customer Name:

E-mail:

Address:

Phone No:

Where Purchased:

Date of Purchase:

My signature below acknowledges that I have read, fully understand, and accept the limited warranty agreement.

The limited warranty agreement can be found on www.radtec.net.

Signature:

Date:

Important: Our company does not provide email or personal information to any third party entity for any reason. All information provided is kept secure and private and is used solely for the purpose of warranty administration and informational purposes.

RADtec Group, LLC. |Phone: 214-295-6889
www.RADtec.net



**. BLANK PAGE
. FOR NOTES**

RADtec
The Source for Outdoor Heating