

# Avco Lycoming **TEXTRON**

## Williamsport Division

Avco Lycoming/Subsidiary of Textron Inc.  
652 Oliver Street  
Williamsport, PA 17701 U.S.A.  
717/323-6181

# SERVICE INSTRUCTION

DATE: August 15, 1986

SUBJECT: Engine Timing Marks

MODELS AFFECTED: All Avco Lycoming Direct Drive Engines

TIME OF COMPLIANCE: Each 100 hour inspection.

Service Instruction No. 1437  
Engineering Aspects are  
FAA Approved

During each 100 hour inspection, Avco Lycoming Textron recommends the use of one of two methods for checking alignment of engine timing marks prior to timing magneto to engine.

### NOTE

Refer to the applicable Operator's Manual; Section 2 for correct advance timing mark and Section 5 for correct magneto to engine timing procedures.

### WARNING

TO ELIMINATE THE POSSIBILITY OF THE ENGINE STARTING WHILE TURNING THE PROPELLER BY HAND, INSURE THAT THE MAGNETOS ARE GROUNDED AND THE FUEL METERING DEVICE IS LOCKED INTO THE IDLE CUT-OFF POSITION.

The first method requires removing a spark plug from No. 1 cylinder and placing your thumb over the spark plug hole. Rotate the crankshaft in the direction of normal rotation until No. 1 cylinder is in the compression stroke, indicated by a positive pressure inside the cylinder tending to push the thumb off the spark plug hole. Continue rotating the crankshaft until the appropriate advance timing

mark on the front face of the starter ring gear support lines up with the small dot (hole) located at the two o'clock position on the front face of the starter Bendix gear housing. See Figure 1. Leave the crankshaft in this position until the magneto timing has been checked and any corrections to the timing have been made.

The second method requires bringing the No. 1 cylinder into the compression stroke in the same manner as in the first method. Then clamp the ignition timing pointer (Avco Lycoming Tool P/N 64697) on the appropriate advance timing mark on the back face of the starter ring gear support as shown in Figure 2. Continue rotating the crankshaft until the ignition timing pointer and the split line of the two crankcase halves align. Leave the crankshaft in this position until the magneto timing has been checked and any corrections to the timing have been made.

In addition, a further inspection should be made to determine that the alignment is still correct as manufactured by making sure the starter ring gear is still in it's original installed position and has not moved on the ring gear support. See Figure 1. During assembly, the identification mark "O" on the front face of the starter support assembly is lined up with the identification mark "O" on the crankshaft face. See Figure 3.

**NOTE**

**MARKS ON THE RING GEAR AND SUPPORT HOUSING SHOULD BE IN ALIGNMENT. IF THESE MARKS ARE NOT IN ALIGNMENT. IT CAN BE DETERMINED THAT THE RING GEAR HAS MOVED ON THE SUPPORT HOUSING AND THE ENTIRE ASSEMBLY MUST BE REPLACED BEFORE RE-TIMING THE ENGINE.**

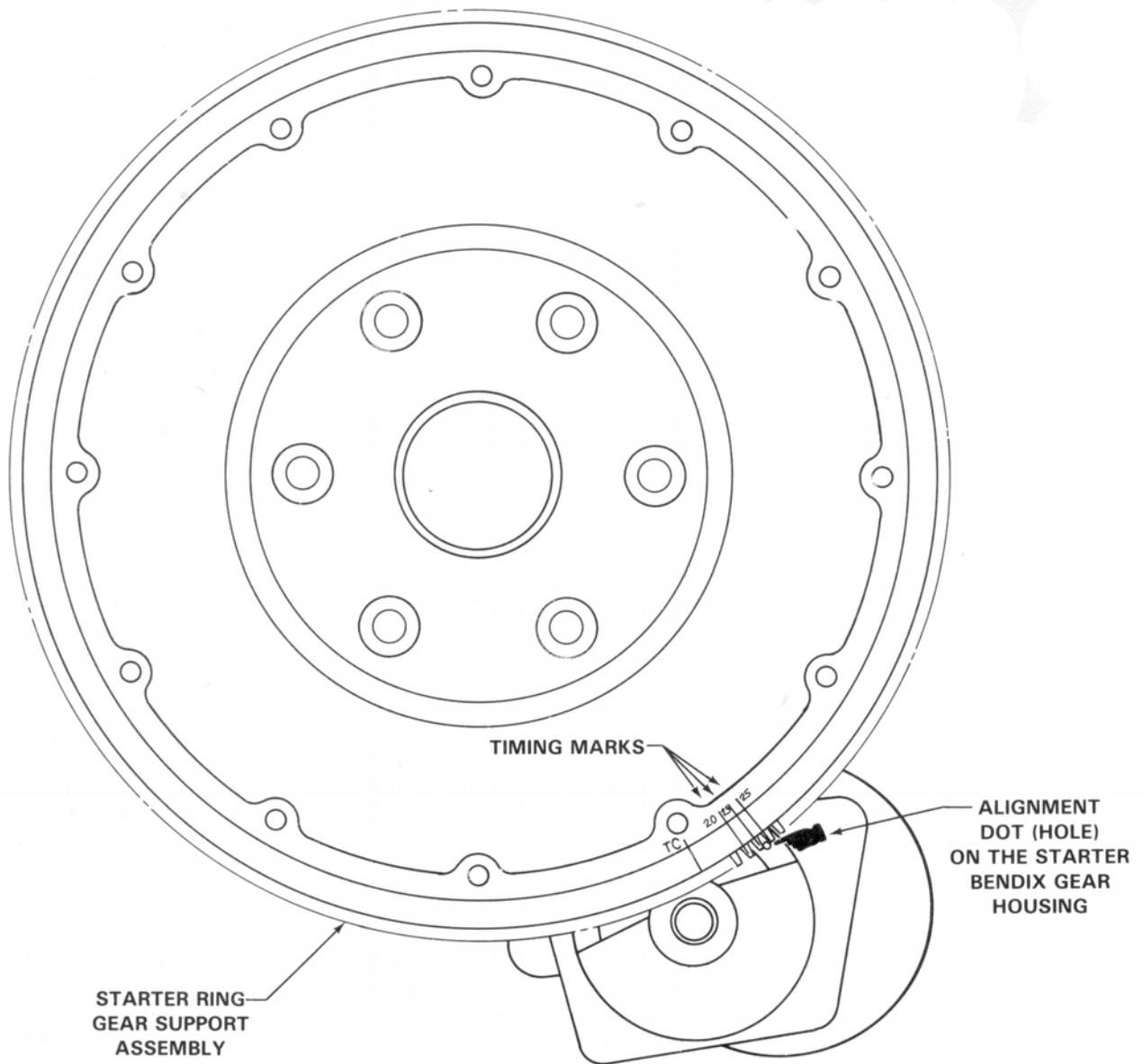

Figure 1. Correct Alignment of Advance Timing Marks with Starter Housing

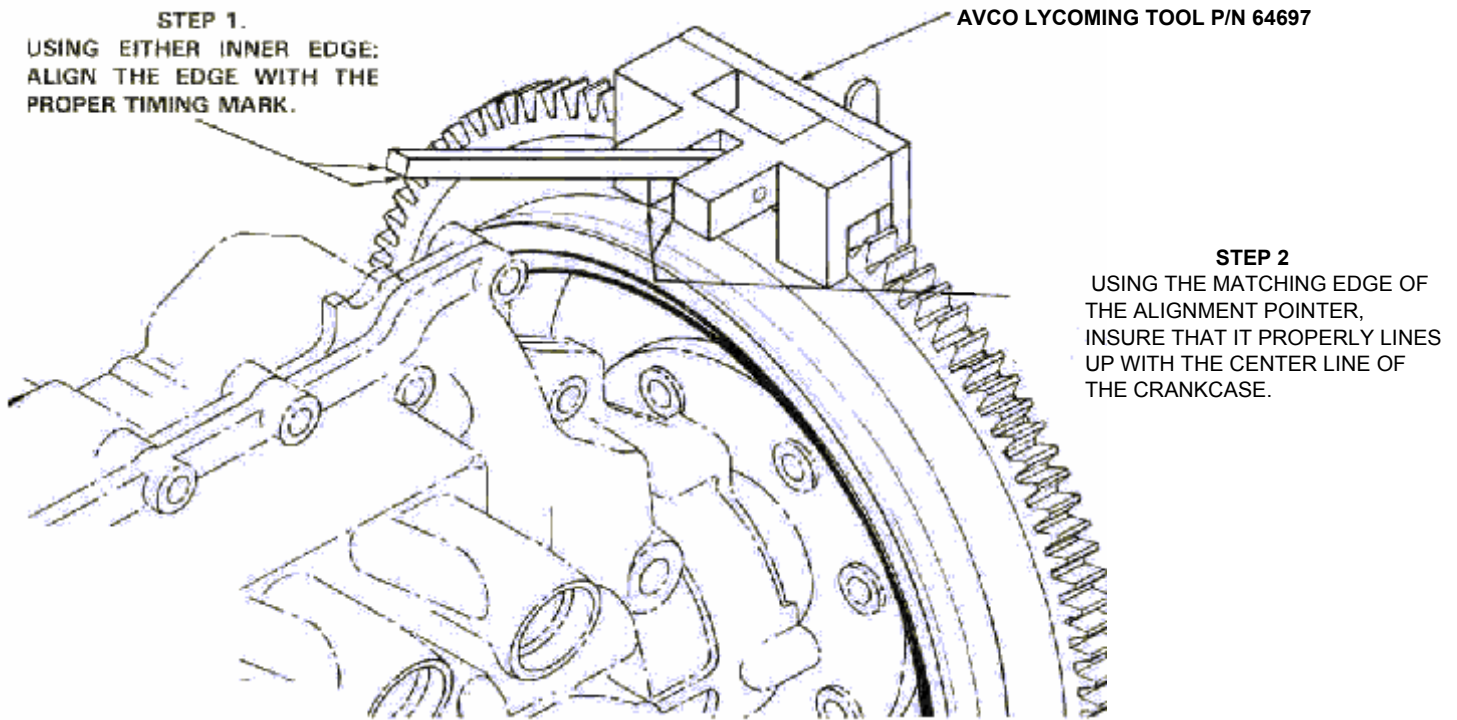

Figure 2. Use of Avco Lycoming Tool P/N 64697

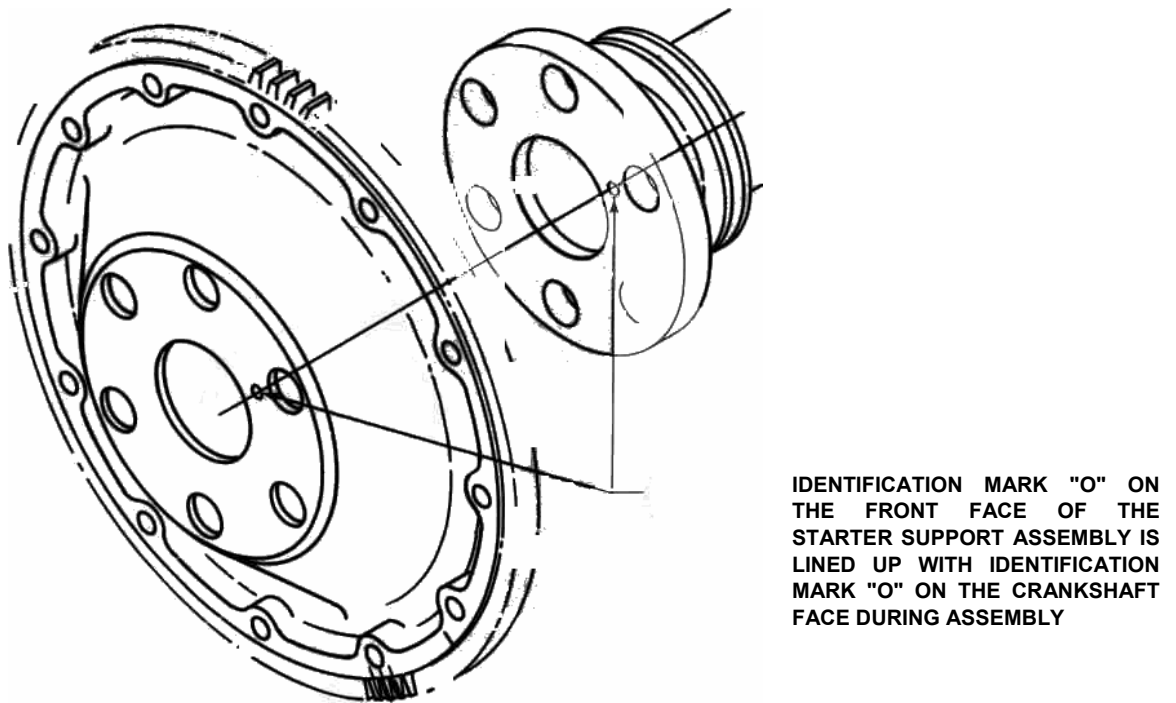

Figure 3. Alignment of Identification Marks at Assembly