

Air-Row for Open Ceilings

F-18 and AF-22



Control your environment, solve building problems and cut energy costs with today's best performing de-stratification fans.

Air-Row Fans use what you already have — the trapped air at the ceiling — to equalize the temperature down below. In the process, we allow your HVAC system to cycle off and bring you significant energy savings.

Air-Row's open ceiling products push air down in a column no wider than 2' to 3' from as high as 40' up without a spread that interferes with cases below.

Our square fans are common in warehouse applications, while the round fans were developed in answer to customer demand for a more sophisticated retail aesthetic.



Air-Row De-Strat Fans Bottom-Line Advantages

- Cut HVAC-related energy costs by more than 25%
- Extend the performance life of HVAC equipment
- Maintain dry floors and prevent accidents for improved customer safety
- Redistribute air and eliminate stale air to improve air quality standards
- Improve overall comfort for employees and customers
- Target air to strategically resolve building challenges
 - Hot and cold spots
 - Wet floors
 - Fogging/sweating on doors and windows
 - Mold/mildew build-up
 - Starving long-runs



421 Industrial Drive
Carmel, IN 46032
www.airrowfans.com

Office: 317-691-7255
Sales: 317-691-7255
Tech Support: 317-574-1009





Air-Row F-18

3-Speed

Size - 12"x12"x22"
 Weight - 8.1 lbs.
 Volts - 120 V / 60 CY

Air-Row AF-22

2-Speed

Size - 12"x12"x22"
 Weight - 8.1 lbs.
 Volts - 120 V / 60 CY



Performance

Speed	RPM	CFM	Watts
High	1550	1061	31
Med	1300	891	20
Low	900	616	8

Performance

Speed	RPM	CFM	Watts
High	1550	1061	23
Low	1000	616	10

Features and Options –



Electronically Controlled Motor – Air-Row Fan products come standard with a multi-speed programmable EC motor, thermally protected; on/off switch may be factory preset.

Durable Metal – Air-Row fans are created of durable metal for a long-life and exceptional performance years after installation.



Speed Control and BAS Interface – Air-Row fans may be grouped in multiple and tied to a controlled integrated circuit available to interface with BAS.

Easy Field Serviceability – Air-Row fan products are field serviceable, allowing easy access for maintenance and repair.



Paint and Color Matching – Air-Row fans may be paint matched and powder coated to conform to store environments.

From Our Customers –

“We had three rooftop units working full-time. With the fans, we now have one. Our night recovery went from four hours to 30 minutes.”

New from Air-Row – Our Open Ceiling Lay-In

Perfect when air from the plenum is not a concern, Air-Row's new open ceiling lay-in product is now in testing.

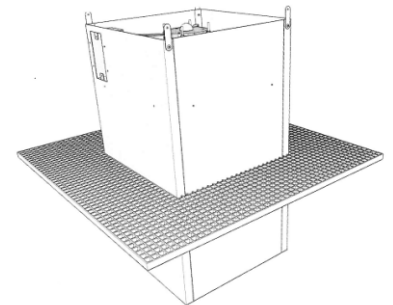

421 Industrial Drive
 Carmel, IN 46032
www.airrowfans.com

Office: 317-691-7255
 Sales: 317-691-7255
 Tech Support: 317-574-1009

