

Ultra-Efficient CX34 Chiller Heat Pump

2 Tons Cooling / 3 Tons heating
IPLV Cooling 26,615 BTU COP 6.75 EER 23.02
NPLV Cooling 30,049 BTU COP 9.0 EER 30.72
Heating 33,813 BTU COP 3.92



Ultra High Efficiency Heat Pump Chiller

The CX34 obtains its ultra high efficiency using existing technologies in a new way. For example, we use a DC Inverter compressor and a DC Inverter water pump (both are variable speed) controlled together with a DC inverter fan motor to achieve the best possible balance of water flow rate, compressor speed, and energy use.

A special control algorithm looks at the temperature delta between the entering and exiting water temperatures of the chiller, and also compares the exiting water temperature to the system settings. The controller constantly adjusts the pump and compressor speeds independently of each other to maintain the needed capacity at the lowest possible power draw, usually avoiding the need for a buffer tank. There is not a more efficient air source heat pump chiller made anywhere by anyone.

Dynamic Humidity Control (DHC)

The Chiltrix Psychrologix™ controller offers DHC (Dynamic Humidity Control) to maximize comfort and performance and allow the unit to operate well above its published ratings at times when humidity allows. The controller provides dynamic loop/coil temperature adjustment among other features.

The CX34 system capacity is fully dynamic and can operate between 25% and 100% of its rated capacity, as needed, and matches its actual capacity to the instantaneous heating or cooling load in real time. This means the system is always the right size for changing conditions and is never oversized and avoids the on/off cycling of traditional systems.

Multiple IDUs - Up to 8 Indoor Units Per CX34



Save More w/ DC Inverter Fan Motors

All of the thin-line (5.1" thin) wall, floor and ceiling fan coil units use high efficiency and nearly silent DC Inverter fan motors, designed for 115v 50/60Hz power. 220v 50/60Hz standard FCUs are available for export customers.

Geothermal Performance

There is no Energy Star program for air to water heat pumps. However, the Chiltrix air-cooled chiller exceeds the Energy Star EER requirements for geothermal water-to-water systems.

Server Room Cooling

Chiltrix offers an optional Free Cooling add-on which allows up to EER 141+ & COP 41+ cooling performance during winter at low ambient temperatures. Chiltrix chillers are also available in a N+1 redundant configuration.

Solar Ready

Perfect for solar PV operation with super low power draw and a 2 amp soft start that's easy on inverters and batteries. Also integrates directly with solar PV, solar thermal hydronic heating & solar water heating systems.

Radiant, Boiler & Hydronic Integration

Can serve as low-cost primary heat when used with an existing boiler heating system. Perfect for radiant floor heating. Dramatically reduces heating costs for users of electric, propane or oil fired boiler systems.

Modular – Stackable

The CX34 can be configured with up to 3 outdoor units to create systems up to 6 Tons Cooling/8.5 Tons Heating

Dynamic Heating Performance

The CX34 provides heating down to outdoor temperatures as low as -4 °F (-20 °C). And the optional V18 variable backup heater can be directly integrated for precise control and the highest efficiency ever achieved by an electric hydronic backup heater.



UL 60335-2-40 / CSA 22.2 / SGS

All Specifications Subject To Change



The World's Most Efficient Chiller Heat Pump



Ultra-Efficient CX34 Chiller Heat Pump

2 Tons Cooling / 3 Tons heating
 IPLV Cooling 26,150 BTU COP 6.75 EER 23.02
 NPLV Cooling 30,049 BTU COP 9.0 EER 30.7
 Heating 33,813 BTU COP 3.92

The CX34 is Stackable up to 3 Systems
 Use up to 8 Indoor Units per Outdoor Unit.

UL 6035-2-40 / CSA C22.2 / SGS

Best of Breed Components

At Chiltrix we used every trick in the book and then some to deliver the highest electrical efficiency possible. And we didn't stop there. The components we use to build our chillers are sourced from the world's top manufacturers and include heat exchangers from Sweden, German pumps, American valves, electronics from Japan, controls from USA, and a compressor from Mitsubishi.

No corner has been cut when it comes to making sure that the parts and materials used to manufacture the CX34 are the best available. Our chiller is designed for performance - to deliver the lowest kW usage per BTU of any chiller heat pump available, and to perform this task for a 20-year service life.

Anti-Corrosion Technology to protect against salt air or air pollution is incorporated into all Chiltrix outdoor units. Includes special coil, sealed compressor and fan motor.

There is no other chiller like the CX34 available on the market at any price. Contact us to learn more about designing a chiller system for your home, commercial location, or server room. We can also help you integrate our system with an existing system, retrofit replacement, integration with solar or to an existing boiler or hydronic heating system.

Flexible Indoor Options

You can use up to 8 ductless fan coil units of any type including high-wall (mini-split type), low wall, ceiling, floor standing, etc. with the Chiltrix air to water heat pump chiller. You can also use (AHU) ducted fan coil air handlers for a central (forced air) heating & air conditioning system, use radiant floor or radiant panels, or use any combination of these.

Model CX34 Per AHRI 550/590	Ambient / LWT (°F)	Capacity / Input BTU/kW
Heating	at A43/W95	33,813/2.53
	at A17/W95	22,237/2.32
Cooling	Efficiency A95/W44	IPLV EER 23.02
	Efficiency A95/W54	NPLV EER 30.7
Cooling Capacity/Max Power Input(kW)	at A95/W44	26,150 / 2.36
	at A95/W54	30,049 / 2.36
Input Power	Variable (kW)	.364 - 2.36
Max.Current/ Min. Circuit (A)		15/20
Electric supply		208-240V / 50-60HZ
Max.Water Temperature (°C)		55 (131F)
Operating Temperature Range (°C)		-20 ~ 50 (-4F ~ 122F)
Refrigerant Circuit	Refrigerant	R410a
	DC Inverter Compressor(s)	Mitsubishi Scroll - DC Inverter
	Heat Exchanger	Cu/Al Hydrophilic w/ Anti-Corrosion
	Electronic Expansion Valve	Saginomiya Japan
	Condenser Fan Motor	Panasonic DC Fan
	Max Air flow (CFM)	1700
Water Circuit	Heat exchanger	Multistack BPHE
	Inlet / Outlet	1" NPT
	Water Flow - Max	7.6 GPM
	Pump	Wilo DC Variable Speed
	Max/Std. Pressure	115/25 PSI
Unit Dimensions WxHxD (Inch)		43.9 x 38.15 x 16.74
Package Dimensions WxHxD (Inch)		46 x 49.25 x 18.5
Net Weight (Lbs.)		232
Gross weight (Lbs.)		254
Noise level dB(a)		49

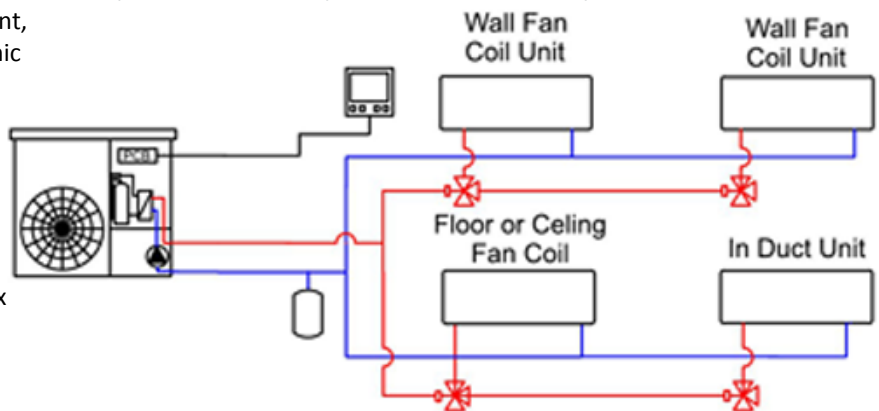

Distributed By: **hotspot energy**

HotSpot Energy Inc.
 4021 Holland Blvd.
 Chesapeake VA 23323
 www.hotspotenergy.com

info@hotspotenergy.com
 1-757-410-8640



All Specifications Subject To Change

