

Technical Specifications



13, 14 & 16 SEER SPLIT SYSTEM AIR CONDITIONERS (REV-B)

Conforms to UL Standard 1995. Certified to CAN/CSA Standard C22.2 No.236.



- 13, 14 and 16 SEER efficiencies
- Capacities ranging from 1.5 tons to 5.0 tons
- Environmentally friendly R-410A refrigerant
- High Efficiency Compressors
- Micro-Channel Condenser
- Swept Fan Blades
- Permanently lubricated PSC motor
- Motor assembly is removable from top of unit
- Service valves and refrigerant connections are located outside the cabinet for easy accessibility and servicing
- Electrical connections are accessible through a removable service panel

FEATURES AND BENEFITS

Advanced micro-channel coil technology

Napoleon Air Conditioners are made with superior micro-channel condenser coils that wrap around the inside of air conditioner and house the refrigerant. The coils are compact, allowing for a smaller air conditioner size while using substantially less refrigerant. The condenser coils are all aluminum, easy to maintain and are less susceptible to corrosion as are the bimetal tube and fin coils.

Environmentally Responsible

Napoleon air conditioners are made with the environmentally conscious, chlorine-free refrigerant R-410A. By using a refrigerant that is chlorine-free, Napoleon air conditioners do not contribute to ozone depletion.

NOMENCLATURE

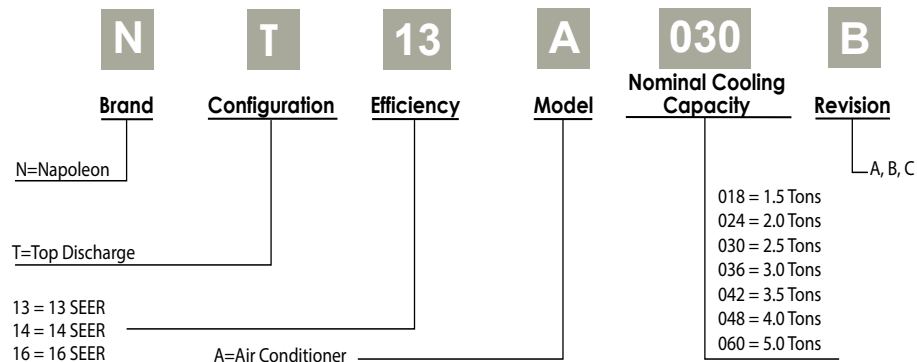

COMPONENTS

1. SIDE PANELS

- Vertical extruded slots on the side panels protect the interior of Napoleon air conditioner while allowing the right amount of air flow
- Powder coated cabinet panels withstanding 1000 hours of salt spray testing

2. MICRO-CHANNEL COILS

- Compact all-aluminum coils allow for smaller air conditioner size

3. VENTURI

- Integral to the housing, a deep venturi is used in conjunction with the swept fan blade to provide more efficient air flow

4. SWEPT FAN BLADES

- Contoured blades provide quieter operation
- Produces efficient air flow
- Fans are made up of 4 or 2 fan blades to accommodate the unit cooling capacity

5. SCROLL COMPRESSOR

- Industry leading compressor brand
- Low vibration and quiet operation
- Contains built-in safety features



13B SEER SPECIFICATIONS

DIMENSIONS

NOM SIZE	MODEL	W (inch)	D (inch)	H (inch)	Weight (lb)
1.5 Tons	NT13A018B	24	24	27	150
2.0 Tons	NT13A024B	24	24	27	150
2.5 Tons	NT13A030B	24	24	27	150
3.0 Tons	NT13A036B	29 ½	29 ½	27	180
3.5 Tons	NT13A042B	29 ½	29 ½	27	180
4.0 Tons	NT13A048B	29 ½	29 ½	38 ¾	230
5.0 Tons	NT13A060B	29 ½	29 ½	38 ¾	230

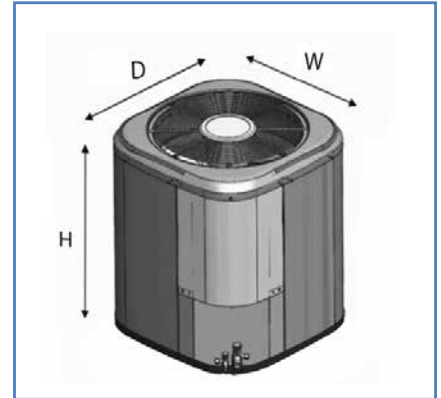

13B SEER

ELECTRICAL

DESCRIPTION	NT13A018B	NT13A024B	NT13A030B	NT13A036B	NT13A042B	NT13A048B	NT13A060B
Compressor Type	Scroll	Scroll	Scroll	Scroll	Scroll	Scroll	Scroll
Ref Charge (oz) 410A	49	45	59	60	57	87	86
Volt-Hz-Phase	208/230-60-1	208/230-60-1	208/230-60-1	208/230-60-1	208/230-60-1	208/230-60-1	208/230-60-1
Compressor LRA (A)	56.3	62.9	67.8	72.2	109	124	152.5
Compressor RLA (A)	9	10.9	12.8	14.1	16.7	18.5	23.7
Fan Blade Dia. / qty blades	18" / 4	18" / 4	18" / 4	24" / 2	24" / 2	24" / 2	24" / 2
Condenser Fan FLA / HP / RPM rated	0.7 / ½ / 1075	0.7 / ½ / 1075	0.7 / ½ / 1075	0.8 / ½ / 850	0.8 / ½ / 850	0.8 / ½ / 850	0.8 / ½ / 850
MCA	12	14.3	16.7	18.4	21.7	23.9	30.4
Max. Fuse/Breaker (A)	20	25	25	30	35	40	50

LINE SET

LINE SIZES	NT13A018B	NT13A024B	NT13A030B	NT13A036B	NT13A042B	NT13A048B	NT13A060B
Liquid Line	¾"	¾"	¾"	¾"	¾"	¾"	¾"
Suction Line	¾"	¾"	¾"	¾"	¾"	¾"	¾"

PERFORMANCE

NOM SIZE	MODEL	Capacity Btu/h	SEER	EER	SCFM Indoor Air Coil	Ref.	Weight (lb)
1.5 Tons	NT13A018B	18000	13.0	11.7	600	R410A	150
2.0 Tons	NT13A024B	22000	13.0	11.6	800	R410A	150
2.5 Tons	NT13A030B	27200	13.0	11.3	1000	R410A	150
3.0 Tons	NT13A036B	33000	13.0	12.15	1165	R410A	180
3.5 Tons	NT13A042B	37000	13.0	11.6	1260	R410A	180
4.0 Tons	NT13A048B	43500	13.0	12	1550	R410A	230
5.0 Tons	NT13A060B	52000	13.0	11.4	1550	R410A	230

NOTE:

ALL NAPOLEON AIR CONDITIONERS SHALL BE INSTALLED WITH PROPERLY MATCHED SYSTEM COMPONENTS LISTED ON AHRI DIRECTORY.

14B SEER SPECIFICATIONS

DIMENSIONS

Nom. Size	MODEL	W (inch)	D (inch)	H (inch)	Weight (lb)
1.5 Tons	NT14A018B	24	24	27	150
2.0 Tons	NT14A024B	24	24	27	150
2.5 Tons	NT14A030B	29 ½	29 ½	27	180
3.0 Tons	NT14A036B	29 ½	29 ½	27	180
3.5 Tons	NT14A042B	29 ½	29 ½	38 ¾	230
4.0 Tons	NT14A048B	29 ½	29 ½	38 ¾	230
5.0 Tons	NT14A060B	29 ½	29 ½	47 ¾	250

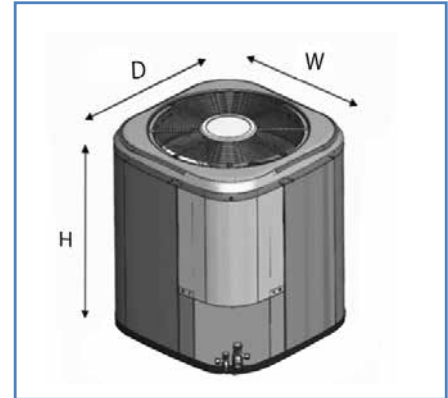

14B SEER

ELECTRICAL

DESCRIPTION	NT14A018B	NT14A024B	NT14A030B	NT14A036B	NT14A042B	NT14A048B	NT14A060B
Compressor Type	Scroll	Scroll	Scroll	Scroll	Scroll	Scroll	Scroll
Ref Charge (oz) R410A	56	58	57	63	80	94	95
Volt –Hz –Phase	208/230 - 60 - 1	208/230 - 60 - 1	208/230 - 60 - 1	208/230 - 60 - 1	208/230 - 60 - 1	208/230 - 60 - 1	208/230 - 60 - 1
Compressor LRA (A)	56.3	62.9	67.8	72.2	109	123.9	152.5
Compressor RLA (A)	9.0	10.9	12.8	14.1	16.7	17	23.7
Fan Blade Dia. / qty blades	18" / 4	18" / 4	24" / 2	24" / 2	24" / 2	24" / 2	24" / 2
Condenser Fan FLA / HP / RPM rated	0.7 / ⅛ / 1075	0.7 / ⅛ / 1075	0.8 / ⅛ / 850	0.8 / ⅛ / 850	0.8 / ⅛ / 850	0.8 / ⅛ / 850	1.1 / ⅛ / 850
MCA	12.0	14.3	16.8	18.4	21.7	22.1	30.7
Max. Fuse/Breaker (A)	20	25	25	30	35	35	50

LINE SET

LINE SIZES	NT14A018B	NT14A024B	NT14A030B	NT14A036B	NT14A042B	NT14A048B	NT14A060B
Liquid Line	⅜"	⅜"	⅜"	⅜"	⅜"	⅜"	⅜"
Suction Line	¾"	¾"	¾"	¾"	⅞"	⅞"	⅞"

PERFORMANCE

Nom. Size	MODEL	Capacity Btu/h	SEER	EER	SCFM Indoor Air Coil	Ref.	Weight (lb)
1.5 Tons	NT14A018B	18800	14.0	12.0	600	R410A	150
2.0 Tons	NT14A024B	23400	14.0	12.0	775	R410A	150
2.5 Tons	NT14A030B	28600	14.5	12.2	1000	R410A	180
3.0 Tons	NT14A036B	33800	14.0	12.0	1100	R410A	180
3.5 Tons	NT14A042B	38000	14.0	11.5	1275	R410A	230
4.0 Tons	NT14A048B	44000	14.0	11.5	1575	R410A	230
5.0 Tons	NT14A060B	53500	14.0	11.5	1475	R410A	250

*All specifications and designs can change without notice to allow for on-going improvements. Images may not be exactly as shown. Consult with your owner's manual for current information. Check all local and national building codes. Napoleon is a registered trade mark of Wolf Steel Ltd.

NOTE:

ALL NAPOLEON AIR CONDITIONERS SHALL BE INSTALLED WITH PROPERLY MATCHED SYSTEM COMPONENTS LISTED ON AHRI DIRECTORY.

DIMENSIONS

Nom. Size	MODEL	W (inch)	D (inch)	H (inch)	Weight (lb)
1.5 Tons	NT16A018B	29 ½	29 ½	27.0	180
2.0 Tons	NT16A024B	29 ½	29 ½	27.0	180
2.5 Tons	NT16A030B	29 ½	29 ½	27.0	180
3.0 Tons	NT16A036B	29 ½	29 ½	38 ¾	230
3.5 Tons	NT16A042B	29 ½	29 ½	38 ¾	230
4.0 Tons	NT16A048B	29 ½	29 ½	47 ¾	250
5.0 Tons	NT16A060B	29 ½	29 ½	47 ¾	250

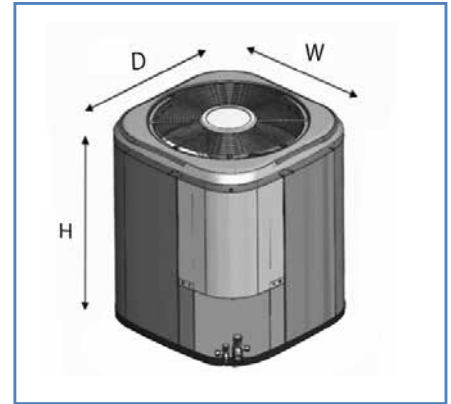

16B SEER

ELECTRICAL

DESCRIPTION	NT16A018B	NT16A024B	NT16A030B	NT16A036B	NT16A042B	NT16A048B	NT16A060B
Compressor Type	Scroll	Scroll	Scroll	Scroll	Scroll	Scroll	Scroll
Ref Charge (oz) R410A	61	63	86	101	104	118	117
Volt –Hz –Phase	208/230 - 60 - 1	208/230 - 60 - 1	208/230 - 60 - 1	208/230 - 60 - 1	208/230 - 60 - 1	208/230 - 60 - 1	208/230 - 60 - 1
Compressor LRA (A)	56.3	62.9	67.8	72.2	109	123.9	152.5
Compressor RLA (A)	9.0	10.9	12.8	14.1	16.7	17	23.7
Fan Blade Dia. / qty blades	24 " / 2	24 " / 2	24 " / 2	24 " / 2	24 " / 2	24 " / 2	24 " / 2
Condenser Fan FLA / HP / RPM rated	0.8 / ½ / 850	0.8 / ½ / 850	0.8 / ½ / 850	0.8 / ½ / 850	0.8 / ½ / 850	1.1 / ½ / 850	1.1 / ½ / 850
MCA	12	14.4	16.8	18.4	21.7	22.4	30.7
Max. Fuse/Breaker (A)	20	25	25	30	35	35	50

LINE SET

LINE SIZES	NT16A018B	NT16A024B	NT16A030B	NT16A036B	NT16A042B	NT16A048B	NT16A060B
Liquid Line	3/8 "	3/8 "	3/8 "	3/8 "	3/8 "	3/8 "	3/8 "
Suction Line	3/4 "	3/4 "	3/4 "	3/4 "	7/8 "	7/8 "	7/8 "

PERFORMANCE

Nom. Size	MODEL	Capacity Btu/h	SEER	EER	SCFM Indoor Air Coil	Ref.	Weight (lb)
1.5 Tons	NT16A018B	19100	15.0	12.5	600	R410A	180
2.0 Tons	NT16A024B	24000	15.0	12.5	775	R410A	180
2.5 Tons	NT16A030B	29400	15.0	12.5	1000	R410A	180
3.0 Tons	NT16A036B	35600	15.0	12.5	1200	R410A	230
3.5 Tons	NT16A042B	41500	15.0	12.5	1350	R410A	230
4.0 Tons	NT16A048B	45000	15.0	12.5	1600	R410A	250
5.0 Tons	NT16A060B	56500	14.5	12.0	1750	R410A	250

NOTE:

ALL NAPOLEON AIR CONDITIONERS SHALL BE INSTALLED WITH PROPERLY MATCHED SYSTEM COMPONENTS LISTED ON AHRI DIRECTORY.

Lined writing area consisting of multiple horizontal lines for text input.

44.1



WOLF STEEL LTD.

24 Napoleon Road, Barrie, Ontario, Canada L4M 0G8

PHONE: 866-820-8686 • FAX: 705-725-1150

Website: www.napoleonheatingandcooling.com

General: hvac@napoleonproducts.com

Technical inquiries: hvacsupport@napoleonproducts.com



Intertek
9700539

