



# Spectiv

## G8NB BEAM DETECTOR USER GUIDE



[www.spectiv.co.uk](http://www.spectiv.co.uk)

### In The Box

---

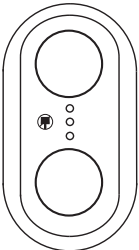

**G8NB Detector Head**

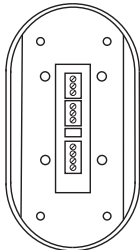

**G8NB Detector Base**

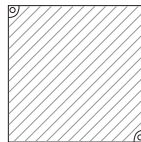

**Reflector**

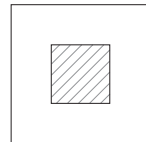

**Short Range Mask**



**User Guide**



**G8NB Test Filter**

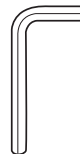

**Hex Key**

# General Information

Position as high as possible, but with a minimum distance of 0.3m from Detector and Reflector to the ceiling.

For detectors approved to UL268 refer to NFPA72 for installation guidance. In such installations, it is advised that the maximum distance of Detector and Reflector from the ceiling must be 10% of the distance between floor and ceiling.

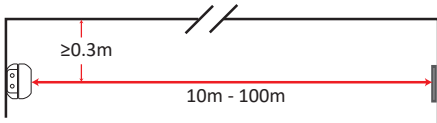

Ensure correct Reflector selected for the appropriate distance.

Mount Detector and Reflector directly opposite each other.

Do not mount the Reflector onto reflective surface.

All installations should comply with local regulations.

Do NOT position Detector where personnel or objects can enter the beam path.

Do NOT install the Detector or Reflector in environments where condensation or icing are likely to occur.

Always maintain at least a 0.5m of clear space around the beam path.

Smoke detectors are not to be used with detector guards unless the combination has been evaluated and found suitable for that purpose.

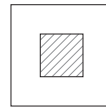
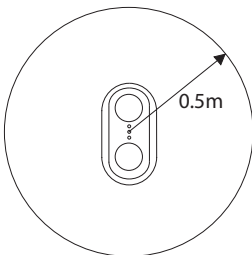

10 - 15m = 1 Reflector + Short Range Mask (may be required)

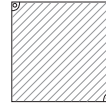

15 - 50m = 1 Reflector

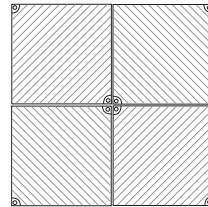

50 - 100m = 4 Reflectors

**NOTE:** To fit the Short Range Mask, remove backing and apply to the Reflector ensuring the centre section leaves the Reflector exposed in that area.



Figure 1

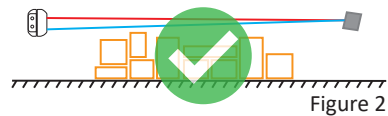

Figure 2

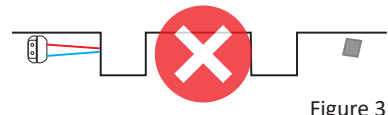

Figure 3



Figure 4

# Wiring

The G8NB outputs the status of the detector using volt-free relays.

To wire a single Detector to a Fire Control Panel (FCP), use the following wiring diagram.

Components not supplied:

1. Alarm Resistor - specified by the FCP manufacturer. For some FCP, this can be a short-circuit.
2. End Of Line (EOL) component - supplied by FCP manufacturer.

After installation, check operation of Fire and Fault connections to the FCP - see page 7.

Apply a voltage [V+] to 'Ext Reset' contact for at least 2 seconds to clear a latched fire condition - see page 7 for latched Fire setting.

CAUTION: For system monitoring - Do not use looped wire under any terminals. Break-wire run to provide monitoring of connections.

Note: Only plastic conduit to be connected to the detector and secured via the selected knock out.

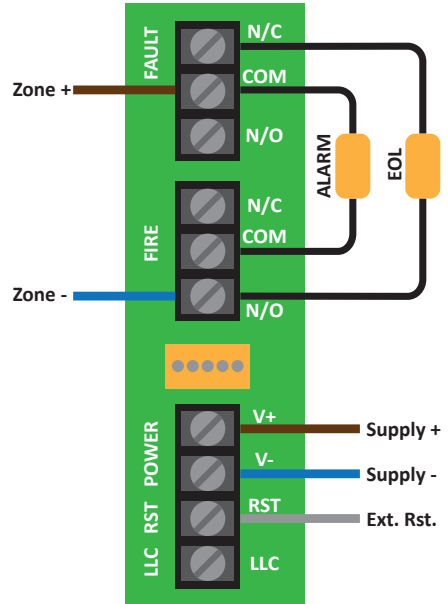

# Mounting & Positioning

1. Mount Detector Base onto a solid, structural surface.
2. With the Detector Head Cover removed, plug the Detector Head cable into the connector on the PCB of the Detector Base.
3. Fix the Detector Head onto the Detector Base using the fixing bolts.

**NOTE:**

Detector Base must be mounted onto a solid surface, such as a structural wall or girder.

Appropriate hardware (not supplied) must be used to mount securely.

# User Interface and Settings

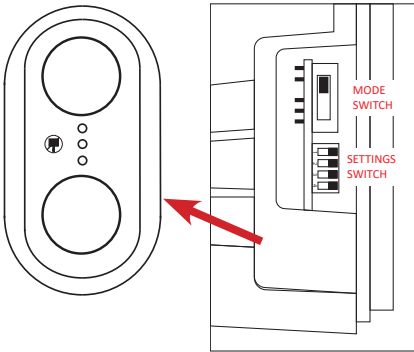

Remove the Front Cover to access the MODE SWITCH and SETTINGS SWITCHES which are located to the side of the unit.

Select the desired Threshold and Latching mode before alignment.

**Do NOT remove the detector from the wall when accessing switches.**

**IMPORTANT:** If any of the settings are changed after initial alignment, the detector must be re-aligned.

Repeat the full alignment procedure.

## MODE SWITCH

TARGETTING MODE

ALIGNMENT MODE

OPERATING MODE

## SETTINGS SWITCH

		SW-1	SW-2	SW-3	SW-4
50m	OFF	X	X	X	
100m	ON	X	X	X	
Latched	X	ON	X	X	
Non	X	OFF	X	X	
25%	X	X	ON	OFF	
35%	X	X	OFF	ON	
50%	X	X	OFF	OFF	
75%	X	X	ON	ON	

OFF

ON

Distance between Reflector and Detector (m)	Distance between Reflector and Detector (ft)	Acceptable Alarm Threshold
10m - 14m	33ft - 46ft	25%
14m - 22m	46ft - 72.5ft	25%, 35%
22m - 32m	72.5ft - 105ft	35%, 50%
32m - 50m	105ft - 164ft	50%
50m - 100m	164ft - 328ft	75%

## Alignment - Targeting Mode

Slide the Mode Switch to the top position to start Targetting Mode. The purpose of this is to achieve at least a solid Red LED by adjusting the Alignment Thumb-wheels to steer the beam onto the Reflector. The minimum required to progress onto Alignment Mode is a solid Red LED. At shorter operating ranges, it may be possible to illuminate the Red, Amber and Green LEDs.

**Weak Red LED:** No signal or a very weak signal. Continue to adjust the beam alignment until the Red LED increases or the Amber LED is illuminated.

**Solid Red LED:** Beam is receiving a low amount of reflected signal. Continue to adjust the beam alignment until an Amber LED is illuminated. If this is not possible, move onto Alignment mode. Note: Solid Red LED is the minimum required signal to move onto Alignment Mode.

**Amber LED:** Beam is receiving a medium amount of reflected signal. Continue to adjust the beam alignment until a Green LED is illuminated. If this is not possible, move onto Alignment mode.

**Green LED:** Beam is receiving a high amount of reflected signal. Move onto Alignment mode. Before moving onto Alignment mode, it is advised to cover the reflector fully with a non-reflective object. A weak Red LED should illuminate to indicate no signal is being received from the Reflector. If the LEDs do not change, then the beam is receiving a signal from another surface. Repeat the Targetting Mode to adjust the beam onto the reflector.

### TIP:

If the LEDs go out when the Reflector is covered, this means the beam is seeing the Reflector. If not, check for other reflective surfaces and repeat Targetting Mode.

# Alignment - Alignment Mode

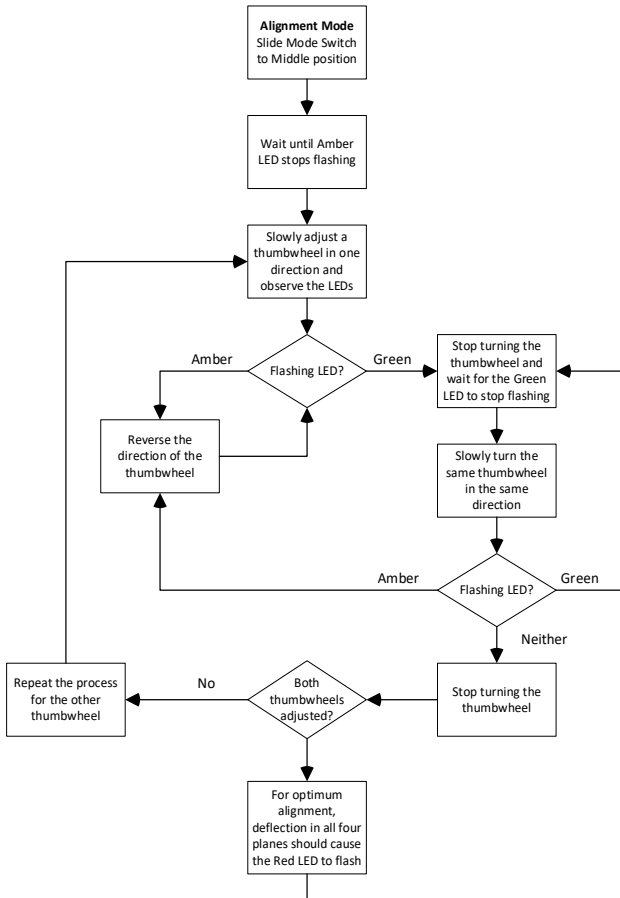

Once the Thumb-wheels have been adjusted and optimum alignment has been proven, the beam is now aligned and Operating Mode can be selected.

# Alignment - Operating Mode

---

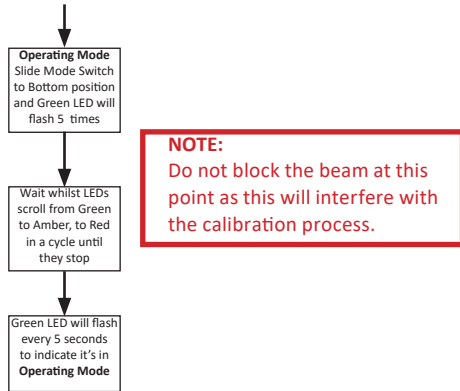

**NOTE:**

Once Aligned, Fire and Fault relays will go to normal state, and the Detector will flash its status indicator green every 5 seconds.

The G8NB Detector is now operational.

It is advised to test the Detector to ensure it is operating and connected to the Fire Control Panel correctly.

## Status Indications

---

**Normal Operation**

During normal operation the Green Detector LED will flash once every 5 seconds, and both Fire and Fault relays will be in their normal position.

**Fire Condition**

In a Fire state, the Red Detector LED will flash once every 2 seconds and the Fire relay will change state.

**Fault Condition – Rapid Obscuration**

If the line of sight of the G8NB has been blocked, causing the signal level to rapidly drop close to 0%, the Amber LED will flash once every 2 seconds and the Fault relay will change state.

**Fault Condition – Dirty Lens**

The G8NB compensates for dust on the lenses and reflectors to prevent false alarms. If this compensation reaches its limit, the Amber LED will flash once every 5 seconds and the Fault relay will change state. At this time, the lenses and reflectors must be cleaned and the G8NB re-aligned.

# Testing and Maintenance

---

## Testing

After installation or cleaning it is recommended that a Fire and Fault test is performed. This can be done in one of two ways:

### Testing Option 1. G8NB Test Filter (G8NB-TF).

Fire Test: Cover the Receiver Lens with the G8NB Test Filter to where the obscuration indicator on the Filter matches what the G8NB is set to. The G8NB will indicate Fire after 10 seconds.

Fault Test: Cover the receiver completely within 2 seconds using the 100% obscuration section of the G8NB Test Filter. The G8NB will indicate Fault after 10 seconds.

### Testing Option 2. Opaque, Non-reflective Material (E.g. cardboard)

Fire Test: Cover the reflector slowly so that it takes longer than 5 seconds to cover. The G8NB will indicate Fire after 10 seconds.

Fault Test: Cover the reflector completely within 2 seconds. The G8NB will indicate Fault after 10 seconds.

## Cleaning

The G8NB automatically compensates for dust build up by changing its Automatic Gain Control (AGC) level. If the AGC limit has been reached, the G8NB will indicate a Fault by flashing the Amber LED every 2 seconds along with a Fault output on the relay. The G8NB must be cleaned and re-aligned to clear the Fault.

To clean use a soft, lint-free cloth to wipe away any dust from the lenses and reflectors. After cleaning, the G8NB must be re-aligned to reset the AGC and ensure the best possible signal.

### Latched and Non-Latched Fire

The Fire state will automatically clear once the signal strength has recovered above the threshold level unless Latched Fire has been selected.

To clear a Latched Fire, apply [V+] to the External Reset [RST] for longer than 2 seconds. Note: the cause of the fire condition must have also cleared.

# Technical Support

---

If you encounter any issues or have questions about our products, our Technical Support team is here to assist you. In the first instance, please contact the distributor whom you purchased the product. If further assistance is required, you can reach out to us through the following channels:

#### Email:

For detailed inquiries or to report issues, please email us at [technical@spectiv.co.uk](mailto:technical@spectiv.co.uk). Our team will respond within 24 hours.

#### Phone:

For immediate assistance, you can call us at +971 (0)58 5703382. Our support line is available from 9 AM to 6 PM (GMT+4), Monday to Friday.

#### WhatsApp:

You can also message us on WhatsApp at +971 (0)58 5703382 for quick support. Our WhatsApp support is available 24/7

# Technical Information

G8NB Parameters		Minimum	Typical	Maximum	Unit
Operating Voltage		15	24	32	V DC
Operating Current		15	20	42	mA
Operating Current – Alignment Modes		-	-	55	mA
Alarm Current		25	33	55	mA
Fault Current		3	10	30	mA
Response Thresholds (25%, 35%, 50%, 75%)		25	35	75	%
Delay to Alarm		-	10	-	s
Delay to Fault		-	10	-	s
Operating Distance (Separation between Detector and Reflector) (4 reflectors required for >50m, >164ft)		10	-	100	m
Rapid Obscuration Fault Threshold		-	85	-	%
Maximum angular alignment range of detector		-	-	±4.5	Deg
Optical Wavelength		-	850	-	nm
Operating Temperature		-	-20 -4	+55 +131	°C °F
Storage Temperature		-40 -40	-	+55 +185	°C °F
Relative Humidity (non-condensing)		-	-	93	%RH
IP Rating		-	IP40	-	IP
Fire & Fault Relays (VFCO) - Contact voltage		-	-	30	V DC
Fire & Fault Relays (VFCO) - Contact current		-	-	1	A
Cable Gauge		22	-	16	AWG
Housing Flammability Rating		-	UL94 V0	-	-