

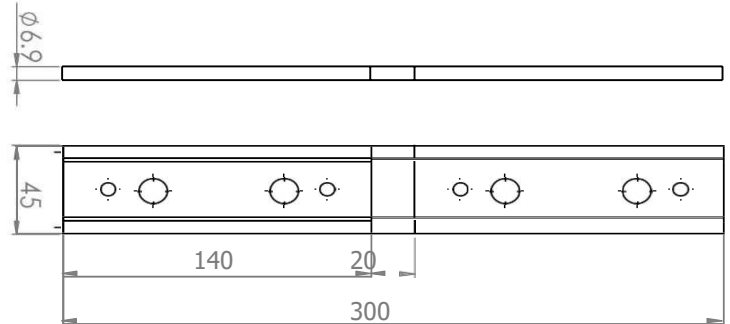

PRODUCT CODE: CGT1  
PUBLICATION DATE: May 2021 v1.00

## Vertical Control Gap Tie

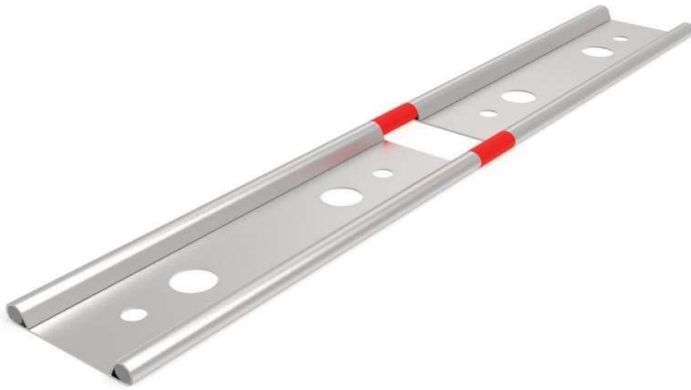

### DESCRIPTION

Vertical control gap tie for brick block work. This tie will retain masonry integrity Against lateral wind loads, sleeves will absorb differential movement.

### FEATURES

- Clay brick / block work
- Tested to a control gap of 40mm
- Universal applications
- Australian design & tested as/nzs 2699.2:2020

### CORROSION CHARACTERISTICS

Galvanised Z600 (R2)  
Hot dipped galvanising (R3)  
Stainless steel 316L (R4)  
Conforms to corrosion resistance set by AS/NZS 2699.2:2020 / AS 3700.

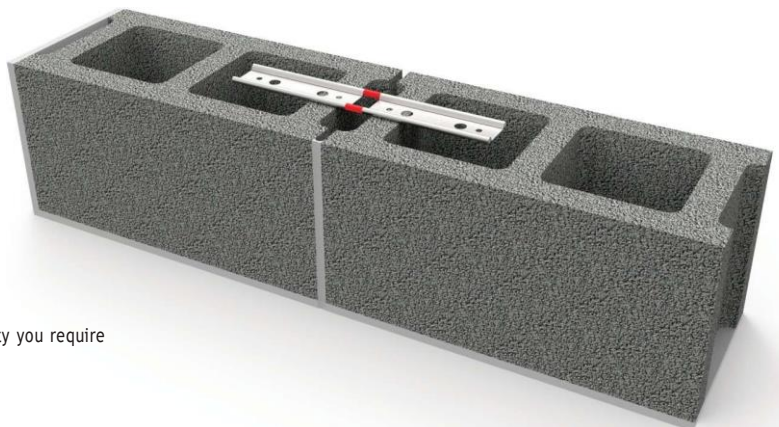

### ORDERING INFORMATION

When ordering please supply use with the part number and quantity you require

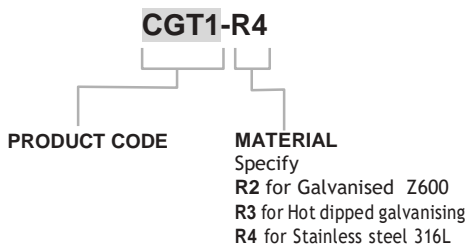

Datasheet



FOR SALES ENQUIRIES, PLEASE CONTACT ROGERS CS (QLD) OR SALES@ROGERSCS.COM.AU

UNIT 2, 19 HOOK STREET, CAPALABA QLD 4157 | T: 07 3823 2316 | [HTTPS://ROGERSCS.COM.AU](https://ROGERSCS.COM.AU)