

PRODUCT CODE: **CGT4**
 PUBLICATION DATE: **May 2021 v1.00**

Horizontal Control Gap Tie

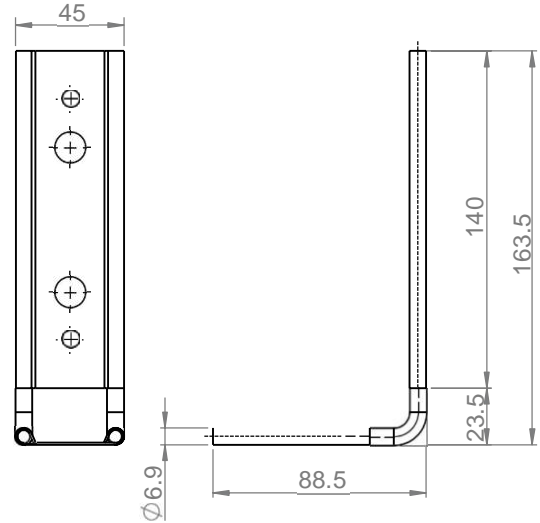

Datasheet

DESCRIPTION

Horizontal control gap tie for brick and block work. This tie will retain masonry integrity Against lateral wind loads, sleeves will absorb differential movement.

FEATURES

- Clay brick / block work
- Tested to a control gap of 40mm
- Universal applications
- Australian design & tested as/nzs 2699.2:2020

FIXING REQUIREMENTS

Fixed with approved fasteners, contact us with your project requirements.

CORROSION CHARACTERISTICS

Galvanised Z600 (R2)
 Hot dipped galvanising (R3)
 Stainless steel 316L (R4)
 Conforms to corrosion resistance set by AS/NZS 2699.2:2020 / AS 3700.

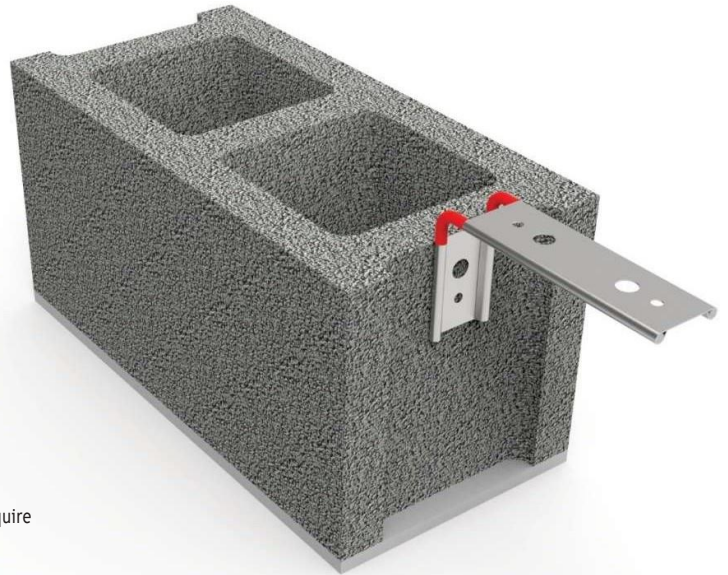

ORDERING INFORMATION

When ordering please supply use with the part number and quantity you require

CGT4-R4

PRODUCT CODE

MATERIAL

Specify
 R2 for Galvanised Z600
 R3 Hot dipped galvanised
 R4 for Stainless steel 316L



FOR SALES ENQUIRIES, PLEASE CONTACT ROGERS CS (QLD) OR SALES@ROGERSCS.COM.AU

UNIT 2, 19 HOOK STREET, CAPALABA QLD 4157 | T: 07 3823 2316 | HTTPS://ROGERSCS.COM.AU