

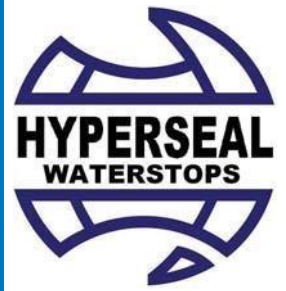

HYPERSEAL D SERIES

PVC Waterstop Plate Technical Data Sheet



D-150
D-200
D-230

Description

Hyperseal D is a polyvinyl chloride (PVC) waterstop system which provides a physical barrier to seal in-situ concrete joints. All three Hyperseal D profiles work by increasing the displacement water needs to travel through the joint. The contour of each profile also ensures the waterstop is secure against structural movement and induces tensions across the whole waterstop section.

Profiles

- **Hyperseal D150** – centrally placed waterstop for construction joints.
- **Hyperseal D200** – centrally placed waterstop for construction or expansion joints.
- **Hyperseal D230** – externally placed waterstop for construction or expansion joints.

Note: Hyperseal D profiles can be also produced as a dual waterstop system which consists of a hydrophilic rubber being cast into the waterstop profile. This is known as the Hyperseal DX Series. For more information, please contact your nearest distributor.

Typical Areas of Application

- Basements and slab on grade
- Elevator pits and equipment pits
- Roof decks and podium areas
- Parking structures
- Swimming pools and water features
- Water towers, reservoirs and water storage tanks
- Dams, culverts, canals and spillways
- Tunnels, underground vaults, etc

Advantages

- No shelf life
- Extensive warranty period
- Continuous on-site welded system
- Range of profiles available to suit almost any application
- Sustains effective seal in submerged environments
- Use in salt or fresh water
- Safe for drinking water
- Non-toxic and zero VOC



Physical Properties

Form:	Extruded PVC Profiles
Colour:	• Green • Black
Elongation:	250% min
Tensile strength:	120kg/cm ²
Hardness:	Shore 'A' 65
Hydrostatic resistance:	600kPa (60m head)
Service temperature range:	-30°C to 60°C
Melting temperature:	230°C approx
Chemical resistance:	Alkali - good Brine - excellent

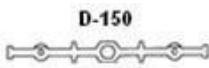
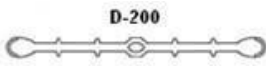
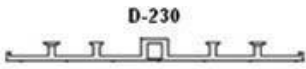
Profiles:	
	5mm x 150mm x 20m roll
	7mm x 200mm x 15m roll
	5mm x 230mm x 15m roll

Accessories:

Jointing jigs, welding heat-rods, fastening clips, straight joiners, Hyperseal DPS-200 sealant.





Typical Positioning

Design Criteria

Special consideration needs to be made when using PVC waterstops as the cross-sectional area could interrupt reinforcing bars, pipe penetrations and the like.

Concrete placement is vital as wrong positioning and excessive movement of the waterstop could render the system ineffective.

Concrete must be fully compacted around the waterstop to ensure no voids or porous areas remain.

For positing and formwork details, please refer to our installation guide.

Application Instructions

Welding Instructions:

1. For positioning and full welding details, please refer to our installation guide.
2. Measure the length of waterstop required or feed the waterstop into position. Before trimming, allow approx 5 mm to each mating end to allow for melting.
3. Clamp the two ends into their respective sides of the jointing jig, with approximately 10 mm projecting and engage the guide rods.
4. Plug in the welding blade and allow to warm up. Using a small off-cut of waterstop, check that the blade reaches a temperature sufficient to melt the PVC. Ensure the area is well ventilated.
5. When the blade is at melt temperature, place it on edge of the guide rods of the jig between the mating ends of the waterstop. Press the waterstop firmly against either face of the blade until a molten bead of PVC approx 3mm thick appears along the length of the blade. Slide the jig apart, remove the heating blade and push the waterstop back together holding under pressure for a while which allows the molten PVC to fuse together. Allow to cool before proceeding.

Straight Joiner Instructions:

Alternatively, straight joiners can be used to join lengths.

1. Caulk each insert side of the straight joiner with Hyperseal DPS-200 sealant.
2. Squeeze the PVC waterstop into each side and ensure all gaps are completely filled with the sealant.
3. Once Hyperseal DPS-200 has cured, installation can continue.

Safety

Before using or handling materials, please read all relevant Material Safety Data Sheets (MSDS).

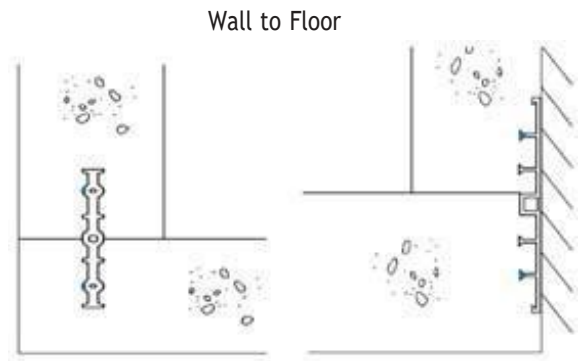
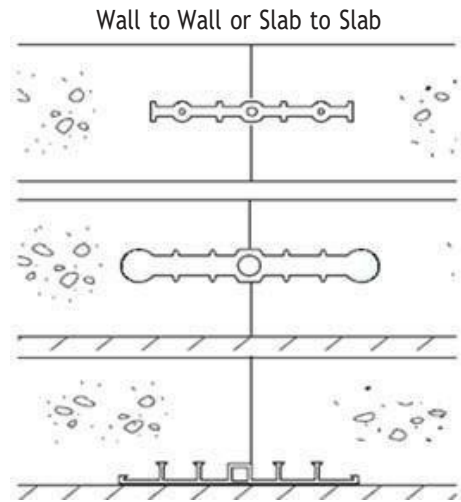

Warranty

The seller warrants that at the time of shipment its products are free from manufacturing defects and, when applied in accordance with the current specification and application instructions, will perform as so stated in its product literature. Project specific warranties are available on request. Please consult your nearest distributor for further information.

Product Disclaimer

The technical details, recommendations and other information contained in this data sheet are given in good faith and represent the best of our knowledge and experience at the time of printing. It is your responsibility to ensure that our products are used and handled correctly and in accordance with any applicable Australian Standard, our instructions and recommendations are only for the uses they are intended. Hyperseal Waterstops does not accept any liability either directly or indirectly for any losses suffered in connection with the use or application of the product. We also reserve the right to update information without prior notice to reflect ongoing research and development programs. The supply of our products and services is also subject to certain terms, warranties and exclusions, which may have already been disclosed to you in prior dealings or are otherwise available to you on request. You should make yourself familiar with any relevant items.

Technical Support

For any additional information not expressed in this document, please contact us via the details below.

