

VRH AND RHC RANCH REINING PATTERN 2

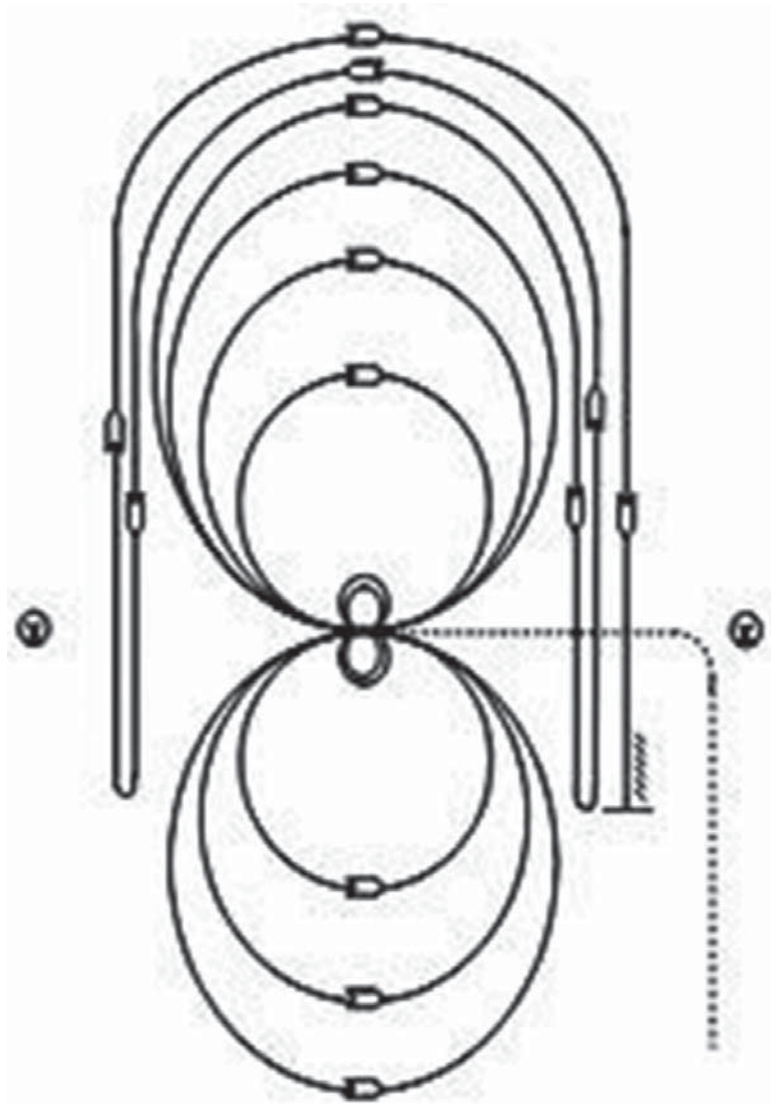

Mandatory Markers along Fence or Wall The judge shall indicate with markers on arena fence or wall the center of pattern.

Ride pattern as follows: Trot to center of arena and stop or walk before departure.

- 1.** Beginning on right lead, complete two circles to the right - the first one large and fast; the second one small and slow. Stop at center.
- 2.** Complete 4 spins to the right. Hesitate.
- 3.** Beginning on left lead, complete two circles to the left - the first one large and fast; the second one small and slow. Stop at center.
- 4.** Complete 4 spins to the left. Hesitate.
- 5.** Beginning on the right lead, complete a large fast circle to the right and change leads at center of arena. Complete a large fast circle to the left and change leads at center of arena.
- 6.** Begin a large fast circle to the right, but do not close this circle. Run down the right side of the arena, past the center marker, and do a left roll back at least 20 feet from the wall or fence.
- 7.** Continue back around the previous circle, but do not close this circle. Run down the left side of the arena, past the center marker, and do a right roll back at least 20 feet from the wall or fence.
- 8.** Continue back around previous circle, but do not close this circle. Run down right side of the arena, past the center marker, and do a sliding stop at least 20 feet from the wall or fence. Back up at least 10 feet. Hesitate to show completion of pattern.