

3



DOLTRA III



3

PALTA III

**TWO SOULS.
ONE BIKE.
ZERO REGRETS.**



PALTA III

B
BASSO

**OTHERS OBSERVE, WE EXPERIENCE:
OTHERS DO GRAVEL, WE DO PALTA**

While others polarized their gravel offer to chase specific purposes, we stayed true to our own path. Because for us, gravel isn't a choice between racing and exploring, it's both. The Palta is the singular answer to a fragmented market, a unique blend of performance and versatility packed into one iconic frame at its third generation.

#WeDoPalta



COLORWAYS THAT INSPIRE

Palta is available in three meticulously crafted colorways, each curated to captivate the eye and reflect the bike's distinct gravel character.



DEEP ORBIT



PURPLE DUST



CARBON CHROME



GALAXY DREAM



GRAVEL

WAS BORN AS A MIDPOINT
BETWEEN ROAD CYCLING AND MTB.

RACING

ROAD
CYCLING



MTB

ADVENTURE

NOW HAS BECOME ITS OWN **ENTITY**,
ITS OWN **CULTURE** AND ITS OWN **SCENE**.

The latest market offering has imposed a difficult choice upon the rider. Choose between a **PERFORMANCE BIKE** that is not suited for adventures or an **ADVENTURE BIKE** that is not performing well enough to have FUN in gravel races.

Most of the cyclist
ARE NOT DOING ONLY ONE ACTIVITY
but switch between racing and adventures.

The result is a choice that makes them uncomfortable and with the fear of missing out.





**SPONSORED RACERS,
END UP CHOOSING A BIKE THAT
WASN'T DESIGNED
FOR THE PURPOSE
BECAUSE THE RACING BIKE
DOES NOT MEET
ALL THE FEATURES:
FOR EXAMPLE TIRE CLEARANCE.**

PALTA III DOESN'T FORCE YOU TO CHOOSE AND LIVE WITH THE CONSEQUENCES BUT ITS RATHER A VERSATILE BIKE ABLE TO COVER MOST OF THE APPLICATION.



COMFORTABLE AND CAPABLE GRAVEL RACING BIKE

PREMIUM AND FAST ADVENTURE GRAVEL BIKE

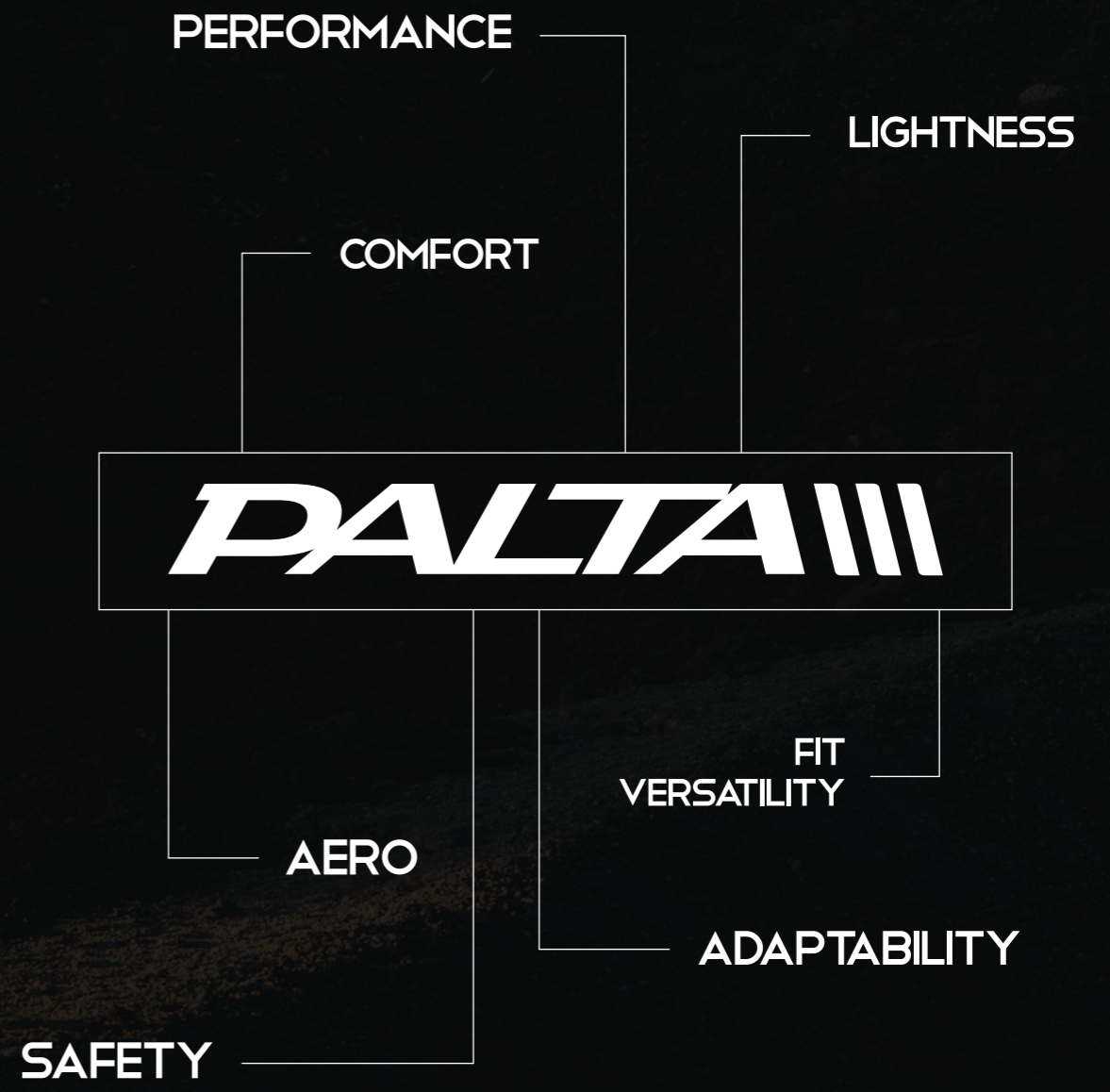

TIMELINE

FROM THE ORIGIN
TO THE 3RD GENERATION



2018
LAUNCH
OF THE FIRST
BASSO PALTA

NAME ORIGIN

—
“PALTA”
comes from a local Veneto dialect
(Italy), meaning “mud”.

Symbolizing its
off-road capability.



2021
INTRODUCTION
OF THE
PALTA II

MARKET IMPACT

—
OVER 7000
Basso Paltas
currently in the market.



10/02/2026
ARRIVAL
OF THE
PALTA III

REFINEMENT THROUGH EVOLUTION

—
Each new edition
IMPROVES AND REFINES
the original concept, without
changing its essence.

ITALIAN DESIGN
CRAFTED INTO A
HIGH-PERFORMANCE
FRAMESET

DESIGN APPROACH

1. Visual Consistency

Basso bikes share a cohesive design language across all models, ensuring visual harmony while preserving each bike's specific purpose.

2. Brand Identity

Basso's design embodies Italian craftsmanship, elegance, and innovation, with every detail expressing a distinctive and unmistakable identity.

3. Evolutionary Design

Basso evolves through refined innovation, balancing modern technology with the timeless elements that define its identity.

4. Customer Recognition

Consistent, timeless design makes Basso bikes instantly recognizable, building trust, loyalty, and a strong connection with riders.

5. Functional Integration

Design follows function: every aesthetic update is purpose-built to enhance performance without compromise.

DESIGN DETAILS & CONTAMINATIONS

Core features kept from the original generation, alongside influences from other models



HIGH SEAT STAY ATTACHMENT ALONG THE SEAT TUBE
 Improves vertical compliance, comfort, and traction while preserving lateral stiffness and overall pedaling efficiency.

DIAMOND SHAPE TUBES
 Optimized tube sections reduce weight while maintaining stiffness, placing material only where structurally necessary.

ADVANCED FRONT FORK ARCHITECTURE
 The unique geometry of the advanced fork stays confer both a more precise handling as well as vibration dampening to the ride quality.

SV CLEAN FORK DROPOUTS
 No visible threads for a refined look

SV DOWNTUBE
 Aerodynamically optimized to reduce frontal area, enhance airflow management, and maximize stiffness-to-weight efficiency.

“ELBOW” DESIGN
 Distinctive rear dropout that provide vertical flex and improved comfort while maintaining torsional stiffness

WHY CHOOSE
WHEN YOU
CAN HAVE
BOTH?

PERFORMANCE METRICS

Palta is not just a gravel bike. It is a performance-driven machine engineered to redefine speed and fun. Drawing inspiration from the SV's "Sempre Veloce" philosophy, the Palta translates racing DNA into a versatile platform where aerodynamics meet off-road compliance.

LIGHTWEIGHT

Material of choice:
TORAYCA™ Carbon

T800: 70%
M40JB: 20%
T700: 10%



SEATPOST
weight: **180 g**
(380 mm length)



FRAME
weight: **970 g**
size M



STRATO STEM
weight: **250g** (+/- 3%)



CARBON GRAVEL
HANDLEBAR
weight: **250g** (+/- 3%)



FUGA HANDLEBAR
weight: **300g** (+/- 3%)



LEVITA HANDLEBAR
weight: **330g** (+/- 3%)

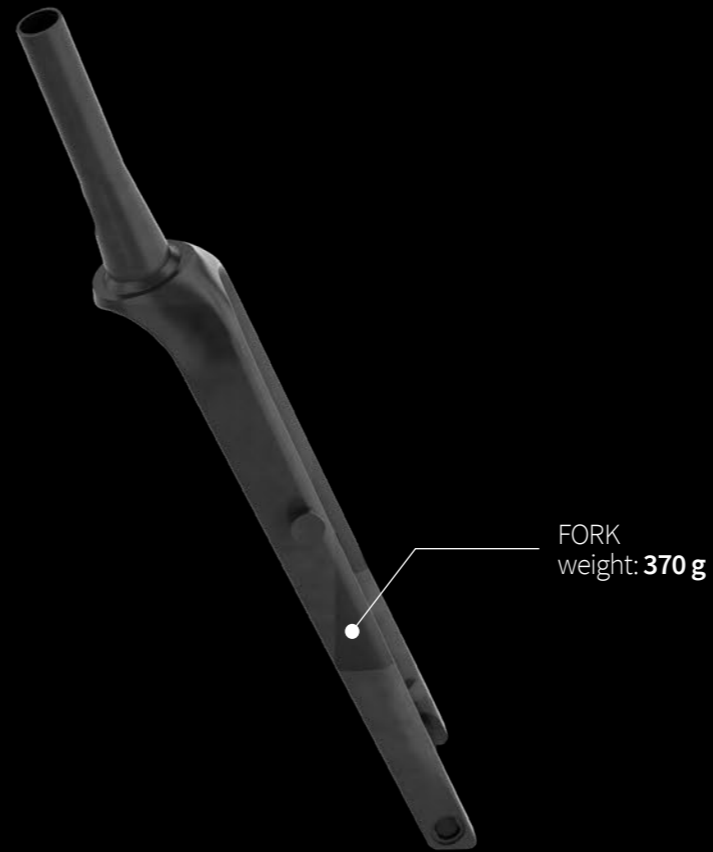

FORK
weight: **370 g**

OPTIMIZED POWER TRANSFER & CONTROL

The Palta's carbon layup has been re-engineered **to maximize Pedal Efficiency.**

By increasing Bottom Bracket and Rear Triangle stiffness, we've ensured a more direct power transfer for explosive acceleration and climbing.

Conversely, the Head Tube stiffness has been reduced to enhance handling and comfort, providing a more fluid steering feel and superior vibration dampening on rough terrain.

ENHANCED AERODYNAMICS

The Palta delivers a **18% reduction** in frontal aerodynamic impact. Leveraging Basso's high-performance road R&D, the frame's cross-sections, specifically the Down Tube, have been optimized to minimize drag and streamline airflow.

This evolution significantly **reduces aerodynamic resistance**, ensuring that **off-road versatility** and **high-speed efficiency** are achieved without compromise.

BB Stiffness

Units: Nm | Force 36kg

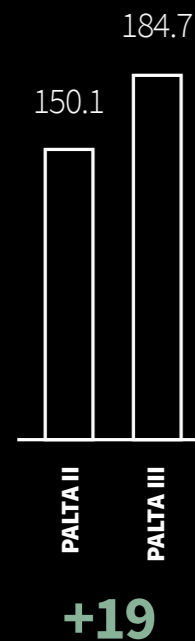

Rear Triangle Stiffness (at the axle)

Units: Nm | Force 21kg



HT Stiffness

Units: Nm | Force 56kg

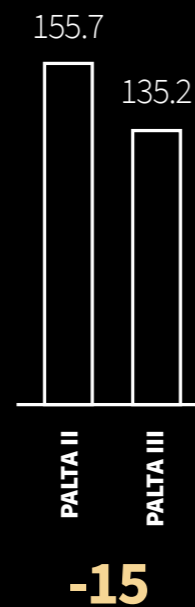

The result: a more direct power transfer and precise handling even on challenging gravel.

PALTA II

PALTA III

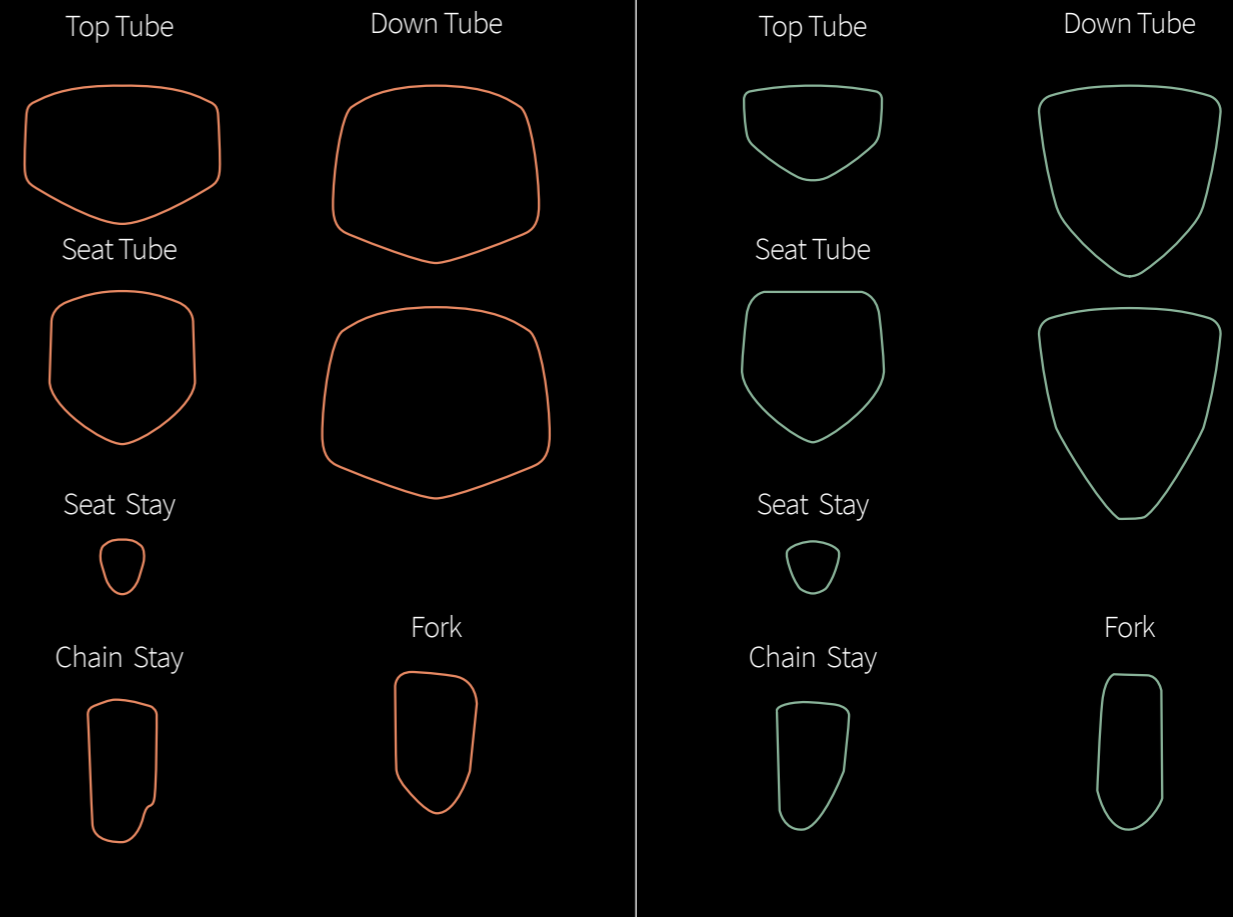

A truncated airfoil tube design (**KAMM TAIL**) is applied across all tube sections to improve aerodynamic efficiency



VERSATILE
FITTING OPTIONS:
PRIORITIZING RIDER
ERGONOMICS FOR
PEAK PERFORMANCE



COMFORT METRICS

Beyond frame engineering, the rider remains the most critical variable. We offer extensive adjustability to ensure riding comfort and precision fit. This tailored approach optimizes power output for a superior gravel experience.

TIRE CLEARANCE COMFORT MEETS MODERN DESIGN

Compatible with tires up to **50mm** at the rear and **52mm** at the front, Palta enhances gravel performance by allowing lower inflation pressures for improved vibration absorption and long-distance comfort.

The increased air volume delivers superior traction and stability on rough, technical terrain while maintaining absolute confidence at higher speeds.

3B CLAMP SYSTEM GEN II VIBRATION ABSORPTION REDEFINED

The second-generation 3B Clamp System (*patent pending*) is designed to minimize road vibrations, delivering a smoother, **more comfortable ride over any distance.**

Featuring a completely **hidden fixing solution** that remains invisible on the frame, it seamlessly blends technological innovation with aesthetic appeal.

The system is lightweight, robust, and integrates three screws, further enhanced by the vulcanization of the steel plank.

This unique Basso solution gives the 3B Clamp an **anti-vibration function**, significantly improving comfort and elevating the riding experience on rough, uneven surfaces.

STORAGE COMPARTMENT

The frame features a **dedicated downtube storage compartment**, elegantly concealed by a carbon-painted cover that maintains the bike's sleek aesthetics. This internal space is designed for maximum utility, housing **two rugged, anti-abrasion and waterproof internal bags** to organize tools and essentials.



Access is quick and secure thanks to the **Fidlock® magnetic latch** with a mechanical locking system, ensuring the compartment remains firmly closed even on the roughest terrain, yet stays easy to open when needed.

EXTRA MOUNTING POINTS

In addition to the traditional bottle cage mounts on the downtube and seat tube, Palta comes with **several extra mounting points**.

The frame features **two extra mounting points** on the top tube for a bolt-on bag or additional bottle, complemented by **three points** positioned underneath for a customized frame bag or other accessories. **Two additional mounting points** under the downtube provide a secure solution, ensuring you are fully equipped for any distance.

EVERY DETAIL ENGINEERED FOR THE PERFECT RIDE

At Basso, we believe that performance is only as powerful as the comfort it provides. Palta redefines comfort in cycling, integrating advanced geometry, innovative features, and ergonomic design to ensure that every ride feels as good as it performs.

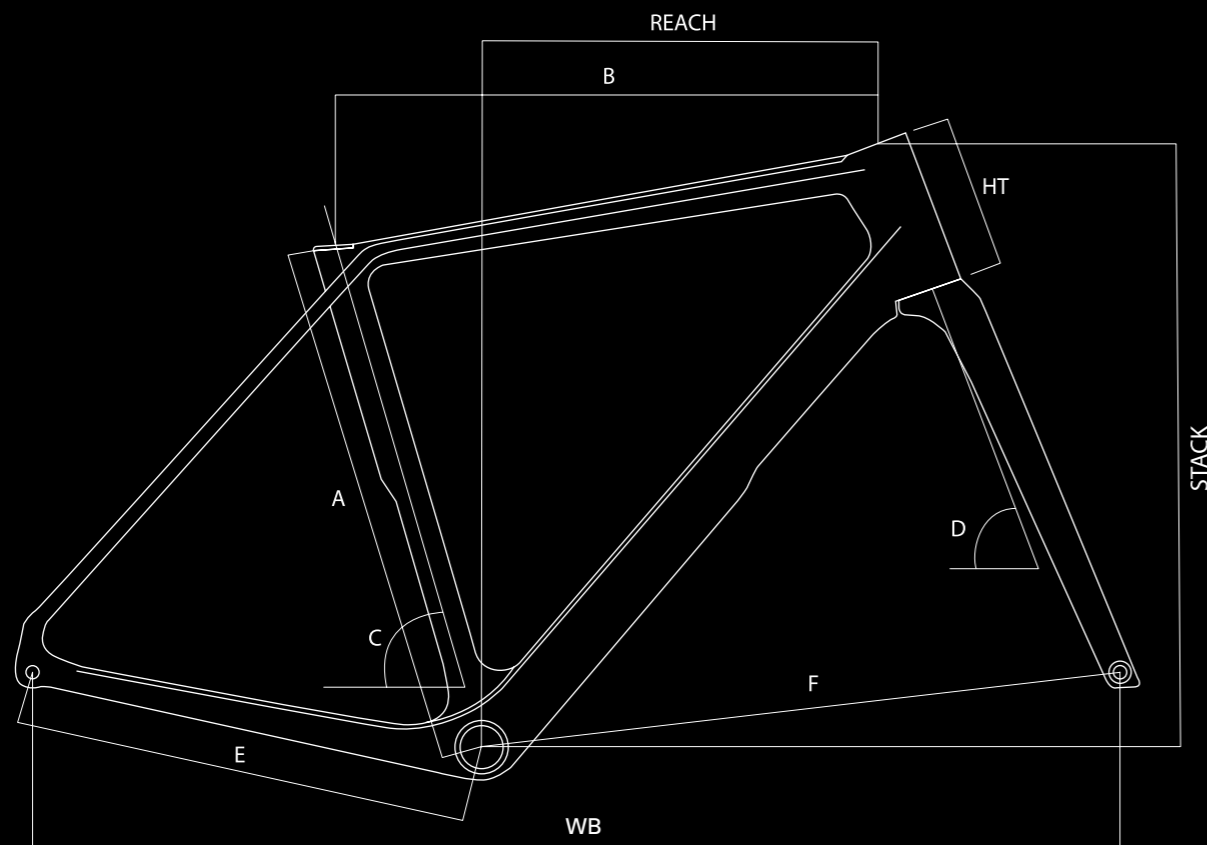

GEOMETRY AND FIT: PRECISION MEETS VERSATILITY

Six frame sizes with overlapping ranges to ensure flexibility and a tailored fit for every rider.

High stack and sloping geometry, for perfect fit, control and resistance on long distances.

		XS	S	M	L	XL	XXL
A	Seat Tube (mm)	410	450	490	520	550	580
B	Top Tube (mm)	496	515	540	560	578	595
R	Reach (mm)	354	362	373	385	398	405
S	Stack (mm)	530	550	570	590	605	620
C	Seat Tube Angle (degree)	75	74,5	73,7	73,5	73,5	73
D	Steering Tube Angle (degree)	68	69,5	70	71	71	71,5
HT	Headtube (mm)	112	127	146	163	179	193
E	Chain-stay Length (mm)	430	430	430	430	430	430
WB	Wheel Base	1012	1013	1027	1035	1054	1060
F	BB to Fork Length (mm)	592	594	607	615	634	640

STRATO STEM

Evolution of the Paradigma Stem.
Improved clamping system for greater stability and reliability



Weight: 250 g
Material: Forged 6061 alloy
Stack height: 33 mm
Angle: -8°
Lengths: 80 to 120 mm
(in 10 mm increments)

INTEGRATED HEAD UNIT MOUNT

Available in **two lengths**:
Standard and Explorer – ideal for use with handlebar bags and under-mounted lights
Compatibility: GoPro, Wahoo, Garmin (including 1050)



BASSO CARBON GRAVEL HANDLEBAR

Slimmed central section to accommodate thicker bar tape
while maintaining a comfortable overall diameter.

Weight: 250 g (Size 440 mm)

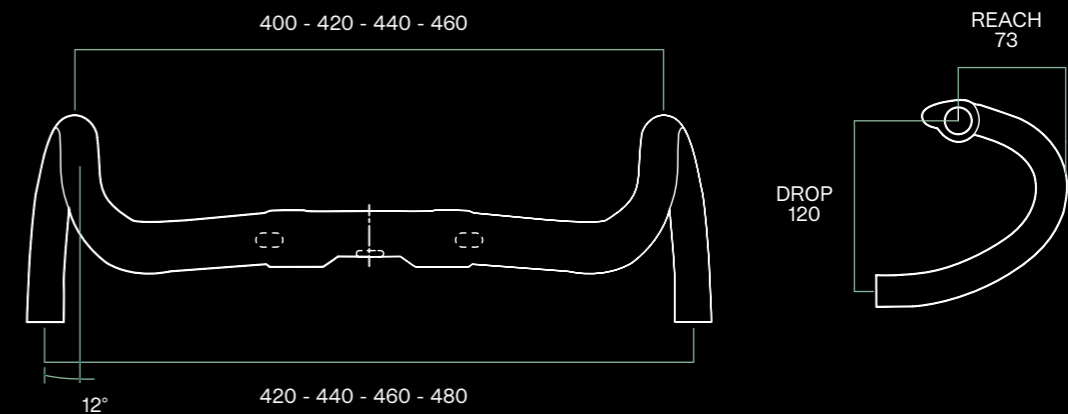
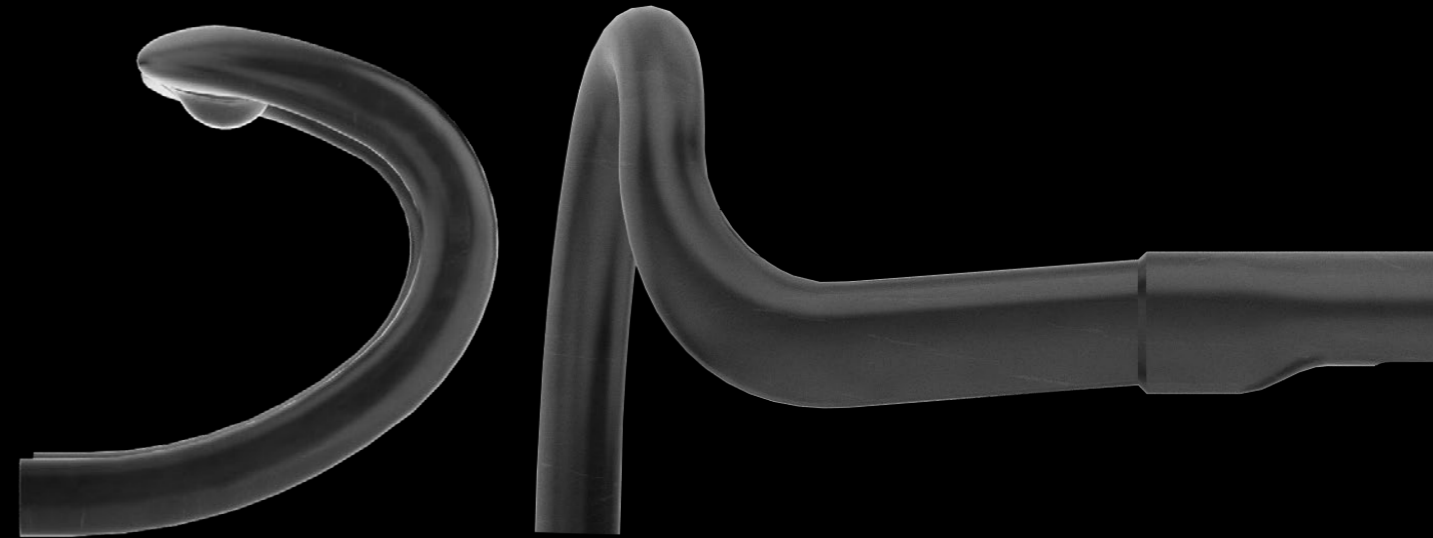

BASSO CIMA HANDLEBAR TAPE (4.5 mm)

Extra padding for long-distance comfort and
enhanced vibration damping.



HANDLEBAR INNOVATION FUGA & LEVITA

To meet the diverse needs of riders, we introduce
Fuga Integrated Handlebar
300 g weight (+/- 3%)

For those who prefer a more classic bike fit, the
Levita Integrated Handlebar,
offers seamless compatibility and
additional customization options
330 g weight (+/- 3%)

Optimized for aerodynamic performance fit on the bike

Designed for narrow-shouldered riders

Features a 1° back sweep and downsweep for enhanced comfort and neutral wrist position

Ergonomically shaped tops for better hand positioning

Short 65mm reach for lever/handlebar integration

Compatible with all Basso EcoSystem accessories

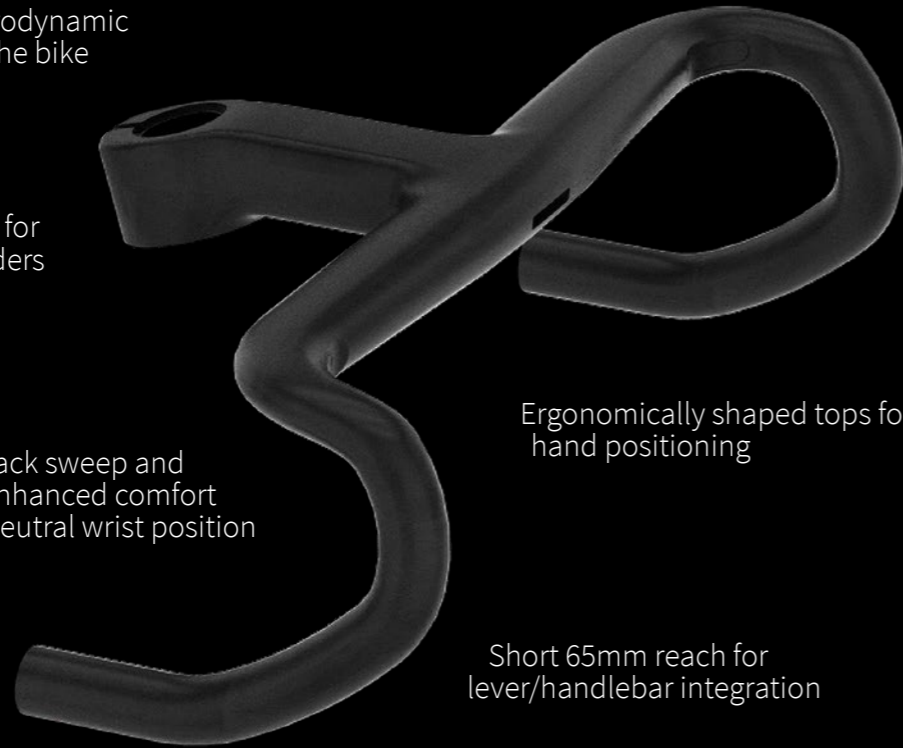

Handlebar tape integration

Compatible with all Basso EcoSystem accessories

Levita is designed to manage and improve both aesthetics and functionality in a crafted carbon integrated stem and bar system.

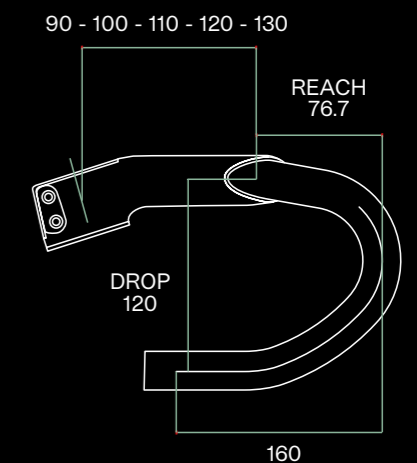
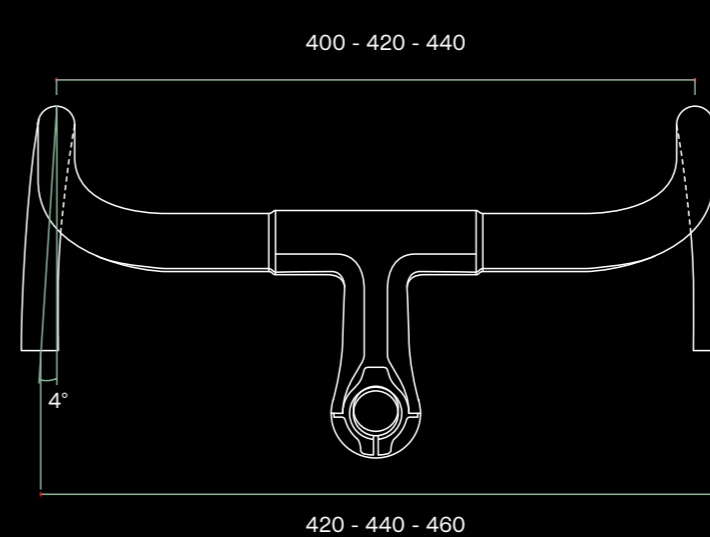
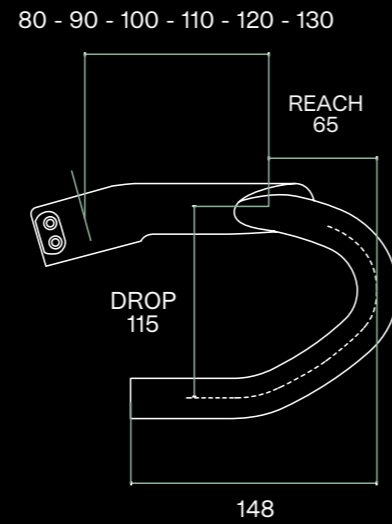
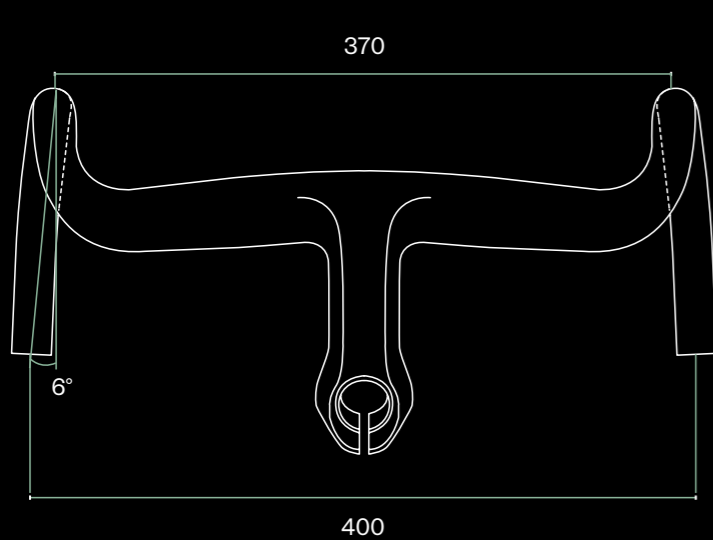

SEATPOST BUILT FOR COMFORT

The **Diamante Seatpost**, paired with the sloping geometry for increased seatpost exposure, is engineered for optimal flex and compliance.

This combination enhances comfort on rough terrain and helps reduce fatigue during long rides. The seatpost features an updated saddle clamp and increased length of 380 mm.

This design accommodates a wider range of rider heights on a single frame size, making it easier to achieve an optimal fit.



Diamante Saddle Clamp

Designed for precision and ease, this clamp provides a secure and easily adjustable setup, allowing riders to find their perfect fit effortlessly.



ATTENTION TO EVERY DETAIL

Every component of the Palta has been meticulously engineered to enhance performance, reliability, and the overall riding experience:



UCI Approved frame

This approval guarantees that Palta is a high-performance racing frame, ready for any international event.

UDH Standard

Palta adopts the UDH standard, ensuring maximum compatibility with all modern drivetrains.



Microtech Solid Oil Bearings

These innovative headset bearings use solid oil lubrication, offering three times the durability of traditional bearings.

With extended lubricant life, resistance to washout, and superior protection against contaminants, they ensure smoother handling and long-lasting performance.



New Basso Ultra Torque Expander

Optimized for improved efficiency and easier maintenance, this expander system simplifies adjustments while ensuring reliability.

Weight: 34g

Ride, Perfected Thru Axles

Built for precision and durability, these thru axles provide stability and efficiency in every ride.

Weight: front 30g, rear 38g



5-Years Warranty

5-year warranty, available upon customer bike registration. Starting February 10, 2026, every carbon frame will be covered by this extended warranty, giving riders peace of mind with the assurance that Basso stands behind its commitment to quality and long-lasting performance.





DEDICATED FRAME BAGS



Developed alongside the design of the new Basso Palta, this collection of packs is designed to complement the bike's refined approach to race and adventure - streamlined, integrated, and built to perform without compromise.



- Integrated bolt-on attachment for a clean, seamless fit.
- Allows easy access to bottles and Palta's in-frame storage.
- Transparent side panels to find what is needed with ease.
- Waterproof materials and welded constructions using Apidura's proprietary Hexagrid Fabric, an ultralight, high-strength nylon grid, laminated with TPU.



TOP TUBE BAG
size: 0.4l
weight: 72g

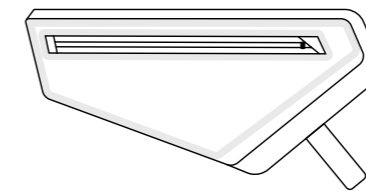

FRAME BAG SMALL
size: 1.4l
weight: 172g

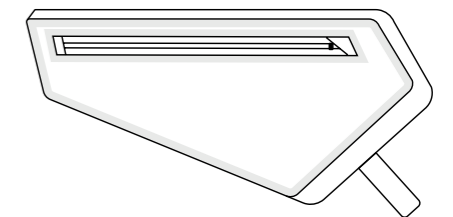

FRAME BAG LARGE
size: 2.0l
weight: 230g

DEDICATED DOWNTUBE "GUARD"

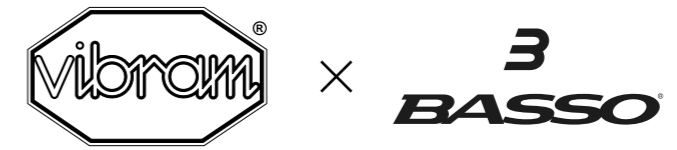

Two iconic Italian brands unite: Vibram and Basso collaborate on a unique cycling innovation. A specially designed protective sheet for the bicycle frame. Shields the down tube from impacts, scratches, and dirt.



- Features the signature "Diamante" texture.
- Proudly displays Vibram's famous yellow octagon, a mark of performance and durability.

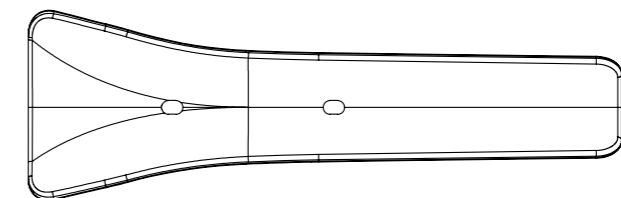

CONFIGURATIONS BIKE SPECS

Every bike is assembled on customer request.
Customer can choose everything.

GROUPSET	WHEELS	SEAT POST	COCKPIT OPTION	TIRES
Sram Red XPLR 1 × 13	Zipp 303 XPLR SW	-15 mm / 0 mm	Strato + Carbon Gravel / Fuga, / Levita	Pirelli Cinturato M 45 mm
Shimano GRX 825 2 × 12 DI2	Fulcrum SONIQ	-15 mm / 0 mm	Strato + Carbon Gravel / Fuga, / Levita	Continental Terra Trail 45 mm
Shimano GRX 825 2 × 12 DI2	Microtech MX25	-15 mm / 0 mm	Strato + Carbon Gravel / Fuga, / Levita	Continental Terra Trail 45 mm
Sram Force XPLR 1 × 13	Zipp 303 XPLR S	-15 mm / 0 mm	Strato + Carbon Gravel / Fuga, / Levita	Pirelli Cinturato M 45
Sram Force XPLR 1 × 13	Microtech MX25	-15 mm / 0 mm	Strato + Carbon Gravel / Fuga, / Levita	Continental Terra Trail 45 mm
Shimano GRX 2 × 12 820	Microtech Grecale	-15 mm / 0 mm	Strato + Carbon Gravel	Continental Terra Trail 45 mm
Shimano GRX 2 × 12 820	Microtech MX25	-15 mm / 0 mm	Strato + Carbon Gravel	Continental Terra Trail 45 mm
Shimano GRX 1 × 12 820	Microtech Grecale	-15 mm / 0 mm	Strato + Carbon Gravel	Continental Terra Trail 45 mm
Shimano GRX 1 × 12 820	Microtech MX25	-15 mm / 0 mm	Strato + Carbon Gravel	Continental Terra Trail 45 mm

MICROTECH GRECALE



TECHNICAL SPECS

Wheelset Weight: 1680 g
Front Wheel Weight: 775 g
Rear Wheel Weight: 905 g

Rim Material: Carbon UDshaped™ / Tubeless Ready with Mini-Hook
Internal Rim Width: 23 mm
Rim Width: 30 mm
Profile Height: 50 mm

Hub: U-RD.30 / Front 100x12 mm, Rear 142x12 mm / 3 pawls
Bearings: High-rolling efficiency
Brake Compatibility: Center Lock Disc

Spokes: Sapim Leader / 24 – 1:1
Nipples: Alpina Brass

MICROTECH MX25



TECHNICAL SPECS

Wheelset Weight: 1990 g
Front Wheel Weight: 920 g
Rear Wheel Weight: 1070 g

Rim Material: Alloy / Tubeless Ready with Mini-Hook
Internal Rim Width: 25 mm
Rim Width: 28 mm
Profile Height: 25 mm

Hub: U-RD.20 / Front 100x12 mm, Rear 142x12 mm / 3 pawls
Bearings: High-rolling efficiency
Brake Compatibility: Center Lock Disc

Spokes: Sapim Leader / 24 – 1:1
Nipples: Alpina Brass

DEDICATED APPAREL



PALTA III

B
BASSO[®]

bassobikes.com