

LytW8 Down Pullover Instructions

LytW8.com

© Jamie Shortt, 2012



Notes

- This jacket was originally created using modified Kinsman pullover from Thru-hiker.com. I recommend buying a kinsman kit and completing the synthetic version first. You will learn a lot. You can purchase additional materials thru-hiker and complete a down version.
- The instructions assumes you have significant sewing skills and are just looking for basic steps for how to turn an existing pullover pattern into a down garment.
- For materials I used M50 breathable nylon for outer and liner; 900 fill power down; and 13" #3YYK zipper and standard gutermann thread.
- For down I recommend using ~2.5-4 oz of down across the entire jacket (Men's medium) depending on fill power and desired loft. Loft targets should be 1" to 1.5".

Length	Width	Area (Length X Width)	Target Loft	Volume (Area X Loft)	Down Fill Power (cu. In. per oz)	Oz of Down (Fill Power / Volume)	Grams of Down (Oz. X 28.35)
28	2.75	77	1.5	115.5	800	0.1444	4.1

- The user needs to calculate the area of each chamber using a loft target (e.g. 1.5") and down fill power rating to determine the grams of down to stuff into a chamber. For example a chamber that is 28" long and 2.75" with a target loft of 1.5" would require 4.1 grams of down.

Down Pullover Pieces

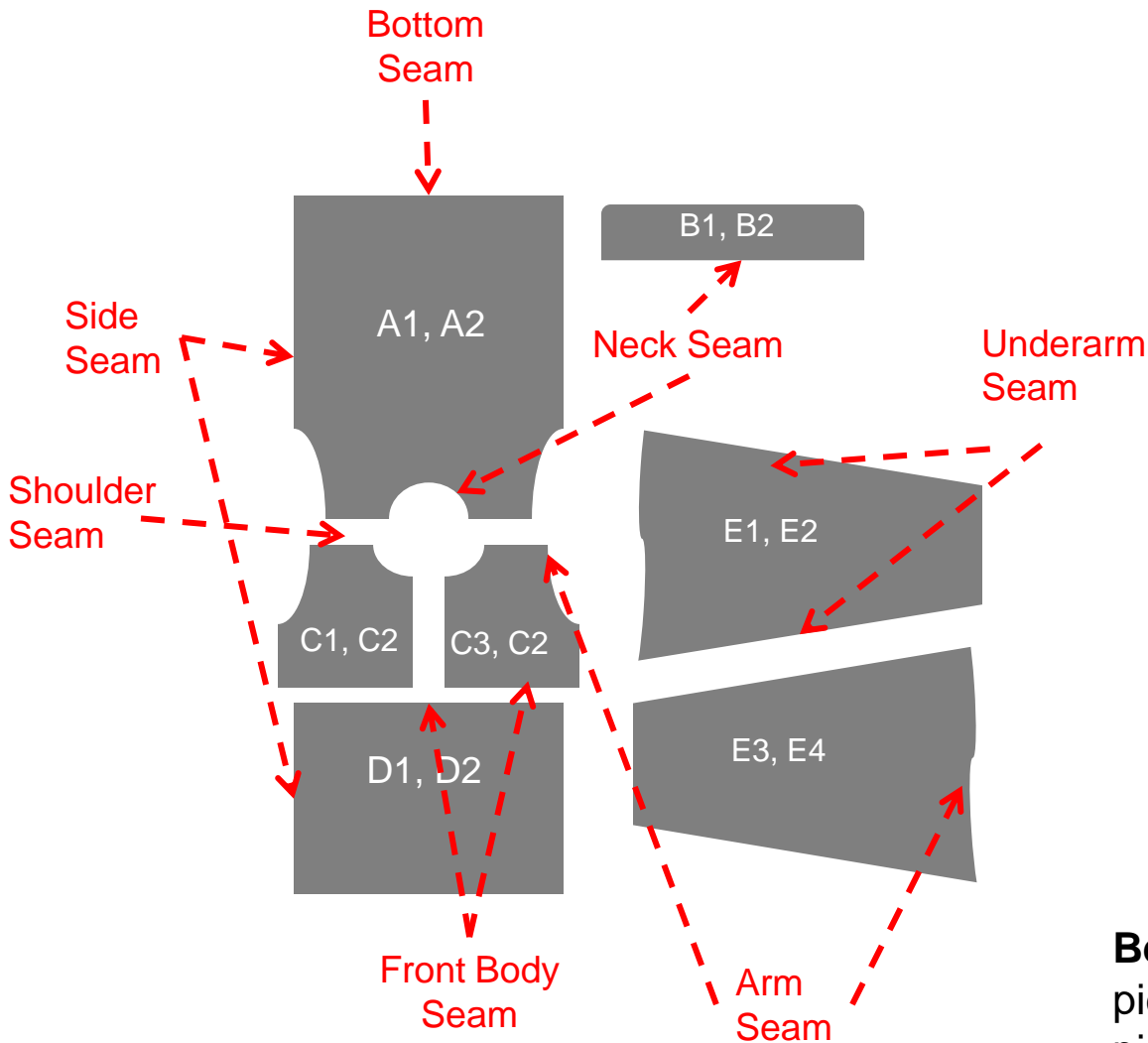

Materials

- M50 material
- 2.5-4 oz of 800+ fp down
- Thread
- Elastic for cuffs
- YKK #3 separating zipper, single pull slider, and stops

Pieces

A1, A2 Back
C1, C2, C3, C4 Top Fronts
D1, D2 Front Bottoms
E1, E2, E3, E4 Sleeves
B1, B2 Collar

Acronyms

WST – Wrong sides together
RST – Right sides together

Begin by cutting out the above pieces according. Two of each piece with the material wrong side together (WST).

Instructions - body

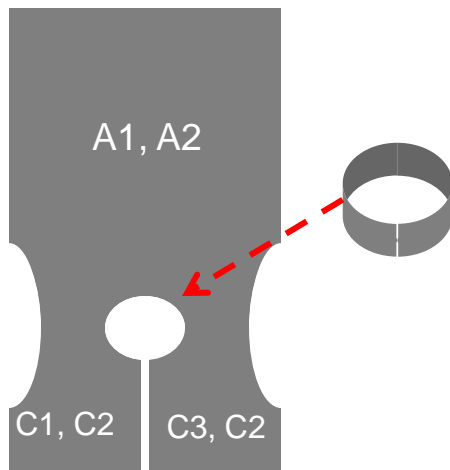

1. Sew A1 to C1 and C3 at shoulder seam RST
2. Sew A2 to C2 and C4 at shoulder seam RST
3. Sew collar piece B1 to A1C1C3 at neck seam RST
4. Sew collar piece B2 to A2C2C4 at neck seam RST
5. Put 2 new pieces together from step 3 and 4 pinning zipper halves in place in between. The fabric should be RST. Continue pinning across the collar top.

Instructions – body continued

6. Sew up one side of the zipper across the top of the collar and down the other side. Flip back WST and sew a second seam up one side, across collar top, and down other side, approximately ¼” allowance.
7. Install zipper slider and zipper stops at top of zipper.
8. Pin the front bottoms pieces (D1, D2) to rest of body RST. Sew one seam across all four pieces and the bottom of the zipper.
9. Sew the collar closed on the inside leaving a 2” gap. Stuff the collar with down and sew the gap closed.
10. With the bottom front pieces WST tuck the remaining body up in between. Pin the bottom of the front together. Sew a seam along the bottom edge of D1 & D2.
11. Turn the bottom edge inside out. Now repeat step 9 for them bottom edge of the back (A1, A2).

Instructions – Stuffing the body

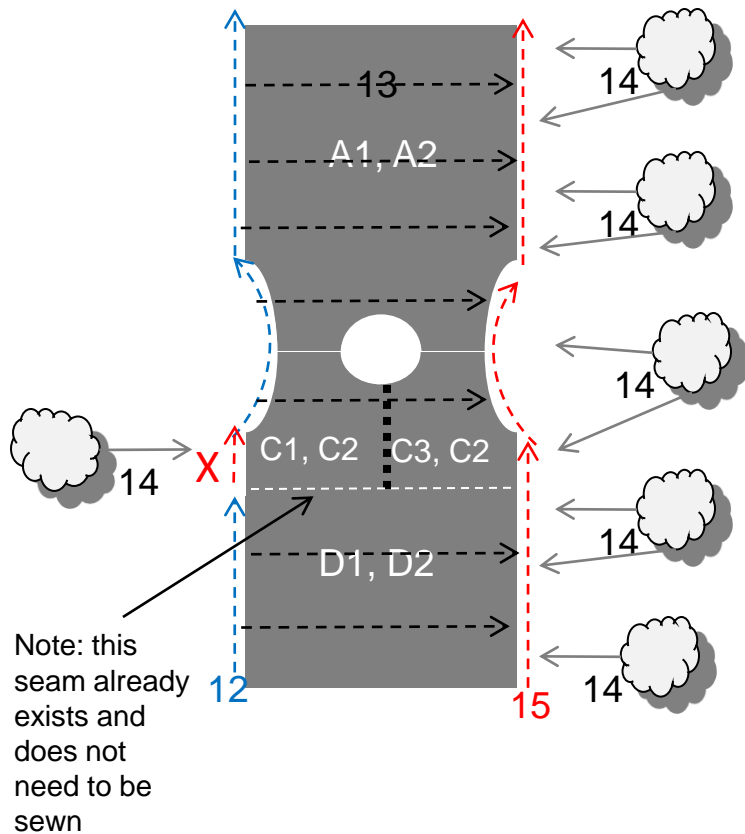

12. Turn the back right sides out. Sew the left side of the front body, arm hole, and left back, (blue arrows), skipping a 2" section of the top front (C1,C2).
13. Sew the horizontal baffles 2.5" apart. (black arrows)
14. Stuff down into each of the horizontal baffles. Note use the skipped section from step 11 to stuff the front top left section.
15. Sew the right side of the body closed and the top left section. (red arrows)
16. Optional Step – if down stuffing is under and inch loft it is recommend that vertical baffles be sewn to stabilize down. These should be sewn to form approximate squares.

Sleeves- Elastic Cuffs

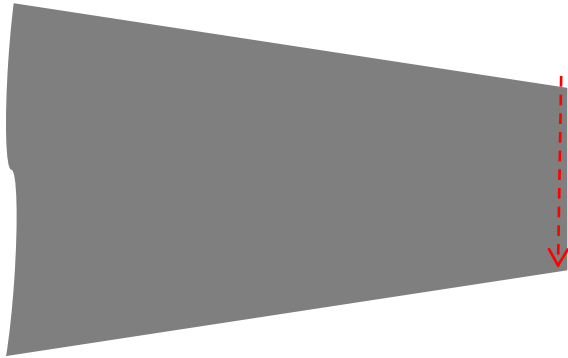

17. Sew sleeves together at wrist WST.
18. Cut elastic two pieces the length of your wrist.
19. Turn the sleeves RST and sew a chamber to match the width of your elastic.
20. Slide elastic into the chamber and sew in place at the ends leaving $\frac{3}{4}$ " from the side seam. Use a zig zag stitch.

1/8" wide zip zag stitch

Note elastic is actually inside the chamber

Sew 3/4" from edge of seam

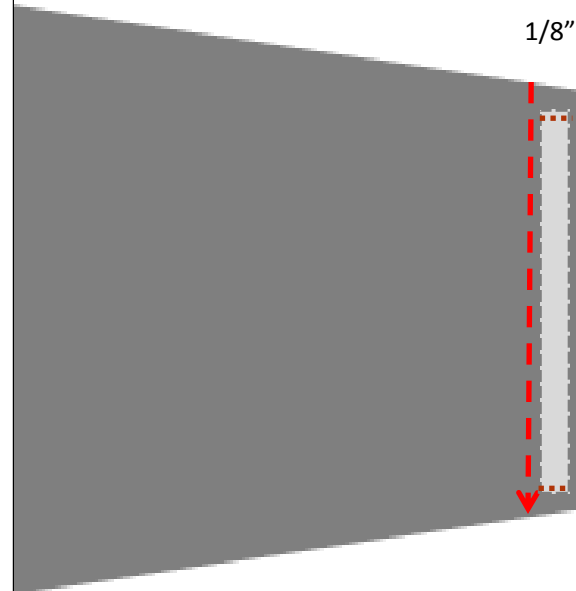

Instructions - Arms

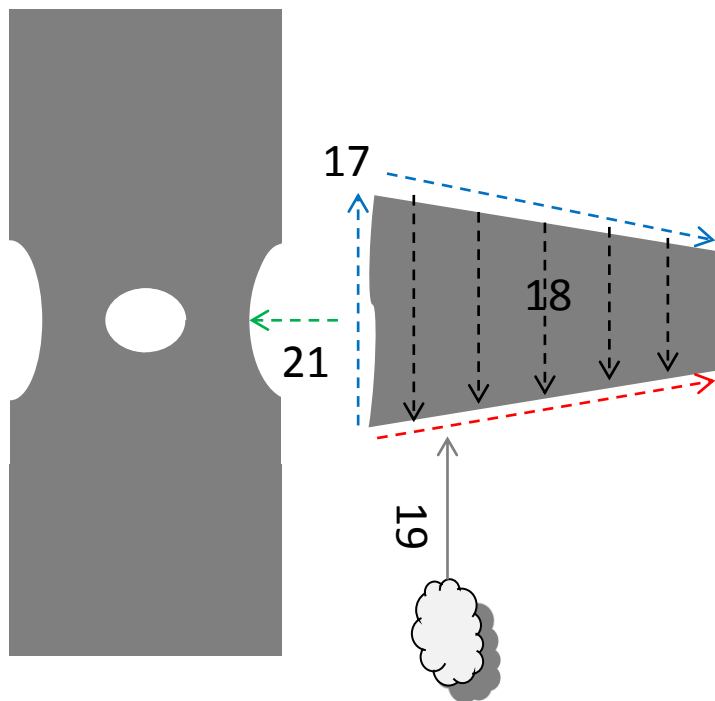

21. Sew right arms pieces together (E1, E2) WRT along the arm seam, across one of the underarm seams, and down the wrist seam. (blue lines)
22. Sew the horizontal baffles 2.5" apart. (black lines)
23. Stuff the down into the chambers.
24. Sew the remaining underarm seams closing the down chambers. (red line)
25. Repeat steps 16 to 19 for the other arm.
26. Sew the arms to the body with a French seam.
27. Optional – sew vertical baffles for lightly stuffed jackets to stabilize the down. This will make a square quilt pattern instead of long horizontal pattern.

Instructions – Finishing the Jacket with French Seam

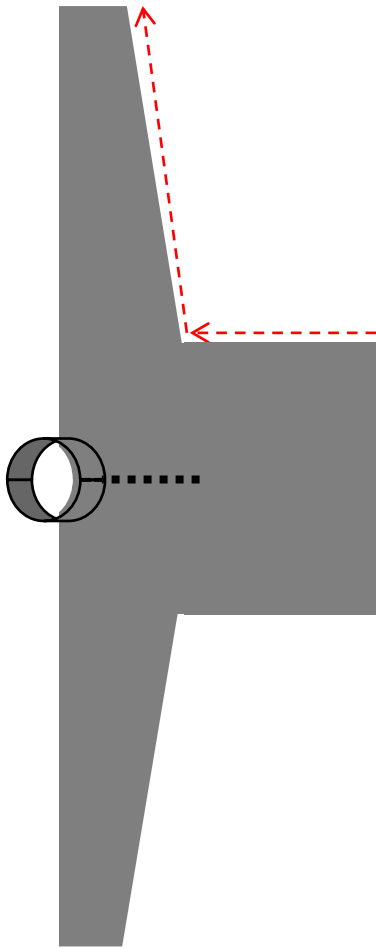

28. With WST (right sides out) sew a $\frac{1}{4}$ " seam (red lines).
29. Trim the seam to $\frac{1}{8}$ ". Be careful not to cut into jacket. Take your time with this step.
30. Turn the jacket RST (inside out) and sew the edge seam a second time (red lines) with $\frac{1}{4}$ " seam. This will hide the raw edges.
31. Repeat step 24-26 for the other side.

Congratulations your jacket is finished.