

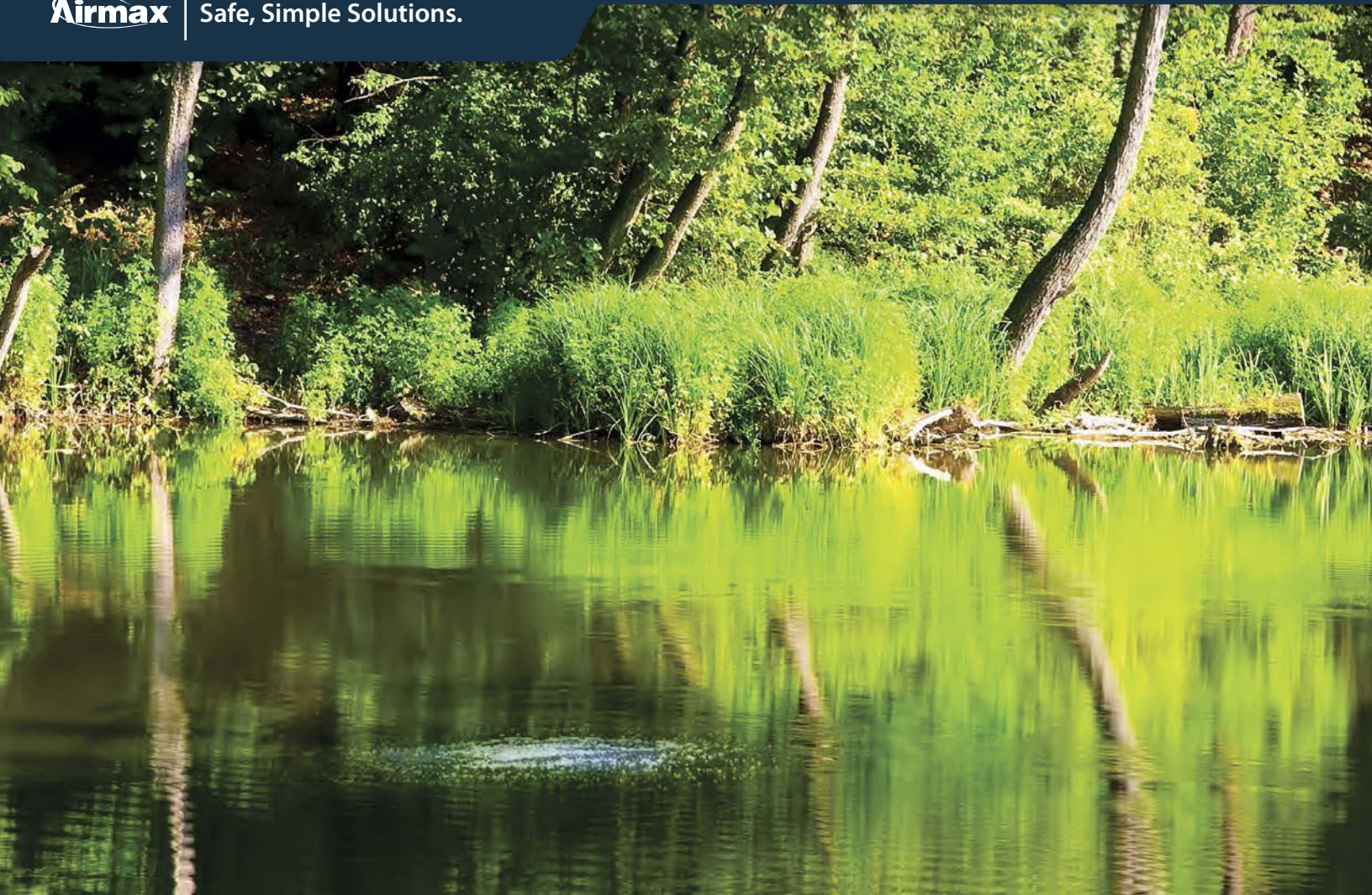

**Airmax**<sup>®</sup>

# **2020** CATALOG

The Clear Choice for Ponds and Lakes



## TABLE OF CONTENTS

### Aeration & Fountains

- Aeration - Pond & Lake .....4- 15
  - Shallow Water Series .....8-9
  - PondSeries..... 10 - 11
  - LakeSeries..... 12
  - Parts & Accessories ..... 13- 15
- EcoSeries Fountain..... 16 - 19
- Fountain Light Sets ..... 20- 21

### Pond & Lake Treatments

- Algae & Weed Control ..... 29- 31
- Pond Cleaners..... 26- 27
- Pond Dye .....24
- Water Clarifiers .....22- 25

# Airmax<sup>®</sup>

## Pond & Lake Solutions

Airmax products are a result of over a decade of research and real world testing. Airmax was developed exclusively for ponds and lakes and has become the most recognized brand among pond and lake owners with a reputation for a natural simplified approach to pond management.

**Looking for Water Garden Products?  
Visit [Crystalclearpond.com](http://Crystalclearpond.com)**



# The Airmax Ecosystem™

## Pond & Lake Solutions Guide

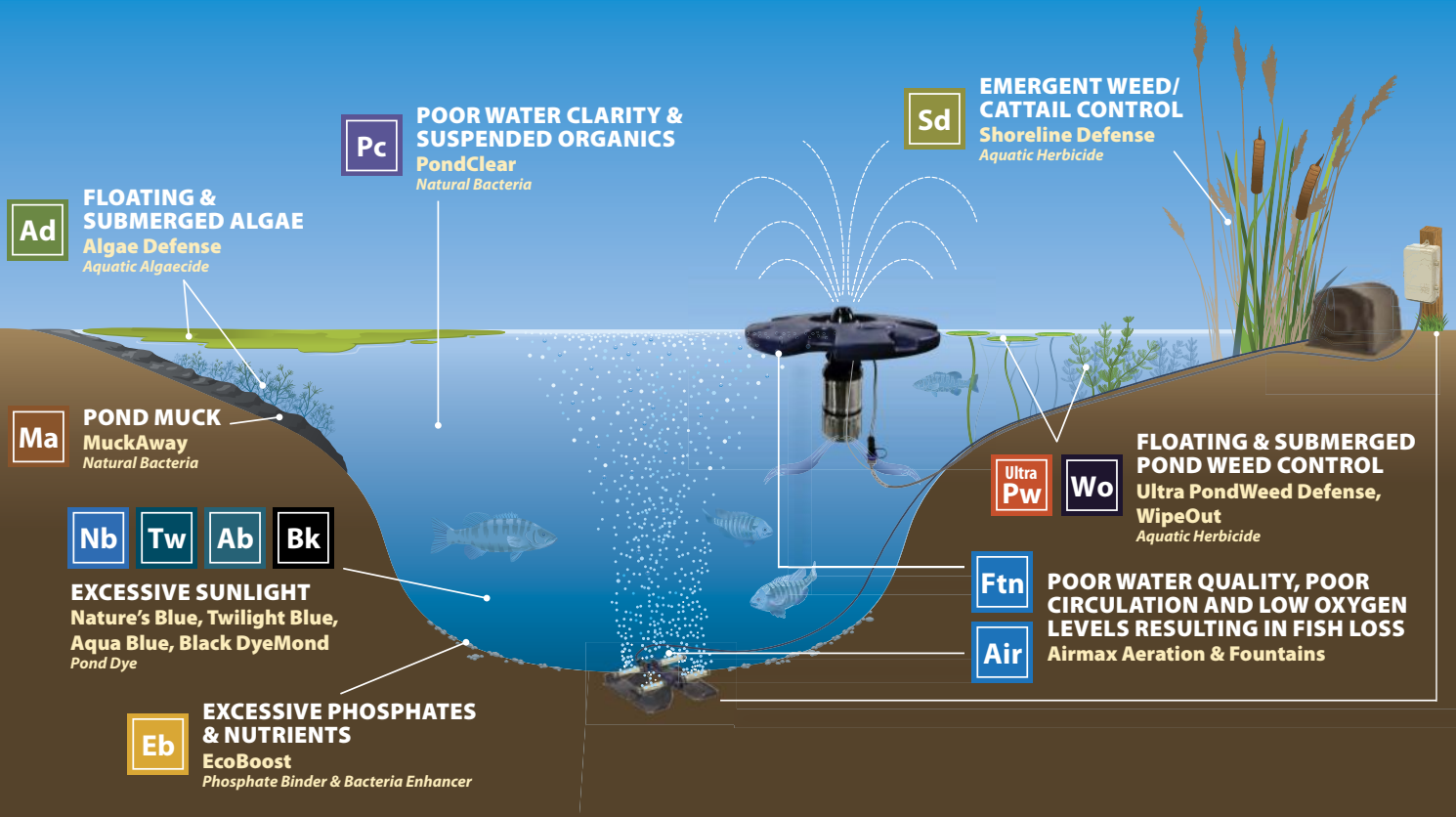

## PROACTIVE VS. REACTIVE POND MANAGEMENT

Up until the last few years, most pond owners have relied on REACTIVE pond management practices to keep their ponds clear of excessive, unwanted, aquatic growth. They've traditionally waited for the problem to appear then treated it chemically. Although sometimes necessary as a management tool, chemical applications can be bandages for the real problem and can actually contribute to the problem by adding more nutrient rich muck and increasing the overall nutrient load.

Since the introduction of the Airmax Ecosystem program, pond owners have been able to convert to, and rely on, PROACTIVE pond management practices. Using aeration, 100% natural bacteria and/or pond dyes, they've been able to get directly at the SOURCE of their problems; excessive nutrients in the water column and muck at the bottom of the pond. By providing microbial competition for these nutrients, they've successfully maintained healthy, clear ponds.

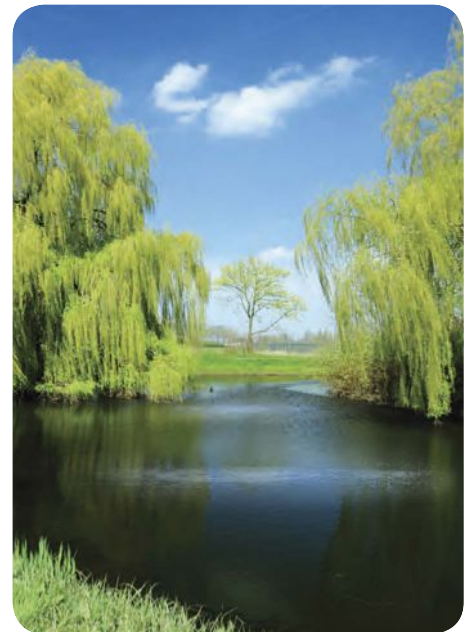



**The World's Best Aerator**

- Most Effective
- Quietest
- Most Efficient
- Easiest to Install
- Made in the USA

# Improve water clarity and reduce muck in just 90 days!

## The Proof is in the Science

An independent study with Airmax Aeration

**The Pond:** A ½ acre, kidney shaped, 10+ year old pond located in the state of North Carolina. The pond had nearly 12" of muck buildup and required monthly chemical treatments to reduce algae blooms.

**The Plan:** Before the Airmax Aeration System was introduced; water samples were taken for phosphorus, nitrogen, biochemical oxygen demand (BOD), dissolved oxygen and water clarity. Phosphorus and nitrogen are contributors to algae growth while dissolved oxygen and BOD help determine the potential for muck and nutrient reducing aerobic bacteria. A PS20 Airmax Aeration System was installed and water samples were taken every 30 days. The results speak for themselves.

**The Results in 90 Days:** Nitrogen & Phosphorus plummeted 90%. Oxygen became saturated throughout the pond and the water clarity dramatically improved. There was also a major reduction in the amount of algae that needed to be treated. The BOD also decreased substantially while the aerobic bacterial activity increased which was responsible for almost ¼" of muck reduction in only 90 days.

### Improved Water Clarity through Nutrient Reduction

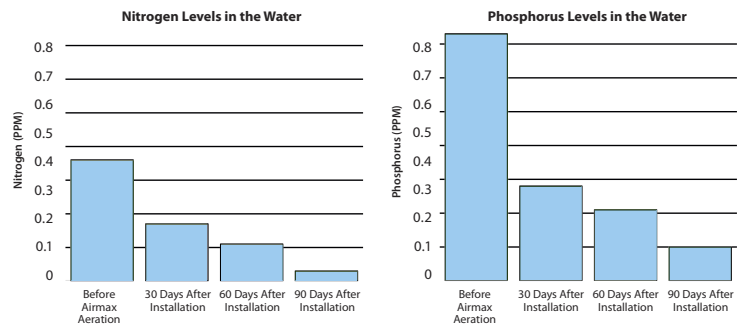

### Reduced Muck & Healthier Fish through Oxygen Saturation

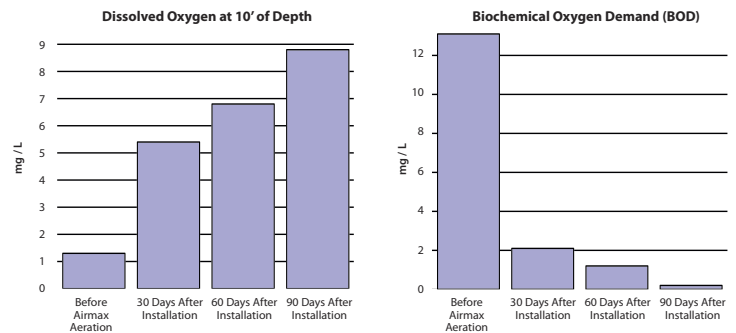

### Results You Can See in 90 Days



\* Independent study by Aeration Technologies of North Carolina.





# Airmax® Assist™ Results Guaranteed!

## Aeration Mapping Service The right system for the perfect pond!

Let Airmax Design the Right System for Your Pond! Selecting the right system as well as determining the proper placement of the diffusers is vital to ensuring you are circulating and aerating your pond or lake effectively. Having incorrectly placed diffusers or under-sizing an aeration system limits the overall effectiveness of an aeration system. Our Aeration Mapping Service ends the guesswork. Let an Airmax professional layout the perfect system for your pond and we will guarantee the results!

### Here is How to Get Your Layout:

Log on to [airmaxeco.com/airmax-assist](http://airmaxeco.com/airmax-assist) and fill out the online form with all of your pond information. Upon receipt, one of our professionals will get to work to map, measure and properly design an Airmax Aeration System. You will then receive an aeration system layout with diffuser locations and complete system specifications branded with your company logo.

**Please note:** Airmax utilizes satellite maps provided by Google and/or Bing for all mapping requests. We may be limited by photo data if no recent satellite image was taken.

**Customer Information**

Customer Number	706532	Site Address	123 Main St.
Customer Name	John Smith	Date Created	04/02/2018
Site Name	John's Pond	Design Tech	Scott Finn

**Recommended Airmax® Aeration System(s)**

**Airmax® PondSeries™ PS20 Aeration System**

**Customer Information**

Customer Number	706532	Site Address	123 Main St.
Customer Name	John Smith	Date Created	04/02/2018
Site Name	John's Pond	Design Tech	Scott Finn

**John Smith Pond**  
Option 2 based on 15' deepest

**Legend**

- 3/8" Weighted Airline
- Profil-4 Diffusers
- PS20 System

**Weighted Airline Size (inch)**

3/8	70
3/8	135

**Weighted Airline 5/8 inch**

75	135
----	-----

**Pond Information**

System Specifications		Results for Aeration	
Surface Acres:	.33	Total Volume (gallons):	500,000
Average Depth:	7	Calculated Site Turnovers / 24hrs:	20.02
Acre Feet:	2.31	Estimated System PSI:	159
Deepest Diffuser Depth (feet):	15		
Perimeter (feet):	490		

**Software: 2 of 3**

**1 of 3**

This system was calculated, designed and verified using AirmaxAssist™ Software. To learn more about Airmax® Aeration Systems, please visit [airmaxeco.com](http://airmaxeco.com).



## Shallow Water Series™

### System Features:

- Perfect for shallow ponds or beach areas up to 10' deep
  - Single systems can aerate up to 1/2 acre
  - ETL Electrical Safety Certification
  - Extremely efficient, costs as little as \$3.48/month to run 24/7
  - Available in 115V or 230V\*
- \* Shallow Water HP Series Only.



## PondSeries™

### System Features:

- Perfect for ponds or small lakes up to 21' deep
- Single systems can aerate up to 8 acres
- ETL Electrical Safety Certification
- Extremely efficient compressor costs as little as \$9.27/month to run 24/7
- Available in 115V or 230V



## LakeSeries™ High Volume

### System Features:

- Highest CFM rating per diffuser
- Perfect for larger ponds or lakes up to 50' deep
- Single systems can aerate up to 6+ acres
- Extremely efficient compressor costs as little as \$47.53/month to run 24/7
- ETL Electrical Safety Certification
- Available in 115V or 230V



## Airmax® Warranty Information

- Cabinet - Lifetime
- Airline & Diffusers - 5 Years
- Compressor - 2 Years



## Why pond depth matters

The deeper a diffuser plate is placed in your pond, the more area it can effectively aerate. Shallow ponds, or ponds with irregular shapes & bends, require more diffuser plates per surface acre.

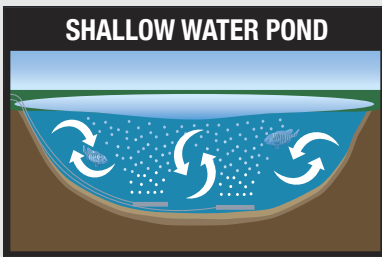

In shallow ponds, the column of diffused air is not able to "open" as far which limits the effective area of each plate. The bends and curves in irregular shaped ponds block the circulation provided by an aeration system which creates the need for more plates to reach isolated sections of your pond.

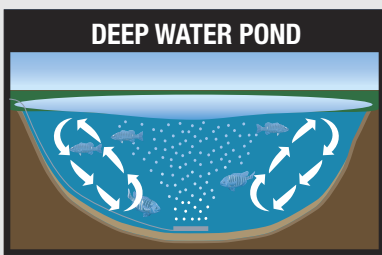

As diffused air leaves the diffuser plate, it rises to the pond's surface in a V pattern, creating a current. The higher this pattern is able to rise, the wider it becomes which allows it to circulate a greater volume of water.



# The Airmax® Advantage

## SilentAir™ Compressors

Most Efficient & Long Lasting  
2-Year Warranty  
Made in the USA

- A. Large Air Filter – Maximizes the life of compressor
- B. High Efficiency SilentAir Compressor
- C. Braided Hose Sleeve – Protects internal airlines from wear
- D. Manifold w/ Nickel Plated Ball Valves – Simplifies airflow management
- E. Rubber Compressor Mounts – Reduces noise and vibration for silent operation
- F. Airline Quick Disconnects – For easy system removal and storage

### LR Series Linear Diaphragm



### RP Rocking Piston Series

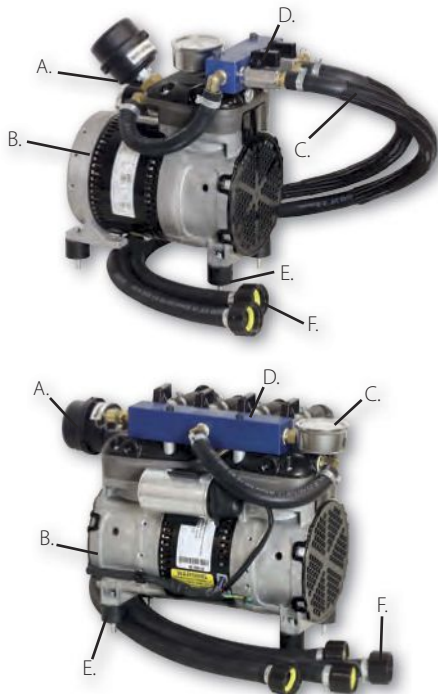

## ProAir™ Weighted Diffusers

Maximum Circulation & Low Maintenance  
5-Year Warranty  
Made in the USA

- A. PTFE Non-Stick 6" Membrane Diffuser Stick – Provides the synergies of air stones while being virtually maintenance-free
- B. Check Valve – Prevents back pressure on compressor

- C. Innovative Sled Design – Keeps diffuser submerged while maintaining an upright position during installation

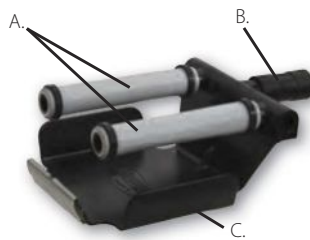

**ProAir 2 For Shallow Water Ponds**  
Diffuser Size: 14.75"L x 8"W x 3.75"H

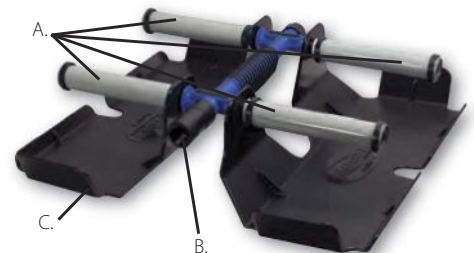

**ProAir 4 For Ponds And Lakes**  
Diffuser Size: 19"L x 19"W x 5"H

## Airmax Composite Cabinet

Quietest Design & Easy to Install  
Lifetime Warranty On Cabinet  
2-Year Warranty On Electrical Components

- A. Composite Cabinet w/ Removable Top – Protects components while providing easy access
- B. Ventilation Fan w/ Rain Shroud – Cools and protects against moisture and heat damage
- C. Pre-wired Electrical Box – Simplifies electrical connections for easy setup

- D. Elevated Base – Protects against damaging flood water
- E. High Density Air Intake Filter – Protects the compressor from outside contaminants



**Standard Cabinet**  
Cabinet Size: 23"L x 17"W x 15"H



**Large Cabinet**  
Cabinet Size: 27"L x 24"W x 18.75"H

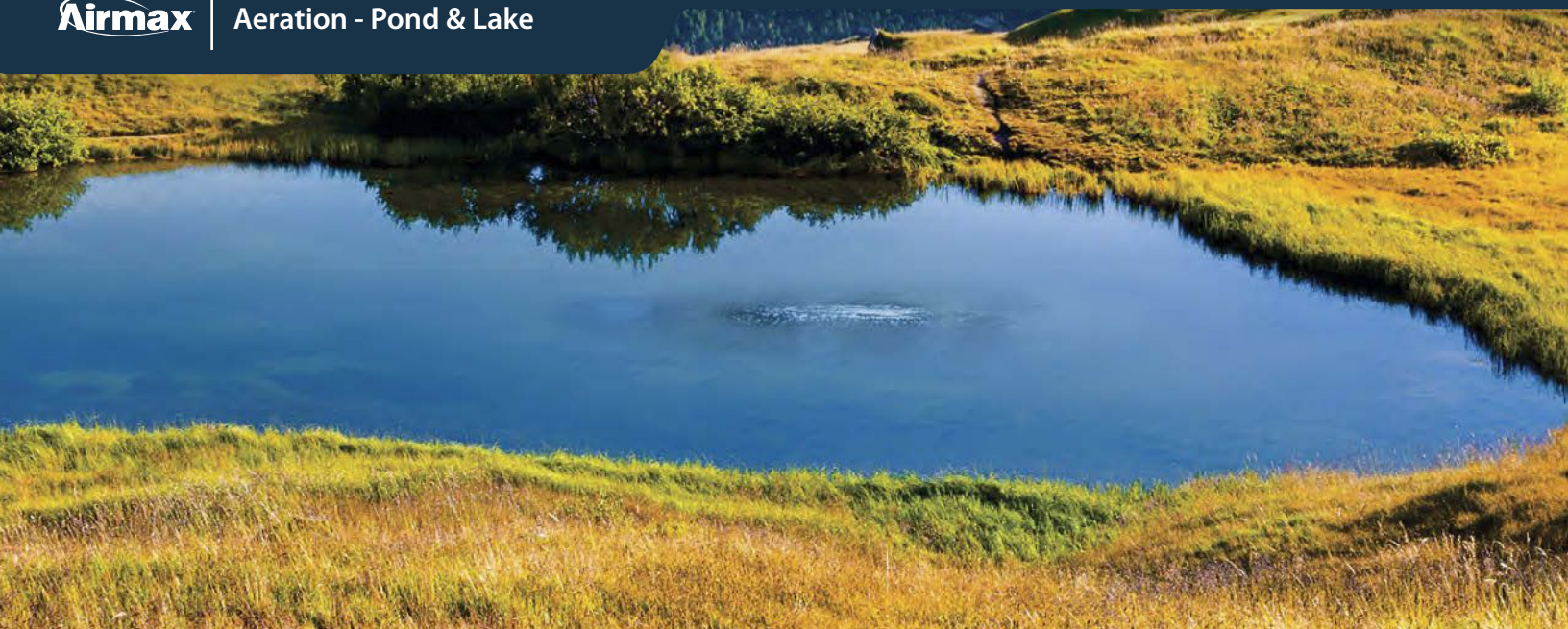

## Shallow Water Series™ Max Depth 6'



### SW20 • Aerates Ponds up to 1/4 Acre, 6' Deep

#### SW20 System Specs:

Running Amps .....	0.6
Volts .....	115
Max CFM .....	2.5
Max Depth .....	6'
Op. Cost / Mo.* .....	\$3.48 (24/7)

- #600801 - SW20, w/o Airline, Use 5/8" Airline Only
- #600803 - SW20, 200' 3/8" EasySet Weighted Airline

#### SW20 Includes:

- (2) ProAir 2 Weighted Diffusers
- Standard Airmax Composite Cabinet
- High Efficiency LR25 SilentAir Linear Diaphragm Compressor



### SW40 • Aerates Ponds up to 1/2 Acre, 6' Deep

#### SW40 System Specs:

Running Amps .....	1.1
Volts .....	115
Max CFM .....	4.9
Max Depth .....	6'
Op. Cost / Mo.* .....	\$6.38 (24/7)

- #600811 - SW40, w/o Airline, Use 5/8" Airline Only
- #600813 - SW40, 400' 3/8" EasySet Weighted Airline

#### SW40 Includes:

- (4) ProAir 2 Weighted Diffusers
- Standard Airmax Composite Cabinet
- High Efficiency LR50 SilentAir Linear Diaphragm Compressor



\*Cost per month is calculated at 7¢ per kilowatt hour. Cost will vary depending on location.





# Airmax® Aeration is easy to install

Airmax systems can be installed at the pond's edge or up to ¼ mile away from your pond.

### You Have Options with Airmax

Airmax Aeration Systems are the easiest and most versatile systems to install on the market. Airmax Aeration Systems can be installed next to the pond's edge or as far as ¼ mile away! No power is needed at shore! Airmax utilizes their EasySet Direct Burial Airline to deliver oxygen to your pond without the added expense of hiring an electrician.

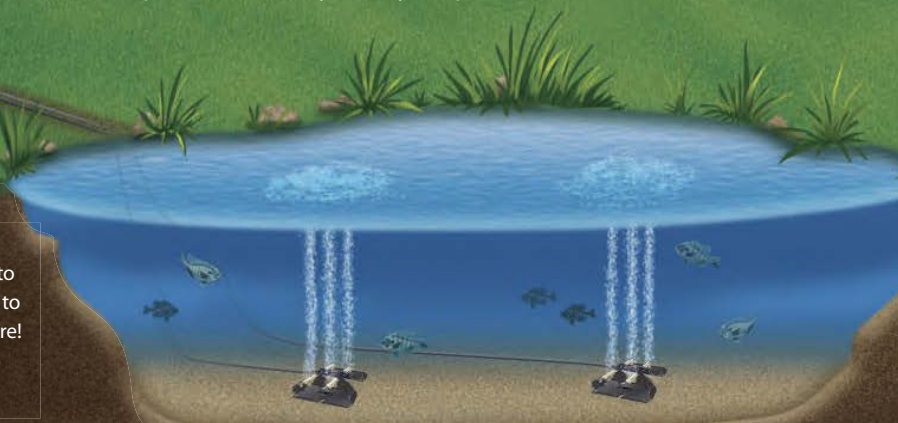

## Shallow Water HP Series™ High Pressure, Max Depth 10'



### SW20HP • Aerates Ponds up to 1/4 Acre, 10' Deep

#### SW20HP System Specs:

Running Amps .....	1.6 or 0.8
Volts .....	115 or 230
Max CFM .....	2.3
Max Depth .....	10'
Op. Cost / Mo.* .....	\$9.27 (24/7)

- #600804 - SW20HP, w/o Airline, Use 5/8" Airline Only, 115V
- #600805 - SW20HP, w/o Airline, Use 5/8" Airline Only, 230V

#### SW20HP Includes:

- (2) ProAir 2 Weighted Diffusers
- Standard Airmax Composite Cabinet
- RP25 1/4 HP SilentAir Rocking Piston Compressor

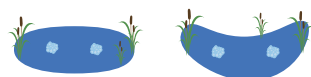

### SW40HP • Aerates Ponds up to 1/2 Acre, 10' Deep

#### SW40HP System Specs:

Running Amps .....	4.1 or 2.1
Volts .....	115 or 230
Max CFM .....	4.7
Max Depth .....	10'
Op. Cost / Mo.* .....	\$23.76 (24/7)

- #600814 - SW40HP, w/o Airline, Use 5/8" Airline Only, 115V
- #600815 - SW40HP, w/o Airline, Use 5/8" Airline Only, 230V

#### SW40HP Includes:

- (4) ProAir 2 Weighted Diffusers
- Standard Airmax Composite Cabinet
- RP50 1/2 HP SilentAir Rocking Piston Compressor

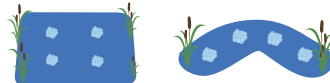

\*Cost per month is calculated at 7¢ per kilowatt hour. Cost will vary depending on location.



## PondSeries™ Systems For Ponds Up To 8 Acres



### PS10 • Aerates Ponds up to 1 Acre

#### PS10 System Specs:

Running Amps .....	1.6 or 0.8
Volts .....	115 or 230
Max CFM .....	2.3
Max Depth .....	21' **
Op. Cost / Mo.* .....	\$9.27 (24/7)

- #600821 - PS10, w/o Airline, Use 5/8" Airline Only, 115V
- #600822 - PS10, 100' 3/8" Airline, 115V
- #600824 - PS10, w/o Airline, Use 5/8" Airline Only, 230V
- #600825 - PS10, 100' 3/8" Airline, 230V

#### PS10 Includes:

- (1) ProAir 4 Weighted Diffuser
- Standard Airmax Composite Cabinet
- RP25 1/4 HP SilentAir Rocking Piston Compressor

#### Provides Aeration For:

- Up to 1/4 Acre** ..... 6'- 9' deep
- Up to 1/2 Acre** ..... 9'-12' deep
- Up to 1 Acre** ..... 12'-21' deep

### PS20 • Aerates Ponds up to 2 Acres

#### PS20 System Specs:

Running Amps .....	4.1 or 2.1
Volts .....	115 or 230
Max CFM .....	4.7
Max Depth .....	21' **
Op. Cost / Mo.* .....	\$23.76 (24/7)

- #600831 - PS20, w/o Airline, Use 5/8" Airline Only, 115V
- #600832 - PS20, 200' 3/8" Airline, 115V
- #600834 - PS20, w/o Airline, Use 5/8" Airline Only, 230V
- #600835 - PS20, 200' 3/8" Airline, 230V

#### PS20 Includes:

- (2) ProAir 4 Weighted Diffusers
- Standard Airmax Composite Cabinet
- RP50 1/2 HP SilentAir Rocking Piston Compressor

#### Provides Aeration For:

- Up to 1/2 Acre** ..... 6'- 9' deep
- Up to 1 Acre** ..... 9'-12' deep
- Up to 2 Acres** ..... 12'-21' deep



### PS30 • Aerates Ponds up to 3 Acres

#### PS30 System Specs:

Running Amps .....	4.1 or 2.1
Volts .....	115 or 230
Max CFM .....	4.7
Max Depth .....	21' **
Op. Cost / Mo.* .....	\$23.76 (24/7)

- #600841 - PS30, w/o Airline, Use 5/8" Airline Only, 115V
- #600842 - PS30, 300' 3/8" Weighted Airline, 115V
- #600845 - PS30, w/o Airline, Use 5/8" Airline Only, 230V
- #600846 - PS30, 300' 3/8" Weighted Airline, 230V

#### PS30 Includes:

- (3) ProAir 4 Weighted Diffusers
- Standard Airmax Composite Cabinet
- RP50 1/2 HP SilentAir Rocking Piston Compressor

#### Provides Aeration For:

- Up to 1 1/2 Acres** .. 6'- 9' deep
- Up to 2 Acres** ..... 9'-12' deep
- Up to 3 Acres** ..... 12'-21' deep

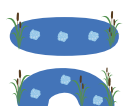

\* Cost per month is calculated at 7c per kilowatt hour. Cost will vary depending on location. \*\* For operation greater than 21' deep, use Deep Water Kit, pg 13.





**PondSeries™** Systems For Ponds Up To 8 Acres

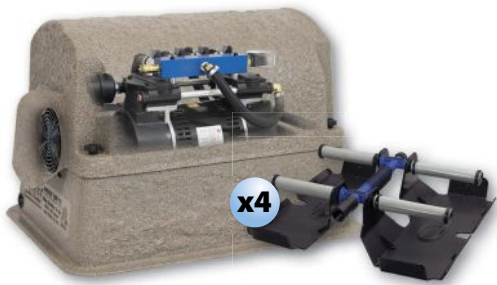

**PS40 • Aerates Ponds up to 4 Acres**

**PS40 System Specs:**

Running Amps .....	5.3 or 2.7
Volts .....	115 or 230
Max CFM .....	5.8
Max Depth .....	21' **
Op. Cost / Mo.* .....	\$.30.72 (24/7)

- #600851 - PS40, w/o Airline, Use 5/8" Airline Only, 115V
- #600855 - PS40, 400' 3/8" Weighted Airline, 115V
- #600857 - PS40, w/o Airline, Use 5/8" Airline Only, 230V
- #600858 - PS40, 400' 3/8" Weighted Airline, 230V

**PS40 Includes:**

- (4) ProAir 4 Weighted Diffusers
- Standard Airmax Composite Cabinet
- RP75 3/4 HP SilentAir Rocking Piston Compressor

**Provides Aeration For:**

- Up to 2 Acres** ..... 6'- 9' deep
- Up to 3 Acres** ..... 9'-12' deep
- Up to 4 Acres** ..... 12'-21' deep



**PS80 • Aerates Ponds up to 8 Acres**

**PS80 System Specs:**

Running Amps .....	10.6 or 5.3
Volts .....	115 or 230
Max CFM .....	11.6
Max Depth .....	21' **
Op. Cost / Mo.* .....	\$.61.44 (24/7)

- #600948 - PS80, w/o Airline, Use 5/8" Airline Only, 115V
- #600949 - PS80, w/o Airline, Use 5/8" Airline Only, 230V

**PS80 Includes:**

- (8) ProAir 4 Weighted Diffusers
- Large Airmax Composite Cabinet
- (2) RP75 ¾ HP SilentAir Rocking Piston Compressor

**Provides Aeration For:**

- Up to 4 Acres** ..... 6'- 9' deep
- Up to 6 Acres** ..... 9'-12' deep
- Up to 8 Acres** ..... 12'-21' deep

\* Cost per month is calculated at 7¢ per kilowatt hour. Cost will vary depending on location. \*\* For operation greater than 21' deep, use Deep Water Kit, pg 13



**LakeSeries™** Systems For Ponds Up to 6+ Acres



**LS40 • Aerates Ponds up to 5 Acres**

**LS40 System Specs:**

Max/Running Amps.....	8.2 or 4.1
Volts.....	115 or 230
Max CFM .....	9.4
Max Depth .....	50'
Op. Cost / Mo.* .....	\$47.53 (24/7)

- #600931 - LS40, No Airline, 115V
- #600933 - LS40, No Airline, 230V

**LS40 Includes:**

- (4) ProAir 4 Weighted Diffusers
- Large Airmax Composite Cabinet w/ Junction Box
- Two RP50 ½ HP SilentAir Rocking Piston Compressors
- Airline Sold Separately - Set Up for 5/8" Airline Only

**Provides Aeration For:**

<b>Up to 2 1/2 Acres</b> .....	6'- 9' deep
<b>Up to 3 1/2 Acres</b> .....	9'-12' deep
<b>Up to 5 Acres</b> .....	12'-50' deep



**LS60 • Aerates Ponds up to 6 Acres**

**LS60 System Specs:**

Max/Running Amps.....	10.6 or 5.3
Volts.....	115 or 230
Max CFM .....	11.6
Max Depth .....	.50'
Op. Cost / Mo.* .....	\$61.44 (24/7)

- #600941 - LS60, No Airline, 115V
- #600943 - LS60, No Airline, 230V

**LS60 Includes**

- (6) ProAir 4 Weighted Diffusers
- Large Airmax Composite Cabinet w/ Junction Box
- Two RP75 3/4 HP SilentAir Rocking Piston Compressors
- Airline Sold Separately - Set Up for 5/8" Airline Only

**Provides Aeration For:**

<b>Up to 3 Acres</b> .....	6'- 9' deep
<b>Up to 4 Acres</b> .....	9'-12' deep
<b>Up to 6 Acres</b> .....	12'-50' deep

\*Cost per month is calculated at 7c per kilowatt hour. Cost will vary depending on location.



## System Accessories

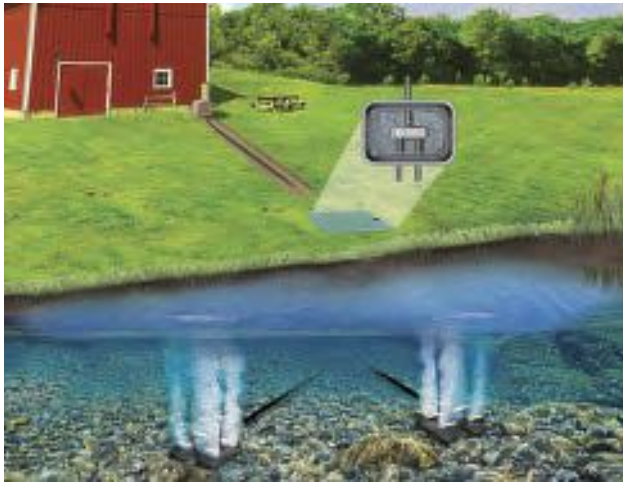

### Remote Manifold Kit

Designed for aeration installations where the power source is away from the pond's edge, the Remote Manifold Kit allows for a single run of direct burial airline from the power source to the pond. This gives you the ability to make airflow adjustments pond side so you can remain in view of the diffusers. All kits include a junction valve box, remote manifold and necessary fittings to connect either 1" poly or PVC pipe.

- #600192 – 2-Port SW20, SW20HP, & PS20 Systems
- #600190 – 3-Port PS30 Systems
- #600194 – 4-Port SW40, SW40HP, & PS40 Systems
- #600193 – 4-Port LS40 Systems
- #600191 – 6-Port LS60 Systems
- #600247 – 8-Port PS80 Systems



### PondSeries Deep Water Kit

The Airmax Deep Water Kit is specifically designed for PondSeries Aeration Systems to allow for operation in water depths greater than 21' deep. With the heavy-duty cam lock connections of the Deep Water Kit, PondSeries Aeration Systems can operate in water depths up to 50'. Kit is setup for 5/8" weighted or 5/8" direct burial airline.

- #510435 – PS10
- #510436 – PS20
- #510437 – PS30
- #510438 – PS40
- #510439 – PS80



### Cabinet Post Mount Kit

Use the Cabinet Post Mount Kit for installations that require the aeration cabinet to be elevated. Constructed of powdered coated aluminum, the mount kit includes mounting bracket and hardware to secure aeration cabinet to both round or square wooden posts, 4" diameter or larger.

- #652121 – Standard Cabinet Post Mount Kit
- #652122 – Large Cabinet Post Mount Kit

### Airmax Under Cabinet Junction Box

Use with any Airmax Aeration System for easy removal or access to line connections underneath the cabinet. The Airmax Under Cabinet Junction Box comes standard with all Airmax LakeSeries Aeration Systems. Measures: 12" W x 17" L x 6" H.



- #490369 – Junction/Valve Box

Existing Airmax Composite Cabinet

Junction/Valve Box

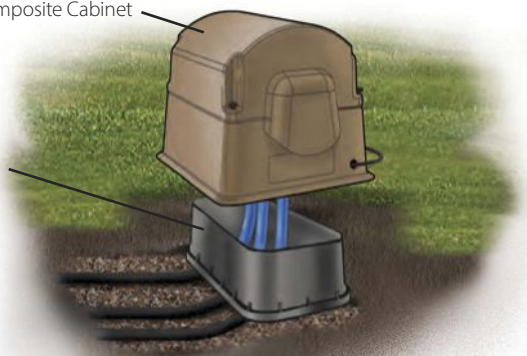

## Cabinets & Compressors

### Shallow Water Series Replacement Parts



#### 1. LR Series SilentAir Compressor

#120912 – LR25 Linear Diaphragm Compressor

#120913 – LR50 Linear Diaphragm Compressor

*Please note: Replacement LR Series compressors have a 2 year warranty.*

#### Maintenance Kits\*

#510147 – LR25 Maintenance Kit

#510148 – LR50 Maintenance Kit

#### 2. Airflow Manifold Assembly

#600177 – SW20 Airflow Manifold Assembly

#600178 – SW40 Airflow Manifold Assembly

#### 3. Cooling Fan

#510345 – Cooling Fan Kit

#### 5. Air Filter

#510158 – LR25 Air Filter, 2 Pack

#510159 – LR50 Air Filter, 2 Pack

#### 4. Cabinet Filter

#510395 – Air Intake Pre-Filter

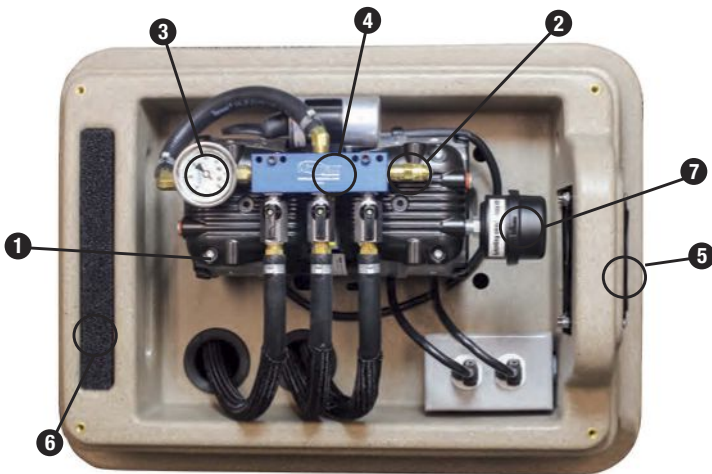

### Shallow Water HP Series, PondSeries & LakeSeries Replacement Parts

#### 1. RP Series SilentAir Rocking Piston Compressor

#510503 – RP25 (87R), 115V

#510504 – RP25 (87R), 230V

#510501 – RP50 (87R), 115V

#510505 – RP50 (87R), 230V

#510502 – RP75 (72R), 115V

#510506 – RP75 (72R), 230V

*Please note: Replacement RP Series compressors have a 1 year warranty.*

#### Maintenance Kits\*

#510108 – RP25 (74R) 1/4 HP

#510510 – RP25 (87R) 1/4 HP

#510111 – RP33 (82R) 1/3 HP

#510115 – RP50 (72R) 1/2 HP

#510511 – RP50 (87R) 1/2 HP

#510512 – RP75 (72R) 3/4 HP

#### 2. Pressure Relief Valve

#490239 – Pressure Relief Valve

#### 3. Pressure Gauge

#490272 – Pressure Gauge

#### 4. Airflow Manifold Assembly

#600244 – SW20HP

#600236 – SW40HP

#600186 – PS10

#600242 – PS20

#600243 – PS30

#600241 – PS40

#600246 – PS80

#600237 – LS40

#600239 – LS60

#### 5. Cooling Fan Kit

#510345 – SW20, SW40, SW20HP, SW40HP, PS10-PS40, 115V

#510344 – SW20HP, SW40HP, PS10-PS40, 230V

#510452 – PS80, LS40, LS60, 115V

#510453 – PS80, LS40, LS60, 230V

#### 6. Cabinet Filter

#510395 – Air Intake Pre-Filter, Standard Cabinet

#510417 – Air Intake Pre-Filter, Large Cabinet

#### 7. Air Filter

#510150 – Air Filter, Complete

#510151 – Air Filter Element Only



**\*Note:** For best results, Airmax recommends preventative maintenance every 6-12 months on all LR Series compressors and every 12-18 months on all RP Series compressors. Visit [airmaxeco.com](http://airmaxeco.com) to view compressor maintenance videos.



## ProAir™ Diffusers

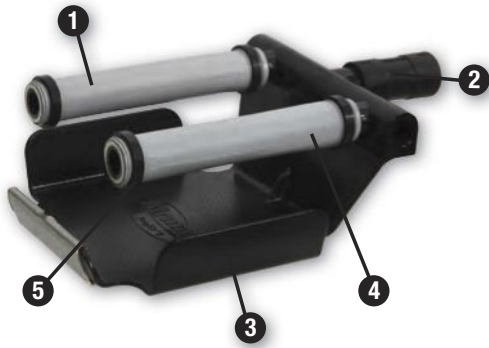

### ProAir 2 Replacement Parts

- 1. #510168 – Complete 6" Membrane Stick
- 2. #490340 – Check Valve
- 3. #490333 – Diffuser Sled w/Stainless Plate
- 4. #610008 – PTFE 6" Membrane Sleeve Only
- 5. #610004 – Membrane Retainer Ring
- \* #490229 – Marine Stainless Hose Clamp
- \* #490227 – 5/8" to 3/4" Insert Reducer Adapter
- \* #490225 – 3/8" to 3/4" Insert Reducer Adapter
- #490354 – Complete ProAir 2 Diffuser

\*Not shown in Diagram

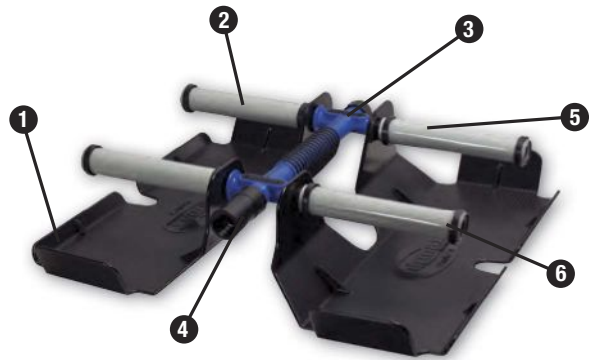

### ProAir 4 Replacement Parts

- 1. #490337 – Single Side Diffuser Sled
- 2. #510168 – Complete 6" Membrane Stick
- 3. #490374 – Diffuser Manifold Handle Assembly
- 4. #490340 – Check Valve
- 5. #610008 – PTFE 6" Membrane Sleeve Only
- 6. #610004 – Membrane Retainer Ring
- \* #490229 – Marine Stainless Hose Clamp
- \* #490227 – 5/8" to 3/4" Insert Reducer Adapter
- \* #490225 – 3/8" to 3/4" Insert Reducer Adapter
- #510166 – Complete ProAir 4 Diffuser

\*Not shown in Diagram



## EasySet™ Airline & Accessories

- 5/8" Weighted
- 3/8" Weighted
- 5/8" Direct Burial



- #510218 – 3/8" Weighted Airline, 25' Roll
- #510130 – 3/8" Weighted Airline, 50' Roll
- #510118 – 3/8" Weighted Airline, 100' Roll
- #510217 – 3/8" Weighted Airline, 500' Spool
- #510119 – 5/8" Weighted Airline, 100' Roll
- #510169 – 5/8" Weighted Airline, 500' Spool
- #510120 – 5/8" Direct Burial Airline, 100' Roll
- #490204 – 3/8" Connector Kit
- #490205 – 3/8" to 5/8" Connector Kit
- #490206 – 5/8" Connector Kit
- #490313 – Airline Caps, Shallow Water, Pond Series
- #490323 – Airline Caps, Lake Series
- #490309 – O-Ring for Airline Caps, Shallow Water, Pond Series



## Security Kit

Cabinet Security Stake Kit includes:  
 (1) 24" unistrut, (1) 2' cable, (1) brass security lock.

#510430 – Cabinet Security Stake Kit

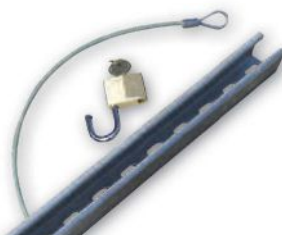

## D-SCALE™

Formerly Fountain and Aeration Cleaner



D-SCALE is a powerful, fast-acting, foaming cleaner that deep cleans and removes limescale, calcium, rust stains and other mineral deposits without scrubbing. This cleaner is 100% biodegradable. Perfect for use on aeration equipment, fountains, spray boats and water pumps.

#530298 – D-SCALE w/ Foaming Tip, 32 oz

#530299 – D-SCALE, 1 Gal.



# EcoSeries™ Fountain

- Energy Efficient
- Industry Leading Spray Patterns
- Maintenance Free Motor Design
- Easy to Install & Maintain

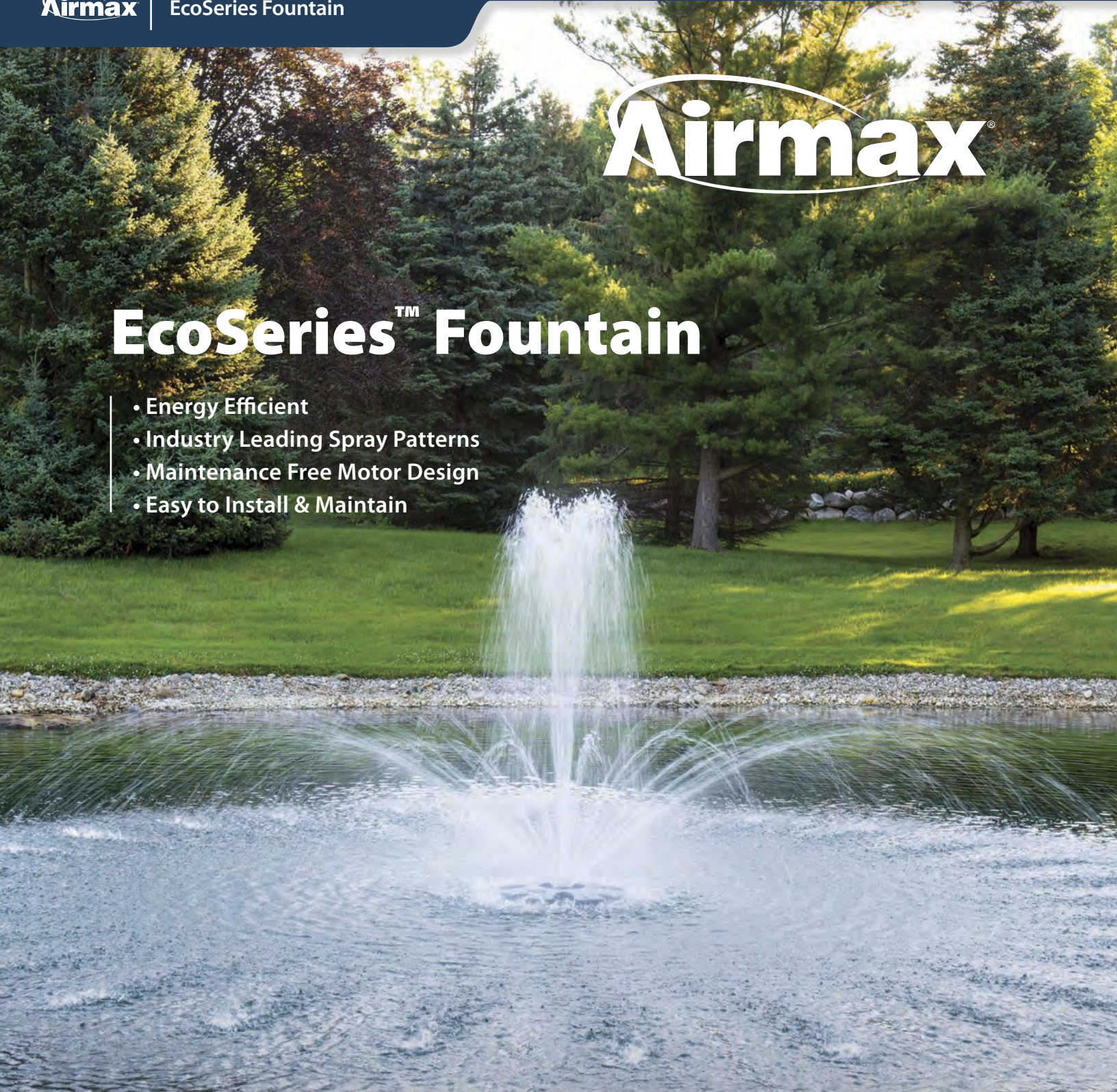

## The EcoSeries Difference

See why an EcoSeries Fountain is the right choice for your pond or lake at [airmaxeco.com/compare](http://airmaxeco.com/compare)





# Airmax® EcoSeries™ ½ HP Fountain



Standard Control Panel w/Timer & Photocell



Power Cord w/Strain Relief

## EcoSeries Fountain Features:

- ½ HP Fountain Pump Operates in as Little as 24" of Water
- Asynchronous Motor, Silicon Carbide (SiC) Shaft Bearing & Ceramic Shaft.
- Stainless Steel Body & Suction Screen
- Stainless Steel Wrapped Motor Lead

## EcoSeries Fountain Kit Includes:

- 3 Spray Patterns: Classic, Trumpet, Crown & Trumpet
- Energy Efficient, Fully Sealed, UL Approved Motor 5.8 Amps, 660 Watts @ 120 Volt
- Standard Control Panel with Timer, GFCI & Photocell for Optional Light Set
- Power Cord with Strain Relief
- Underwater Quick Disconnect

### EcoSeries Fountain Kits

- #652800 - Fountain w/100' Cord
- #652801 - Fountain w/150' Cord
- #652802 - Fountain w/200' Cord
- #652803 - Fountain w/250' Cord
- #652804 - Fountain w/300' Cord
- #652806 - Fountain w/350' Cord
- #652807 - Fountain w/400' Cord

### Also Available with:

**Stainless Steel or Polyflex Protected Cords**

## Accessories

### Airmax® NEMA 3R Control Panel

This lockable, rain tight, NEMA 3R rated Control Panel includes two separate individual 24 hour digital timers and GFCI's for both fountain and lights. The enclosure measures 12" x 12" x 6" and is constructed of powder coated carbon steel for superior corrosion resistance. Need more power? Purchase 115 volt, 8 amp, auxiliary terminal block to run an aeration system or other pond equipment.



- #652105 - Control Panel
- #652106 - Control Panel w/Aux Power

## Mooring Kit

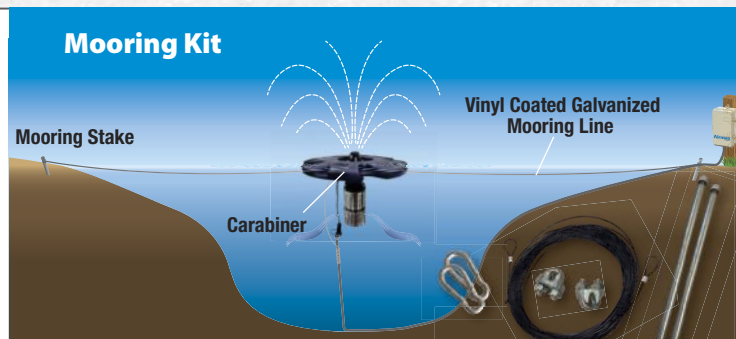

**Kit Includes:** 2 stakes, 2 carabiners, 2 cable clamps, vinyl coated galvanized cable (Mooring Line)

- #651052 - 150' Mooring Kit, (2) 75' sections
- #651054 - 250' Mooring Kit, (2) 125' sections
- #651055 - 500' Mooring Kit, (1) 500' section

#651623 - EcoSeries Filter Sock  
Keeps debris out the of motor without decreasing flow



**Airmax® EcoSeries™ Included Spray Patterns**

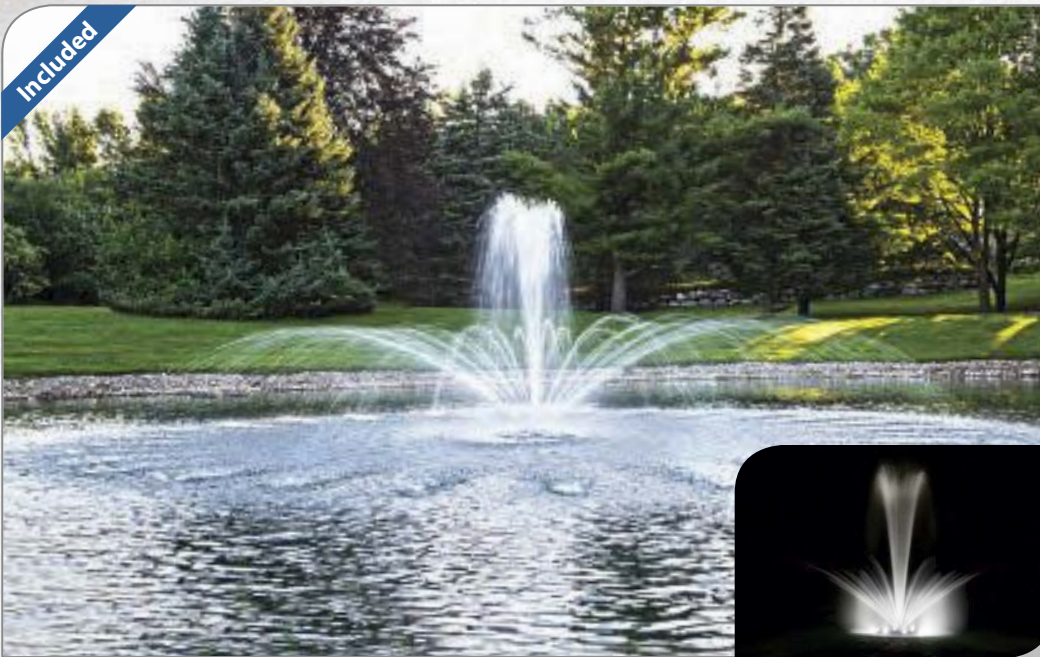

Spray Pattern:

**Crown & Trumpet**

The Airmax Crown & Trumpet pattern combines an arch and trumpet pattern creating a majestic display.

Pattern Dimensions:

Trumpet: **8'h**

Crown: **4' x 32'w**

Item:

**#651703**



See Spray Patterns in action at [airmaxeco.com/ecoseries](http://airmaxeco.com/ecoseries)

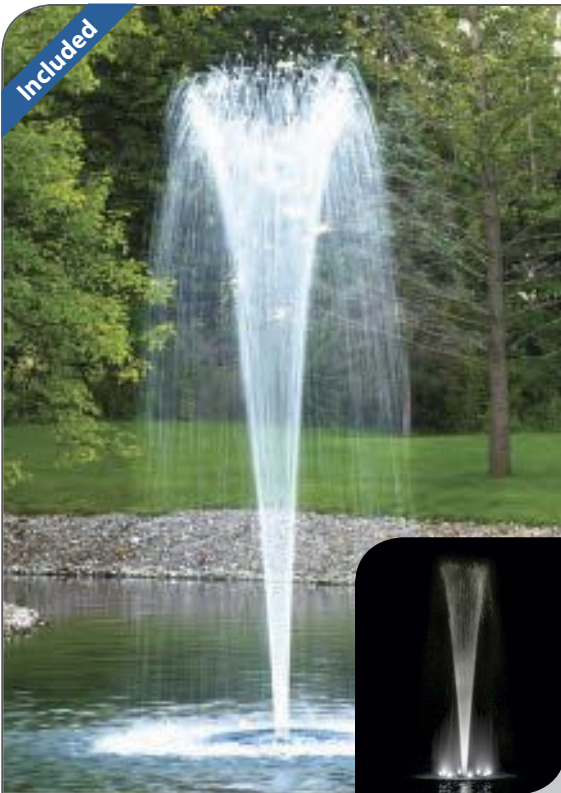

Spray Pattern: **Trumpet**

The Trumpet pattern provides a bountiful tall burst of water giving you the tranquil sound of water.

Pattern Dimensions: **14'h x 7'w**

Item: **#651708**



Spray Pattern: **Classic**

The Classic pattern comes pre-installed on the Airmax EcoSeries Fountain. This beautiful full pattern provides relaxing sounds as the water breaks the surface.

Pattern Dimensions: **6'h x 16'w**

Item: **#651164**



**Optional EcoSeries™ Premium Spray Patterns**

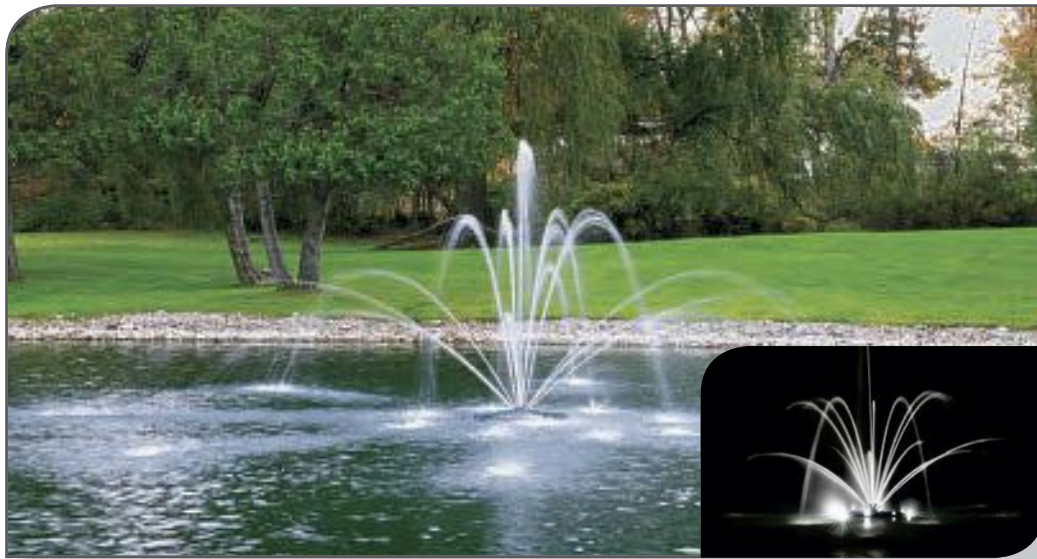

Spray Pattern:  
**Double Arch & Geyser**

Combines the overlapping double arch with a gushing center geyser to create an awe-inspiring display.

Pattern Dimensions:  
Geyser: **9'h**  
1st Tier: **7'h x 12'w**  
2nd Tier: **5'h x 34'w**

Item:  
**#651447**



Spray Pattern:  
**Single Arch**

The Single Arch pattern has heavy streams providing a formal visual display and soothing ambiance.

Pattern Dimensions:  
**8'h x 16'w**  
Item:  
**#651446**

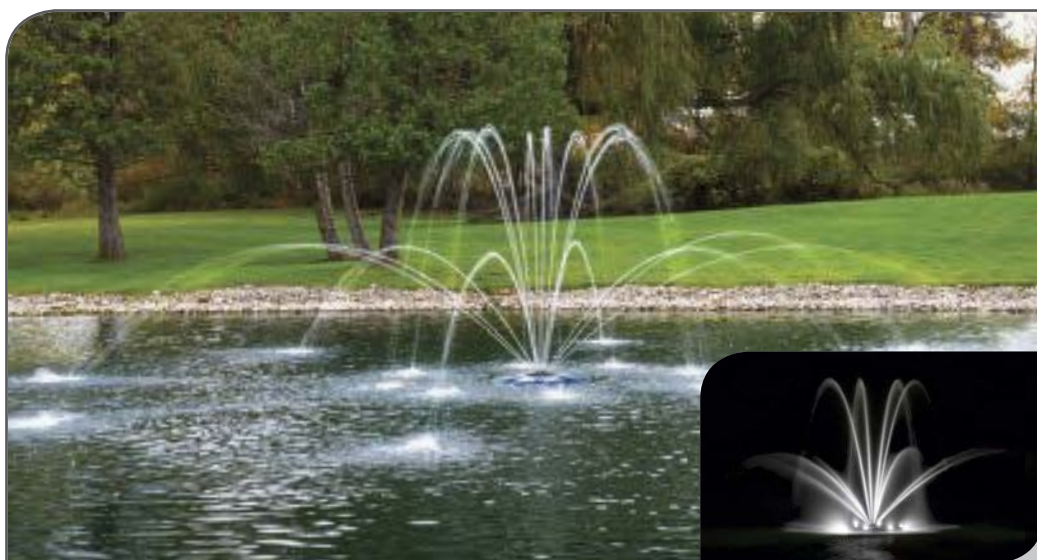

Spray Pattern:  
**Double Arch**

The Double Arch pattern provides two overlapping arch patterns to create a stunning visual presentation. A perfect fit for larger ponds.

Pattern Dimensions:  
1st Tier: **10'h x 16'w**  
2nd Tier: **5'h x 38'w**  
Item:  
**#651445**

# LED Fountain Light Sets

- Low Energy, High Output LED Bulbs
- Fully Adjustable, No Tools Required Snap-on Design
- Above Waterline Design for Maximum Light Output and Low Maintenance



## See Nighttime Displays in Action

See how EcoSeries Fountain LED Light Sets look illuminated at night, visit [airmaxeco.com/ecoseries](http://airmaxeco.com/ecoseries)



Optional LED Fountain Light Sets

RGBW Color-Changing Lights  
RF Remote with 200' Range



4 LED Color Light Set Shown Above



**LED Fountain Light Sets Include:**

- Energy Efficient High Output LED, 120 Volt
- Completely Sealed, Adjustable Above Waterline Design for Low Maintenance.
- All Light Sets Include Stainless Steel Braiding on Power Lead and Between Light Fixtures.
- Power Cords Come Standard with Strain Relief and Underwater Disconnect; 100', 150', 200', 250', 300', 350', 400', 450', 500', 550', & 600' Lengths. Also Available with Stainless Steel and Polyflex Protected Cords.
- Available in 2, 4 & 8 LED Light Sets.
- RF Remote with 200' Range is Included with All RGBW Color-Changing Light Sets
- 3-Year Warranty

**LED Fountain Light Set**



Completely Sealed Fixture with Easy Snap-on Design

**Features:**

All Light Sets Include Stainless Steel Braiding on Power Lead and Between Light Fixtures

The Airmax logo, featuring the word "Airmax" in a bold, sans-serif font with a white outline, set against a dark blue background.A large, dark blue rounded rectangle containing the text "Pond & Lake Water Treatments" in a bold, white, sans-serif font. The background of the entire page is a scenic landscape of a calm pond or lake reflecting a bright blue sky with wispy white clouds. The shoreline is lined with a dense forest of green trees.



# Complete Do-It-Yourself Pond Care System

## ClearPAC® PLUS - DIY Kit

### The Complete Pond Care Program™

ClearPAC PLUS ends the guesswork of pond management by combining essential pond maintenance products into one complete pond care package. ClearPAC PLUS allows pond owners to eliminate algae, improve water quality, reduce pond muck, promote fish health and maintain crystal clear water in a few simple steps.

### ClearPAC PLUS Includes:

- Treats ¼ Acre Pond for up to 6 Months or ½ Acre Pond for up to 3 Months.
- 1 Gallon of Algae Defense
- 24 Packets of PondClear
- 16 Scoops of EcoBoost
- 1 Quart of Nature's Blue Pond Dye
- 8 Scoops of MuckAway

#700110 - ClearPAC PLUS

#700117 - ClearPAC PLUS without Algae Defense



Eb

Nb

Pc

Ad

Ma



# Pond Dye Plus

## Pond Dye Plus Bacteria



- Combined Forces of Pond Dye & PondClear Liquid Natural Bacteria
- One Gallon Treats up to 1 Acre, 4-6' Deep
- Available in 2 Colors
- Safe for All Aquatic & Domestic Life

Pond Dye PLUS combines two superior products, Pond Dye and PondClear Natural Bacteria. Giving a pond a boost of natural bacteria every time pond dye is added will improve water clarity by breaking down suspended organics and nutrients. Available in 2 colors: Provide a true blue color with Nature's Blue or create a deep blue appearance with Twilight Blue. Easy to use and no mixing required. Apply every 4-8 weeks or as needed.

- #570107 • Nature's Blue PLUS, 1 gal.
- #570110 • Twilight Blue PLUS, 1 gal.



# Pond Dye Packets

## Water Soluble Packets



- Easy to Use, Convenient Water Soluble Packets.
- Two Packets Treats up to 1 Acre, 4-6' Deep
- Available in 2 Colors
- Safe for All Aquatic & Domestic Life

Shade your pond with these easy to use water soluble packets. Simply toss one packet in the pond to treat a 1/2 acre of water, 4-6' deep. Available in 2 colors: Provide a true blue color with Nature's Blue or create beautiful reflections with Black DyeMond. Apply every 4-8 weeks or as needed.

- #530356 • Nature's Blue, 2 pkts
- #530359 • Black DyeMond, 2 pkts
- #530357 • Nature's Blue, 4 pkts
- #530360 • Black DyeMond, 4 pkts

# Pond Dye Regular Strength Gallon



- Regular Strength Gallon Treats up to 1 Acre, 4-6' Deep
- Gallons Available in 3 colors
- Safe for All Aquatic & Domestic Life

Protect and shade ponds with pond dye. Provide a true blue color with Nature's Blue, provide a deep blue color with Twilight Blue or create an aqua blue appearance with Aqua Blue. Easy to use and no mixing required. Apply every 4-8 weeks or as needed.

- #530173 • Nature's Blue, 1 gal.
- #530200 • Twilight Blue, 1 gal.
- #250202 • Aqua Blue, 1 gal.

## Pond Dye Color Key





**Pc** PondClear™  
Pond Clarifying Natural Bacteria

- Keeps Ponds Clean & Clear All Season
- Removes Excess Nutrients & Noxious Odors
- Safe for All Aquatic & Domestic Life
- Easy to Use Water Soluble Packets

Keep your pond crystal clear all season long with PondClear Natural Bacteria. PondClear removes excess nutrients and suspended organic waste to improve overall water clarity. Available in a liquid and water soluble packets. 100% natural and safe for all aquatic and domestic life. Use ½ gallon or 2 packets for areas up to ¼ surface acre every 2 weeks when water temperatures are above 50°F.

- #570106 • PondClear, 1 gal - Treats ¼ Acre Pond for up to 1 Month
- #570098 • PondClear, 3 lbs, 12 packets - Treats ¼ Acre Pond for up to 3 Months
- #570100 • PondClear, 6 lbs, 24 packets - Treats ¼ Acre Pond for up to 6 Months
- #570116 • PondClear, 24 lbs, 96 packets - Treats 1 Acre Pond for up to 6 Months



**5 Star Review:** ★★★★★

"I manage a 4 acre retention pond for a small HOA and tried this to help keep the water from looking brown all the time. After a few weeks of use, I could see the water was clearer!"  
- Jack, St. Charles, IL

**Eb** EcoBoost™  
Natural Bacteria Enhancer

- Increases Natural Bacterial Activity & Growth, Improving Water Clarity
- Binds Phosphates & Provides Over 80 Trace Minerals to Promote Fish Health
- Perfect for Use With PondClear & MuckAway
- Safe for All Aquatic & Domestic Life

EcoBoost is a natural bacteria booster designed to increase natural bacterial activity and bind phosphates to improve water quality. This is perfect for ponds that receive excess nutrients from lawn fertilizers, storm drains or ponds that have a muck problem. Apply by stirring powder into a bucket of pond water and evenly distributing around the pond. Use 2 scoops for every ¼ acre and use with PondClear or MuckAway for best results. 100% natural and safe for all aquatic and domestic life.

- #570101 • EcoBoost, 8 lbs, 16 Scoops - Treats ¼ Acre Pond for up to 4 Months
- #570132 • EcoBoost, 24 lbs, 48 Scoops - Treats ¼ Acre Pond for up to 12 Months





# Get Results with MuckAway™

## Fox Lake Case Study

Over 6" of Muck Reduction in Less than 6 Months

**Lake:** Fox Lake is a shallow 9 acre lake characterized by heavy muck, prolific plant growth and stagnant, eutrophic water.

**Action Taken:** MuckAway TL was applied throughout the summer and muck levels were measured multiple times throughout the summer using a Sludge Judge™ and a grid sampling system.

**Results:** Muck Levels showed a decreasing trend resulting in a final average muck reduction of 6.35 inches!

**Full Study:** To see the complete Fox Lake study, please visit [www.airmaxeco.com/foxlake](http://www.airmaxeco.com/foxlake)

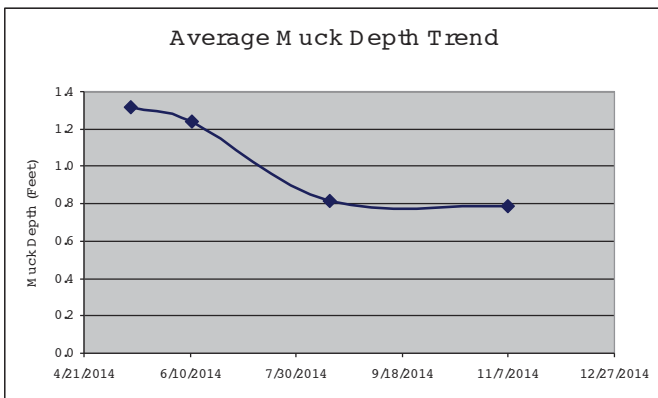

## Before & After with MuckAway

Real Results from Real Customers

**Sanford, Michigan:** A distributor in Sanford, MI treated a beachfront with MuckAway every two weeks from April through September. During the fall, the village of Sanford performed a draw down of the lake to carry out maintenance on the dam. The area that was untreated shows a buildup of muck while the adjacent treated area shows the natural sand bottom.



**Ma** **MuckAway™**  
Muck Reducing Natural Bacteria



- Reduces up to 2" of Muck Per Month
- Perfect for Ponds, Beaches & Shorelines
- Precision Pellets Consume Muck More Effectively Than Using Powder or Liquids
- Safe for All Aquatic & Domestic Life

MuckAway natural bacteria are precision release pellets that sink to the bottom of the pond to digest and convert muck into an odorless gas. MuckAway is perfect for spot treating troublesome areas such as beaches or shorelines. Use one scoop for every 1,000 square feet of shoreline every 2 weeks when water temperatures are above 50°F. MuckAway is 100% natural and safe for all aquatic and domestic life.

- #570108 • MuckAway, 4 lbs, 8 scoops - Treats 75' Shoreline for up to 3 Months
- #570109 • MuckAway, 8 lbs, 16 scoops - Treats 150' Shoreline for up to 3 Months
- #570124 • MuckAway, 24 lbs, 48 scoops - Treats 450' Shoreline for up to 3 Months



**5 Star Review:** ★★★★★

"After only a few treatments, there has been a noticeable reduction of muck in our swimming area. Some spots that had several inches of muck are now sandy, it's great. I would definitely recommend MuckAway."  
- Charley, Vicksburg, MI

**Ma** **MuckAway™ TL**  
Total Lake Muck Reducer

- Reduces up to 2" of Muck Per Month
- Perfect for Total Pond or Lake Applications
- Concentrated Precision Pellets Consume Muck Faster
- Safe for All Aquatic & Domestic Life

MuckAway TL is a concentrated MuckAway formula designed for total pond and lake applications. These precision pellets are so effective they can reduce 1-2" of muck per month when dosed correctly. 12 lbs of MuckAway TL will treat one surface acre regardless of water depth for one month. 100% natural and safe for all aquatic and domestic life. Best used when water temperatures are above 50°F.

- #570113 • MuckAway TL, 36 lbs - Treats 3 Acres for 1 Month



**5 Star Review:** ★★★★★

"My pond is shallow so a total treatment is necessary to keep muck accumulations down. I have seen a great improvement in just 2 months of use!"  
- Henry, Ambrose, GA

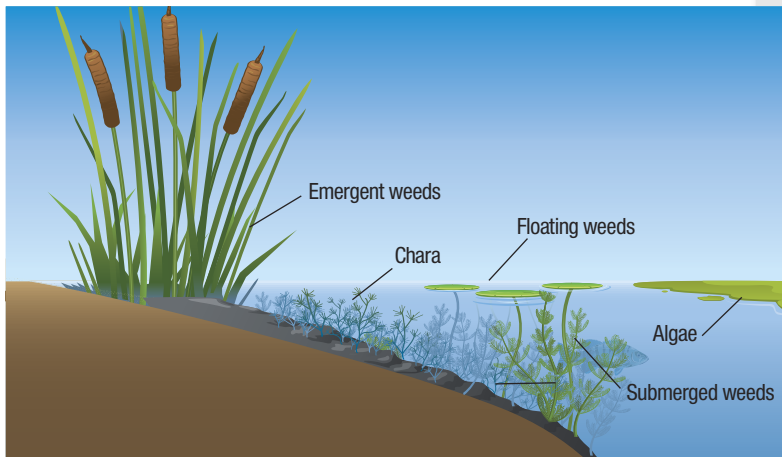

## Identify Your Target

Successful weed control starts with proper identification.

The more mature your pond, the more you have to deal with weeds. They're not only annoying, but they can choke the life out of your delicate ecosystem if action is not taken. You can't treat what you don't know! Identifying those mystery plants is the first step to being successful.

### Two questions to weed out:

- 1. What's the size of treatment area?** Are you battling five acres or a small swim area? It not only affects the amount needed, but which product works best.
- 2. How is the area used?** Swimming? Livestock? Irrigation? Or just a pretty view? Some products have limited or no water use restrictions following treatment.

## Treatment options

Your lines of defense.

Still need help? Call us at:  
866-424-7629



**Algae Defense Algaecide**  
(see page 30)



**Ultra PondWeed Defense Aquatic Herbicide**  
(see page 31)



**WipeOut Aquatic Herbicide**  
(see page 31)



**Shoreline Defense Aquatic Herbicide**  
(see page 29)

## Algae/Chara

Musky Odor, Mats On Pond Surface

Algae is a common nuisance with no defined root system. It often floats on the pond's surface in mats, although it may emerge at the pond's bottom before floating to the surface. Chara looks like a submerged weed, but can be differentiated by its musky smell.

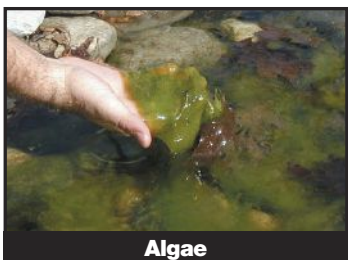

Algae



Chara



## Emergent Weeds

Perimeter Nuisances With Submerged Roots

Majority of plant is emerged out of the water. Emergent weeds are rooted plants that grow along the shoreline and stand above the surface or in shallow areas. A defining characteristic of emergent weeds is the stem, which is most often stiff or firm.



Cattails

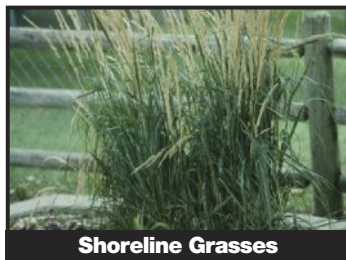

Shoreline Grasses



Phragmites



## Floating Weeds

They Love Shallow Water

Generally found in shallower water, the stem & root system of a "floater" may start at the pond's bottom, although not always. Foliage will be seen floating on the water's surface. If left untreated, they can completely cover the surface cutting off light and oxygen to the fish below.



Watermeal

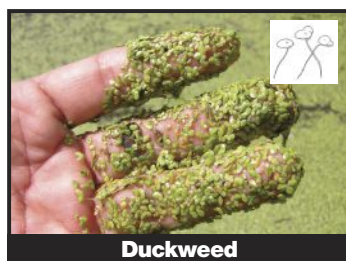

Duckweed



Lily Pads



## Submerged Weeds

Deep Roots Make For Tough Kill

This "iceberg" of weeds is mostly submerged underwater. One discerning characteristic is their soft stem, which is why they don't usually rise above the water's surface.



Curly Leaf Pondweed



Eurasian Watermilfoil



Coontail



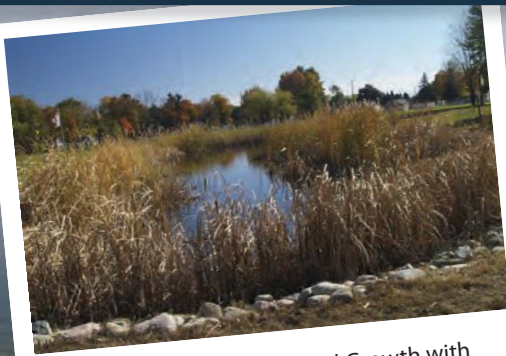

**STEP 1:** Treat Unwanted Growth with Shoreline Defense

**STEP 2:** Cut, Rake & Remove Growth

## **Sd** Shoreline Defense® Broad Spectrum Emergent Weed Control - Systemic Herbicide

- Kills the Roots of Even the Most Persistent Weeds
- Works Great on Cattails, Phragmites, Lilies, Purple Loosestrife & Other Emergent Weeds
- Perfect for Cleaning up Beaches & Shorelines

When persistent emergent weeds are a problem, Shoreline Defense takes care of it. Shoreline Defense is perfect for nuisance cattails, phragmites or other emergent weeds as it not only kills the foliage, it kills the roots for long-term control. For best results, use with Treatment Booster PLUS.

**How to Use:** Mix 8 fl oz of Shoreline Defense, 4 fl oz Treatment Booster PLUS, and 2 gallons of water in a tank sprayer to treat up to 2,500 sq. ft. Spray only on foliage above the water's surface on a calm day to keep spray contained to target areas. Completely wet foliage surface for best results. Always read product label before use.

**Water Use Restrictions:** None

**State Shipping Restrictions:** Shoreline Defense AK, AZ, CA, CT, DC, HI, MA, ME, NJ, NY, PR, RI, VT, WA, or Canada.

**#530157** • Shoreline Defense, 1 qt (32 fl oz) - Treats up to 20,000 sq. ft.

**#530167** • Shoreline Defense, 1 gal (128 fl oz) - Treats up to 80,000 sq. ft.



**For Best Results**  
Add Treatment Booster PLUS!

## Treatment Booster™ PLUS Pond Treatment Enhancer

- Increases Chemical Effectiveness
- Allows Treatment to Penetrate Protective Surface of Aquatic Weeds

Specially formulated to enhance the effectiveness of pond treatments, Treatment Booster PLUS helps adhere the treatment to the target aquatic weed. After adhering to the target, Treatment Booster PLUS works further to allow the treatment to penetrate the aquatic weed's protective surfaces for maximum treatment exposure. Treatment Booster PLUS has also been enhanced to work on underwater weeds and algae by breaking the water's surface tension.

**How to Use:** Mix 2 fl oz of Treatment Booster PLUS with every gallon of treatment solution (chemical & water mixture).

**Water Use Restrictions:** None

**#530172** • Treatment Booster PLUS, 1 pint (16 fl oz)

**#530192** • Treatment Booster PLUS, 1 gal (128 fl oz)





**For Best Results**  
Add Treatment Booster PLUS!

**Ad** **Algae Defense®**  
Kills Algae Fast



- Works on Both Floating & Submerged Algae
- Fast-Acting

Algae Defense is a broad spectrum algaecide that works fast. Algae Defense works as a quick fix to eliminate algae problems. Algae Defense works best when water temperatures reach at least 60°F. Unless steps are taken to reduce the overall nutrients in the pond, multiple applications may be needed for a full season of control. For best results, use with Treatment Booster PLUS.

**How to Use:** Mix 32 fl oz of Algae Defense, 6 fl oz Treatment Booster PLUS, and 2.5 gallons of water in a tank sprayer to treat up to 2,000 sq. ft. Spray algae directly. Only treat up to half of the pond's surface, waiting 10 to 14 days before treating the second half. In hot weather or when fish are stressed, treat ¼ to ½ of the pond at a time. For deeper water place the tank sprayer's tip beneath the water's surface. Always read product label before use.

**Water Use Restrictions:** None

**Other Restrictions:** Do NOT use in ponds with koi, goldfish or trout unless carbonate hardness (KH) is above 50 ppm.

**State Shipping Restrictions:** Algae Defense cannot be shipped to AK, CA, CT, DC, HI, ME, NJ, NY, PR, RI, VT, WA or Canada.

#530130 • Algae Defense, 1 gal (128 fl oz) - Treats up to 8,000 sq. ft.

#160124 • Hardness Test, Single Test



**AlgaeOff®**  
Peroxide-Based Algae Control

- Works On Contact
- Non-Copper Based Algaecide
- Controls Algae

CrystalClear AlgaeOff utilizes the latest in oxygen technology to remove string algae quickly and efficiently. CrystalClear AlgaeOff is a granular algaecide that works on contact. Control of algae is most easily achieved when algae are not yet well established. For best results treat when algae growth first begins to appear.

**How to Use:** Spread 1.5 lbs - 2.5lbs per 500 sq. ft. of treatment area. Treat floating or submerged algae mats evenly from the shoreline out. If the majority of your pond is covered, treat half of the algae infestation; wait 10-14 days before treating the second half. Heavy growth may require re-treatment. Not recommended for Chara treatments. Great for use in ponds containing koi and goldfish. Water temperature has no effect on AlgaeOff but higher temperatures enhance effectiveness. Always read product label before use.

**Water Use Restrictions:** None

**State Shipping Restrictions:** AlgaeOff cannot be shipped to AK, HI, PR or Canada.

#CC074-2 • AlgaeOff, 2.5 lbs - Treats up to 1,000 sq. ft.

#CC074-10 • AlgaeOff, 10 lb - Treats up to 4,000 sq. ft.

#CC074-25 • AlgaeOff, 25 lb - Treats up to 10,000 sq. ft.





**Wo WipeOut™  
Liquid Herbicide**

- Controls Persistent Pond Weeds All Season
- Treats Entire Body of Water in a Single Application
- Effective Herbicide for Floating & Submerged Weeds

WipeOut PondWeed Defense is an herbicide for management of aquatic vegetation in fresh water ponds, lakes, reservoirs, potable water sources, drainage canals and irrigation canals. Pond Logic WipeOut PondWeed Defense Aquatic Herbicide contains fluridone, the same active ingredient found in Sonar A.S. and Avast! SC Aquatic Herbicide.

**How to Use:** Mix 3.8 fluid ounces of Pond Logic WipeOut with water in the included container and apply to the pond in several spots from the shoreline. 3.8 fl. oz. treats a 1/8 surface acre pond with an average depth of 4 ft. Always read product label before use.

**Water Use Restrictions:** WipeOut PondWeed Defense carries a 30 day irrigation restriction.

**State Shipping Restrictions:** WipeOut PondWeed Defense cannot be shipped to AK, CA, CT, DC, HI, ME, NJ, NY, PR, VT, WA or Canada.

**#530250** • WipeOut PondWeed Defense - 4 fl oz - Treats a 1/8 Surface Acre Pond

**#530251** • WipeOut PondWeed Defense - 8 fl oz - Treats a 1/4 Surface Acre Pond



Contains the same active ingredient found in Sonar® A.S. and Avast!® SC Aquatic Herbicides\*\*

**Ultra Pw Ultra PondWeed Defense®  
Broad Spectrum Pondweed Control - Contact Herbicide**

- Works on All Pondweed Including Floating, Submerged & Emerged
- Apply to Actively Growing Plants. May Need to be Reapplied Throughout the Growing Season

Ultra PondWeed Defense is a broad spectrum aquatic herbicide that works on all pondweeds including submerged, floating and emergent weeds. Ultra PondWeed Defense may also be used for short-term control of duckweed. For best results, use on actively growing plants. Emergent treatments may require additional applications to gain full control. For best results, use with Treatment Booster PLUS.

**How to Use:** Mix 16 fl oz of Ultra PondWeed Defense, 4 fl oz Treatment Booster PLUS, and 1.5 gallons of water in a tank sprayer to treat up to 2,500 sq. ft. Spray target directly. Only treat up to half of the pond's surface, waiting 10 to 14 days before treating the second half. In hot weather or when fish are stressed, treat ¼ to ⅓ of the pond at a time. For deeper water place the tank sprayer's tip beneath the water's surface. Always read product label before use.

**Water Use Restrictions:** 3 days drinking, 1 day livestock/domestic animal consumption, 5 day irrigation.

**State Shipping Restrictions:** Ultra PondWeed Defense cannot be shipped to AK, AZ, CA, CT, DC, HI, ME, NJ, NY, PR, RI, VT, WA or Canada.

**#530144** • Ultra PondWeed Defense, 1 qt (32 fl oz) - Treats up to 5,000 sq. ft.

**#530154** • Ultra PondWeed Defense, 1 gal (128 fl oz) - Treats up to 20,000 sq. ft.

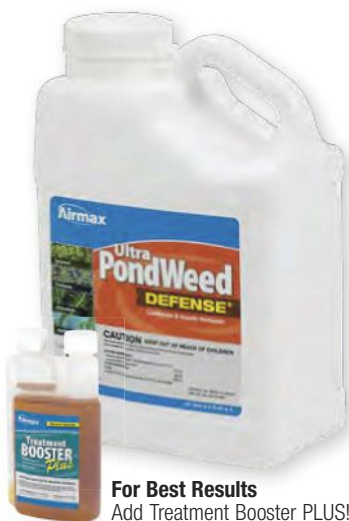

**For Best Results**  
Add Treatment Booster PLUS!

\*\*Avast!® SC and Sonar® A.S. are registered trademarks of SePRO Corp. Pond Logic WipeOut PondWeed Defense Aquatic Herbicide is not manufactured or distributed by SePRO Corp., the manufacturer and seller of Sonar A.S. and Avast! SC Aquatic Herbicide.



**Airmax**<sup>®</sup>

P.O. Box 38 Romeo, MI 48065  
866.424.7629 | [www.airmaxeco.com](http://www.airmaxeco.com)