



Lonestar
Prestress
Manufacturing Inc.

**Pole and Bracket
Product Catalog and
Specifications**

Concrete — The Solid Alternative to Wood

Maintenance Free

Finishes to Enhance or Compliment any Architecture

Power Distribution, Outdoor Lighting, and Security

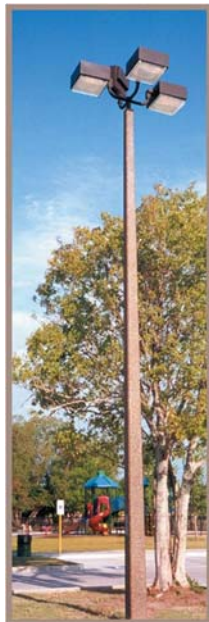

 **Lonestar
Prestress**
Manufacturing Inc.

8892 Highway 159 East
Bellville, Texas 77418

713-896-0994 - lonestarprestress.com

Table of Contents

- I1-3 Glossary of Terms
Product Code

- E1-4 Technical Information
Handling and Installation Procedures
Concrete Pole Specifications

- L1-12 Light Pole
(Type I, II, Octagonal, Simplex, Waterford,
Rochester)

- D1-4 Distribution Pole
(Type III & IV)

- SL1-2 Sport Light Pole

- C1 Camera Pole

- U1-6 Utility Pole

- S1 Standard Pole Finishes

- B1-3 Brackets

Glossary of Terms

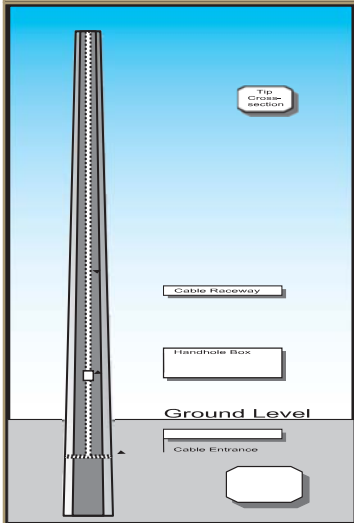

BREAKING STRENGTH

This is the approximate load which, when applied at a point two feet below the tip of the pole, will cause structural failure of the pole.

CONCRETE STRENGTH

This is a reference to the compressive strength of the concrete in pounds per square inch as measured by testing representative samples at twenty-eight days after casting.

DEAD LOAD

This refers to the load on the pole resulting from the attachment of luminaires, luminaire supports and other permanent attachments.

E.P.A "Effective Projected Area"

This is the effective projected area in square feet of luminaires, luminaire supports and other permanently attached items which are subject to wind load.

GROUND LINE

The point at which an embedded poles enters the ground or is otherwise restrained. The point at which a pole with a bolt-down base is attached to the foundation.

GROUND LINE BENDING MOMENT

The product of any horizontally applied load at any point on the pole multiplied by its height above ground line.

LIVE LOADS

These are loads applied to the pole as a result of wind, ice or other loads of temporary nature.

ULTIMATE GROUND LINE BENDING MOMENT

This is the bending moment, applied to the pole which will cause structural failure of the pole. This is the result of multiplying the load indicated in the column titled "Breaking Load" times a distance of two feet less than pole height (length of pole above ground). The ultimate ground line moment is the product of the nominal bending strength multiplied by a strength reduction factor of 0.9 per ACI 318 latest edition. Figures in "Ultimate Ground Line Moment" column assume embedment of 10% of pole length plus two feet; however, these same Moments apply to bolt-down base poles. The figures in this column on technical charts are maximum moments expected to be applied to the pole (or foundation). Appropriate load factors should be used by the designer.

General Information

- 1) Different colors, finishes and exposed aggregate are available upon request.
- 2) Longer lengths of poles available upon request.
- 3) 7000 PSI concrete is standard; higher strengths are available if required.
- 4) STRENGTH: In most cases a higher ground line moment, breaking strength and EPA can be attained without going to a larger pole.
- 5) EFFECTIVE PROJECTED AREA (EPA): Lonestar Prestress Mfg., Inc. concrete poles and mounting arms have been designed in accordance with accepted engineering practices to be structurally capable of withstanding wind loads and velocity pressure using a gust wind speed of at least 140 mph. Poles to meet higher wind loads are available.
- 6) HOLES: Holes are precast to meet your specifications and requirements for mounting attachments, most any desired arrangement can be provided. Contact Lonestar Prestress Mfg. for any questions about field drilling poles.
- 7) INSTALLATION: Lonestar Prestress Mfg. concrete poles are designed for setting directly into the ground, without the use of poured in place foundations, similar to the setting of wood poles. After the hole is drilled, the pole is set and plumbed, the earth is then back-filled and tamped. The depth is dependent on the nature of the soil and the anticipated load. Where it is impossible to embed the poles in the ground, such as on bridges or overpasses, a bolt-down base plate is available.
- 8) To specify a base plate for base mounted poles add the suffix BP to catalog numbers. Customer to supply the bolt circle drawings or template.

Product Code Legend

CONCRETE POLES

The 1st two digits of the product code depicts the size of the pole relative to total length.		The 3rd digit of the product code depicts the type of pole relative to strength and engineering.		The 4th digit of the product code depicts the type of mounting related to the fixture to be used or any other special feature of the pole.		The 5th digit depicts the pole relative to the shape. For brackets (96) the 5th digit depicts length in feet.		The 6th digit of the product code depicts the pole relative to the color and finish.		The 7th digit, after the dash, represents the number of dormant strands in the pole.	
Ex: 35 2001-4		Ex: 35 2 001-4		Ex: 352 0 01-4		Ex: 3520 0 1-4		Ex: 35200 1 -4		Ex: 352001- 4	
CODE	DESCRIPTION	CODE	DESCRIPTION	CODE	DESCRIPTION	CODE	DESCRIPTION	CODE	DESCRIPTION	CODE	DESCRIPTION
10	10 ft. pole	1	Type I	0	Top Mount	1	Octagonal	0	Buff	-0	0 dormant strands
15	15 ft. pole	2	Type II	1	Side Mount	2	Waterford	1	White	-2	2 dormant strands
20	20 ft. pole	3	Type III	2	Tenon Top	3	Tenon Type	2	Gray	-4	4 dormant strands
25	25 ft. pole	4	Type IV	3	Distribution Pole	4	Square Straight	3	Brown	-8	8 dormant strands
30	30 ft. pole	5	Type V Specialty	4	Transmission Pole	5	Stadium	4	Exposed Aggregate		
						0	Square Tapered				
35	35 ft. pole			5	Stadium Pole			5	Black		
40	40 ft. pole			6	Custom Design			6	Special		
45	45 ft. pole			7	No Fixture						
					Solid Concrete						
50	50 ft. pole										
55	55 ft. pole										
60	60 ft. pole										
65	65 ft. pole										
70	70 ft. pole										

Product Code Legend Continued

BRACKETS									
The 1st two digits of the product code depicts the type of product.		The 3rd digit of the product code depicts the number and angle of bracket arms.		The 4th digit of the product code depicts the metal used to make the bracket.		The 5th digit depicts the length in feet.		The 6th digit of the product code depicts the bracket finish.	
Ex: 966967		Ex: 96 6 967		Ex: 966 9 67		Ex: 9669 6 7		Ex: 96696 7	
94	Panel	6	Single arm Single Light	8	Steel	1	1 Foot	6	Special
95	Foundation	7	Double Arm Double Light	9	Aluminum	2	2 Foot	7	Aluminum
96	Bracket	8	Triple Arm 120° Three Light			3	3 Foot	8	Primed
97	Pole Cap	9	Quad Arm 90° Four Light			4	4 Foot	9	Galvanized
99	Stores	0	Custom Design			5	5 Foot		
				6	Clamp Type 6 Foot				
				7	Bull Horn 7 Foot				
				8	Upsweep 8 Foot				
				9	Special 9 Foot				
				0	10 Foot				

Basic Wind Speed ASCE 7-05, Minimum Design Loads for Buildings and Other Structures, American Society of Civil Engineers.

The basic wind speed, V , used in the determination of design wind loads on buildings and other structures, shall be as given in Figure 6-1 of ASCE 7-05.

Strength

Ultimate strength design theory is used to determine the ultimate groundline moments shown in the technical charts. The location of the ultimate ground line moment is determined using an assumed embedment of 10% of the overall length of the pole plus 2 ft. In many cases a higher groundline moment may be attained without going to a larger pole. Please contact our technical staff for special requests.

Wind Loads

Wind loads for determining the maximum effective projected areas (EPA) presented in this catalog were determined in accordance with ASCE 7-05, *Minimum Design Loads for Buildings and Other structures*. The effective projected area is the actual projected area subjected to wind times the appropriate coefficient of drag (Cd). Please note our catalog features EPA's for 90 mph, 110 mph, 130 mph, 140 mph, and 160 mph wind zones. EPA's for higher wind velocities can be attained by special design. Please contact our technical staff for special requests.

Wind pressures determined using the criteria of ASCE 7-05 are based on gust wind speeds. Editions previous to ASCE 7-95 were based on fastest mile (sustained) wind speeds. For example, if your specification calls for the design of a prestressed concrete pole to be based on a wind velocity of 100 mph with a 1.3 gust factor then you would select a pole from our catalog based on a gust wind speed of 130 mph. The following table provides a quick conversion of sustained wind speeds to gust wind speeds using a typical gust factor of 1.3:

Sustained Wind Speed Per ASCE 7-93 (mph)	Sustained Wind Speed Per ASCE 7-93 with 1.3 Gust Factor (mph)	Gust Wind Speed Per ASCE 7-05 (mph)
80	104	110
90	117	120
100	130	130

10% plus 2 foot" Rule of Thumb for the Direct Embedment of Concrete Poles

Pole Length (Ft.)	Embedment (Ft.)	Height Above Grade (Ft.)
15	3.5	11.5
20	4.0	16.0
25	4.5	20.5
30	5.0	25.0
35	5.5	29.5
40	6.0	34.0
45	6.5	38.5
50	7.0	43.0
55	7.5	47.5
60	8.0	52.0
65	8.5	56.5
70	9.0	61.0

The hole diameter selected for the embedment should allow a minimum clearance around the corners of the pole butt of 4 to 6 inches. Hole sizes are generally specified in 6 inch increments to accommodate standard auger sizes. The hole diameter for octagonal poles may be determined by adding 8 to 12 inches to the width of the pole butt.



Handling and Installation Procedures

Handling Instructions

- Prestressed concrete poles will withstand a considerable amount of bending but should not be shock loaded while under load.
- Prestressed concrete poles should never be handled or picked up by the tip.
- When shipping poles, the poles should be supported at a minimum of 3 points for poles up to and including 40 feet and 4 points for poles over 40 feet.
- Poles up to 50 feet in length may be unloaded using a one-point pickup at the balance point but should never be transported in this manner. A two-point pickup must be used to transport a pole at the job site.

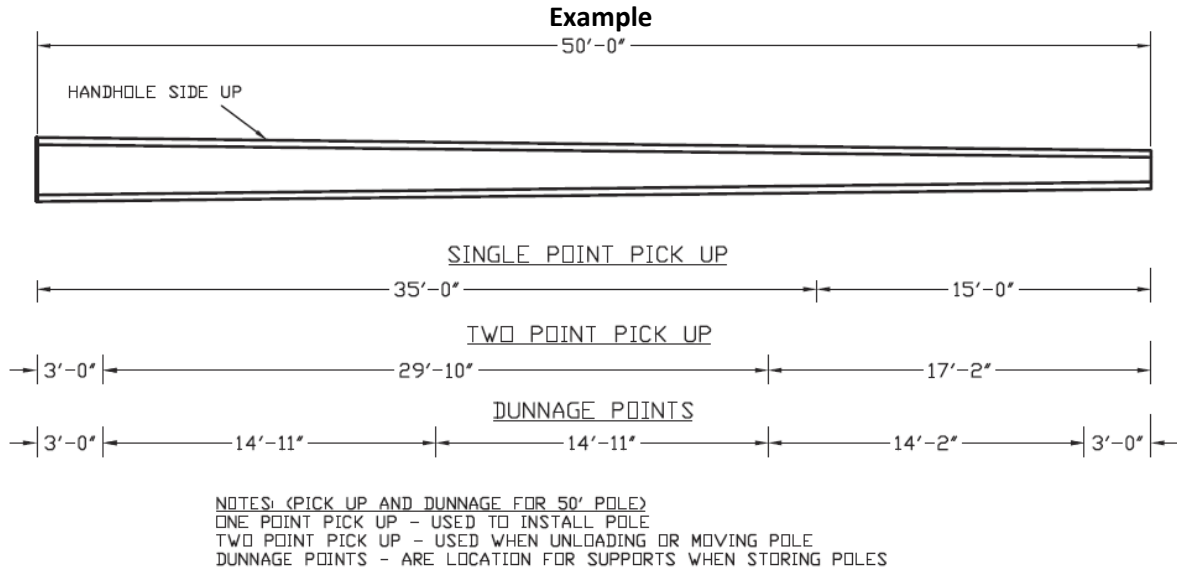

Installation Procedure

- Prior to installation of the pole, electrical wiring, brackets and luminaries can be installed while the pole is lying horizontally on the ground.
- Excavate the proper diameter and depth hole. The preferred method of excavation is by auger type drilling.
- To install, choke the pole with one end of a nylon sling 25% to 30% of the pole length from the top (see Handling section for location). Attach the other end of the sling to the lifting hook of the crane.
- Lift the pole allowing the butt to rest on the ground until vertical.
- Lift the pole over hole and lower until butt rests on bottom center of hole.
- While holding pole, add backfill in 4 to 6 inch layers, tamping between placement of each layer. Check for plumbness throughout the backfilling process.
- If the pole is equipped for an underground connection, stop backfilling to a point 6 inches below the connection. Make the connection and then finish backfilling the hole to a point 2 inches above grade.

Direct Embedment

Direct embedment is the most common and recommended method of installation of prestressed concrete poles. Soil conditions vary from location to location and should be investigated by an engineer prior to designing the foundation. The “rule of thumb” for the depth of embedment is 10% of the overall length plus two feet. The table on the preceding page is based on the “rule of thumb.” Depending upon the type of soil, an appropriate backfill should be selected. The chart below contains suggested guidelines for the selection of backfill:

<p>Good Soil: Compacted well graded sand and gravel, hard clay or well graded fine and course sand.</p>	<p>The excavated soil may be used as the backfill.</p>
<p>Medium Soil: Compacted fine sand and clay, compact sandy loam, loose coarse sand and gravel.</p>	<p>Requires select backfill. Clean, washed sand or minus 1/ 2 inch well graded gravel may be used.</p>
<p>Poor Soil: Soft clay, clay loam, poorly compacted sand or clays containing large amounts of silt.</p>	<p>Requires one of the following: cementitious earth, cement stabilized sand, limestone screenings, or urethane foam.</p>

1.00 SCOPE

1.10 This specification is to establish design and quality standards for static cast concrete poles for power distribution or lighting. All pole design structural calculations shall be prepared by a licensed engineer experienced in prestressed concrete design.

2.00 GENERAL

2.10 The concrete poles furnished under these specifications shall be designed and manufactured in accordance with requirements and/or recommendations of the American Concrete Institute Standard "Building Code Requirements for Structural Concrete" (ACI 318 - Latest Edition), unless otherwise specified.

2.20 Poles shall be designed in accordance with the Prestressed Concrete Institute "Guide for Design of Prestressed Concrete Poles."

3.00 PHYSICAL CHARACTERISTICS

3.10 All poles shall be prestressed concrete and suitable for direct embedment into the ground without special foundations.

3.20 Shape and Length: Poles shall be square in cross-section, with chamfered corners, and shall have a standard taper of 0.162 inch per foot. Cross-sectional dimensions shall not deviate by more than 3/8 inch. The allowable tolerance for overall length shall be +3 inches and -2 inches. The width of the bottom face of the pole (as it is cast) may be less than the top face.

3.30 Finish: The pole shall have a smooth uncolored finish with no cracks. The top surface of each pole shall be troweled until all projections, depressions, and irregularities have been removed and the entire surface has a smooth texture and neat lines. Square corners and sharp edges shall be tooled to form smooth, chamfered corners.

All small cavities shall be cleaned, saturated with water and then filled with mortar. A small cavity is defined as one larger than 1/4 inch but smaller than 3/4 inch in diameter, and less than 3/8 inch deep. Larger non-structural cavities and spalls shall be repaired by opening the side of the damaged area on a 1 to 1 slope using a mechanical grinder, cleaning thoroughly and filling with a high-strength non-shrink concrete repair material. Poles with other defects may be repaired only upon authorization of, and using the method prescribed by the Design Engineer.

3.40 Sealing Steel Strands: The end of each steel reinforcing strand (in the top and butt) shall be burned back to a minimum depth of 1/2 inch. The holes left by the removal of the strand shall be thoroughly cleaned of any loose residue. The holes shall then be completely filled with non-shrink grout and smoothed evenly with tip or butt surface.

3.50 Cover: The prestressing strands shall have a minimum concrete cover of 1 inch, except that Type I poles will have a minimum cover of 3/4 inch. The centerline axis along the faces of the poles shall be clear of embedded steel except for stirrups, spiral reinforcement and fabrication devices, so that 3/4 inch diameter holes may be drilled without interference from the strands.

3.60 Sweep: Sweep is the deviation of a pole from straightness. A straight line joining the edge of the pole at the butt and the edge of the pole at the top shall not be distant from the surface of the pole at any point by more than 3/8 inch for each 10 feet of length.

3.70 Hole Drilling: Poles shall be drilled in accordance with approved drawings. The location of holes shall not deviate by more than 3/8 inch. Holes drilled after removal from molds shall be drilled from both sides of the pole and shall be uniform in entrance and exit. Holes drilled from opposing sides of the pole must be in the same plane and be centered on both faces.

3.80 Cable Entrances: Two cable entrances with couplings shall be cast in all poles 90 degrees to the handhole unless otherwise specified by the customer.

Concrete Pole Specifications

4.00 MATERIALS

4.10 Chloride Content: The chloride content of the concrete mix, including all ingredients, shall be 0.4 pounds per cubic yard, or less.

4.20 Corrosion Resistance: All inserts or attachments, if required, shall be of noncorrosive material or galvanized.

4.30 Concrete: Concrete used in poles shall have a compressive strength at transfer of not less than 4,000 PSI, and a 28-day compressive strength of not less than 7,000 PSI, unless otherwise specified.

4.40 Material shall comply with the most recent revision of the following ASTM Standards:

- | | |
|------------------------------|------------------|
| a) Portland Cement | ASTM C105 |
| b) Admixtures | ASTM C494 |
| c) Aggregates | ASTM C33 or C330 |
| d) Reinforcing Bars | ASTM A615 |
| e) Cold Drawn Spiral Wire | ASTM A82 |
| f) Prestressing Strand, 270K | ASTM A416 |

5.00 STRENGTH REQUIREMENTS

5.10 Poles of each standard type, unless otherwise specified, shall be designed to withstand the rated design (cracking) and ultimate strength shown in the following tables, with modifications to accommodate allowances for handling, transportation and erection. The rated strength is that load which, if applied, in a direction perpendicular to the axis 2 feet below the pole tip and with the bottom of the pole (ten percent of its length plus two feet from the butt) held firm, will produce the first sign of hairline cracks. The ultimate strength is the load at which point failure occurs.

5.20 All poles shall be capable of withstanding single point pickup from the horizontal position when lifting from a point 30% of the overall length down from the tip.

6.00 GROUNDING

6.10 A PVC conduit for customer to pull a ground wire through can be cast in poles if required by the customer and included with bid to customer.

7.00 QUALITY CONTROL

7.10 Tests shall be made and records shall be maintained in accordance with the requirements of Prestressed Concrete Institute MNL-116, "Manual for Quality Control for Plants and Production of Precast Prestressed Concrete Products."

8.00 DRAWING AND DESIGN INFORMATION

8.10 Upon request, Lonestar Prestress Mfg., Inc. will furnish detailed design drawings and computations for the poles bid or supplied, including but not limited to the following:

- 1) Total weight and center of gravity of each pole.
- 2) Calculations of cracking and ultimate moment capacities at not more than 5 foot intervals.
- 3) Dunnage and pickup points, including both one-point and two-point pickup locations.
- 4) Detail of cross section and all points where reinforcing changes.

9.00 INSTALLATION

9.10 Poles shall be supported and protected during site storage, lifting and setting to prevent damage to the pole. Spalls or other damage incurred during these operations shall be repaired to restore the pole to "as new" condition.

Type I Technical Chart

Used for Street Lighting, Parking Lot and Security Lighting,
Recreational and Industrial Lighting



Direct Embedment

CATALOG NUMBER SMOOTH GRAY	MOUNTING HEIGHT (Ft.)	POLE WEIGHT (Lbs.)	OVERALL LENGTH (Ft.)	POLE SIZE (In.)		EPA AT POLE TIP (Sq. Ft.)					ULTIMATE GROUNDLINE MOMENT (Ft. Lbs.)	BREAKING LOAD 2 Ft. FROM TIP (Lbs.)
				TIP	BUTT	90 MPH	110 MPH	130 MPH	140 MPH	160 MPH		
151002	11.5	414	15.0	4.0	6.44	58	38	26	22	16	11,100	1,168
201002	16.0	649	20.0	4.0	7.25	51	32	22	18	13	14,400	1,028
251002	20.5	942	25.0	4.0	8.06	44	27	17	14	9	17,300	935
301002	25.0	1,302	30.0	4.0	8.88	37	22	13	10	6	19,800	861
351002	29.5	1,735	35.0	4.0	9.69	32	18	10	7	3	22,300	811
401002	34.0	2,246	40.0	4.0	10.50	28	15	7	5	1	24,800	775

General Information

1. Different colors, finishes and exposed aggregates are available upon request.
2. Longer lengths of poles available upon request.
3. All corners are chamfered.
4. 7,000 PSI gray concrete is standard; higher strengths are available if required. The EPA's listed for poles using 7,000 psi concrete shall be reduced by 15% when decorative mixes are used.
5. STRENGTH: In most cases a higher ground line moment and a higher breaking strength and EPA can be attained without going to a larger pole.
6. EFFECTIVE PROJECTED AREA (EPA): Lonestar Prestress Mfg. concrete poles and mounting arms have been designed in accordance with accepted engineering practices to be structurally capable of withstanding wind loads and velocity pressure per ASCE 7-05. Poles to meet higher wind loads are available.
7. HOLES: Holes are precast to meet your specifications and requirements for mounting attachments, most any desired arrangement can be provided. Contact Lonestar Prestress Mfg. for any questions about field drilling light poles.
8. INSTALLATION: Lonestar Prestress Mfg. concrete poles are designed for setting directly into the ground, without the use of precast foundations, similar to the setting of wood poles. After the hole is drilled, the pole is set and plumbed, the earth is then backfilled and tamped. The depth is dependent on the nature of the soil and the anticipated load. Where it is impossible to embed the poles in the ground, such as on bridges or overpasses, a bolt-down base plate is available.
9. To specify a base plate for base mounted poles add the suffix BP to catalog numbers. Customer to supply the bolt circle drawings or template.



Type I Pole

Type I Typical Details

POLE	BUTT
15 FT.	6.44"x6.44"
20 FT.	7.25"x7.25"
25 FT.	8.06"x8.06"
30 FT.	8.88"x8.88"
35 FT.	9.69"x9.69"
40 FT.	10.50"x10.50"

- WE ARE NOT RESTRICTED TO THESE STANDARD DETAILS AND WELCOME ANY SPECIAL DESIGNS. YOU MAY USE THE STANDARD DRAWING TO MARK UP AND SEND TO YOUR SALES REPRESENTATIVE OR SEND DIRECTLY TO US.
- CABLE ENTRANCE AVAILABLE WITH CONDUIT COUPLINGS.

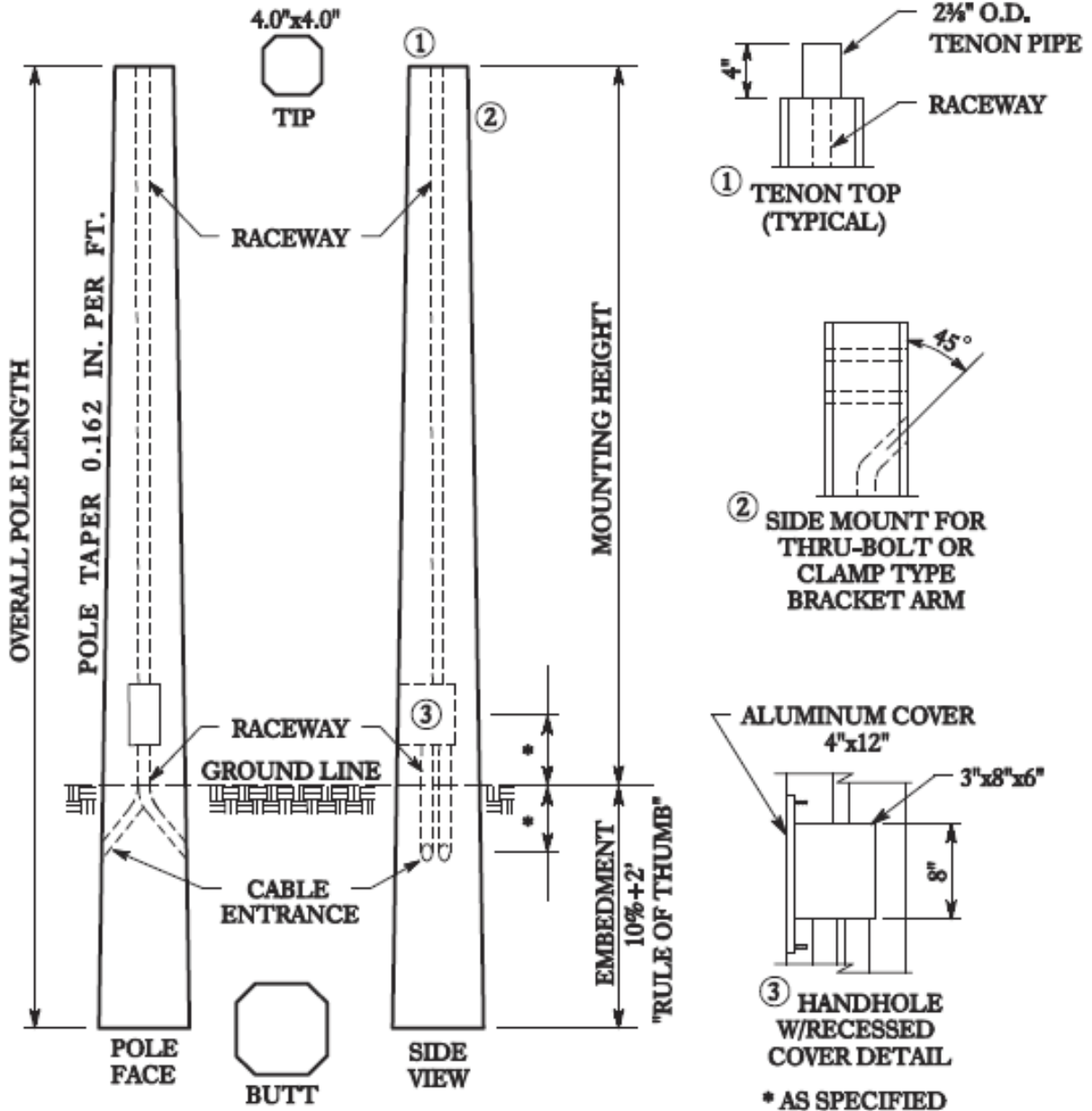

Type II Technical Chart

Used for Street Lighting, Parking Lot and Security Lighting, Recreational and Industrial Lighting

Direct Embedment

CATALOG NUMBER SMOOTH GRAY	MOUNT- ING HEIGHT (Ft.)	POLE WEIGHT (Lbs.)	OVERALL LENGTH (Ft.)	POLE SIZE (In.)		EPA AT POLE TIP (Sq. Ft.)					ULTIMATE GROUNDLINE MOMENT (Ft. Lbs.)	BREAKING LOAD 2 Ft. FROM TIP (Lbs.)
				TIP	BUTT	90 MPH	110 MPH	130 MPH	140 MPH	160 MPH		
252002-0	20.5	1667	25.0	6.0	10.06	102	65	44	37	26	38,100	2,059
302002-0	25.0	2,220	30.0	6.0	10.88	88	55	36	30	20	43,100	1,873
352002-0	29.5	2,863	35.0	6.0	11.69	77	47	30	24	15	47,900	1,741
402002-0	34.0	3,601	40.0	6.0	12.50	68	40	25	19	11	52,900	1,653
452002-0	38.5	4,442	45.0	6.0	13.31	61	35	20	15	7	57,700	1,580
502002-0	43.0	5,392	50.0	6.0	14.13	54	29	15	10	3	62,500	1,524
552002-4	47.5	6,537	55.0	6.0	14.94	98	58	35	27	15	114,900	2,525
602002-4	52.0	7,732	60.0	6.0	15.75	94	55	32	27	12	127,000	2,540
652002-4	56.5	9,055	65.0	6.0	16.56	89	50	28	20	9	137,900	2,530
702002-4	61.0	10,514	70.0	6.0	17.38	84	45	24	16	5	147,700	2,503

General Information

1. Different colors, finishes and exposed aggregates are available upon request.
2. Longer lengths of poles available upon request.
3. All corners are chamfered.
4. 7,000 PSI gray concrete is standard; higher strengths are available if required. The EPA's listed for poles using 7,000 psi concrete shall be reduced by 15% when decorative mixes are used.
5. STRENGTH: In most cases a higher ground line moment and a higher breaking strength and EPA can be attained without going to a larger pole.
6. EFFECTIVE PROJECTED AREA (EPA): Lonestar Prestress Mfg. concrete poles and mounting arms have been designed in accordance with accepted engineering practices to be structurally capable of withstanding wind loads and velocity pressure per ASCE 7-05. Poles to meet higher wind loads are available.
7. HOLES: Holes are precast to meet your specifications and requirements for mounting attachments, most any desired arrangement can be provided. Contact Lonestar Prestress Mfg. for any questions about field drilling light poles.
8. INSTALLATION: Lonestar Prestress Mfg. concrete poles are designed for setting directly into the ground, without the use of precast foundations, similar to the setting of wood poles. After the hole is drilled, the pole is set and plumbed, the earth is then backfilled and tamped. The depth is dependent on the nature of the soil and the anticipated load. Where it is impossible to embed the poles in the ground, such as on bridges or overpasses, a bolt-down base plate is available.
9. To specify a base plate for base mounted poles add the suffix BP to catalog numbers. Customer to supply the bolt circle drawings or template.



Type II Pole

POLE	BUTT
25 FT.	10.06"x10.06"
30 FT.	10.88"x10.88"
35 FT.	11.69"x11.69"
40 FT.	12.50"x12.50"
45 FT.	13.31"x13.31"
50 FT.	14.13"x14.13"
55 FT.	14.94"x14.94"
60 FT.	15.75"x15.75"
65 FT.	16.56"x16.56"
70 FT.	17.38"x17.38"

Type II Typical Details

- WE ARE NOT RESTRICTED TO THESE STANDARD DETAILS AND WELCOME ANY SPECIAL DESIGNS. YOU MAY USE THE STANDARD DRAWING TO MARK UP AND SEND TO YOUR SALES REPRESENTATIVE OR SEND DIRECTLY TO US.
- CABLE ENTRANCE AVAILABLE WITH CONDUIT COUPLINGS.

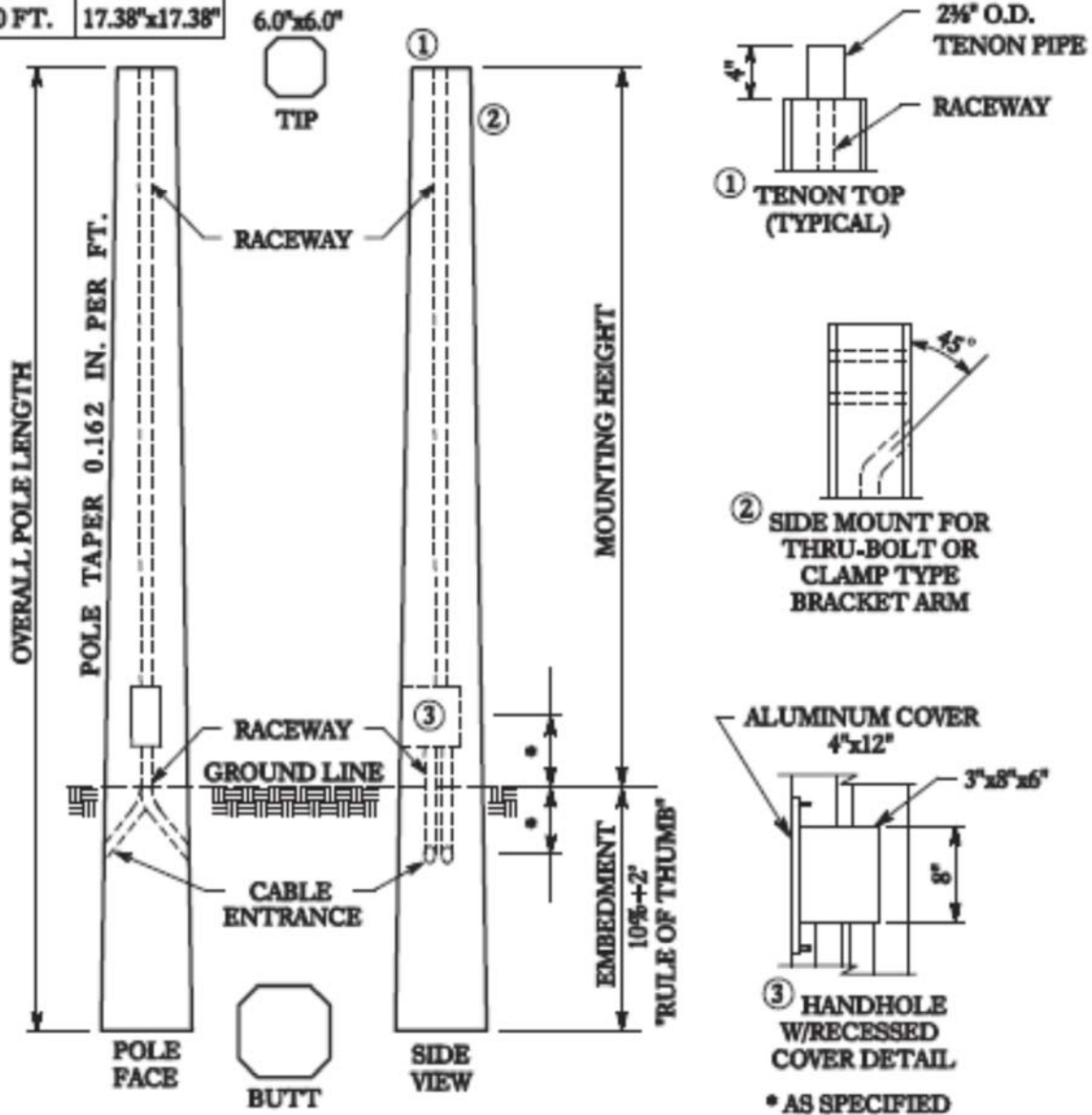



Type I Octagonal Technical Chart

Used for Street Lighting, Parking Lot and Security Lighting, Recreational and Industrial Lighting

Direct Embedment

CATALOG NUMBER SMOOTH GRAY	MOUNTING HEIGHT (Ft.)	POLE WEIGHT (Lbs.)	OVERALL LENGTH (Ft.)	POLE SIZE (In.)		EPA AT POLE TIP (Sq. Ft.)					ULTIMATE GROUNDLINE MOMENT (Ft. Lbs.)	BREAKING LOAD 2 Ft. FROM TIP (Lbs.)
				TIP	BUTT	90 MPH	110 MPH	130 MPH	140 MPH	160 MPH		
151012	11.5	450	15.0	5.0	6.83	49	31	21	18	13	9,400	989
201012	16.0	668	20.0	5.0	7.44	41	26	1	14	9	11,600	828
251012	20.5	924	25.0	5.0	8.05	34	20	13	10	6	13,700	740
301012	25.0	1,221	30.0	5.0	8.66	29	17	10	7	4	15,900	691
351012	29.5	1,565	35.0	5.0	9.27	24	13	7	5	1	17,700	643
401012	34.0	1,956	40.0	5.0	9.88	20	10	4	2	0	19,400	606

General Information

1. Different colors, finishes and exposed aggregates are available upon request.
2. Longer lengths of poles available upon request.
3. All corners are chamfered.
4. 7,000 PSI gray concrete is standard; higher strengths are available if required. The EPA's listed for poles using 7,000 psi concrete shall be reduced by 15% when decorative mixes are used.
5. STRENGTH: In most cases a higher ground line moment and a higher breaking strength and EPA can be attained without going to a larger pole.
6. EFFECTIVE PROJECTED AREA (EPA): Lonestar Prestress Mfg. concrete poles and mounting arms have been designed in accordance with accepted engineering practices to be structurally capable of withstanding wind loads and velocity pressure per ASCE 7-05. Poles to meet higher wind loads are available.
7. HOLES: Holes are precast to meet your specifications and requirements for mounting attachments, most any desired arrangement can be provided. Contact Lonestar Prestress Mfg. for any questions about field drilling light poles.
8. INSTALLATION: Lonestar Prestress Mfg. concrete poles are designed for setting directly into the ground, without the use of precast foundations, similar to the setting of wood poles. After the hole is drilled, the pole is set and plumbed, the earth is then backfilled and tamped. The depth is dependent on the nature of the soil and the anticipated load. Where it is impossible to embed the poles in the ground, such as on bridges or overpasses, a bolt-down base plate is available.
9. To specify a base plate for base mounted poles add the suffix BP to catalog numbers. Customer to supply the bolt circle drawings or template.



Type I Octagonal Pole

POLE	BUTT
15 FT.	6.83"x6.83"
20 FT.	7.44"x7.44"
25 FT.	8.05"x8.05"
30 FT.	8.66"x8.66"
35 FT.	9.27"x9.27"
40 FT.	9.88"x9.88"

Type I Octagon Typical Details

- WE ARE NOT RESTRICTED TO THESE STANDARD DETAILS AND WELCOME ANY SPECIAL DESIGNS. YOU MAY USE THE STANDARD DRAWING TO MARK UP AND SEND TO YOUR SALES REPRESENTATIVE OR SEND DIRECTLY TO US.
- CABLE ENTRANCE AVAILABLE WITH CONDUIT COUPLINGS.

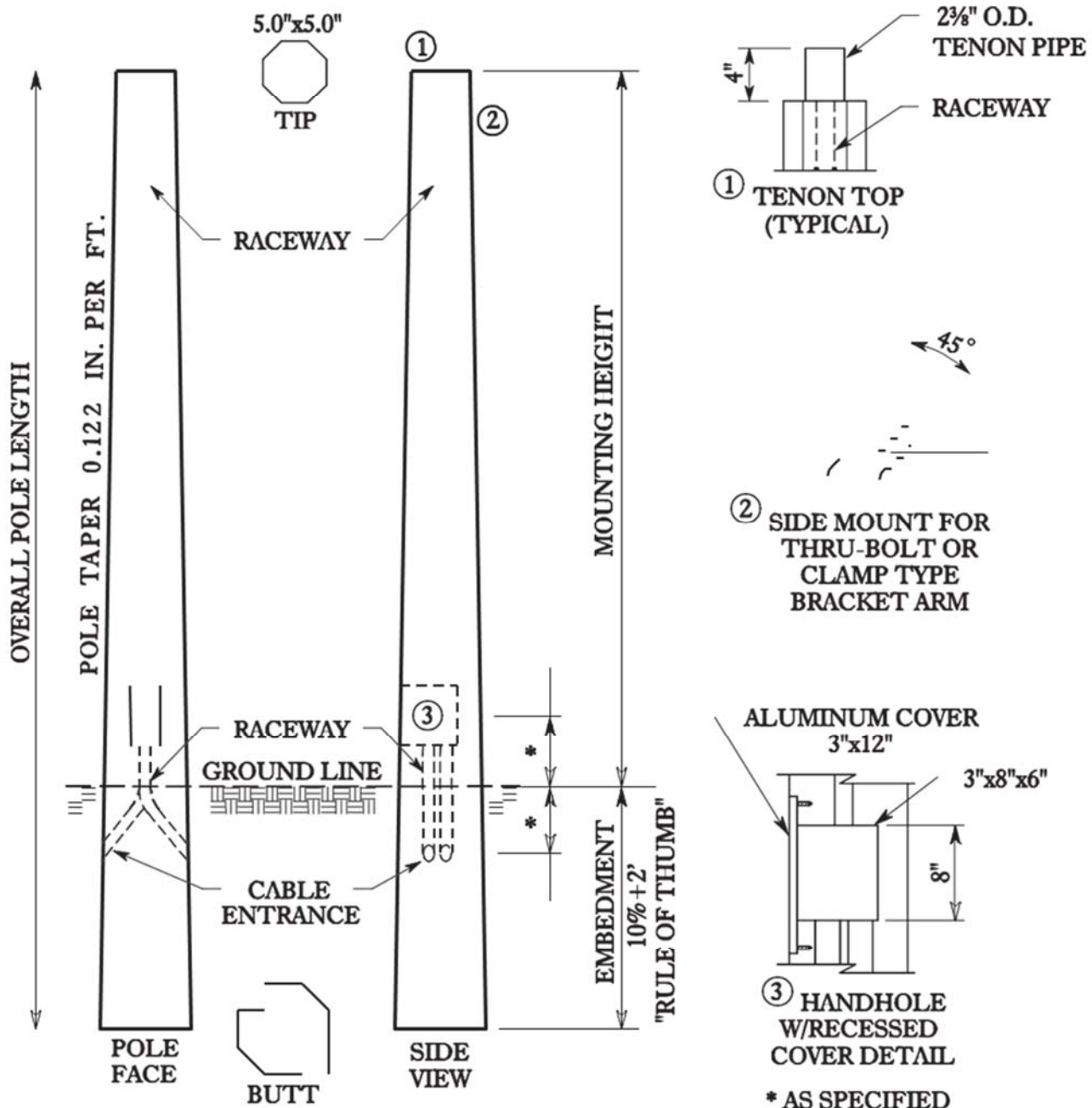

Type I Simplex Technical Chart

Used for Street Lighting

Direct Embedment

CATALOG NUMBER SMOOTH GRAY	MOUNTING HEIGHT (Ft.)	POLE WEIGHT (Lbs.)	OVERALL LENGTH (Ft.)	POLE SIZE (In.)		EPA AT POLE TIP (Sq. Ft.)					ULTIMATE GROUNDLINE MOMENT (Ft. Lbs.)	BREAKING LOAD 2 Ft. FROM TIP (Lbs.)
				TIP	BUTT	90 MPH	110 MPH	130 MPH	140 MPH	160 MPH		
181602	14.2	718	18.0	4.8	7.73	54	34	23	19	14	16,500	1,1352
231602	18.7	1,050	23.3	4.8	8.54	47	29	19	16	11	19,000	1,137
281602	23.2	1,451	28.0	4.8	9.35	40	24	15	12	7	21,500	1,014
301602	25.0	1,633	30.0	4.8	9.68	37	22	13	10	6	22,500	978
331602	27.7	1,929	33.0	4.8	10.16	34	20	11	9	4	24,000	933
351602	29.5	2,150	35.0	4.8	10.5	32	18	10	7	3	22,200	807

General Information

1. Different colors, finishes and exposed aggregates are available upon request.
2. Longer lengths of poles available upon request.
3. All corners are chamfered.
4. 7,000 PSI gray concrete is standard; higher strengths are available if required. The EPA's listed for poles using 7,000 psi concrete shall be reduced by 15% when decorative mixes are used.
5. STRENGTH: In most cases a higher ground line moment and a higher breaking strength and EPA can be attained without going to a larger pole.
6. EFFECTIVE PROJECTED AREA (EPA): Lonestar Prestress Mfg. concrete poles and mounting arms have been designed in accordance with accepted engineering practices to be structurally capable of withstanding wind loads and velocity pressure per ASCE 7-05. Poles to meet higher wind loads are available.
7. HOLES: Holes are precast to meet your specifications and requirements for mounting attachments, most any desired arrangement can be provided. Contact Lonestar Prestress Mfg. for any questions about field drilling light poles.
8. INSTALLATION: Lonestar Prestress Mfg. concrete poles are designed for setting directly into the ground, without the use of precast foundations, similar to the setting of wood poles. After the hole is drilled, the pole is set and plumbed, the earth is then backfilled and tamped. The depth is dependent on the nature of the soil and the anticipated load. Where it is impossible to embed the poles in the ground, such as on bridges or overpasses, a bolt-down base plate is available.
9. To specify a base plate for base mounted poles add the suffix BP to catalog numbers. Customer to supply the bolt circle drawings or template.



Type I Simplex Pole

Type I Simplex Typical Details

POLE	BUTT
18 FT.	7.73"x7.73"
23 FT.	8.54"x8.54"
28 FT.	9.35"x9.35"
30 FT.	9.68"x9.68"
33 FT.	10.16"x10.16"
38 FT.	10.98"x10.98"

- WE ARE NOT RESTRICTED TO THESE STANDARD DETAILS AND WELCOME ANY SPECIAL DESIGNS. YOU MAY USE THE STANDARD DRAWING TO MARK UP AND SEND TO YOUR SALES REPRESENTATIVE OR SEND DIRECTLY TO US.
- CABLE ENTRANCE AVAILABLE WITH CONDUIT COUPLINGS.

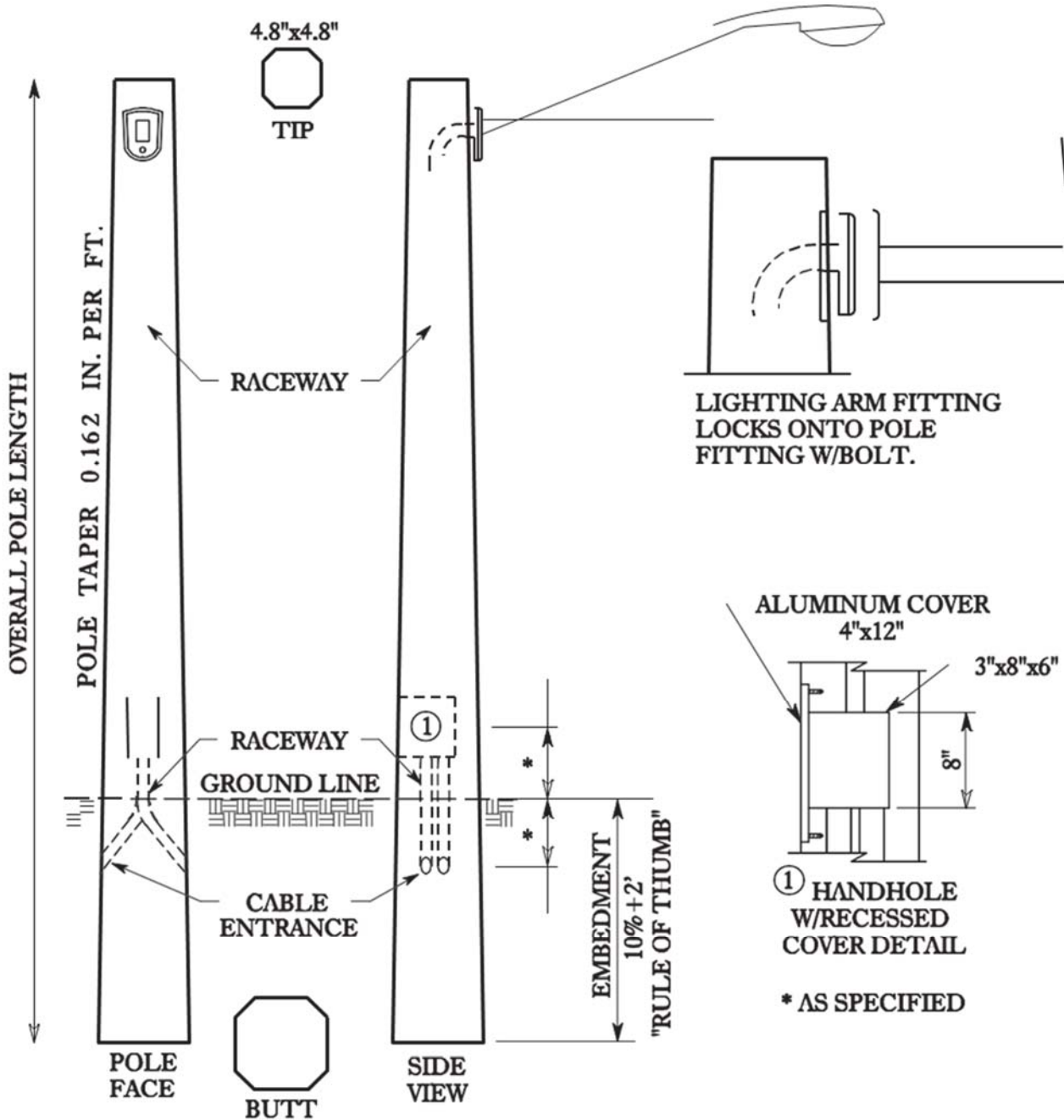



Waterford Technical Chart

Direct Embedment

CATALOG NUMBER SMOOTH GRAY	MOUNTING HEIGHT (Ft.)	POLE WEIGHT (Lbs.)	OVERALL LENGTH (Ft.)	POLE SIZE (In.)		EPA AT POLE TIP (Sq. Ft.)					ULTIMATE GROUNDLINE MOMENT (Ft. Lbs.)	BREAKING LOAD 2 Ft. FROM TIP (Lbs.)
				TIP	BUTT	90 MPH	110 MPH	130 MPH	140 MPH	160 MPH		
W10001	7.0	430	10	5.0	7.5	66	43	30	26	19	7,552	1,510
W15001	11.5	702	15.0	5.0	7.5	48	31	21	17	12	9,483	990
W20001	16.0	976	20.0	5.0	7.5	40	24	16	13	8	11,678	830

General Information

1. Different colors, finishes and exposed aggregates are available upon request.
2. Longer lengths of poles available upon request.
3. All corners are chamfered.
4. 7,000 PSI gray concrete is standard; higher strengths are available if required. The EPA's listed for poles using 7,000 psi concrete shall be reduced by 15% when decorative mixes are used.
5. STRENGTH: In most cases a higher ground line moment and a higher breaking strength and EPA can be attained without going to a larger pole.
6. EFFECTIVE PROJECTED AREA (EPA): Lonestar Prestress Mfg. concrete poles and mounting arms have been designed in accordance with accepted engineering practices to be structurally capable of withstanding wind loads and velocity pressure per ASCE 7-05. Poles to meet higher wind loads are available.
7. HOLES: Holes are precast to meet your specifications and requirements for mounting attachments, most any desired arrangement can be provided. Contact Lonestar Prestress Mfg. for any questions about field drilling light poles.
8. INSTALLATION: Lonestar Prestress Mfg. concrete poles are designed for setting directly into the ground, without the use of precast foundations, similar to the setting of wood poles. After the hole is drilled, the pole is set and plumbed, the earth is then backfilled and tamped. The depth is dependent on the nature of the soil and the anticipated load. Where it is impossible to embed the poles in the ground, such as on bridges or overpasses, a bolt-down base plate is available.
9. To specify a base plate for base mounted poles add the suffix BP to catalog numbers. Customer to supply the bolt circle drawings or template.



Waterford Pole

Waterford Typical Details

POLE	TIP
10 FT.	VARIABLE
15 FT.	VARIABLE
20 FT.	5.0"

- WE ARE NOT RESTRICTED TO THESE STANDARD DETAILS AND WELCOME ANY SPECIAL DESIGNS. YOU MAY USE THE STANDARD DRAWING TO MARK UP AND SEND TO YOUR SALES REPRESENTATIVE OR SEND DIRECTLY TO US.
- CABLE ENTRANCE AVAILABLE WITH CONDUIT COUPLINGS.

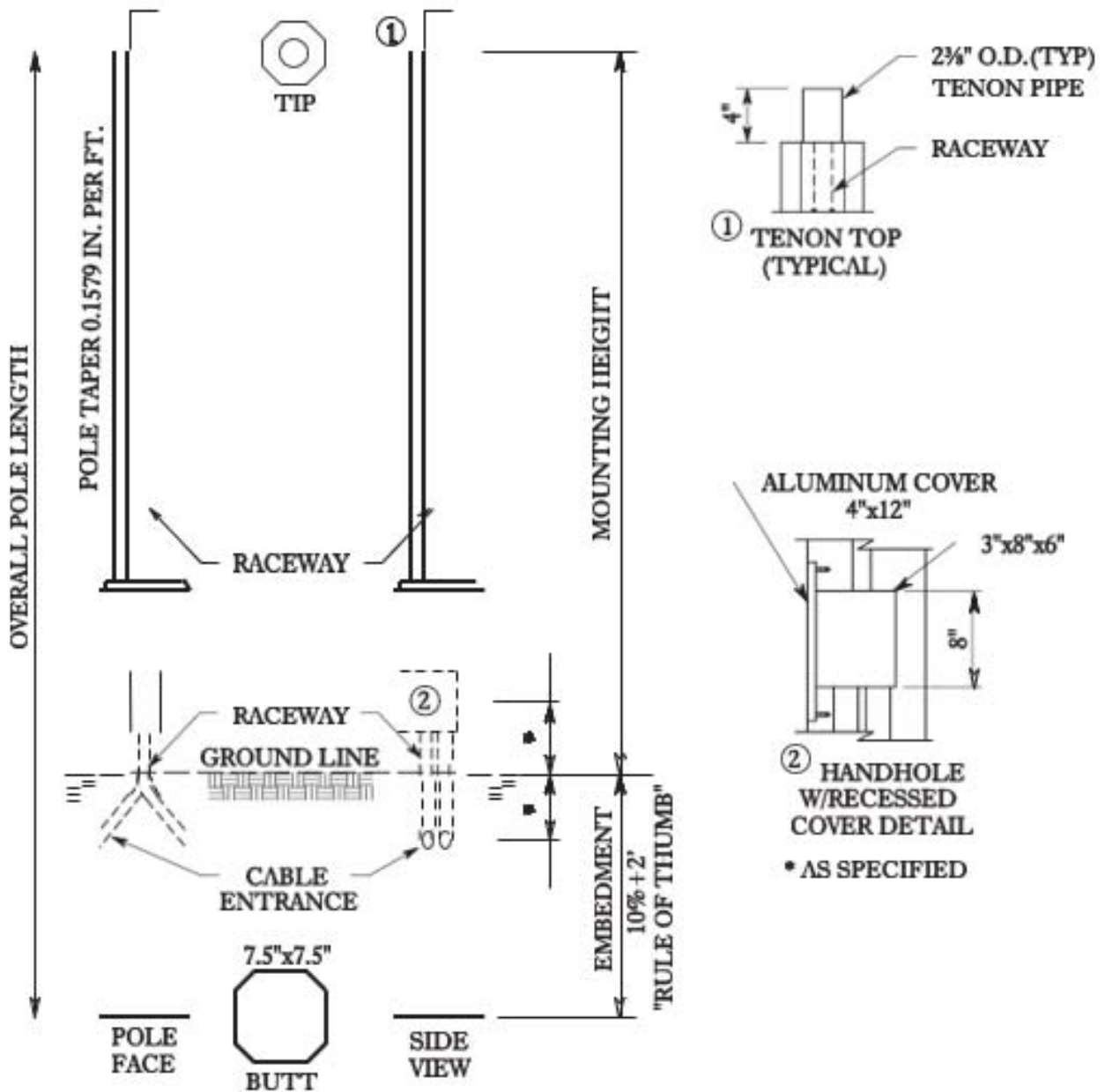

Rochester Technical Chart

Direct Embedment



CATALOG NUMBER SMOOTH GRAY	MOUNTING HEIGHT (Ft.)	POLE WEIGHT (Lbs.)	OVERALL LENGTH (Ft.)	POLE SIZE (In.)		EPA AT POLE TIP (Sq. Ft.)					ULTIMATE GROUNDLINE MOMENT (Ft. Lbs.)	BREAKING LOAD 2 Ft. FROM TIP (Lbs.)
				TIP	BUTT	90 MPH	110 MPH	130 MPH	140 MPH	160 MPH		
R10001	6.0	1170	10.0	6.2	15.6	122	81	57	49	37	11,600	2,900
R15001	11.0	1320	15.0	5.6	15.6	64	41	28	24	18	11,600	1,289
R20001	16.0	1460	20.0	5.0	15.6	41	26	17	14	10	11,600	829

General Information

1. Different colors, finishes and exposed aggregates are available upon request.
2. Longer lengths of poles available upon request.
3. All corners are chamfered.
4. 7,000 PSI gray concrete is standard; higher strengths are available if required. The EPA's listed for poles using 7,000 psi concrete shall be reduced by 15% when decorative mixes are used.
5. STRENGTH: In most cases a higher ground line moment and a higher breaking strength and EPA can be attained without going to a larger pole.
6. EFFECTIVE PROJECTED AREA (EPA): Lonestar Prestress Mfg. concrete poles and mounting arms have been designed in accordance with accepted engineering practices to be structurally capable of withstanding wind loads and velocity pressure per ASCE 7-05. Poles to meet higher wind loads are available.
7. HOLES: Holes are precast to meet your specifications and requirements for mounting attachments, most any desired arrangement can be provided. Contact Lonestar Prestress Mfg. for any questions about field drilling light poles.
8. INSTALLATION: Lonestar Prestress Mfg. concrete poles are designed for setting directly into the ground, without the use of precast foundations, similar to the setting of wood poles. After the hole is drilled, the pole is set and plumbed, the earth is then backfilled and tamped. The depth is dependent on the nature of the soil and the anticipated load. Where it is impossible to embed the poles in the ground, such as on bridges or overpasses, a bolt-down base plate is available.
9. To specify a base plate for base mounted poles add the suffix BP to catalog numbers. Customer to supply the bolt circle drawings or template.



Rochester Pole

Rochester Typical Details

POLE	TIP
10 FT.	VARIABLE
15 FT.	VARIABLE
20 FT.	5.0"

- WE ARE NOT RESTRICTED TO THESE STANDARD DETAILS AND WELCOME ANY SPECIAL DESIGNS. YOU MAY USE THE STANDARD DRAWING TO MARK UP AND SEND TO YOUR SALES REPRESENTATIVE OR SEND DIRECTLY TO US.
- CABLE ENTRANCE AVAILABLE WITH CONDUIT COUPLINGS.

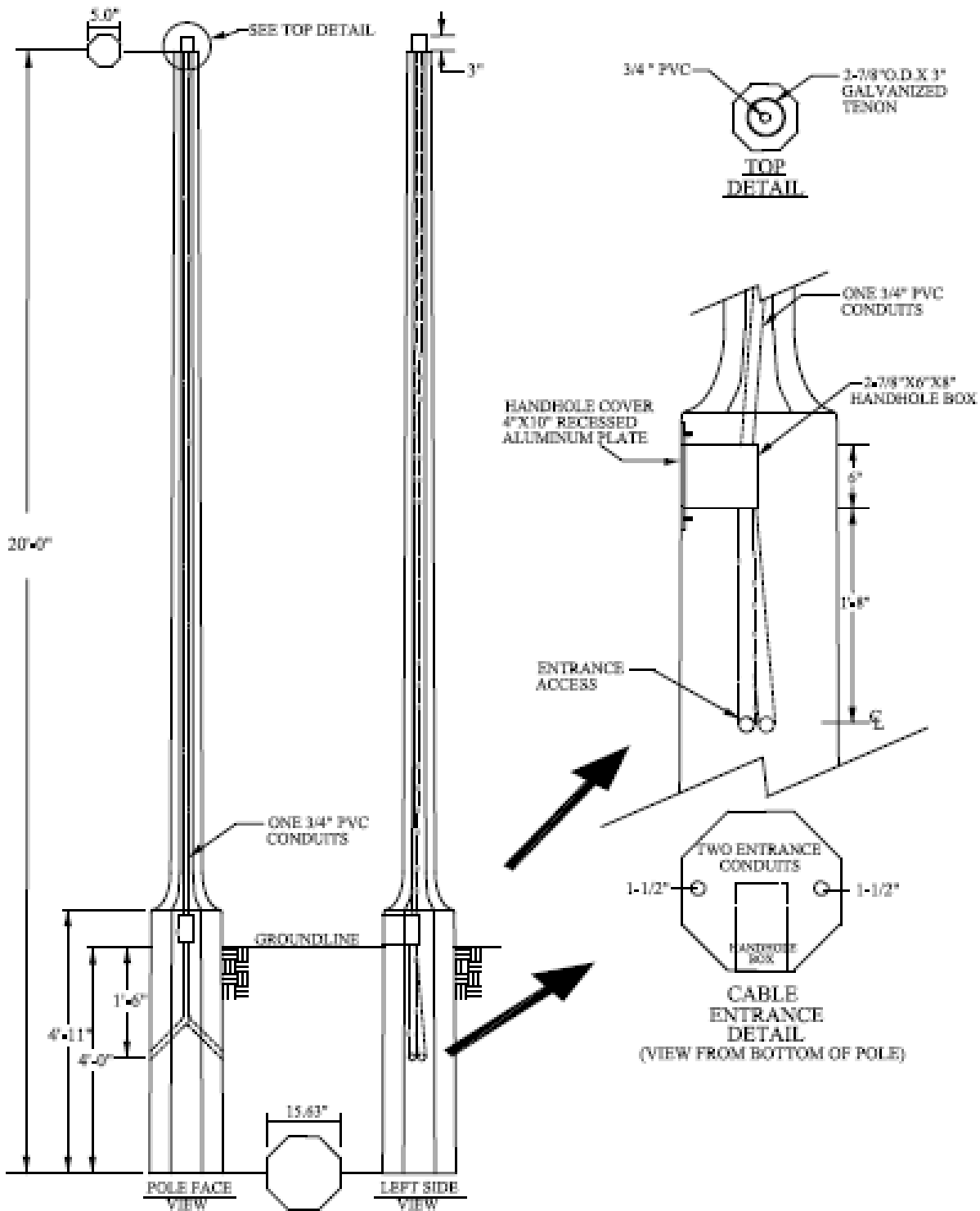

Type III Technical Chart

Used for Recreational and Industrial Lighting and Distribution

Direct Embedment

CATALOG NUMBER SMOOTH GRAY	MOUNTING HEIGHT (Ft.)	POLE WEIGHT (Lbs.)	OVERALL LENGTH (Ft.)	POLE SIZE (In.)		EPA AT POLE TIP (Sq. Ft.)					ULTIMATE GROUNDLINE MOMENT (Ft. Lbs.)	BREAKING LOAD 2 Ft. FROM TIP (Lbs.)
				TIP	BUTT	90 MPH	110 MPH	130 MPH	140 MPH	160 MPH		
253002-4	20.5	1,703	25.0	6.0	10.06	132	85	58	49	35	48,200	2,605
303002-4	25.0	2,264	30.0	6.0	10.88	121	77	52	43	31	57,700	2,508
353002-4	29.5	2,914	35.0	6.0	11.69	114	72	48	39	27	67,800	2,465
403002-4	34.0	3,660	40.0	6.0	12.50	109	68	44	36	24	78,600	2,456
453002-4	38.5	4,508	45.0	6.0	13.31	105	64	41	33	21	90,400	2,476
503002-4	43.0	5,465	50.0	6.0	14.13	102	61	38	30	18	102,500	2,500
553002-8	47.5	6,618	55.0	6.0	14.94	130	79	50	40	25	145,100	3,189
603002-8	52.0	7,820	60.0	6.0	15.75	129	78	48	38	25	163,800	3,276
653002-8	56.5	9,151	65.0	6.0	16.56	128	76	46	36	21	183,100	3,359
703002-8	61.0	10,617	70.0	6.0	17.38	126	74	44	33	18	201,800	3,420

General Information

1. Different colors, finishes and exposed aggregates are available upon request.
2. Longer lengths of poles available upon request.
3. All corners are chamfered.
4. 7,000 PSI gray concrete is standard; higher strengths are available if required. The EPA's listed for poles using 7,000 psi concrete shall be reduced by 15% when decorative mixes are used.
5. STRENGTH: In most cases a higher ground line moment and a higher breaking strength and EPA can be attained without going to a larger pole.
6. EFFECTIVE PROJECTED AREA (EPA): Lonestar Prestress Mfg. concrete poles and mounting arms have been designed in accordance with accepted engineering practices to be structurally capable of withstanding wind loads and velocity pressure per ASCE 7-05. Poles to meet higher wind loads are available.
7. HOLES: Holes are precast to meet your specifications and requirements for mounting attachments, most any desired arrangement can be provided. Contact Lonestar Prestress Mfg. for any questions about field drilling light poles.
8. INSTALLATION: Lonestar Prestress Mfg. concrete poles are designed for setting directly into the ground, without the use of precast foundations, similar to the setting of wood poles. After the hole is drilled, the pole is set and plumbed, the earth is then backfilled and tamped. The depth is dependent on the nature of the soil and the anticipated load. Where it is impossible to embed the poles in the ground, such as on bridges or overpasses, a bolt-down base plate is available.
9. To specify a base plate for base mounted poles add the suffix BP to catalog numbers. Customer to supply the bolt circle drawings or template.



Type III Pole

POLE	BUTT
25 FT.	10.06"x10.06"
30 FT.	10.88"x10.88"
35 FT.	11.69"x11.69"
40 FT.	12.50"x12.50"
45 FT.	13.31"x13.31"
50 FT.	14.13"x14.13"
55 FT.	14.94"x14.94"
60 FT.	15.75"x15.75"
65 FT.	16.56"x16.56"
70 FT.	17.38"x17.38"

Type III Typical Details

- WE ARE NOT RESTRICTED TO THESE STANDARD DETAILS AND WELCOME ANY SPECIAL DESIGNS. YOU MAY USE THE STANDARD DRAWING TO MARK UP AND SEND TO YOUR SALES REPRESENTATIVE OR SEND DIRECTLY TO US.
- CABLE ENTRANCE AVAILABLE WITH CONDUIT COUPLINGS.

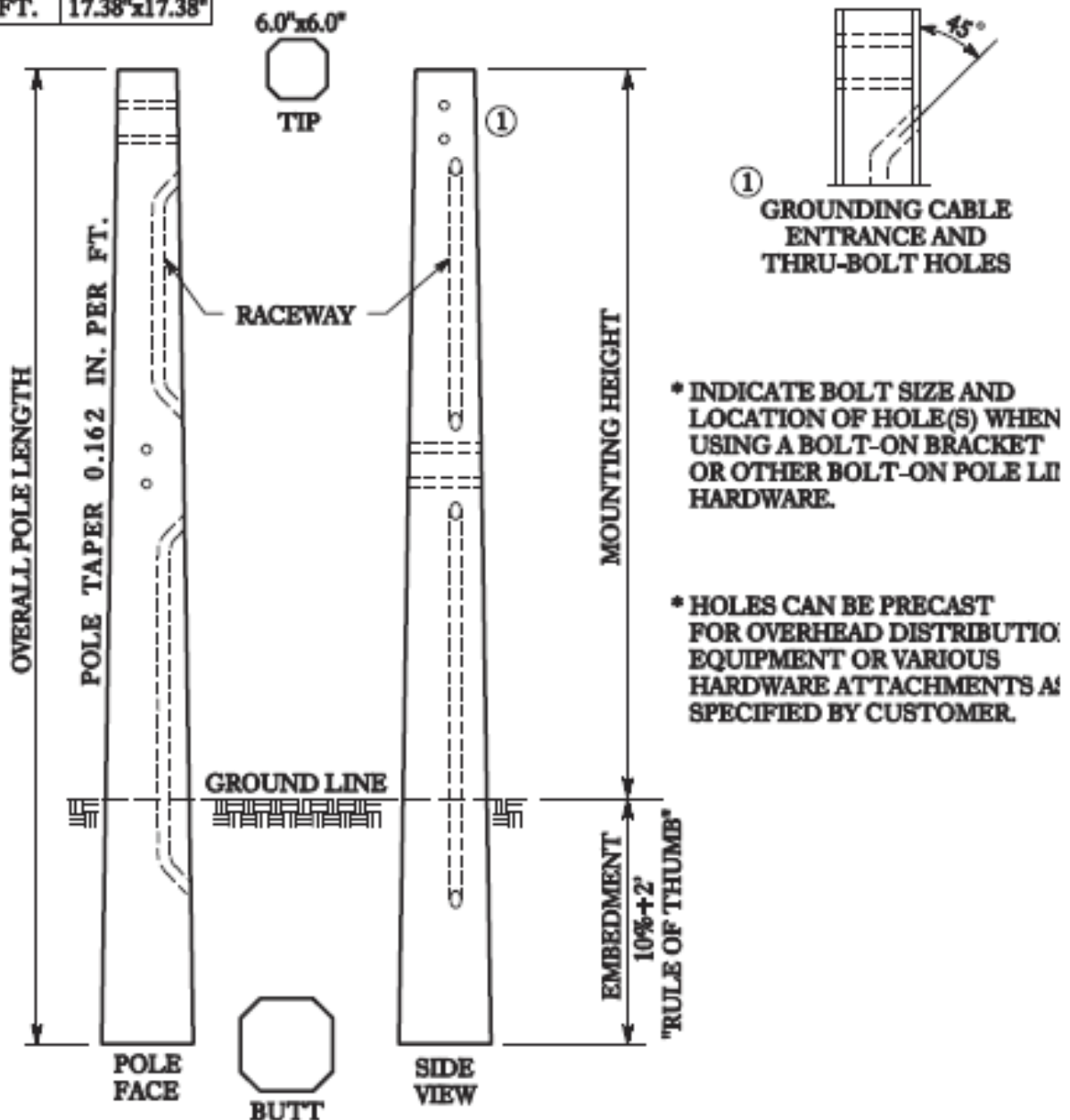

Type IV Technical Chart

Used for Power Distribution—Heavy Duty

Direct Embedment

CATALOG NUMBER SMOOTH GRAY	MOUNTING HEIGHT (Ft.)	POLE WEIGHT (Lbs.)	OVERALL LENGTH (Ft.)	POLE SIZE (In.)		EPA AT POLE TIP (Sq. Ft.)					ULTIMATE GROUND-LINE MOMENT (Ft. Lbs.)	BREAK-ING LOAD 2 Ft. FROM TIP (Lbs.)
				TIP	BUTT	90 MPH	110 MPH	130 MPH	140 MPH	160 MPH		
254002-4	20.5	2,424	25.0	7.63	11.69	194	126	87	73	54	70,200	3,794
304002-8	25.0	3,213	30.0	7.63	12.50	214	139	96	81	59	99,300	4,317
354002-8	29.5	4,068	35.0	7.63	13.31	200	129	88	73	52	115,300	4,192
404002-8	34.0	5,032	40.0	7.63	14.13	190	121	81	67	47	131,800	4,118
454002-8	38.5	6,111	45.0	7.63	14.94	182	115	76	63	43	149,400	4,093
504002-8	43.0	7,312	50.0	7.63	15.75	177	110	72	59	39	169,200	4,126
554002-8	47.5	8,642	55.0	7.63	16.56	171	106	68	55	36	188,400	4,140
604002-8	52.0	10,107	60.0	7.63	17.38	164	100	63	50	31	205,900	4,118

General Information

1. Different colors, finishes and exposed aggregates are available upon request.
2. Longer lengths of poles available upon request.
3. All corners are chamfered.
4. 7,000 PSI gray concrete is standard; higher strengths are available if required. The EPA's listed for poles using 7,000 psi concrete shall be reduced by 15% when decorative mixes are used.
5. STRENGTH: In most cases a higher ground line moment and a higher breaking strength and EPA can be attained without going to a larger pole.
6. EFFECTIVE PROJECTED AREA (EPA): Lonestar Prestress Mfg. concrete poles and mounting arms have been designed in accordance with accepted engineering practices to be structurally capable of withstanding wind loads and velocity pressure per ASCE 7-05. Poles to meet higher wind loads are available.
7. HOLES: Holes are precast to meet your specifications and requirements for mounting attachments, most any desired arrangement can be provided. Contact Lonestar Prestress Mfg. for any questions about field drilling light poles.
8. INSTALLATION: Lonestar Prestress Mfg. concrete poles are designed for setting directly into the ground, without the use of precast foundations, similar to the setting of wood poles. After the hole is drilled, the pole is set and plumbed, the earth is then backfilled and tamped. The depth is dependent on the nature of the soil and the anticipated load. Where it is impossible to embed the poles in the ground, such as on bridges or overpasses, a bolt down base plate is available.
9. To specify a base plate for base mounted poles add the suffix BP to catalog numbers. Customer to supply the bolt circle drawings or template.



Type IV Pole

POLE	BUTT
25 FT.	11.69"x11.69"
30 FT.	12.50"x12.50"
35 FT.	13.31"x13.31"
40 FT.	14.13"x14.13"
45 FT.	14.94"x14.94"
50 FT.	15.75"x15.75"
55 FT.	16.56"x16.56"
60 FT.	17.38"x17.38"

Type IV Typical Details

- WE ARE NOT RESTRICTED TO THESE STANDARD DETAILS AND WELCOME ANY SPECIAL DESIGNS. YOU MAY USE THE STANDARD DRAWING TO MARK UP AND SEND TO YOUR SALES REPRESENTATIVE OR SEND DIRECTLY TO US.
- CABLE ENTRANCE AVAILABLE WITH CONDUIT COUPLINGS.

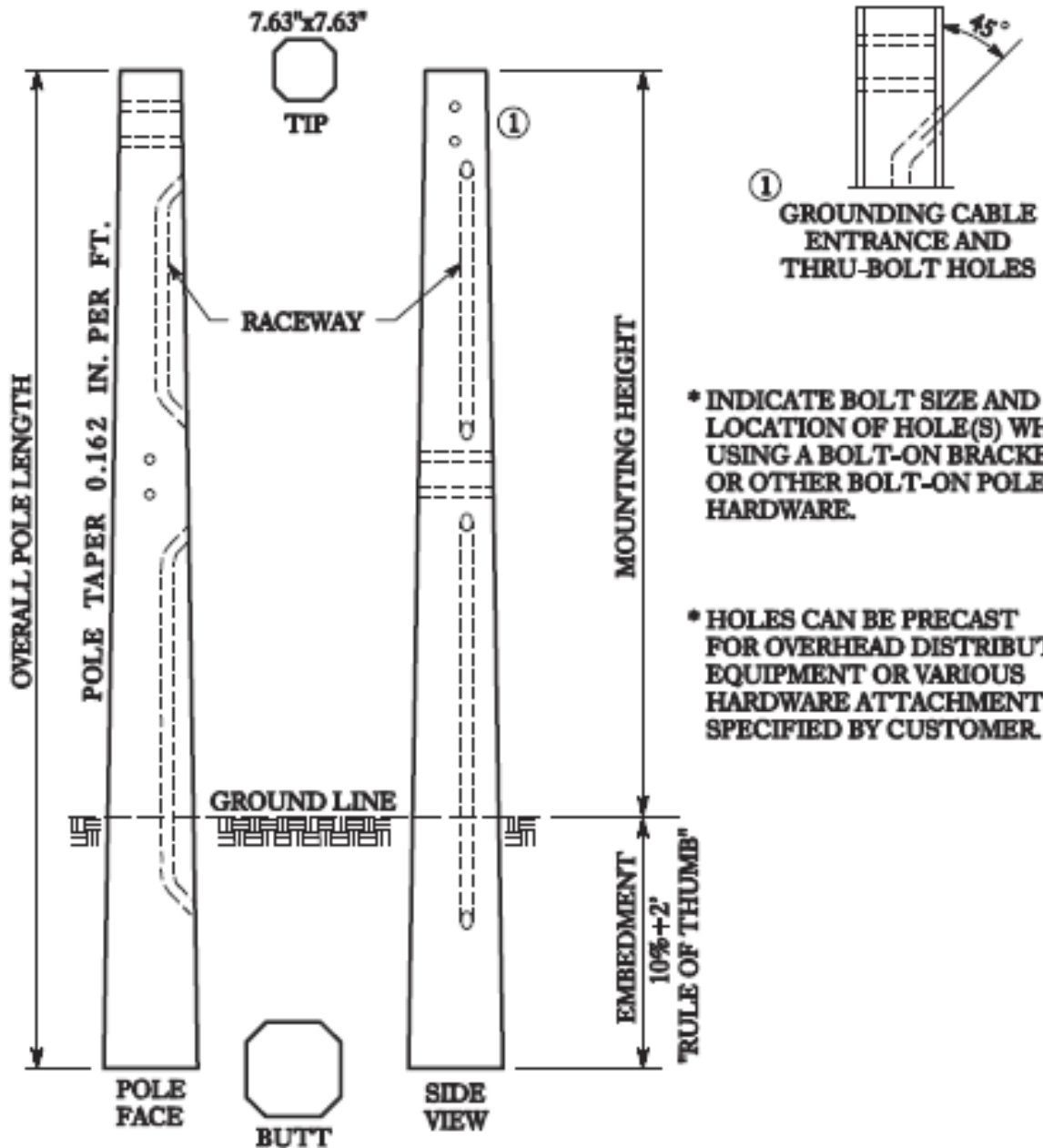

- * INDICATE BOLT SIZE AND LOCATION OF HOLE(S) WHEN USING A BOLT-ON BRACKET OR OTHER BOLT-ON POLE LIFT HARDWARE.
- * HOLES CAN BE PRECAST FOR OVERHEAD DISTRIBUTION EQUIPMENT OR VARIOUS HARDWARE ATTACHMENTS AS SPECIFIED BY CUSTOMER.

Sports Lighting Technical Chart

CATALOG NUMBER SMOOTH GRAY	MOUNT- ING HEIGHT (Ft.)	POLE WEIGHT (Lbs.)	OVERALL LENGTH (Ft.)	POLE SIZE (In.)		EPA AT POLE TIP (Sq. Ft.)					ULTIMATE GROUNDLINE MOMENT (Ft. Lbs.)
				TIP	BUTT	90 MPH	110 MPH	130 MPH	140 MPH	160 MPH	
453502-8	37	4,4574	45	6.00	13.31	134	84	55	45	31	106,100
454502-8	37	6,116	45	7.62	14.94	184	116	77	64	44	143,300
503502-8	42	5,538	50	6.00	14.13	132	82	53	43	28	124,000
504502-8	42	7,318	50	7.62	15.75	178	111	73	60	40	164,700
553502-8	46	6,618	55	6.00	14.94	130	80	51	41	26	139,200
554502-8	46	8,648	55	7.62	16.56	173	107	69	56	37	182,100
603502-8	51	7,820	60	6.00	15.75	129	78	49	39	24	159,400
604502-8	51	10,116	60	7.62	17.38	166	101	64	51	32	202,100
653502-8	55	9,151	65	6.00	16.56	129	77	47	37	22	176,900
703502-8	60	10,617	70	6.00	17.38	126	74	44	34	19	197,500

Notes:

1. EPAs shown do not include cross arm. Please refer to the Cross Arm Bracket Technical Chart for cross arm EPA.
2. Above values are based on an assumed minimum embedment of 10% of the length plus 3 feet.

Cross Arm Bracket Technical Chart

CATALOG NUMBER	TYPE	ASSEMBLY WEIGHT (Lbs.)	ANGLE EPA (Sq. Ft.)	MAXIMUM INDIVIDUAL FIXTURE SIZE	
				EPA (Sq. Ft.)	WEIGHT (Lbs.)
962839	2 LIGHT	35	1.5	3.5	75
963859	3 LIGHT	66	2.8	3.5	75
964889	4 LIGHT	78	4.0	3.5	75
9658109	5 LIGHT	155	7.5	3.5	75
9668139	6 LIGHT	175	9.3	3.5	75

Angles and bolts for cross arms to be hot dipped galvanized unless otherwise specified by customer.

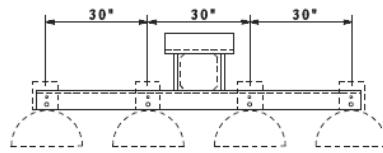

PLAN

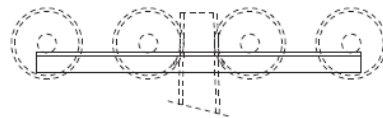

ELEVATION

TYPICAL LAYOUT FOR EVEN NUMBER OF FIXTURES. FIXTURE ARRANGEMENT TYPICAL FOR ONE OR BOTH SIDES OF POLE.

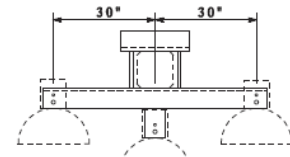

PLAN

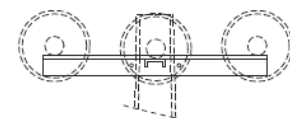

ELEVATION

TYPICAL LAYOUT FOR ODD NUMBER OF FIXTURES. FIXTURE ARRANGEMENT TYPICAL FOR ONE OR BOTH SIDES OF POLE.

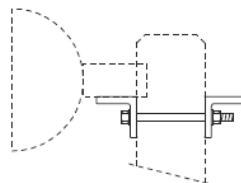

SIDE VIEW

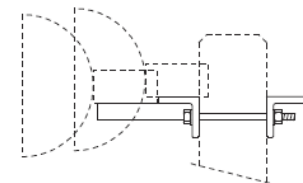

SIDE VIEW



Sports Lighting Pole

POLE	TIP	BUTT
45 FT.	6"	13.31"x13.31"
45 FT.	7.6"	14.94"x14.94"
50 FT.	6"	14.13"x14.13"
50 FT.	7.6"	15.75"x15.75"
55 FT.	6"	14.94"x14.94"
55 FT.	7.6"	16.56"x16.56"
60 FT.	6"	15.75"x15.75"
60 FT.	7.6"	17.38"x17.38"
65 FT.	6"	16.56"x16.56"
70 FT.	6"	17.38"x17.38"

Sports Lighting Typical Details

- WE ARE NOT RESTRICTED TO THESE STANDARD DETAILS AND WELCOME ANY SPECIAL DESIGNS. YOU MAY USE THE STANDARD DRAWING TO MARK UP AND SEND TO YOUR SALES REPRESENTATIVE OR SEND DIRECTLY TO US.

- CABLE ENTRANCE AVAILABLE WITH CONDUIT COUPLINGS.

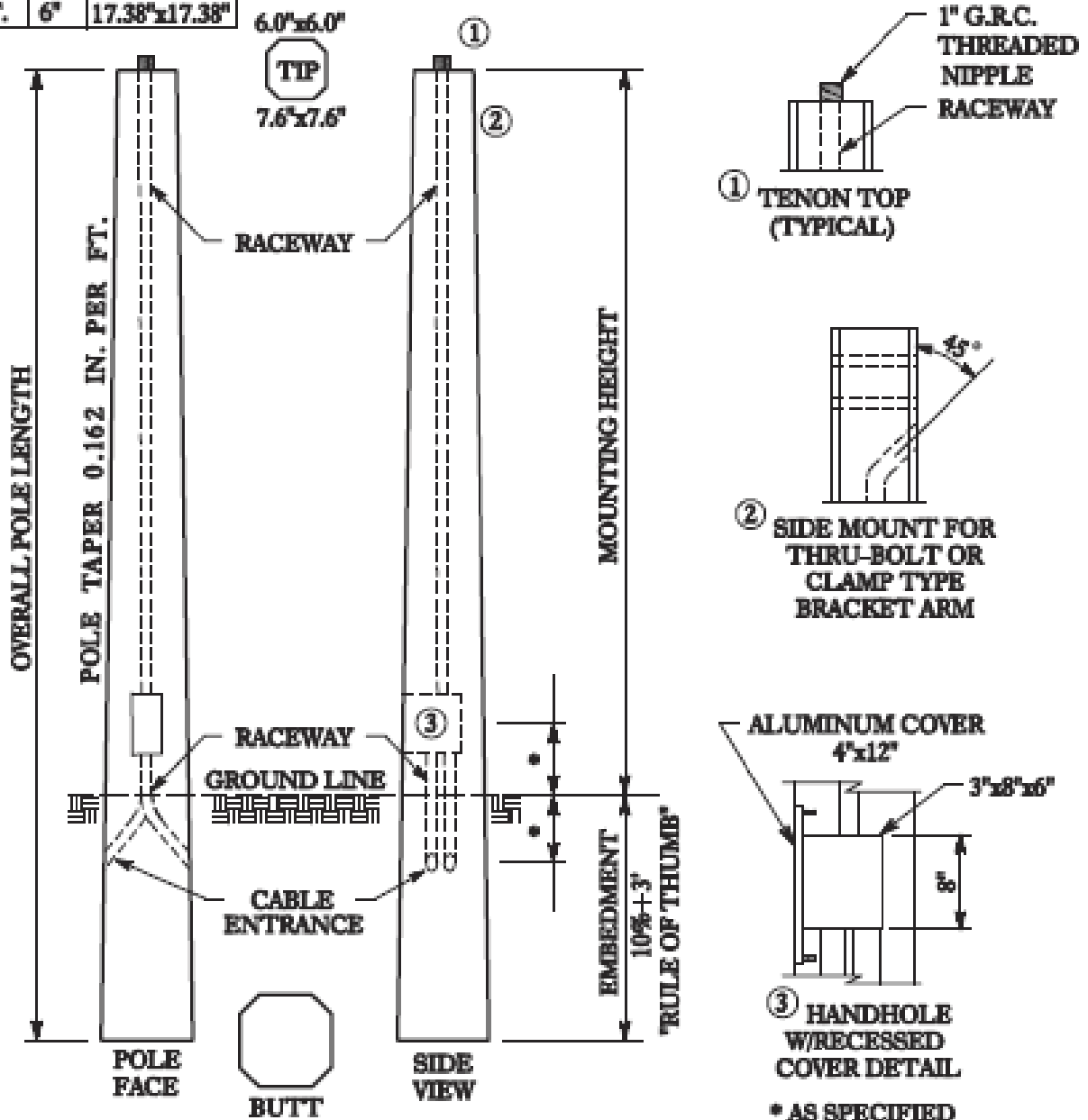

Camera Poles Technical Chart

CATALOG NUMBER SMOOTH GRAY	MOUNTING HEIGHT (Ft.)	POLE WEIGHT (Lbs.)	OVERALL LENGTH (Ft.)	POLE SIZE (in.)		EPA AT POLE TIP (Sq. Ft.)					ULTIMATE GROUND-LINE MOMENT (Ft. Lbs.)
				TIP	BUTT	90 MPH	110 MPH	130 MPH	140 MPH	160 MPH	
253602-CP	20.5	1,703	25.0	6.0	10.06	132	85	58	49	35	48,200
254602-CP	20.5	2,424	25.0	7.63	11.69	194	126	87	73	54	70,200
304602-CP	25.0	3,213	30.0	7.63	12.50	214	139	96	81	59	99,300
303602-CP	25.0	2,264	30.0	6.0	10.88	121	77	52	43	31	57,700
353602-CP	29.5	2,914	35.0	6.0	11.69	114	72	48	39	27	67,800
354602-CP	29.5	4,068	35.0	7.63	13.31	200	129	88	73	52	115,300
403602-CP	34.0	3,660	40.0	6.0	12.50	109	68	44	36	24	78,600
404602-CP	34.0	5,032	40.0	7.63	14.13	190	121	81	67	47	131,800
453602-CP	37	4,4574	45	6.00	13.31	134	84	55	45	31	106,100
454602-CP	37	6,116	45	7.62	14.94	184	116	77	64	44	143,300
503602-CP	42	5,538	50	6.00	14.13	132	82	53	43	28	124,000
504602-CP	42	7,318	50	7.62	15.75	178	111	73	60	40	164,700
553602-CP	46	6,618	55	6.00	14.94	130	80	51	41	26	139,200
554602-CP	46	8,648	55	7.62	16.56	173	107	69	56	37	182,100
603602-CP	51	7,820	60	6.00	15.75	129	78	49	39	24	159,400
604602-CP	51	10,116	60	7.62	17.38	166	101	64	51	32	202,100
653602-CP	55	9,151	65	6.00	16.56	129	77	47	37	22	176,900
703602CP	60	10,617	70	6.00	17.38	126	74	44	34	19	197,500

General Information

1. Different colors, finishes and exposed aggregates are available upon request.
2. Longer lengths of poles available upon request.
3. All corners are chamfered.
4. 7,000 PSI gray concrete is standard; higher strengths are available if required. The EPA's listed for poles using 7,000 psi concrete shall be reduced by 15% when decorative mixes are used.
5. STRENGTH: In most cases a higher ground line moment and a higher breaking strength and EPA can be attained without going to a larger pole.
6. EFFECTIVE PROJECTED AREA (EPA): Lonestar Prestress Mfg. concrete poles and mounting arms have been designed in accordance with accepted engineering practices to be structurally capable of withstanding wind loads and velocity pressure per ASCE 7-05. Poles to meet higher wind loads are available.
7. HOLES: Holes are precast to meet your specifications and requirements for mounting attachments, most any desired arrangement can be provided. Contact Lonestar Prestress Mfg. for any questions about field drilling light poles.
8. INSTALLATION: Lonestar Prestress Mfg. concrete poles are designed for setting directly into the ground, without the use of precast foundations, similar to the setting of wood poles. After the hole is drilled, the pole is set and plumbed, the earth is then backfilled and tamped. The depth is dependent on the nature of the soil and the anticipated load. Where it is impossible to embed the poles in the ground, such as on bridges or overpasses, a bolt-down base plate is available.
9. To specify a base plate for base mounted poles add the suffix BP to catalog numbers. Customer to supply the bolt circle drawings or template.



The Solid Alternative to Wood

Lonestar Prestress Mfg., Inc. concrete poles were developed to meet the expanding need of a supporting structure for street, highway and area lighting, athletic lighting, signs, overhead power distribution, and power transmission, as well as power substations and traffic signals.

50+ Year Service Life

Lonestar prestressed concrete poles are safe for the environment, require no maintenance and have a life of fifty (50) or more years.

High Quality

Every Lonestar pole is an engineered product designed for each specific application and produced under rigid standards of quality.

No Maintenance

Lonestar prestressed concrete poles require no painting, will not rust, are impervious to sunlight (ultraviolet radiation), chemicals (fertilizers, oils, etc.), animals and insects (woodpeckers, termites, etc.) and do not require ground-line treating.

High Strength

Lonestar prestress concrete poles are classified by their ultimate capacity to sustain a horizontal load applied at a point two feet below the tip. Lonestar's concrete is a special high-strength mix design put into compression by prestressed ASTM 416 high strength steel strands.

Many Accessories Offered

Lonestar offers a complete line of brackets, pole caps, pole tenons, and other attachments to allow a complete installation.

Special Modifications

Special needs such as internal grounding, pole steps and cages, floodlight attachments, and other attachments are our specialty. For additional information, or to discuss your special requirements, please contact our sales department.

Accurate Information

The information contained in this catalog is accurate to the best of our knowledge. All products are designed strictly for specific applications. It is the sole responsibility of the buyer to determine the suitability of the products for any other contemplated use. If the products are used for any application other than those specified, Lonestar Prestress Mfg., Inc. will not be liable for any injury or damage arising from their use.



Utility Pole Direct Embedment 25-45 Feet



Utility 25-45 Feet Technical Chart Grade B Construction

Used for Recreational and Industrial Lighting Distribution

Direct Embedment

CATALOG NUMBER	POLE LENGTH (Ft.)	CONCRETE POLE CLASS	POLE WEIGHT (Lbs.)	HT. ABOVE GRADE (Ft.)	POLE SIZE (In.)		ANSI GROUNDLINE MOMENT (Ft. Lbs.) *	ULTIMATE GROUNDLINE MOMENT (Ft. Lbs.) **
					TIP	BUTT		
251302-4	25	5-C	963	20.5	4.00	8.06	22,220	23,750
253302-0	25	4-C	1,667	20.5	6.00	10.06	27,750	38,250
253302-0	25	3-C	1,667	20.5	6.00	10.06	35,150	38,250
253302-4	25	2-C	1,703	20.5	6.00	10.06	44,400	48,250
253302-8	25	1-C	1,740	20.5	6.00	10.06	55,500	56,080
254302-4	25	H1-C	2,424	20.5	7.63	11.69	68,450	70,160
254302-8	25	H2-C	2,464	20.5	7.63	11.69	83,250	85,080
301302-4	30	5-C	1,327	25.0	4.00	8.88	27,600	29,330
303302-0	30	4-C	2,220	25.0	6.00	10.88	34,500	43,160
303302-4	30	3-C	2,264	25.0	6.00	10.88	43,700	57,750
303302-4	30	2-C	2,264	25.0	6.00	10.88	55,200	57,750
303302-8	30	1-C	2,308	25.0	6.00	10.88	69,000	69,000
304302-8	30	H1-C	3,213	25.0	7.63	12.50	85,100	99,330
305302-4	30	H2-C	4,066	25.0	9.00	13.88	103,500	105,410
351302-4	35	5-C	1,763	29.5	4.00	9.69	33,000	35,250
353302-0	35	4-C	2,863	29.5	6.00	11.69	41,250	48,000
353302-4	35	3-C	2,914	29.5	6.00	11.69	52,250	67,830
353302-4	35	2-C	2,914	29.5	6.00	11.69	66,000	67,830
353302-8	35	1-C	2,966	29.5	6.00	11.69	82,500	82,500
354302-8	35	H1-C	4,068	29.5	7.63	13.31	101,750	115,410
355302-8	35	H2-C	5,153	29.5	9.00	14.69	123,750	150,160
401302-4	40	5-C	2,279	34.0	4.00	10.50	38,400	41,580
403302-0	40	4-C	3,601	34.0	6.00	12.50	48,000	53,000
403302-4	40	3-C	3,660	34.0	6.00	12.50	60,800	78,580
403302-4	40	2-C	3,660	34.0	6.00	12.50	76,800	78,580
403302-8	40	1-C	3,719	34.0	6.00	12.50	96,000	96,000
404302-8	40	H1-C	5,032	34.0	7.63	14.13	118,400	131,910
405302-8	40	H2-C	6,317	34.0	9.00	15.50	144,000	168,910
453302-0	45	5-C	4,442	38.5	6.00	13.31	43,800	57,750
453302-0	45	4-C	4,442	38.5	6.00	13.31	54,750	57,750
453302-4	45	3-C	4,508	38.5	6.00	13.31	69,350	90,410
453302-4	45	2-C	4,508	38.5	6.00	13.31	87,600	90,410
453302-8	45	1-C	4,574	38.5	6.00	13.31	109,500	111,330
454302-8	45	H1-C	6,111	38.5	7.63	14.94	135,050	149,500
455302-8	45	H2-C	7,607	38.5	9.00	16.31	164,250	187,580

* The ultimate groundline moment shown corresponds to the equivalent ANSI pole class load for concrete poles. The moments shown are not necessarily the maximum ultimate groundline moment for that particular pole.

** Ultimate groundline moment for the particular pole.

Utility 50-70 Feet Technical Chart Grade B Construction

Used for Recreational and Industrial Lighting Distribution

Direct Embedment

CATALOG NUMBER	POLE LENGTH (Ft.)	CONCRETE POLE CLASS	POLE WEIGHT (Lbs.)	HT. ABOVE GRADE (Ft.)	POLE SIZE (In.)		ANSI GROUNDLINE MOMENT (Ft. Lbs.) *	ULTIMATE GROUNDLINE MOMENT (Ft. Lbs.) **
					TIP	BUTT		
503302-0	50	5-C	5,392	43.0	6.00	14.13	49,200	62,580
503302-0	50	4-C	5,392	43.0	6.00	14.13	61,500	62,580
503302-4	50	3-C	5,465	43.0	6.00	14.13	77,900	102,580
503302-4	50	2-C	5,465	43.0	6.00	14.13	98,400	102,580
503302-8	50	1-C	5,538	43.0	6.00	14.13	123,000	127,830
504302-8	50	H1-C	7,312	43.0	7.63	15.75	151,700	169,330
505302-8	50	H2-C	9,031	43.0	9.00	17.13	184,500	205,830
553302-0	55	5-C	6,457	47.5	6.00	14.94	54,600	67,410
553302-4	55	4-C	6,537	47.5	6.00	14.94	68,250	115,000
553302-4	55	3-C	6,537	47.5	6.00	14.94	86,450	115,000
553302-4	55	2-C	6,537	47.5	6.00	14.94	109,200	115,000
553302-8	55	1-C	6,618	47.5	6.00	14.94	136,500	145,250
554302-8	55	H1-C	8,642	47.5	7.63	16.56	168,350	188,500
603302-0	60	5-C	7,644	52.0	6.00	15.75	60,000	72,250
603302-4	60	4-C	7,732	52.0	6.00	15.75	75,000	127,000
603302-4	60	3-C	7,732	52.0	6.00	15.75	95,000	127,000
603302-4	60	2-C	7,732	52.0	6.00	15.75	120,000	127,000
603302-8	60	1-C	7,820	52.0	6.00	15.75	150,000	163,830
604302-8	60	H1-C	10,107	52.0	7.63	17.38	185,000	206,000
653302-4	65	5-C	9,055	56.5	6.00	16.56	65,400	137,910
653302-4	65	4-C	9,055	56.5	6.00	16.56	81,750	137,910
653302-4	65	3-C	9,055	56.5	6.00	16.56	103,550	137,910
653302-4	65	2-C	9,055	56.5	6.00	16.56	130,800	137,910
653302-8	65	1-C	9,151	56.5	6.00	16.56	163,500	183,080
703302-4	70	5-C	10,514	61.0	6.00	17.38	70,800	147,750
703302-4	70	4-C	10,514	61.0	6.00	17.38	88,500	147,750
703302-4	70	3-C	10,514	61.0	6.00	17.38	112,100	147,750
703302-4	70	2-C	10,514	61.0	6.00	17.38	141,600	147,750
703302-8	70	1-C	10,617	61.0	6.00	17.38	177,000	201,830



* The ultimate groundline moment shown corresponds to the equivalent ANSI pole class load for concrete poles. The moments shown are not necessarily the maximum ultimate groundline moment for that particular pole.

** Ultimate groundline moment for the particular pole.

Prestressed Concrete Utility Poles

Engineering Standards: Concrete vs. Wood

Because wood deteriorates over time, the American National Standards Institute (ANSI) and the National Electrical Safety Code (NESC) require wood poles to have an initial load factor 60% greater than equivalent concrete poles.

WOOD POLE EQUIVALENCY

Traditionally, designers have specified wood poles for use as utility structures according to the pole class system set forth in the American National Standards Institutes' specifications ANSI 05.1., *Specifications and Dimensions for Wood Poles*. In order to remain consistent with the pole class system for utility structures, we have developed a wood pole equivalency (WPE) system for our prestressed concrete poles. Our WPE system is based on criteria contained in ANSI 05.1 and the National Electric Safety Code (NESC), ANSI C2.

When establishing WPE criteria, the difference between the two structural systems (materials) must be considered:

WOOD: *NESC requires an overload capacity factor (OCF) of 4.0*

Wood poles are composed of a naturally grown, biological material, which exhibits inconsistent material properties throughout the length of the pole. These inconsistencies, which have a direct impact on strength, are knots, checks, shakes and splits.

Wood poles are susceptible to rot and decay over the design life of the structure. The wood pole has less strength at the end of its service life than when it was originally placed in service.

Wood poles are susceptible to insect and animal attack. The effects of termite and woodpecker attack can significantly decrease the load carrying capacity of the wood pole well before the end of the anticipated service life.

PRESTRESSED CONCRETE: *NESC overload capacity factor (OCF) of 2.5*

Prestressed concrete poles are fabricated from engineered materials. The prestressed concrete poles have consistent material properties throughout their length.

Prestressed concrete poles are not susceptible to rot and decay. The prestressed concrete pole has the same strength throughout its service life.

Prestressed concrete poles are not susceptible to insect and animal attack.

Wood pole classes are determined by the strength require at the groundline to resist a transverse ultimate load placed 2 ft. below the tip of the pole. Each length of pole within a pole class can resist the same load placed 2 ft. from the top.

When designing pole structures for transverse wind loading, the NESC requires an overload capacity factor (OCF) of 4.0 for wood poles and 2.5 for concrete poles when determining ultimate loads (Grade B construction). Due to the above mentioned differences in the structural systems, the NESC requires the wood pole to have a strength that is 60% higher than the prestressed concrete pole. Therefore, the prestressed concrete pole can be designed for a load that is 62.5% ($2.5/4.0$) of the wood pole load and attain the same strength for the specific pole class throughout the life of the structure.

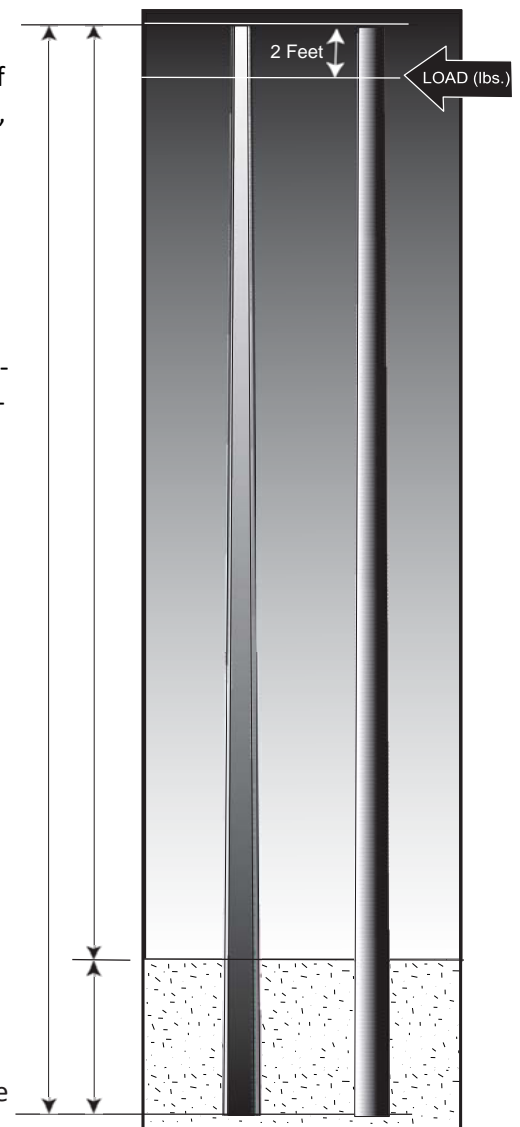

WOOD POLE EQUIVALENCY EXPLAINED

In order to simplify our WPE system we chose to use the ultimate pole top load that is two load classes lower than the wood pole. For example, ANSI 05.1 lists an ultimate pole top load of 4,500 lbs. for a Class 1 wood pole. Our concrete Class 1-C pole is designed for a 3000 lbs. (Class 3 wood pole load) ultimate pole top load. The ratio of the loads is $3000/4500=0.666$, which is in excess of $2.5/4.0=0.625$ using NESC overload capacity factors for transverse wind.

CONCRETE POLE CLASS LOADS		
CONCRETE POLE CLASS	LOAD 2 FT FROM TIP (LBS)	CONCRETE LOAD WOOD LOAD
H2-C	4,500	0.703
H1-C	3,700	0.685
1-C	3,000	0.666
2-C	2,400	0.649
3-C	1,900	0.633
4-C	1,500	0.625
5-C	1,200	0.632

The above wood pole equivalency system is based on the following assumption:

1. Transverse wind is the controlling design lead.
2. The load acts perpendicular to the face of the pole.

When design configurations involve the use of angle poles and dead end poles where other than transverse winds control the design, our technical staff should be consulted.

Prestressed Concrete Utility Poles

WOOD POLE EQUIVALENCY EXAMPLE

Example:

The following example is for the purpose of demonstrating our WPE system only. In actual design cases, loads other than transverse wind may control and must be investigated.

Assumptions:

- Tangent pole
- Equal conductor spans on both sides of poles
- Transverse wind creates controlling load case for selection of pole
- For simplicity, the wind pressure on the pole is neglected in this example but should be added to the ground line moment for actual design.
- NESC overload capacity factors: 4.0 for wood poles
2.5 for prestressed concrete poles
- Wind load on conductors produce a resultant load of 1125 lbs., 2 ft down from the top of the pole.

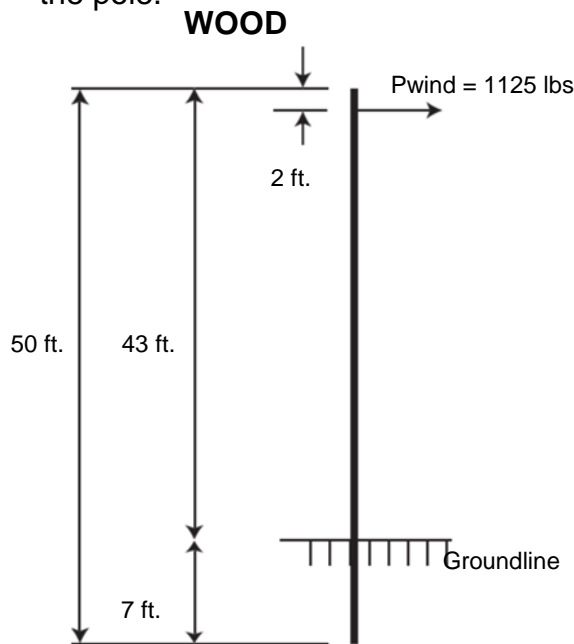

$P_u = 4.0 (1125 \text{ lbs.}) = 4500 \text{ lbs}$
 For ANSI Class 1 wood pole:
 $P_{max} = 4500 \text{ lbs.}$

$P_u = 2.5 (1125 \text{ lbs.}) = 2813 \text{ lbs.}$
 For ANSI Class 1-C prestressed concrete pole:
 $P_{max} = 3000 \text{ lbs. (Class 3 wood pole load)}$

The concrete Class 1-C pole is more than adequate for the transverse wind load. Note the max load of 3000 lbs. for the prestressed concrete pole is the same as for a Class 3 ANSI wood pole.

Standard Pole Finishes

1. The Woodlands—Brown Cement, Brown and Green Exposed Aggregate
2. Natural Gray Concrete
3. First Colony—Buff Cement with Limestone Exposed Aggregate
4. Etched White—White Cement Etched Finish
5. TWB—The Woodlands Black
6. San Jacinto Brown—Brown Cement, Pea Gravel Exposed Aggregate
7. San Jacinto Gray—Gray Cement, Pea Gravel Exposed Aggregate
8. Black and White Terrazzo
9. Pink Granite - not shown, refer to pole finish brochure.



SINGLE ARM BRACKET

966947

Four Foot Reach

Arm Dimensions:
A=44", B=36", C=19.5"

966957

Five Foot Reach

Arm Dimensions:
A=56", B=48", C=20"

966967

Six Foot Reach

Arm Dimensions:
A=68.5", B=60", C=20.5"

966977

Seven Foot Reach

Arm Dimensions:
A=80.5", B=72", C=20.5"

DOUBLE ARM BRACKET

967904

Four Foot Reach

Arm Dimensions:
A=44", B=36", C=19.5"

967905

Five Foot Reach

Arm Dimensions:
A=56", B=48", C=20"

967906

Six Foot Reach

Arm Dimensions:
A=68.5", B=60", C=20.5"

967907

Seven Foot Reach

Arm Dimensions:
A=80.5", B=72", C=20.5"

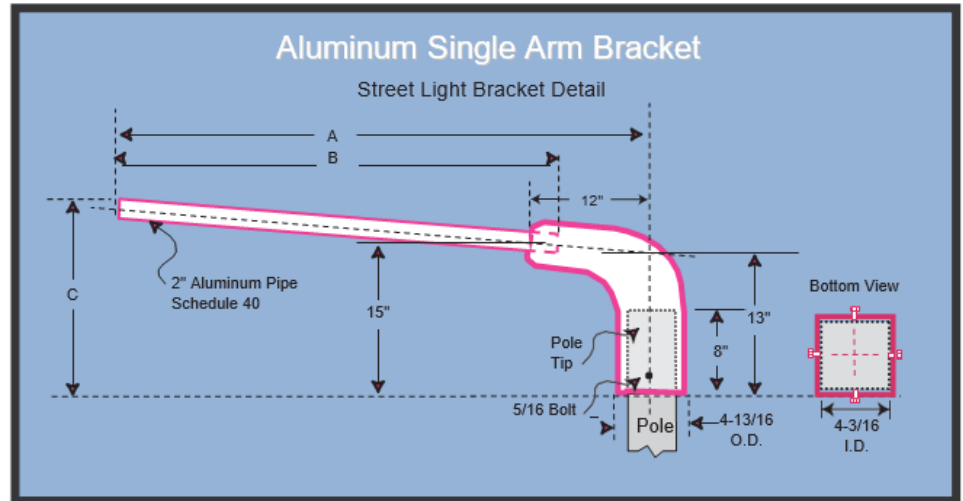

Bracket Specifications: Four, Five, Six & Seven Foot Reach

The complete bracket assembly has a uniform finish, and extends (A") from the center of the pole. The cast aluminum arm bracket is an aluminum alloy; #356-T6 Tenzoloy. Support arm is two inch, IPS aluminum pipe, ASA schedule #40, U.S. Aluminum Association #6063-T6.

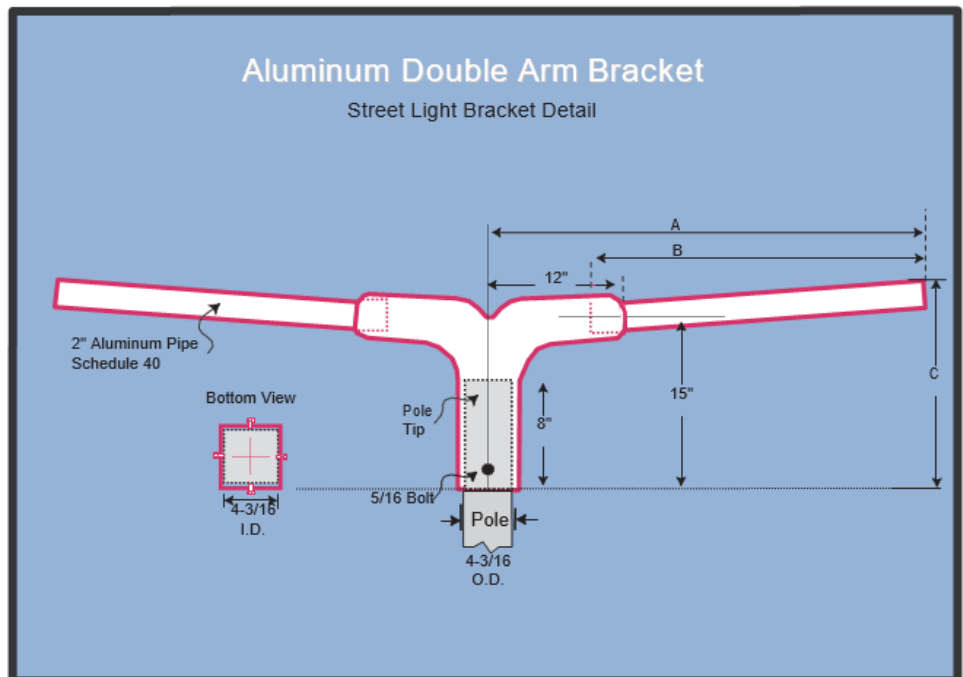

BRACKETS

SINGLE ARM BRACKET

966894

Four Foot Reach

Arm Dimension:
A=44"

966895

Five Foot Reach

Arm Dimension:
A=56"

966896

Six Foot Reach

Arm Dimension:
A=68.5"

966897

Seven Foot Reach

Arm Dimension:
A=80.5"

DOUBLE ARM BRACKET

968984

Four Foot Reach

Arm Dimension:
A=44" each side

968985

Five Foot Reach

Arm Dimension:
A=56" each side

968986

Six Foot Reach

Arm Dimension:
A=68.5" each side

968987

Seven Foot Reach

Arm Dimension:
A=80.5" each side

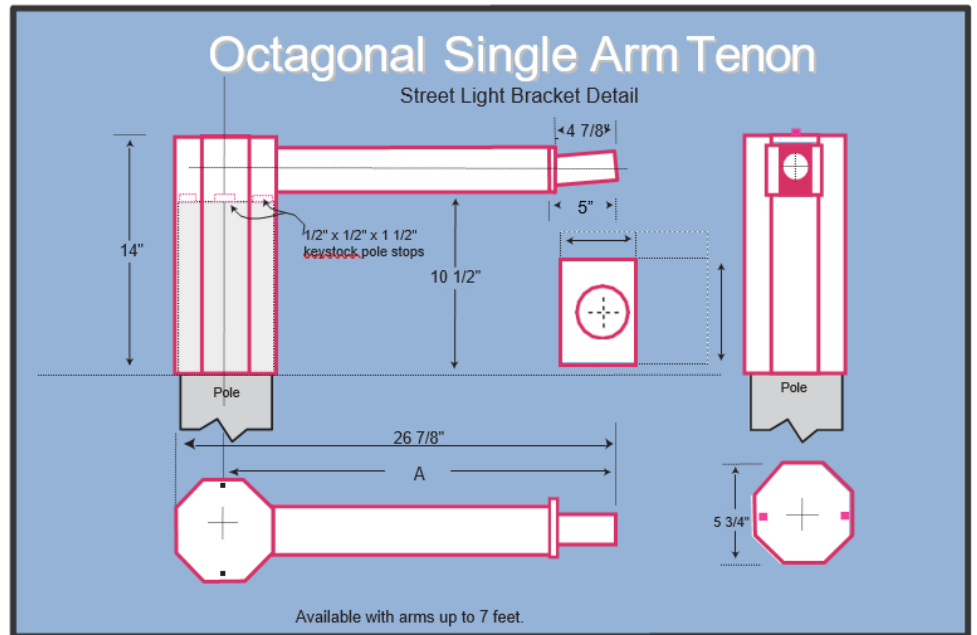

Bracket Specifications: Four, Five, Six & Seven Foot Reach

The complete bracket assembly has a uniform finish, and extends (A") from the center of the pole. The cast aluminum arm bracket is an aluminum alloy; #356-T6 Tenzoloy. Support arm is two inch, IPS aluminum pipe, ASA schedule #40, U.S. Aluminum Association #6063-T6.

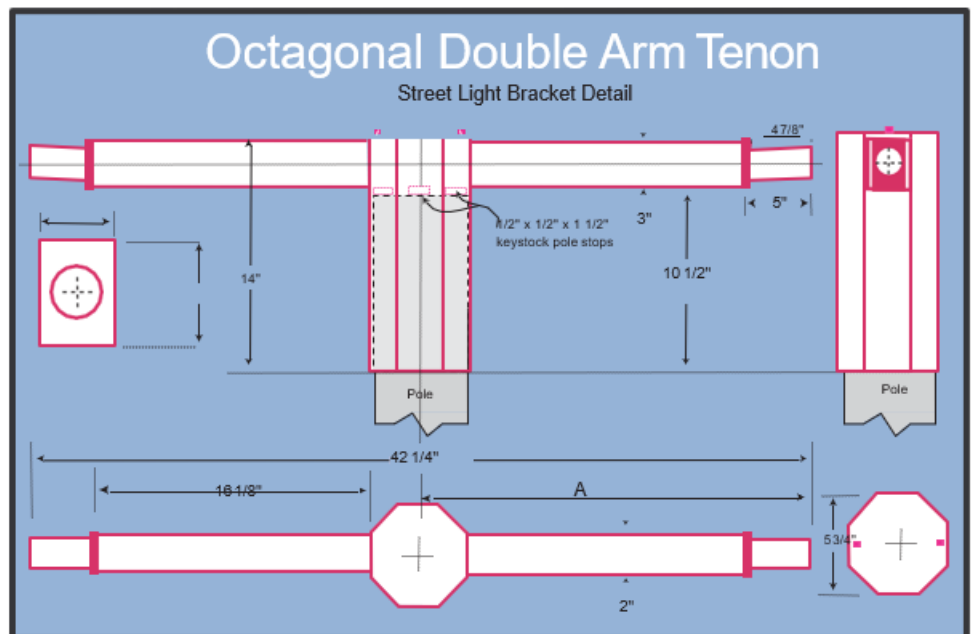

TRIPLE TENON BULLHORN

962879
TYPE I

962879
TYPE II & III

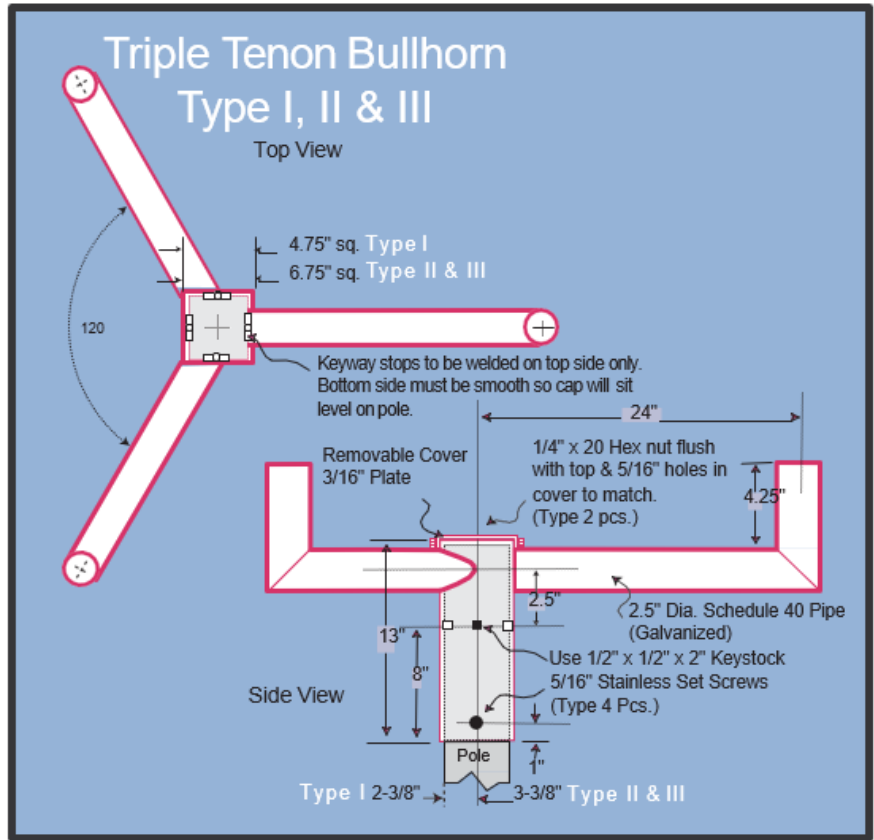

QUAD TENON BULLHORN

971879
TYPE I

979879
TYPE II & III

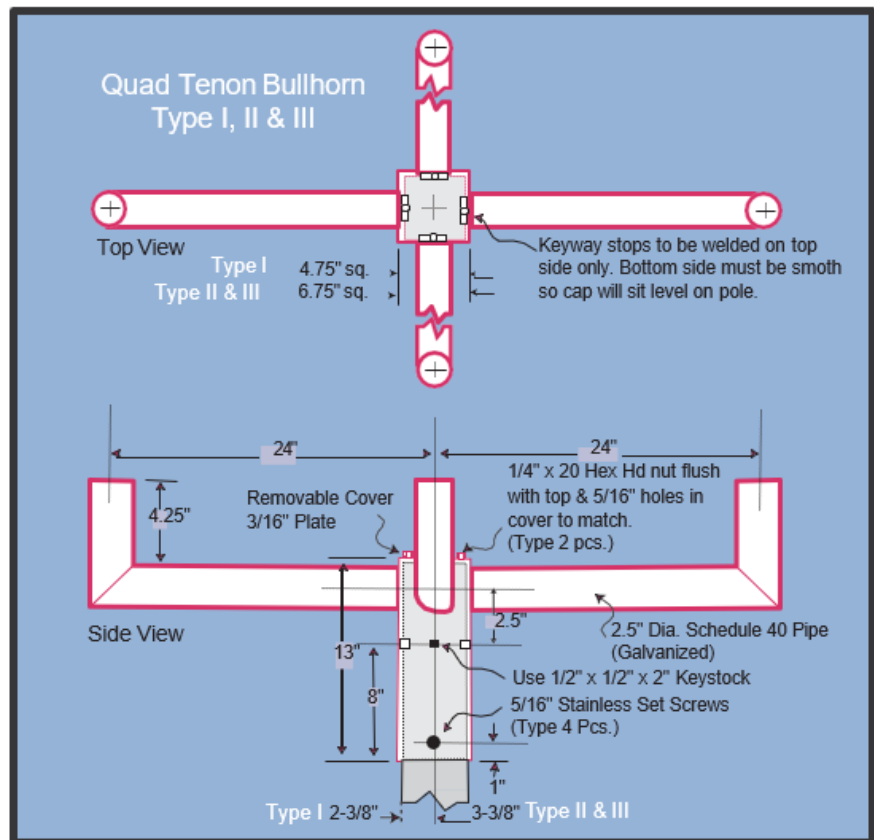

In addition to prestressed concrete poles, we also manufacture
Precast Concrete Buildings
in a variety of sizes and finishes.
For more information contact our
sales department at:
sales@lonestarprestress.com



 **Lonestar
Prestress
Manufacturing Inc.**

8892 Highway 159 East
Bellville, Texas 77418
Office: 713-896-0994 | Fax: 713-896-0762