

Type I Technical Chart

Used for Street Lighting, Parking Lot and Security Lighting,
Recreational and Industrial Lighting



Direct Embedment

| CATALOG NUMBER SMOOTH GRAY | MOUNTING HEIGHT (Ft.) | POLE WEIGHT (Lbs.) | OVERALL LENGTH (Ft.) | POLE SIZE (In.) | | EPA AT POLE TIP (Sq. Ft.) | | | | | ULTIMATE GROUNDLINE MOMENT (Ft. Lbs.) | BREAKING LOAD 2 Ft. FROM TIP (Lbs.) |
|-------------------------------|-----------------------|--------------------|----------------------|-----------------|-------|---------------------------|---------|---------|---------|---------|---------------------------------------|-------------------------------------|
| | | | | TIP | BUTT | 90 MPH | 110 MPH | 130 MPH | 140 MPH | 160 MPH | | |
| 151002 | 11.5 | 414 | 15.0 | 4.0 | 6.44 | 58 | 38 | 26 | 22 | 16 | 11,100 | 1,168 |
| 201002 | 16.0 | 649 | 20.0 | 4.0 | 7.25 | 51 | 32 | 22 | 18 | 13 | 14,400 | 1,028 |
| 251002 | 20.5 | 942 | 25.0 | 4.0 | 8.06 | 44 | 27 | 17 | 14 | 9 | 17,300 | 935 |
| 301002 | 25.0 | 1,302 | 30.0 | 4.0 | 8.88 | 37 | 22 | 13 | 10 | 6 | 19,800 | 861 |
| 351002 | 29.5 | 1,735 | 35.0 | 4.0 | 9.69 | 32 | 18 | 10 | 7 | 3 | 22,300 | 811 |
| 401002 | 34.0 | 2,246 | 40.0 | 4.0 | 10.50 | 28 | 15 | 7 | 5 | 1 | 24,800 | 775 |

General Information

1. Different colors, finishes and exposed aggregates are available upon request.
2. Longer lengths of poles available upon request.
3. All corners are chamfered.
4. 7,000 PSI gray concrete is standard; higher strengths are available if required. The EPA's listed for poles using 7,000 psi concrete shall be reduced by 15% when decorative mixes are used.
5. STRENGTH: In most cases a higher ground line moment and a higher breaking strength and EPA can be attained without going to a larger pole.
6. EFFECTIVE PROJECTED AREA (EPA): Lonestar Prestress Mfg. concrete poles and mounting arms have been designed in accordance with accepted engineering practices to be structurally capable of withstanding wind loads and velocity pressure per ASCE 7-05. Poles to meet higher wind loads are available.
7. HOLES: Holes are precast to meet your specifications and requirements for mounting attachments, most any desired arrangement can be provided. Contact Lonestar Prestress Mfg. for any questions about field drilling light poles.
8. INSTALLATION: Lonestar Prestress Mfg. concrete poles are designed for setting directly into the ground, without the use of precast foundations, similar to the setting of wood poles. After the hole is drilled, the pole is set and plumbed, the earth is then backfilled and tamped. The depth is dependent on the nature of the soil and the anticipated load. Where it is impossible to embed the poles in the ground, such as on bridges or overpasses, a bolt-down base plate is available.
9. To specify a base plate for base mounted poles add the suffix BP to catalog numbers. Customer to supply the bolt circle drawings or template.



STOCK CODE:
DISTRIBUTOR:



8892 Hwy 159 E
Bellville, TX 77418
www.lonestarprestress.com
Tel: (713) 896-0994
Fax: (713) 896-0762

DWG. NO: _____ REV: _____
CAT. NO: 151002 DATE: 7/10/14
PROJECT: _____

APPROVED BY: _____ DATE: _____

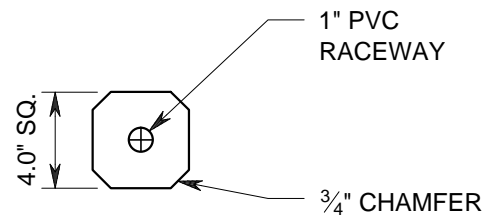
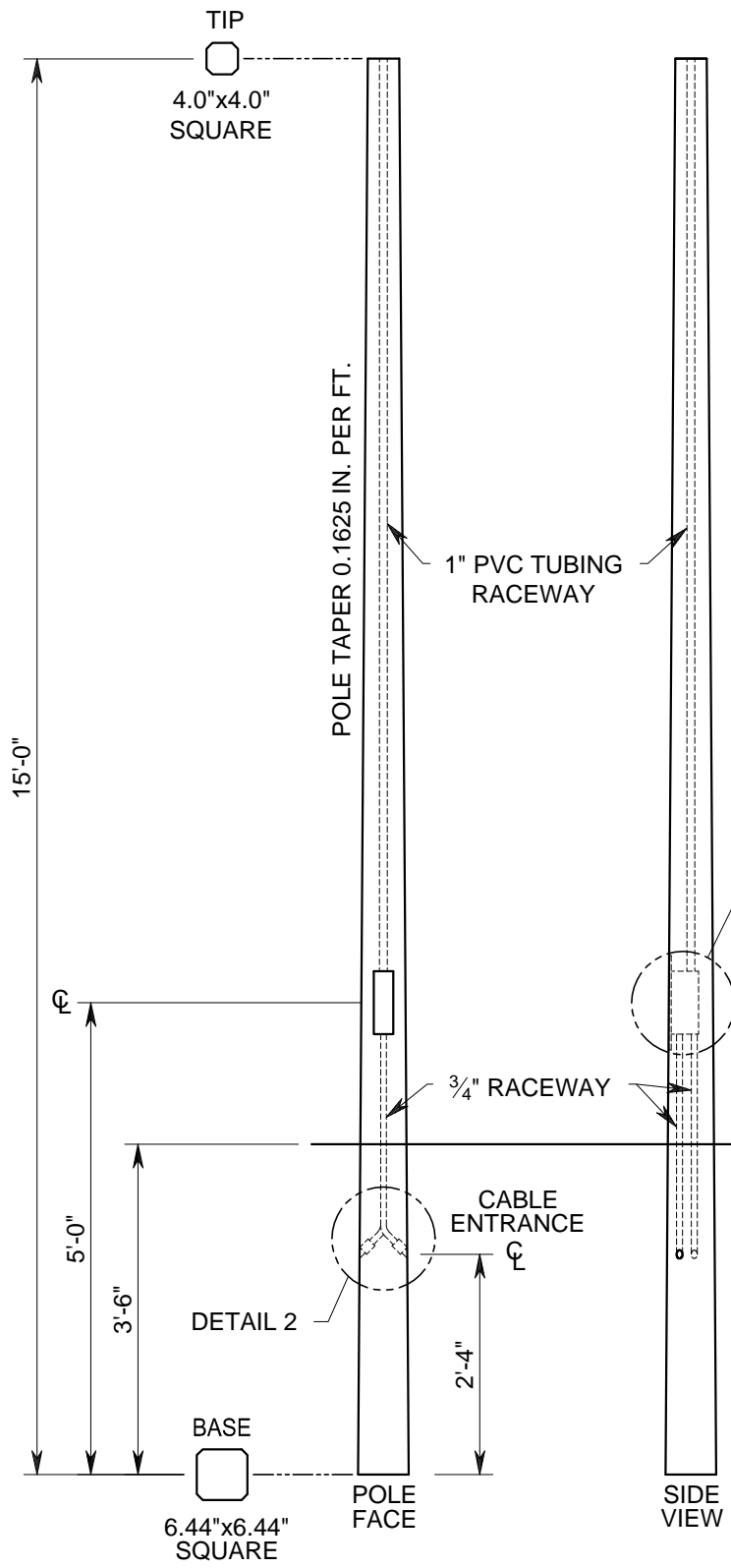

**TOP DETAIL
TOP OF POLE**

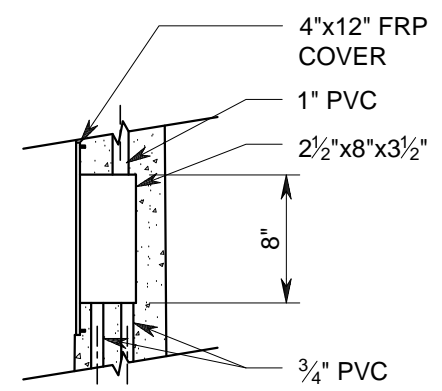

**DETAIL 1
HAND HOLE WITH
RECESSED COVER**

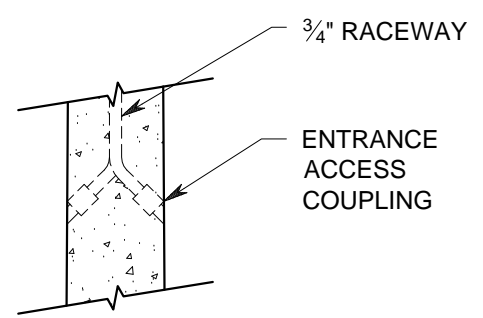

**DETAIL 2
CABLE ENTRANCE**

* Rule of Thumb: 10% of length of pole plus 2 feet.
Actual depth of embedment to be determined by customer.

| | |
|--|------|
| DESCRIPTION: 15'-0" TYPE I (SQ.) TOP MOUNT POLE | |
| TRUCK LOAD QTY: | QTY: |
| WEIGHT: 414 LBS. | |
| FINISH: SMOOTH FORM GRAY | |

STOCK CODE:
DISTRIBUTOR:



8892 Hwy 159 E
Bellville, TX 77418
www.lonestarprestress.com
Tel: (713) 896-0994
Fax: (713) 896-0762

DWG. NO: REV.
CAT. NO: 201002 DATE: 7/10/14
PROJECT:

APPROVED BY: DATE:

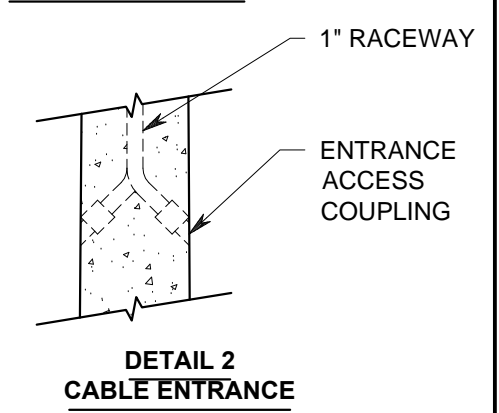
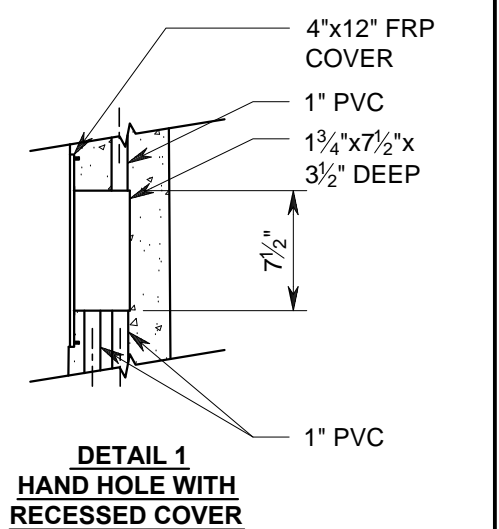
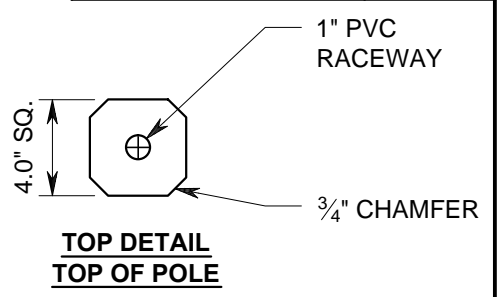
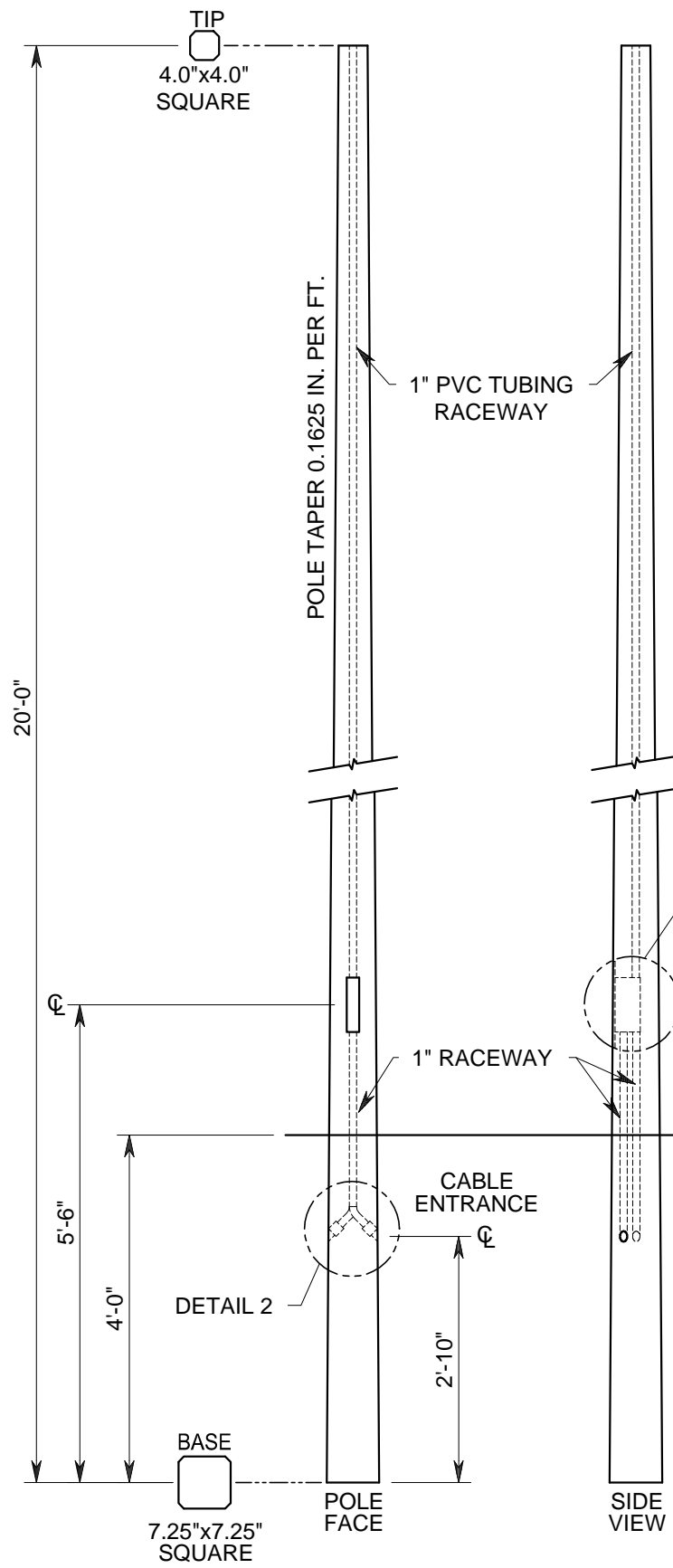

* Rule of Thumb: 10% of length of pole plus 2 feet.
Actual depth of embedment to be determined by customer.

DRAWING: N.T.S.

| | |
|--|------|
| DESCRIPTION: 20'-0" TYPE I (SQ. TOP MOUNT POLE) | |
| TRUCK LOAD QTY: | QTY: |
| WEIGHT: 649 LBS. | |
| FINISH: SMOOTH FORM GRAY | |

STOCK CODE:
DISTRIBUTOR:



8892 Hwy 159 E
Bellville, TX 77418
www.lonestarprestress.com
Tel: (713) 896-0994
Fax: (713) 896-0762

DWG. NO: _____ REV. _____
CAT. NO: 251002 DATE: 7/10/14
PROJECT: _____

APPROVED BY: _____ DATE: _____

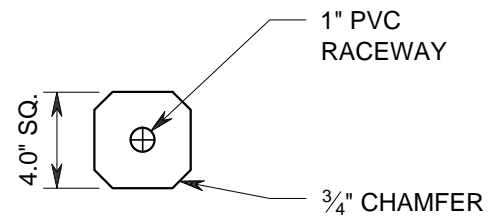
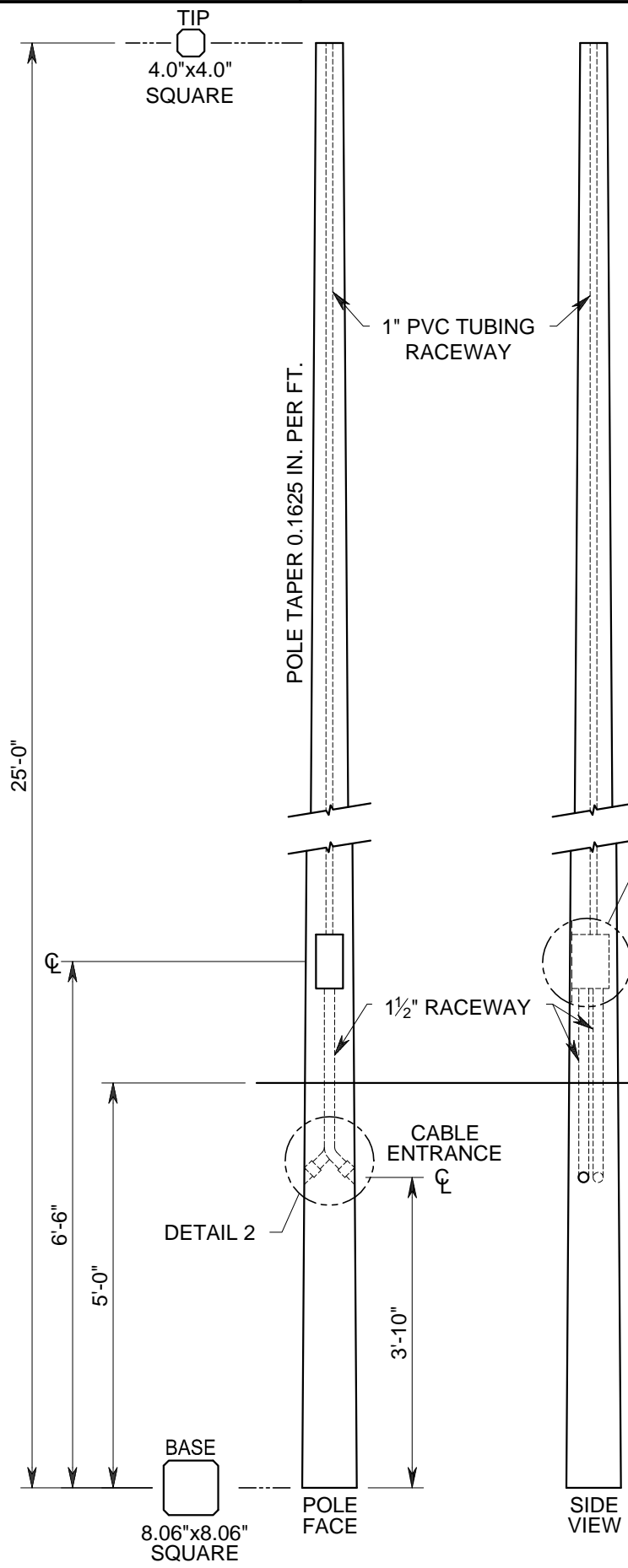

**TOP DETAIL
TOP OF POLE**

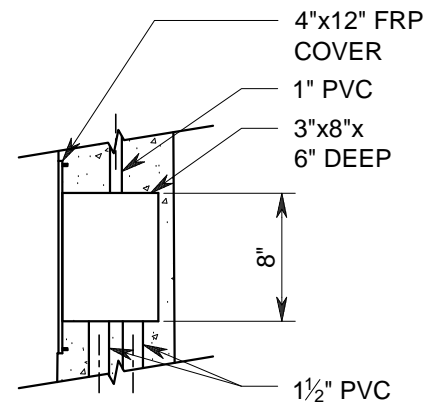

**DETAIL 1
HAND HOLE WITH
RECESSED COVER**

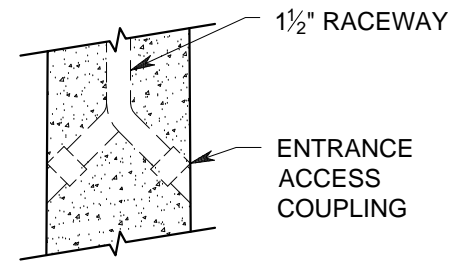

**DETAIL 2
CABLE ENTRANCE**

* Rule of Thumb: 10% of length of pole plus 2 feet.
Actual depth of embedment to be determined by customer.

| | |
|--|------|
| DESCRIPTION: 25'-0" TYPE I (SQ.) TOP MOUNT POLE | |
| TRUCK LOAD QTY: | QTY: |
| WEIGHT: 942 LBS. | |
| FINISH: SMOOTH FORM GRAY | |

STOCK CODE:
DISTRIBUTOR:



8892 Hwy 159 E
Bellville, TX 77418
www.lonestarprestress.com
Tel: (713) 896-0994
Fax: (713) 896-0762

DWG. NO: REV.
CAT. NO: DATE:
301002 7/21/14
PROJECT:

APPROVED BY: DATE:

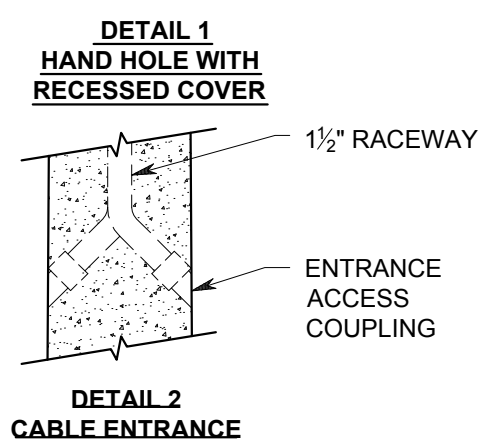
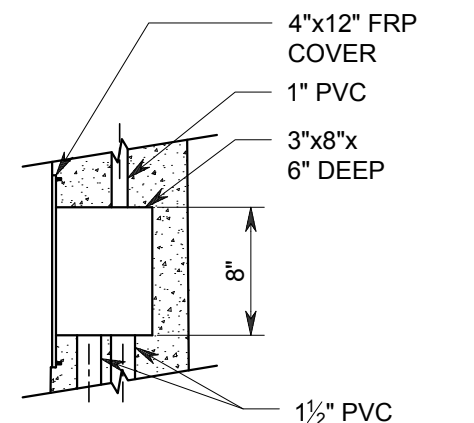
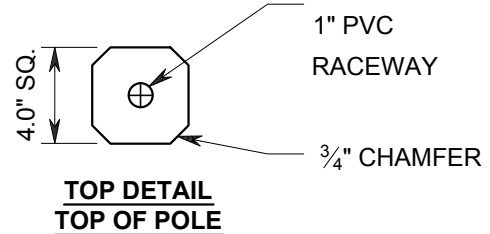
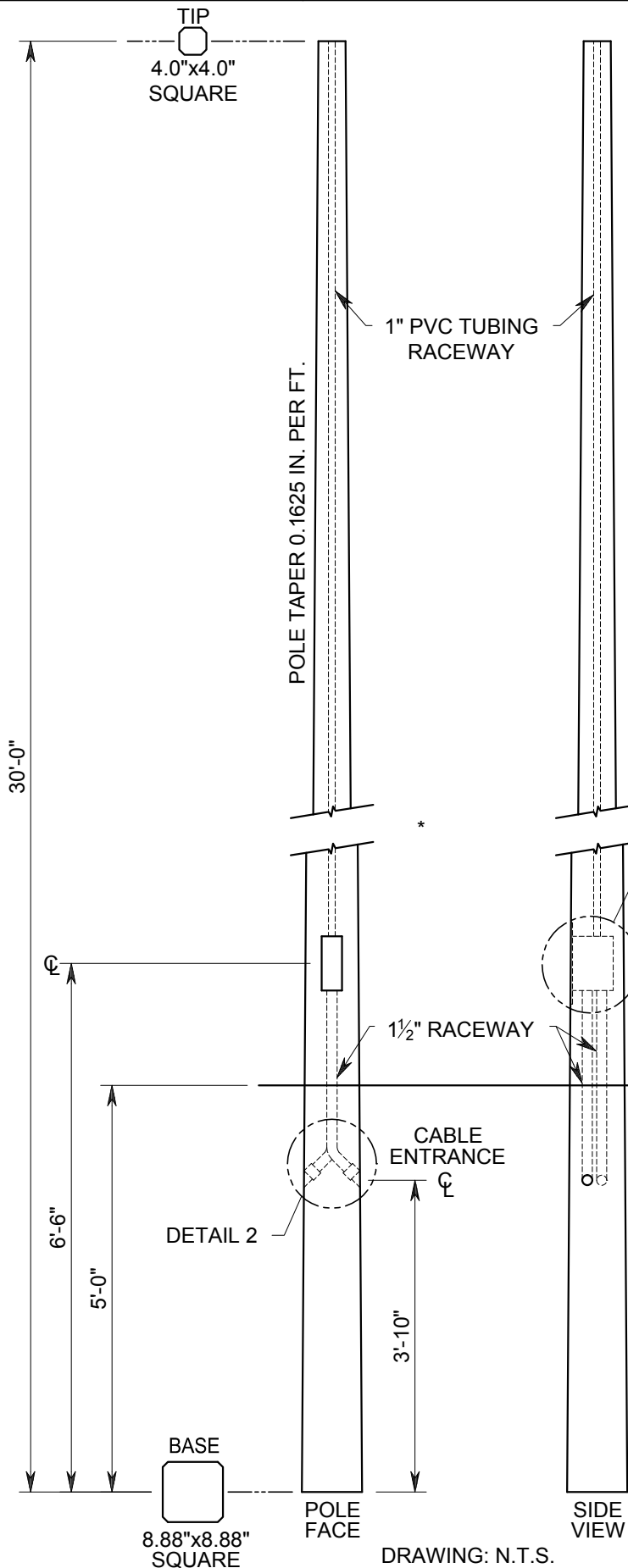

Rule of Thumb: 10% of length of pole plus 2 feet.
Actual depth of embedment to be determined by customer.

| | |
|--|------|
| DESCRIPTION: 30'-0" TYPE I (SQ.) TOP MOUNT POLE | |
| TRUCK LOAD QTY: | QTY: |
| WEIGHT: 1,302 LBS. | |
| FINISH: SMOOTH FORM GREY | |

DRAWING: N.T.S.

STOCK CODE:
DISTRIBUTOR:



8892 Hwy 159 E
Bellville, TX 77418
www.lonestarprestress.com
Tel: (713) 896-0994
Fax: (713) 896-0762

DWG. NO: REV.
CAT. NO: 351002 DATE: 7/10/14
PROJECT:

APPROVED BY: DATE:

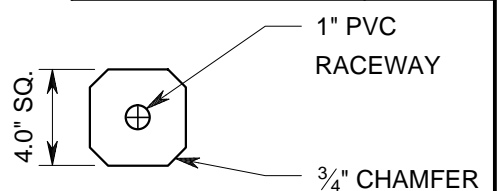
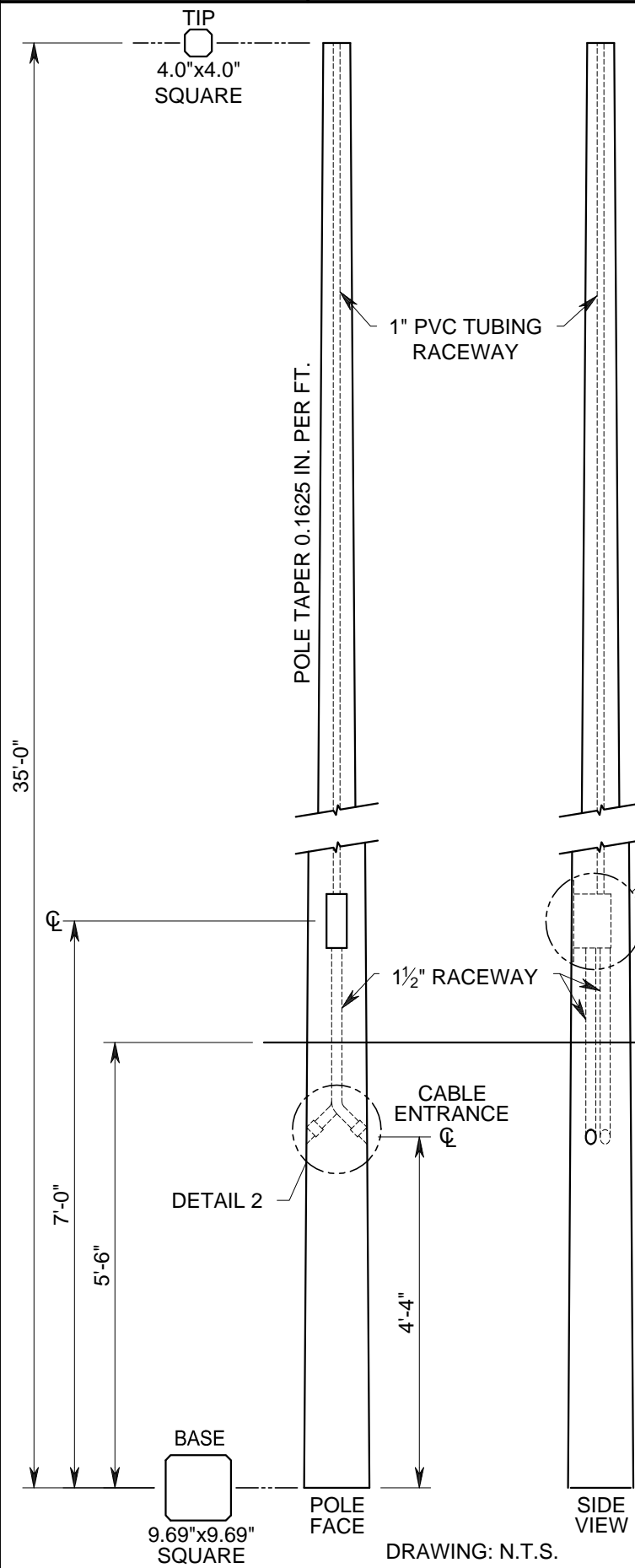

**TOP DETAIL
TOP OF POLE**

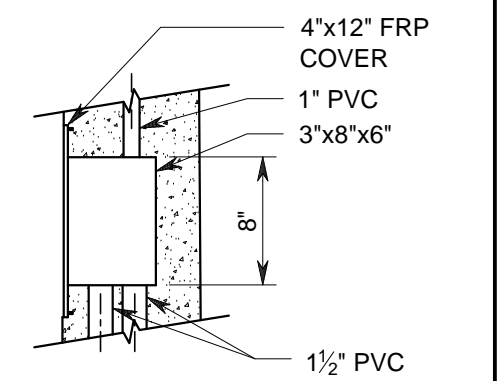

**DETAIL 1
HAND HOLE WITH
RECESSED COVER**

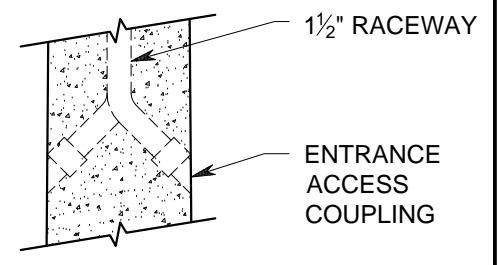

**DETAIL 2
CABLE ENTRANCE**

* Rule of Thumb: 10% of length of pole plus 2 feet.
Actual depth of embedment to be determined by customer.

| | |
|--|------|
| DESCRIPTION: 35'-0" TYPE I (SQ.) TOP MOUNT POLE | |
| TRUCK LOAD QTY: | QTY: |
| WEIGHT: 1,735 LBS. | |
| FINISH: SMOOTH FORM GREY | |

STOCK CODE:
DISTRIBUTOR:



8892 Hwy 159 E
Bellville, TX 77418
www.lonestarprestress.com
Tel: (713) 896-0994
Fax: (713) 896-0762

DWG. NO.:
CAT. NO.: 401002
PROJECT:
REV.:
DATE: 7/10/14

APPROVED BY: _____ DATE: _____

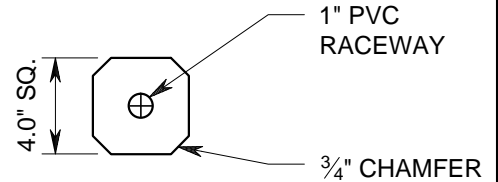
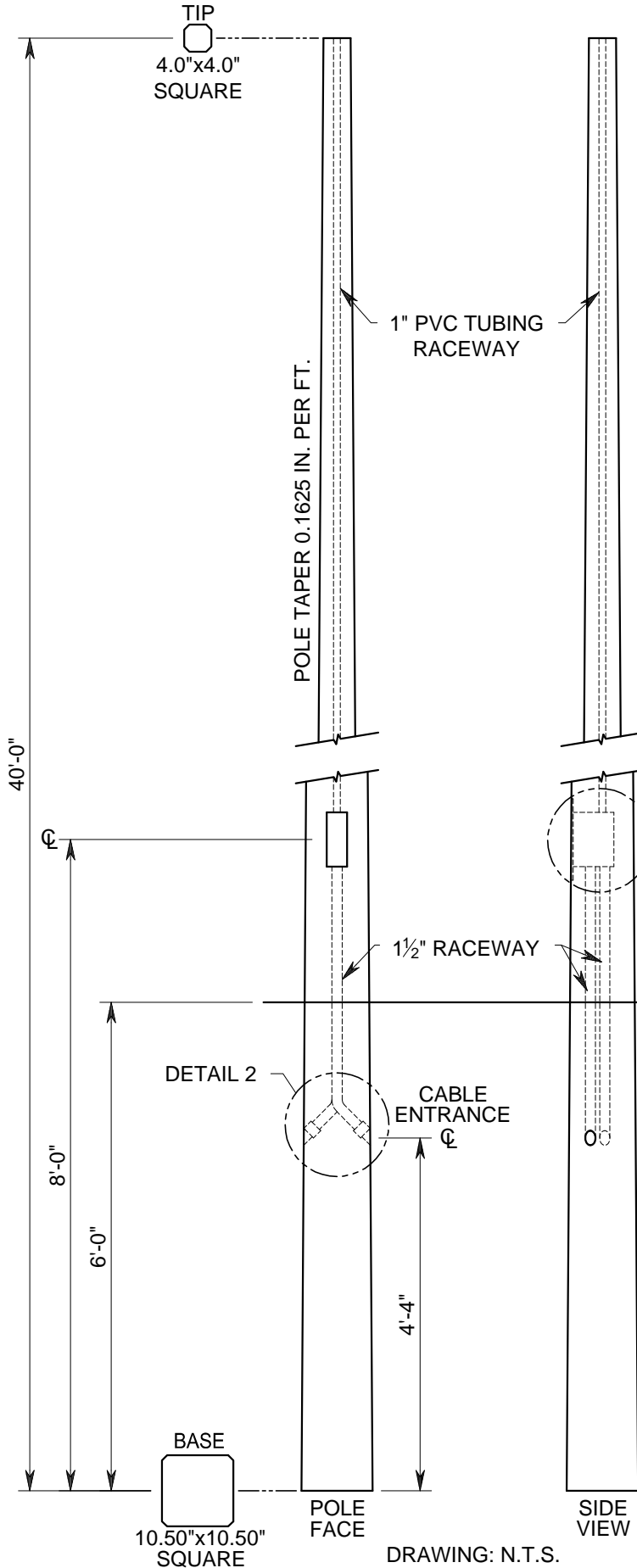

**TOP DETAIL
TOP OF POLE**

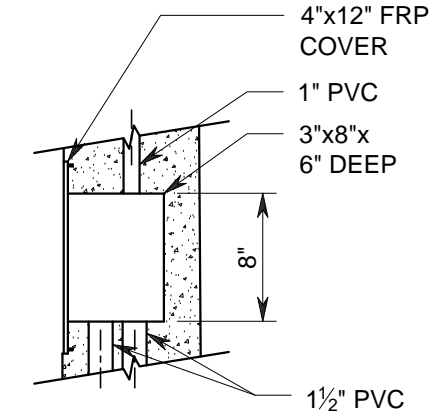

**DETAIL 1
HAND HOLE WITH
RECESSED COVER**

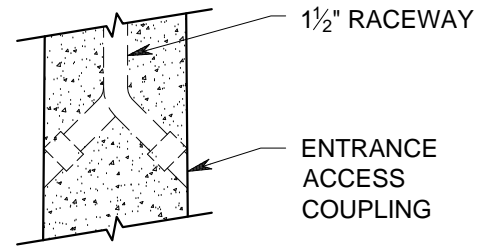

**DETAIL 2
CABLE ENTRANCE**

ROT* GROUND LINE

* Rule of Thumb: 10% of length of pole plus 2 feet.
Actual depth of embedment to be determined by customer.

DESCRIPTION: **40'-0" TYPE I (SQ.) TOP MOUNT POLE**

TRUCK LOAD QTY: _____
WEIGHT: 2,246 LBS.
FINISH: SMOOTH FORM GREY

QTY: _____