

## **PUBLIC WORKS DEPARTMENT**

Engineering Division

303 West Commonwealth Avenue, Fullerton, CA 92832-1775

Telephone: 714-738-6845

Website: [www.cityoffullerton.com](http://www.cityoffullerton.com)

**June 9, 2026**

### **INDEPENDENCE PARK GYM RENOVATION PROJECT NO. 54691 ADDENDUM NO. 2**

**TO:** ALL PLAN AND SPECIFICATION HOLDERS

THIS ADDENDUM, AS DESCRIBED BELOW, IS FOR USE OF CONTRACTORS AND SUBCONTRACTORS SUBMITTING BIDS ON THIS PROJECT. ALL BIDDERS SHALL INDICATE ON THE BID PROPOSAL FORM THAT THEY HAVE RECEIVED THIS ADDENDUM.

#### **CLARIFICATION TO CONSTRUCTION PLANS:**

**1. Plan Sheet A-3, Keynote #1**

See attached specification sheet for the 2230 Basketball/Multisport Scoreboard by Varsity Scoreboards. Provide the specified item or approved equal product.

**2. Plan Sheet A-3, Keynote #2**

See attached main-court backboard specification by Bison and cross-court backboard By Garad, available through Anthem Sports. Include the same rim/net and padding at the cross-court backboards. Provide the specified items or approved equal products.

**3. Plan Sheet A-3, Keynote #33**

See attached Sportsfield Gym Wall Padding specification, available through Anthem Sports. Provide the specified item or approved equal product.

**END OF ADDENDUM**



### 2230 Basketball/Multisport Scoreboard- Indoor

8' x 4' x 8"

Basketball Scoreboards Volleyball Scoreboards  
Wrestling Scoreboards

Standard Colors:

**Black - verify with City staff prior to ordering**

Fastest Lead Time in the Industry

Wireless Scoreboard Controller Standard

Flat-Rate Shipping

5-Year Limited Warranty

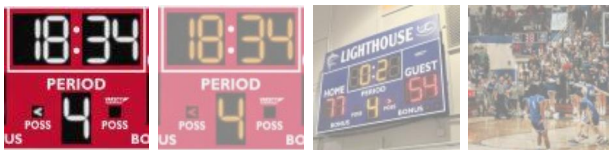

- 15" Red LED digits (White digit upgrade available)
- Protective digit shields
- Home/Guest score up to 199
- Double Bonus and Possession Indicators
- Clock counts down from and up to 99:59
- Built-in Horn
- Galvanized steel cabinet with powder coat finish
- Wireless scoreboard controller with 120 volt power adapter: optional rechargeable battery available
- 5- Year Limited Warranty

### Specifications

#### Dimensions

8' x 4' x 8"

#### Digit Sizes

15" digits. 2" dots and possession indicators

#### Weight

130 lbs.

#### Electrical

20-amp, 120-volt, 60-hertz, grounded AC circuit

### Manuals

[Installation Manual](#)

[Operation Manual](#)

### What's In The Box

Scoreboard in one (1) section

Mounting tools

Wireless scoreboard controller

12V adapter for wireless scoreboard controller

## Add-Ons

Include these options



Electronic Team Names  
ETNS



LCD Controller Carrying Case  
CS5  
**\$165**

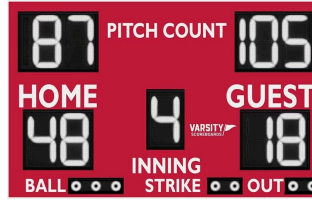

White Digits  
WHITEDIGITS  
**\$495**



8' Indoor School/Sponsor Panel  
SP8X21-ID  
**\$500**

8' Indoor Arched School/Sponsor  
Panel  
SPA8-ID

**\$695**

8' Indoor Truss  
SPT8-ID

**\$2,085**

## Frequently Asked Questions

[How long is Varsity's lead time for an order?](#)

[What type of service does Varsity Scoreboards offer?](#)

[Does the wireless remote include a battery?](#)

[What is included with my Varsity scoreboard?](#)

[How do I contact technical support?](#)

*Official Sponsor of  
Hometown Sports*

106 Max Hurt Drive  
Murray, Kentucky 42071

**866-394-5186**

**Get A Quote**



### Scoreboards

[Baseball Scoreboards](#)  
[Basketball Scoreboards](#)  
[Football Scoreboards](#)  
[Hockey Scoreboards](#)  
[Lacrosse Scoreboards](#)  
[Soccer Scoreboards](#)  
[Softball Scoreboards](#)  
[Volleyball Scoreboards](#)  
[Wrestling Scoreboards](#)

### Video Displays

[Outdoor Video Displays](#)  
[Indoor Video Displays](#)  
[Video Scorer's Tables](#)

### Tech Service

[Tech Service Videos](#)  
[Manuals](#)  
[Contact Tech Service](#)

### About Us

[Contact Us](#)  
[Satisfied Customers](#)  
[Architectural](#)  
[Photo Gallery](#)  
[Ordering Information](#)  
[Leasing Information](#)  
[Privacy Policy](#)

^  
TO TOP

Items marked in-stock ship same day (order by 2pm EST M-F) Items marked in-stock ship same day (order by 2pm EST M-F)

Home / Basketball / Backboards / Bison 48"x72" Premium Glass Basketball Backboard, Rim & Padding Package

# Bison 48"x72" Premium Glass Basketball Backboard, Rim & Padding Package

For use at the main court



Click image to expand view

Contact us with a question about this product

WARNING California residents: may contain chemicals that cause cancer/reproductive harm www.p65warnings.ca.gov

### Description

Bison's premium indoor basketball court upgrade package has everything you need to modernize your gym's tall basketball hoops, including a 48"x72" unbreakable glass backboard, choice of breakaway rim, and edge padding, saving you money and guaranteeing single source compatibility when replacing your gymnasium backboards. Choose from two exceptional rim options, guaranteed to elevate your court and each engineered for top-tier performance. First, consider the technologically advanced 180 breakaway rim. A top-of-the-line choice, the 180 rim features an innovative ring assembly that floats on 13 hardened chromium steel ball bearings allowing consistent breakaway pressure from 180 degrees of impact - anywhere from the middle of the paint, to the blocks, or any angle in between - for smooth flexibility and perfect dunk release. Its pressure release mechanism is also field adjustable, allowing you to fine-tune the feel and ensure ongoing adherence to NCAA ring testing rules. Featuring an advanced, consistent-response design and equipped with an upgraded, ultra-secure hideaway net attachment system with anti-whip net, this is the elite choice for players who demand peak performance at every level. Alternatively, the popular Elite Plus breakaway goal, a long-standing favorite for high school and college competition, provides a safety padded cover plate, AcuFlex adjustable tension release mechanism, 4-point lubrication system, and fully welded rim support along with a durable hideaway net attachment system and anti-whip net. Both rims are made for easy mounting to the unbreakable tall backboard, include all the necessary hardware and meet all NFHS and NCAA standards. Bison promises a lifetime warranty on their unbreakable competition glass backboard, the 48"x72" court upgrade solution engineered for ultimate durability and worry-free performance. The "off glass" goal mounting system, paired with a high-strength steel support structure and a glass cushioning gasket, ensures that over 98% of the stress from goal contact is absorbed, preventing energy transfer to the 1/2" tempered glass. This innovative design means you can be confident that even excessive hanging and dunking will not lead to glass breakage, safeguarding players and eliminating costly replacements. This Bison competition glass backboard is pre-drilled for quick installation of the original DuraSkin backboard padding, a top choice for player safety that come in a variety of colors. The Bison 48"x72" premium glass backboard package is a perfect and lasting solution for upgrading the tall, formerly traditional 48" glass boards currently in use across the country. Backed by an unconditional lifetime warranty, this premium basketball court backboard, paired with your choice of the 180 or Elite Plus rim, is the smart investment for a safe, reliable, and high-performing hoop experience.

### Brand

### ADDITIONAL INFO

Add to Quote

By clicking "Accept All Cookies", you agree to the storing of cookies on your device to enhance site navigation, analyze site usage, and assist in our marketing efforts. Further information is available in our Privacy Policy.

Cookies Settings Reject All

Accept All Cookies

### FEATURES

Package includes:

- **Backboard:**
  - Model BA48XL
  - Tall, 48" x 72"
  - 1/2" tempered glass
  - Off-glass rim mount
  - Glass cushioning gasket
  - White shooter square
  - Polished aluminum extrusion
  - High strength steel support structure
  - Pre-drilled for DuraSkin edge padding
  - Unconditional lifetime warranty
- **Goal Option - 180**
  - Model BA3180T
  - Breakaway rim in 180 degree flex
  - Floats on 13 hardened chromium steel ball bearings
  - Hideaway net attachment system
  - Adjustable pressure release mechanism
  - Positive lock release mechanism
  - 5/8" high tensile steel ring
  - Includes anti-whip net & mounting hardware
  - 2-year repair or replacement warranty
- **Goal Option: Elite Plus:**
  - Model BA35E
  - Breakaway rim
  - Hideaway net attachment system
  - AcuFlex adjustable tension release mechanism
  - Safety padded cover plate
  - 4-point lubrication system
  - 5/8" high tensile steel ring
  - Fully welded 1/4" rim support
  - Includes anti-whip net & mounting hardware
  - 5-year limited warranty
- **Edge padding:**
  - Model BA68U
  - DuraSkin Indoor backboard padding
  - Bolt-on installation
  - 10-year unlimited warranty
- Meets NFHS & NCAA standards
- SHIPS TRUCK

OTHERS IN THIS SERIES



\$1,926.95 A55-390  
**Bison 42"x72" Premium Glass Basketball Backboard, Rim &...**

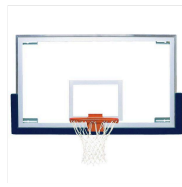

\$1,860.95 A55-391  
**Bison 42"x72" Standard Glass Basketball Backboard, Rim &...**

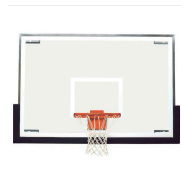

\$1,879.95 A54-013  
**Bison 48"x72" Standard Glass Basketball Backboard, Rim &...**

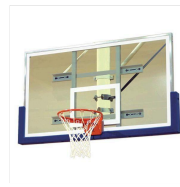

\$1,989.95 A55-392  
**Bison 42"x72" Conversion Glass Basketball Backboard,...**

COACH'S PICKS

PREVIOUSLY VIEWED & MORE

[Trustpilot](#)



MEET OUR TEAM



Anthem Sports © 2026 All Rights Reserved

By clicking "Accept All Cookies", you agree to the storing of cookies on your device to enhance site navigation, analyze site usage, and assist in our marketing efforts. Further information is available in our [Privacy Policy](#).

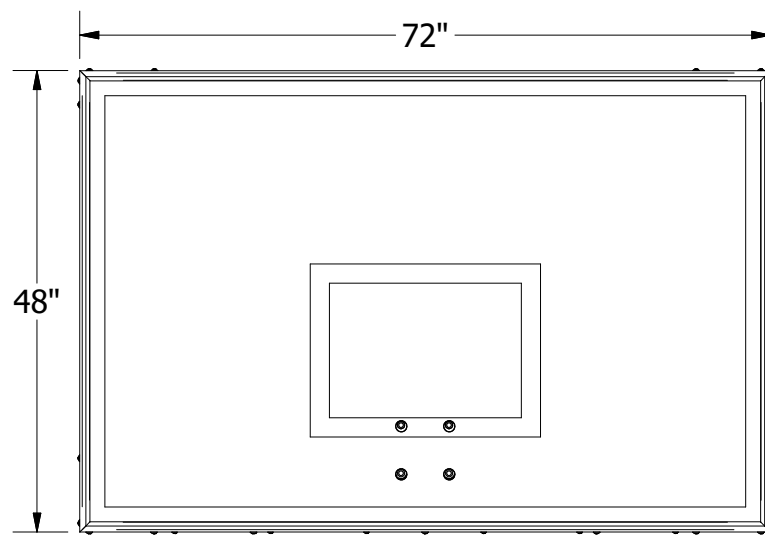

FRONT

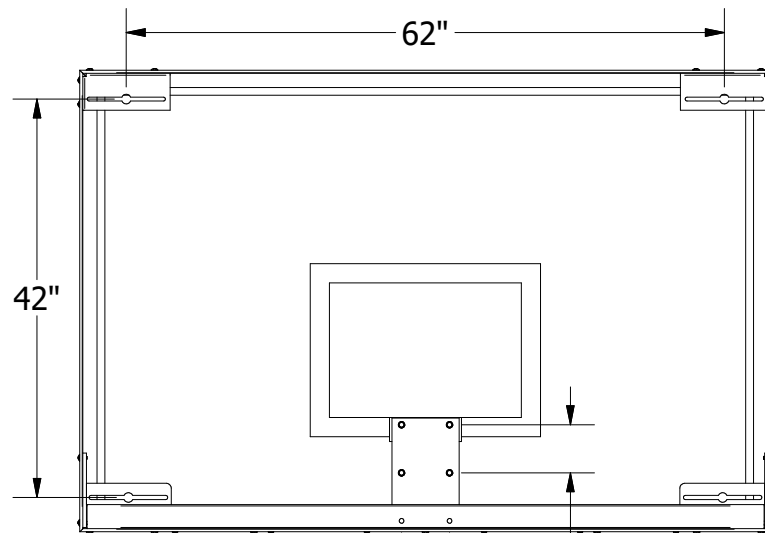

REAR

Backboard shall be 48" x 72" constructed of 1/2" thick tempered glass with an official white shooter's square and border and shall have 5" x 5" goal mounting pattern. Frame shall be aluminum extrusion held together in the top corners by means of 7 ga. steel corner brackets that provide for common 42" x 62" tall board corner mounting pattern. A fabricated steel rim support structure shall extend the full 72" width of the bottom of the backboard and be mounted to the aluminum framework in no less than 10 places. Steel spacers shall protrude through large holes in the glass for rim mounting. At no time shall the rim be allowed to contact the glass at any point during play when up to 1,000 lbs. of pressure is applied to the rim. Backboard shall meet all NCAA and National High School Federation standards and carry an unconditional lifetime warranty. Frame shall be predrilled to allow mounting of Bison Model BA68U DuraSkin Backboard padding. Installation to be completed in accordance with manufacturer's instructions. Do not scale drawings. Board shall weigh 230#.



## PRODUCT SPECIFICATION

BA48XL UNBREAKABLE COMPETITION TALL GLASS BACKBOARD

REVISED 8/01/19

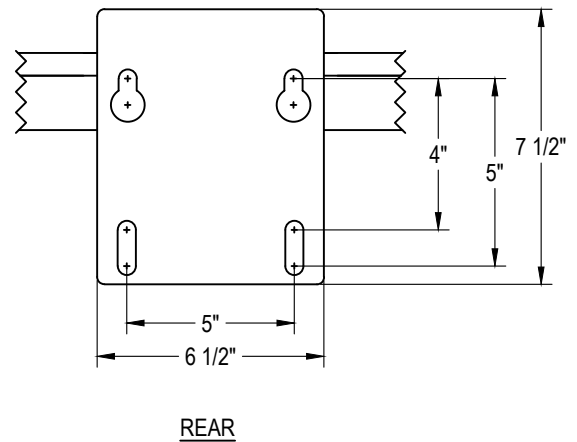
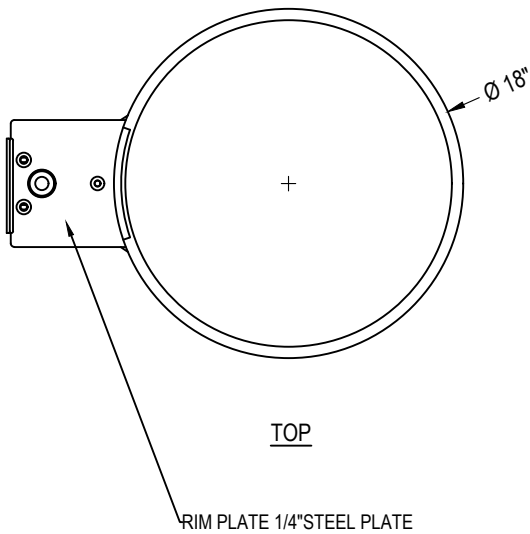
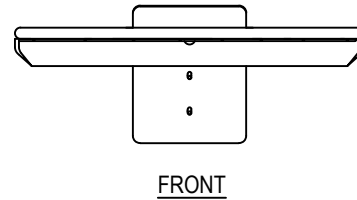
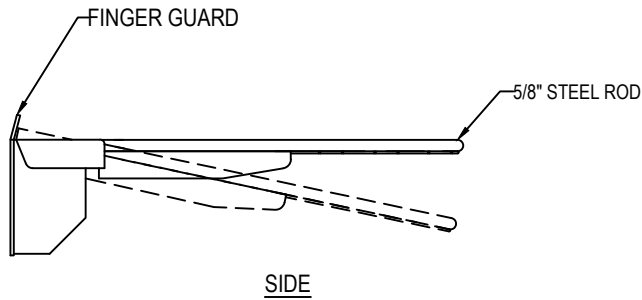

Goal shall be designed and constructed so that when downward pressure exceeding the release pressure setting is applied at any location within 90° either to the left or to the right of the point on the ring farthest from the backboard, the entire ring assembly will pivot downward. The release pressure setting shall be field adjustable and be designed with a detent style positive lock mechanism so that the ring cannot be released until the setting pressure is exceeded. Ring shall be constructed of 5/8" diameter AISI 1018 cold drawn carbon steel. Tubular segments shall be spaced and welded a full 360° around the lower surface of the 5/8" ring to allow the goal net to be securely attached without fasteners by means of a single nylon cord. All steel components that come in contact with other steel components during release of the ring assembly shall be heat treated to a minimum depth of 1/50" and hardness of 50 on the Rockwell "C" scale. Goal shall meet all applicable NCAA, FIBA and National High School Federation rules including NCAA Men's Division I rule regarding rebound elasticity testing. Release mechanism shall be isolated from player contact and pinch point risk by means of a steel coverplate. Backplate shall have both a 5" x 4" and a 5" x 5" hole pattern to allow mounting to any brand of front mount backboard that is approved for official competition play. All goals shall have an orange powder coat finish and include anti-whip nylon net, zinc plated grade 5 mounting hardware, two (2) net attachment cords and have a 2-year repair or replacement warranty. For replacement net cords order BA35ARC. Goals without positive lock mechanisms, without 360° tubular style net attachment or that do not release at all points along the front 180° circumference of the ring shall not be considered equal. Made in USA. Rim shall weigh approximately 39#. Installation to be completed in accordance with manufacturer's instructions. Do not scale drawings.



## PRODUCT SPECIFICATION

BISON BASELINE™ BA3180T (180° BREAKAWAY GOAL)

REVISED 11/20/20

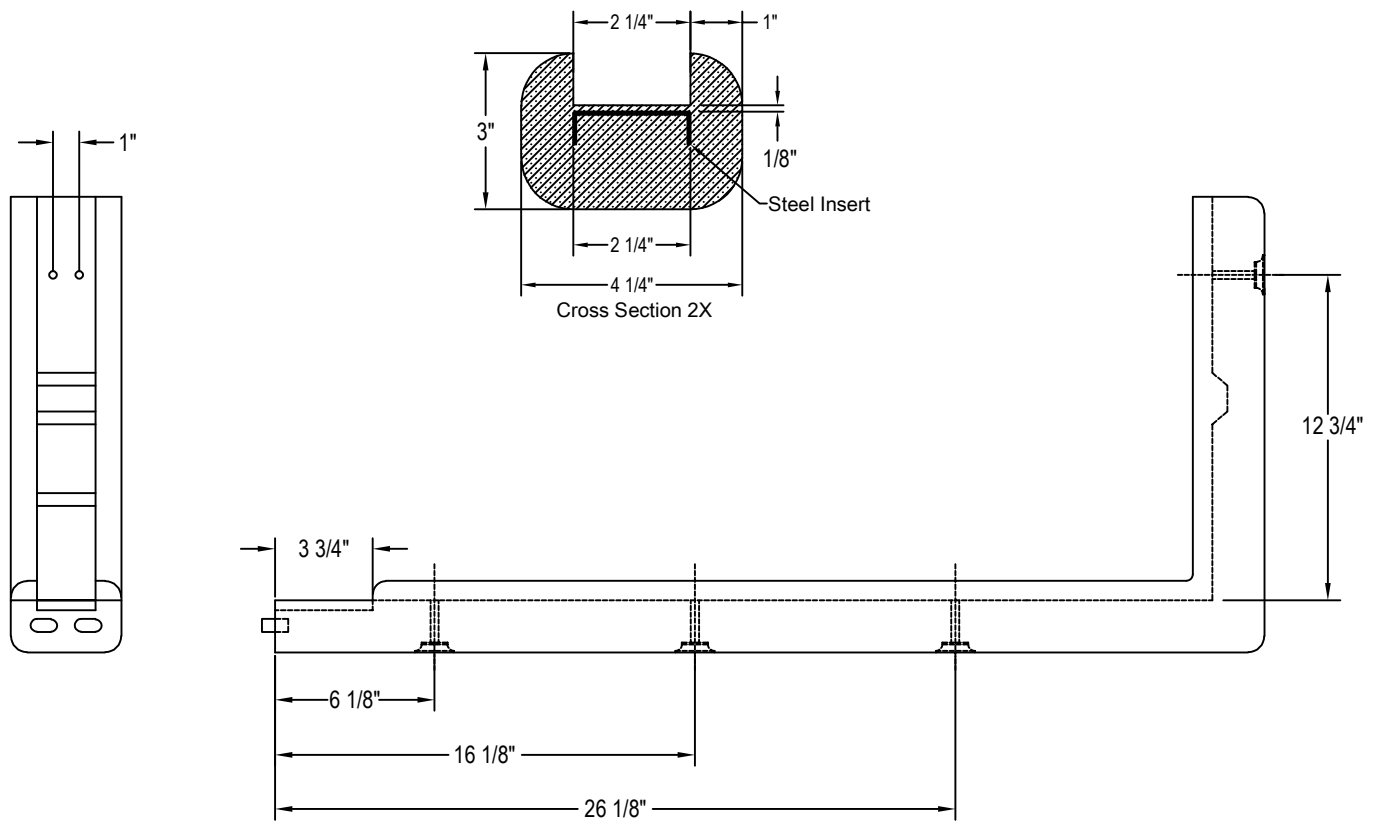

Padding shall be molded to meet or exceed all standards set forth by the NCAA, National High School Federation and FIBA. Padding shall be cellular construction with a skin of an average minimum thickness of 3/50". The skin shall be produced integral to the cushion using a self-skinning molding process. The tear strength of the skin shall be a minimum 125 psi. The padding system shall be capable of mounting to all brands and styles of 72" rectangular backboards by means of eight bolts (provided). A steel track molded into the padding shall provide rigidity and strength to the mounting system. The corners of the padding shall be molded square for maximum safety and shall not require mitering, gluing or forming for attachment. All hardware shall be provided. The two section padding system shall be available in official Gray, Royal, Navy, Columbia Blue, Scarlet, Orange, Gold, Kelly Green, Forest Green, Black, Maroon, Purple, Vegas Gold, Cardinal, Brown, Burnt Orange and Pink. Colors shall be continuous throughout the thickness of the padding, not only on the skin. Installation to be completed in accordance to manufacturer's instructions. Do not scale drawings. The warranty shall extend for 10-years and cover tearing and deterioration, as well as detachment from the backboards and weigh approximately 12#.



## PRODUCT SPECIFICATION

BA68U DuraSkin RECTANGULAR BACKBOARD PADDING

REVISED 8/1/17

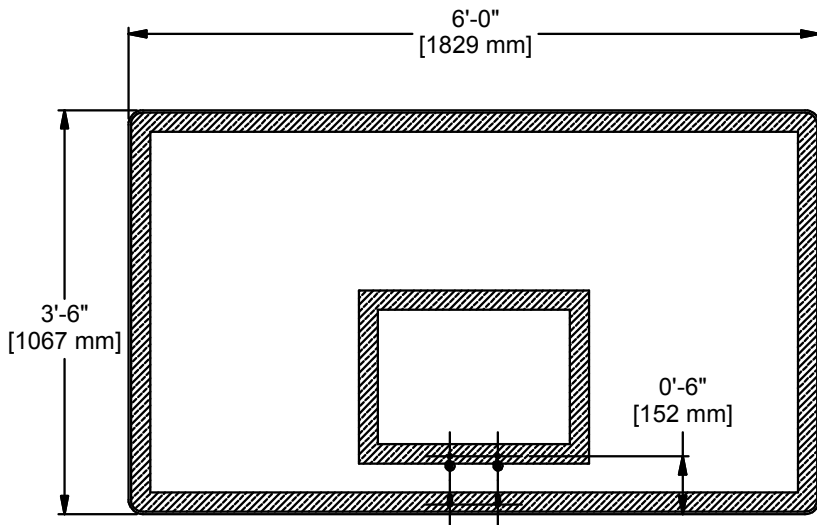

FRONT VIEW

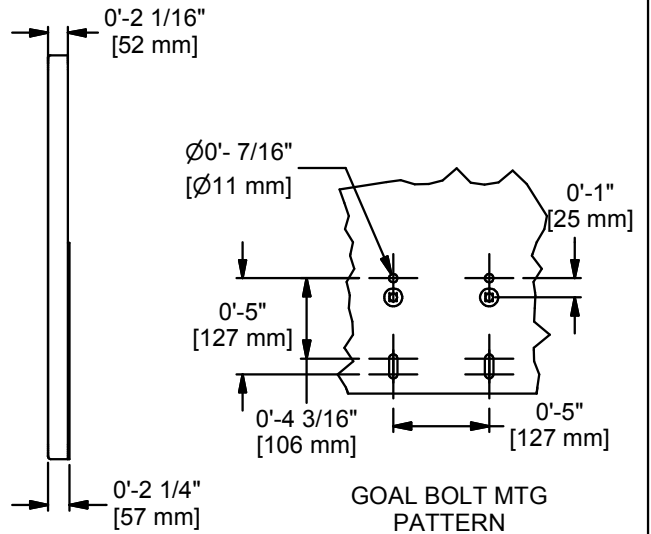

GOAL BOLT MTG PATTERN

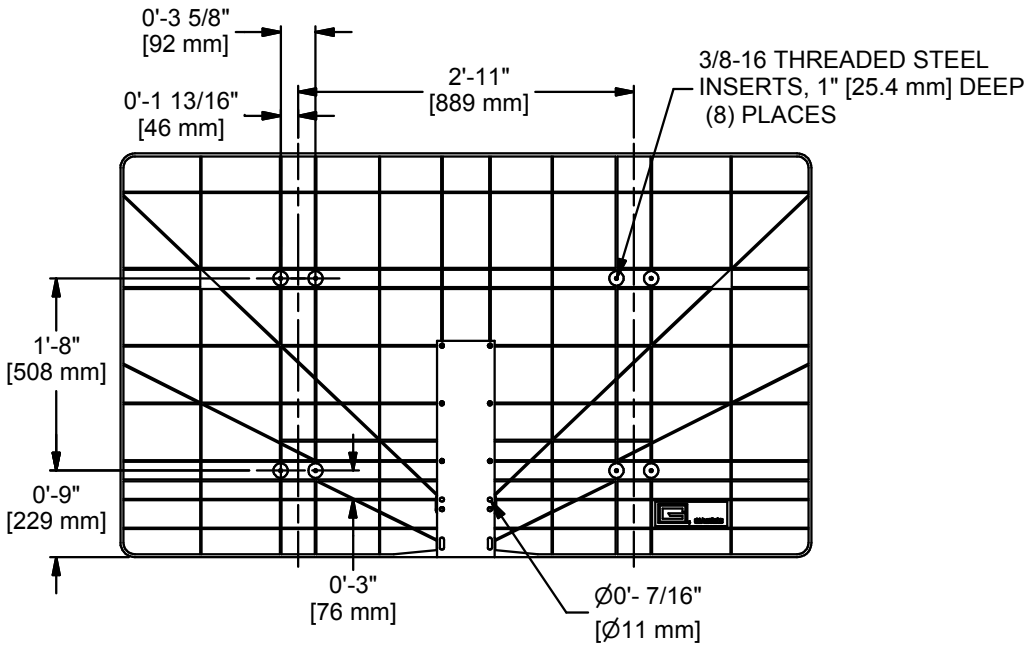

REAR VIEW

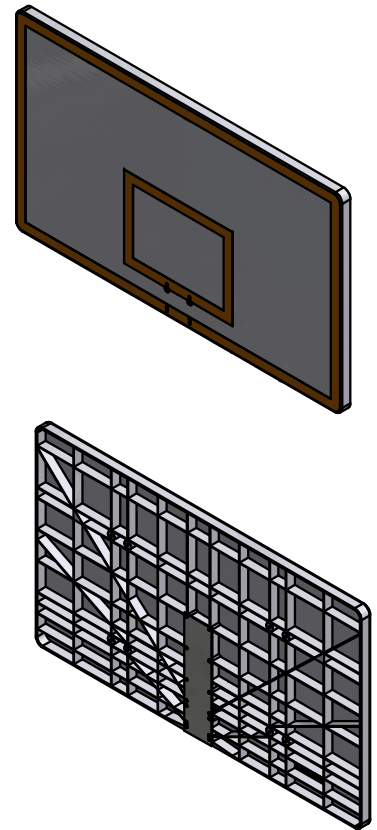

BOARD TO BE FINISHED IN GLOSS WHITE WITH ORANGE TARGET AND BORDER.

BACKBOARD WEIGHS 86 LBS. [39.0 Kg]

C	JJC	11/13/17
B	DWP	08/05/09
A	JJC	05/20/09
REV	BY	DATE

Gared Holdings, LLC  
9200 E. 146th St. Noblesville, IN 46060

THIS DOCUMENT CONTAINS TRADE SECRET AND OTHER MATERIALS WHICH ARE PROTECTED BY CONFIDENTIALITY NOTICE AND AGREEMENT AND BY COPYRIGHT. ANY USE OR COPYING OF THIS DOCUMENT EXCEPT AS AUTHORIZED BY GARED HOLDINGS, LLC IS STRICTLY PROHIBITED.

42"X 72" RECT MOLDED BOARD, ORG BORDER

DRAWN	CONNERLEY	DATE	4/1/2009	DATE ISSUED
APPROVED		DATE		
FILE LOC. Q:\Inventor Files\Specification Files\07_Backboards				
SIZE	SCALE	SHT. NO.	PART NO.	REV
A	NONE	1 OF 2	1342B-R001	C



**MODEL 1342B**  
**42" X 72" RECTANGULAR FIBERGLASS BACKBOARD**  
**WITH BORDER AND TARGET**

The 1342B backboard shall be molded from fiberglass with a tensile strength of 8,900 to 11,700 PSI and shall have 23% to 27% fiberglass content by weight. All surfaces shall be high gloss white in color with orange border and target silk screened on face of bank for permanent markings.

Board shall have goal mounting holes shall be on 5" horizontal and 5" vertical centers and holes on 5" horizontal and 4 ½" vertical centers to accommodate a variety of goals.

**ACCESSORIES**

**GOALS**

See Goal-Board Matrix specification sheet for goal compatibility.

Subject to design change and current manufacturing practices.

Items marked in-stock ship same day (order by 2pm EST M-F) Items marked in-stock ship same day (order by 2pm EST M-F)

Home / Facility / Wall Pads / Sportsfield 2' x 6' Gym Wall Pads w/ Z-clip Attachment

# Sportsfield 2'x6' Gym Wall Pads w/ Z-clip Attachment

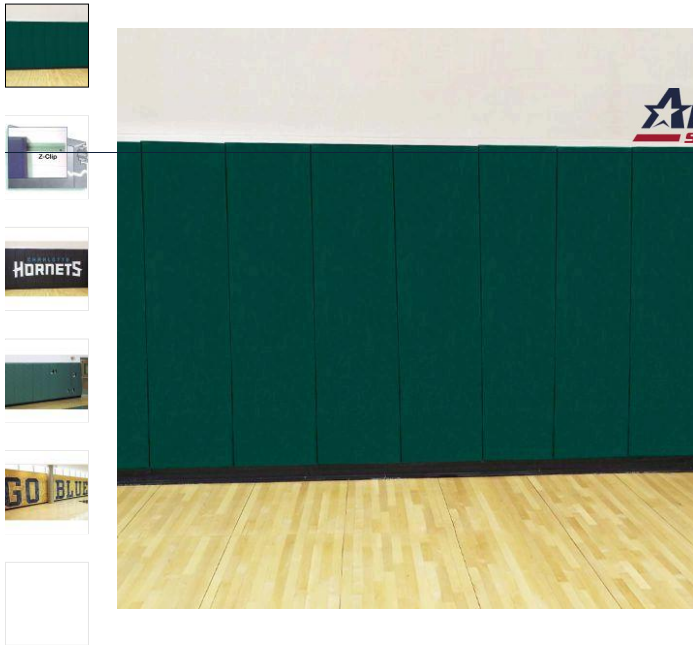

Height & color to match existing condition. Verify with City staff prior to ordering.

Click image to expand view

[Contact us with a question about this product](#)

WARNING California residents: may contain chemicals that cause cancer/reproductive harm [www.p65warnings.ca.gov](http://www.p65warnings.ca.gov)

### Description

These expertly crafted 2' x 6' panels by Sportsfield Specialties / Promats feature a Z-clip attachment that provides excellent wall protection to absorb shock impact. The padding is constructed with a wood backing and 2" thick high impact foam fortified with a 14 oz. leather-grained vinyl covering. Customize the panels with digitally printed lettering/logos at an additional cost. Contact Anthem Sports for artwork pricing and details.

### Brand

### ADDITIONAL INFO

Typically ships in 6-8 weeks

Add to Quote

Add to Compare

### FEATURES

SHIPS TRUCK - Freight Quote Required

- **HOW TO REQUEST A QUOTE:**
  - Enter quantity and choose color above
  - Click "ADD TO QUOTE" button above
  - Submit quote for sales assistance & formal quote
- 2' x 6'
- Z-clip attachment on top of pad for a cleaner look
- 14 oz leather grained vinyl, bonded foam
- 7/16" exterior grade OSB plywood backing
- Vinyl is Class A rated fire retardant
- Cut outs are done in the field

- Meets ASTM 2440 standard for indoor wall padding
- *Mounting hardware NOT included*
- **Digital graphics/lettering available at an additional charge (call for pricing)**
- **Vector artwork required for custom graphics**
- [Click here for info on artwork requirements](#)

---

---

**OTHERS IN THIS SERIES**

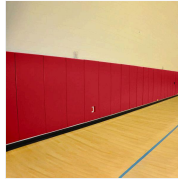

\$177.95      A77-231  
**Sportsfield 2'x6' Gym  
Wall Pads w/ 1" Top &  
Bottom Nailing Margin**

---

---

**COACH'S PICKS**

---

---

**PREVIOUSLY VIEWED & MORE**

[Trustpilot](#)



Anthem Sports © 2026 All Rights Reserved



Meets/Exceeds ASTM F2440-11  
Requirements for Impact Absorption

14 oz. Indoor Vinyl, Class A Fire Rated (ASTM E-84),  
Various Standard Colors Available

Appropriate Substrate: Masonry,  
Wood, Drywall, Metal Framing, Etc.  
(By Others)

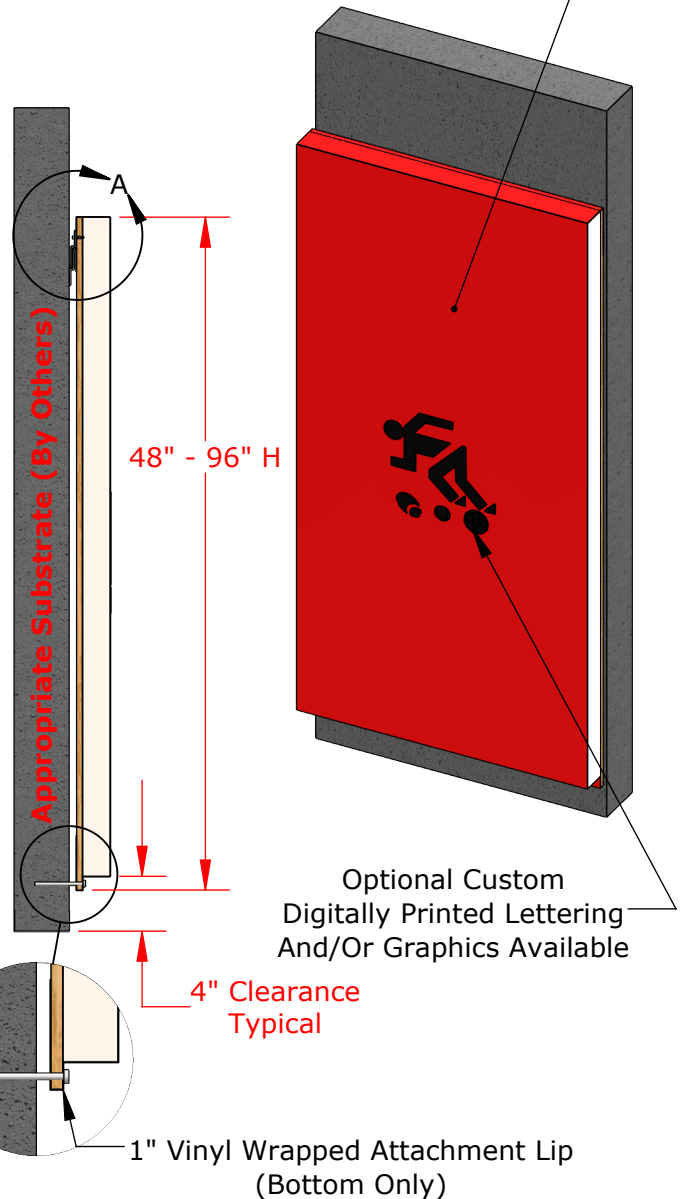
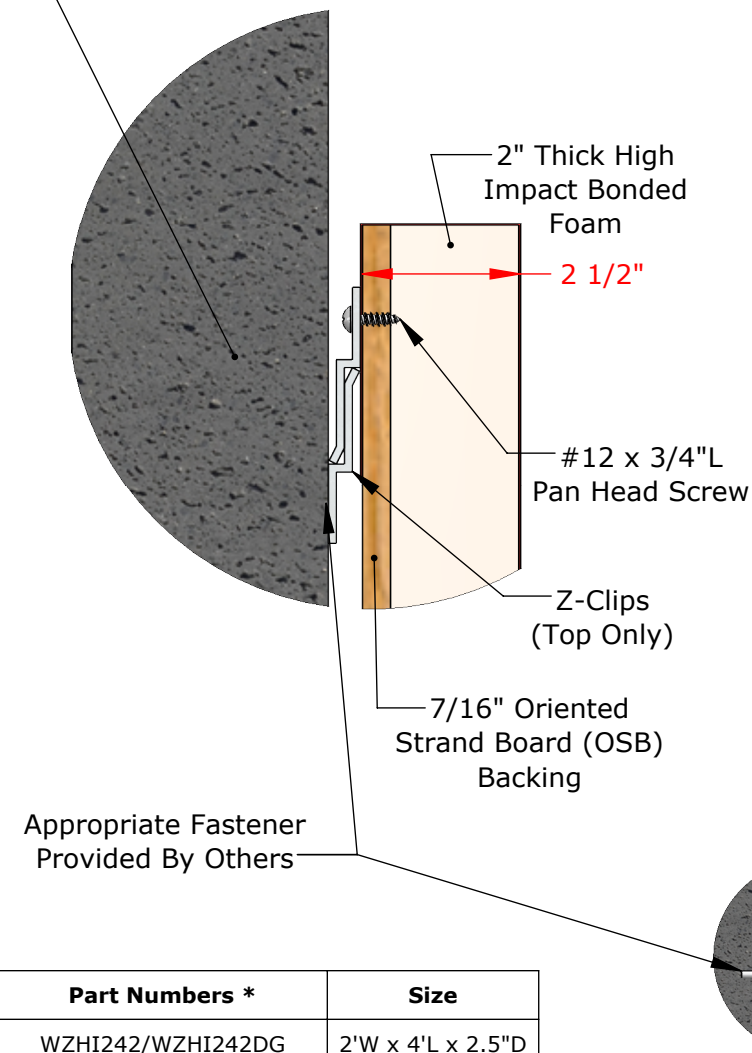

Part Numbers *	Size
WZHI242/WZHI242DG	2'W x 4'L x 2.5"D
WZHI252/WZHI252DG	2'W x 5'L x 2.5"D
WZHI262/WZHI262DG	2'W x 6'L x 2.5"D
WZHI272/WZHI272DG	2'W x 7'L x 2.5"D
WZHI282/WZHI282DG	2'W x 8'L x 2.5"D
WZHI-NSS/WZHIDG-NSS	_ 'W x _ 'L x 2.5"D

\*DG Part Number Denotes Custom Digitally Printed Graphics

Final Layout and/or Graphic Rendering to be Completed upon Verification of Field Measurements

**PROPRIETARY AND CONFIDENTIAL**

THE INFORMATION CONTAINED IN THIS DRAWING IS THE SOLE PROPERTY OF SPORTSFIELD SPECIALTIES INC. ANY REPRODUCTION IN PART OR AS A WHOLE WITHOUT THE WRITTEN PERMISSION OF SPORTSFIELD SPECIALTIES INC. IS PROHIBITED.

**WZHI High Impact Wall Pad  
Z-Clip Top and Attachment Lip Bottom**

Not To Scale

Sportsfield Specialties Inc 08112020