

BLACK Series

Extreme Ruggedization SSD's SATA/USB Flash Drive FRED^(C)

OVERVIEW

Designed as a Flexible Ruggedized External Drive, FRED is part of Memkor's Black Series SATA, PCIe and USB Solid State Drives (SSD's).

FRED provides an easy to deploy, highly rugged and high-performance non-volatile storage module that can be attached to ATR enclosures via 38999 connectors or cable.

FRED is an alternative to ATR internal storage cards freeing valuable internal ATR slots for other functions and can help to extend the life of the existing systems.

Memkor BLACK Series SSDs are built upon field proven Bill of Material (BOM) and ruggedization design practices that ensure reliable operations in most extreme environmental conditions.

FRED offers the capacities for up to 2TB in short and 4TB in long versions with performance up to 300 MB/s and 500 MB/s for USB and SATA interfaces. FRED optionally includes Write Protect, Military grade Secure Erase and is compliant with cryptographic module requirements.

MEMKOR M⁺ SECURITY - CUTTING-EDGE DATA PROTECTION
FRED leverages Memkor's FIPS 140-2 efforts and its processor is FIPS 197 validated. In addition, FIPS 140-2 validated cryptographic module can be embedded in the mechanical FRED enclosure. The FIPS 140-2 includes strength testing of encryption engine, security algorithms and methods used to authenticate users, safe-keeping of security parameters and anti-tempering measures. The encryption management are either FIPS validated procedures or TCG OPAL method. The Shadow MBR allows for pre-boot authentication and the use of the cryptographic module as a boot drive.

Data protection includes a Write Protect function option which ensures data integrity and prevents malicious or accidental Data alteration. The Write Protect function can be enabled and disabled by the user through software or hardware triggering.

RELIABILITY

Through the use of the highest reliability MLC and SLC NAND, combined with the state of the art flash management techniques, strong EDC/ECC/CRC, end-to-end data protection strategy and sudden power loss safeguards integrated in software and hardware, Memkor's BLACK Series SSDs provide the highest level of reliability, durability and endurance.



SUMMARY

- ❑ Rugged removable Flash Drive
- ❑ Up to 2/4TB Industrial SLC/MLC NAND
- ❑ SATA 6G or USB 3.1
- ❑ 38999 ruggedized connector
- ❑ FIPS 140-2 Level 2 validated module inside⁽⁴⁾⁽⁵⁾
- ❑ Water Resistant

FRED APPLICATIONS AND VALUES

- ❑ Secure and rugged portable Data recorder and/or Data loader
- ❑ Can be used as a Boot drive
- ❑ Easy to connect via a snap-on or twist-on connectors
- ❑ Multiple 38999 connectors supported
- ❑ Alternative to internal ATR storage card
- ❑ Expansion storage for sealed computers
- ❑ Moving Data between platforms
- ❑ All models FIPS 197 validated
- ❑ Optional TCG OPAL
- ❑ HW or SW triggered Crypto and Secure Erase
- ❑ HW or SW enabled Write Protect
- ❑ End-to-end Data protection
- ❑ End-to-end operation monitoring and recording
- ❑ Sudden power loss safeguards
- ❑ Standard conformal coating
- ❑ Use of high reliability components
- ❑ Each SSD thoroughly tested
- ❑ Locked BOM and obsolescence management
- ❑ Custom firmware and features when required
- ❑ PCIe interface can be accommodated
- ❑ 7 year/TBW limited warranty

ABOUT BLACK SERIES

Memkor's 2nd generation BLACK Series SATA and PCIe SSDs combine innovative ruggedization strategy through mechanical design, manufacturing and assembly processes, built upon ORANGE and BLUE Series SSD architecture and capabilities. The BLACK Series drives are successfully deployed in applications where the most challenging shock and vibration are the norm. The BLACK series includes a standard form factor 2.5" SFF-8201 and also some proprietary, application specific fixed or removable storage solutions. The BLACK Series shares the security and functional features with the ORANGE and BLUE Series devices.

MEMKOR—PART OF YOUR PROJECT

- We will support your design process
- Each SSD undergoes ESS test
- We offer Locked BOM Management
- We offer obsolescence management

MEMKOR FRED BLACK SERIES SPECIFICATION

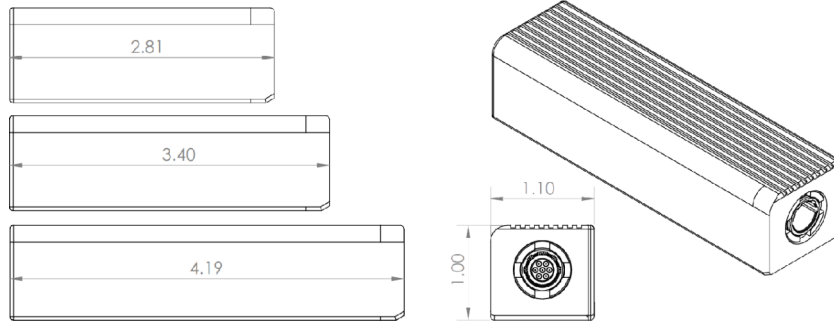

Standard Form Factor	Small handheld form factor
Interface	SATA 6G, 3G, 1.5G USB 3.1 for easy Host computer connection (standard cables available)
Data throughput	SATA 6G: up to 500/500 MB/s read/write SATA 3G: up to 250/250 MB/s read/write USB 3.1: up to 300/300 MB/s read/write
Maximum Capacity	<ul style="list-style-type: none"> • up to 1024/512 GB MLC/pSLC NAND FRED—Short • up to 2048/1024 GB MLC/pSLC NAND FRED—Mid • up to 4096/2048 GB MLC/pSLC NAND FRED—Long
Temperature Range	<ul style="list-style-type: none"> • -40°C to 85°C Industrial/Military • 0°C to 70°C Commercial
Vibration/shock	• 16.3 GRMS 10-2000Hz / 50G 11ms
Water impermeability	• 3 ft
Data Reliability	<ul style="list-style-type: none"> • Flash managed by static and dynamic wear leveling and powerful ECC/CRC • Uncorrectable bit error rate (UBER): less than 10⁻¹⁶
Data Retention	• 1 year at 30°C when power off and TBW reached ⁽³⁾
Endurance ⁽¹⁾	<ul style="list-style-type: none"> • 800 TBW (512 GB MLC NAND) • 8,200 TBW (512 GB pSLC NAND)
Data Security	<ul style="list-style-type: none"> • FIPS 197; optional FIPS 140-2; optional TCG OPAL • Enhanced ATA Security/Authentication support • Military grade Secure Erase and Crypto-Erase • HW and/or SW Write Protect
Component reliability	• MTBF: >1,000,000 hrs ⁽²⁾
Health monitoring	<ul style="list-style-type: none"> • S.M.A.R.T. to report system health • Thermal performance monitoring and management

- (1) Per JEDEC219. Contact Memkor for TBW for other capacities and specific workloads.
- (2) Contact Memkor for MTBF prediction for specific environmental conditions and field MTBF data.
- (3) Per JESD47/JEP122. Contact Memkor for Data Retention prediction for your application.
- (4) Selected models
- (5) C3750

DISCLAIMER: Memkor, Inc. reserves the right to change products, specifications and information without notice.

Memkor® is an American engineering company dedicated to providing flash solid state storage solutions for defense, industrial and enterprise applications. We create secure, reliable, robust and innovative solutions with rich feature sets, tailored, as required, to meet your technology investment objectives. We are dedicated to delivering on our promises. We simply believe that your satisfaction enables the continuous success of our company.



Memkor, Inc., 10051 E Dynamite Blvd., Suite 120, Scottsdale, Arizona 85262, USA

Tel: 602.424.6246
Fax: 480.657.0298

https://www.memkor.com
email: sales@memkor.com

ISO 9001:2015 Certified



Preferred Registrar Group Inc.