

2026

The Program Guide

F-16 & OTHER JETS

WHAT'S INSIDE:

- **ADVANCES IN TECHNOLOGY & THE SUPPLIER BASE**
 - **BETTER TOOLS FOR A BETTER DEBRIEF**
 - **KEEPING IT ALL TOGETHER**
 - **PAKISTAN AND ITS AIR FORCE**
 - **WORLDWIDE FLEETS**
 - **COMPANY PROFILES**
- AND MORE!**

The Warfighter's **ACE** Advantage

Test Any Armament System on Any Armed Platform



Downsize to One
Universal
Test Set



MTS-3060A SmartCan™

Globally Deployed, Combat Proven, Commercial

The **ACE** and Mission-Ready Airmen Enabler

- Rugged, handheld, powerful, rapid test
- Smart and legacy weapons systems support
- Reduced training and logistics footprint
- Eliminates multiple O-Level armament test sets
- Deployed on 14 platforms / 21 countries
- Commercial Item; OEM/USAF SERDed

The Marvin Group

MARVIN TEST SOLUTIONS



MARVINTEST.COM

© 2026 The Marvin Group. All rights reserved. Product and trade names are property of their respective companies.

READINESS REDEFINED

As of 2026, the maintenance, repair, and overhaul (MRO) landscape for fighter aircraft, particularly the ubiquitous F-16 Fighting Falcon, has entered a critical era, one focused on extending the life of aging airframes. With the average age of Western combat fleets at historic highs, MRO providers are navigating the “age penalty”—exponentially higher maintenance costs and structural degradation—by utilizing innovative sustainment technologies.

The F-16, with over 40 years in service, remains a cornerstone of global airpower, necessitating robust MRO support. The current standard is the F-16 Service Life Extension Program (SLEP), which extends the aircraft's life from 8,000 to 12,000 or more flight hours.

Much of this major overhaul involves structural enhancements, including replacing bulkheads and longerons to keep the jets flying until 2050. But the lifespan of F-16s and other fighter platforms is increasingly dependent on the integration of advanced, digitally driven sustainment methods. Meanwhile, the F-16 Systems Program Office is working on added software and other technological upgrades for this legacy fighter.

Similar, intense MRO efforts are being applied to other platforms. The F-15EX fleet is being certified for 15,000 flight hours, while the U.S. Navy and partners continue to maintain F/A-18 Hornets to bridge the gap to next-generation systems. Meanwhile, fifth-generation multirole fighters like the F-35 Lightning II are driving new maintenance requirements, such as specialized stealth coating repairs and software-intensive, data-forward maintenance pipelines.

In terms of predictive analytics, a major trend this year is the adoption of digital twins—virtual replicas of physical aircraft that utilize real-time sensor data to forecast health and structural fatigue issues. Instead of relying on scheduled maintenance intervals, condition-based monitoring enables technicians to identify specific areas of wear and predict the best time for MRO measures and take corrective action before components fail.

Furthermore, advanced non-destructive inspection (NDI) techniques and AI-driven robotics are being employed to check for corrosion and fatigue cracks. Plus, maintainers on base and in forward-operating theaters are increasingly experimenting with the on-demand part generation potential of 3D printing to address supply chain shortfalls.

Using these and other continually advancing processes, as part of a proactive approach to sustaining aging and new platforms alike, fleet operators are maximizing assets and enhancing operational efficiency. Optimizing MRO can prevent failures, reduce unscheduled maintenance, and improve fleet readiness by 20 percent, effectively serving as a force multiplier.

Today's defense landscape is characterized by a hybrid model, where older, modernized F-16s operate alongside new, advanced Viper Block 70/72 variants. In this context, the demand for MRO services is expanding, driven by increased operational readiness requirements in Europe and the Middle East, and exacerbated by high utilization in ongoing conflicts.

Plus, our industry faces another significant challenge: a global shortage of skilled personnel, with nearly 40 percent of technicians approaching retirement age. At the same time, the role of qualified aviation maintainers also is evolving from traditional mechanics to training in and knowledge of both mechanical systems and digital tools.

In 2026, keeping F-16s and other fighters flying is not merely about flightline maintenance and repair. It is about extending and supporting operational life through advanced engineering. The shift toward predictive, AI-driven sustainment is essential to mitigate the high costs of aging fleets, while achieving the high sortie rates required by global air forces. The successful application of digital technologies and training of a new generation of digital-savvy technicians undoubtedly will define the future of fighter aircraft MRO.

Richard Greenwald, Publisher
and HAL 9000

The Program Guide

F-16 & OTHER JETS 2026

PUBLISHER

Richard Greenwald

EDITOR

Laura Brengelman

GENERAL MANAGER

Rose Candido

TRAFFIC/PRODUCTION

Karen Duzy

CONTRIBUTORS

Jeff Blundell

Donna Kelly

Tracy Martin

Andrea Templeton

Pat Walsh

ADVERTISING

For more information,
please contact us at
914-244-8899

r.greenwald@abdonline.com

The Program Guide

- *F-16 & Other Jets*

A Publication of Wright Media, Inc.

P.O. Box 110382, Naples, FL 34108

P: 914-244-8899

www.wrightmediainc.com

r.greenwald@abdonline.com

The Program Guide - F-16 &

Other Jets, is published annually by

Wright Media, Inc. Periodicals

postage paid at Naples, FL and at

additional mailing offices.

Postmaster: Send address changes

to: *The Program Guide*, P.O. Box

110382, Naples, FL 34108

©2026. All rights reserved. No portion of this publication may be reproduced in whole or in part, in any way, without the express prior written approval of the publishers.

Printed outside the U.S.A.

This magazine is an independent publication of Wright Media, Inc. As such it is not affiliated with the F-16 TCG WWR show and is therefore able to maintain an independent perspective. All information contained within has been assembled from sources believed to be reliable, but we cannot accept any responsibility for inaccuracies. The inclusion of information by or about any company or contractor does not imply endorsement by the U.S. Air Force of that organization's products or services. Regarding any inaccuracies, or if you would like to be represented in the next Program Guide for this or other events in the industry, please contact r.greenwald@abdonline.com or call 914-244-8899. Thank you.

The Program Guide

F-16 & OTHER JETS 2026

“COVENANTS, WITHOUT THE SWORD, ARE BUT WORDS”
THOMAS HOBBS, 1651



6



12



22



18

CONTENTS

LETTER FROM THE PUBLISHER

Readiness Redefined
By Richard Greenwald

3

BETTER TOOLS FOR A BETTER DEBRIEF

Advanced technology helps fighter pilots and others analyze and learn from every flight
By Jeff Blundell

6

KEEPING IT ALL TOGETHER

Fasteners play an essential role in fighter aircraft
By Donna J. Kelly

12

NEW & NOTEWORTHY

Advances in Technology & the Supplier Base
By Andrea Templeton

18

COUNTRY SPOTLIGHT

Pakistan and Its Air Force
By Tracy Martin

22

LEGACY WORLDWIDE FIGHTERS 2026

By Tracy Martin

26

COMPANY PROFILES

Who, What and Where to Find Them

30

This magazine is an independent publication of Wright Media, Inc. As such it is not affiliated with the F-16 TCG WWR show and is therefore able to maintain an independent perspective. All information contained within has been assembled from sources believed to be reliable, but we cannot accept any responsibility for inaccuracies. The inclusion of information by or about any company or contractor does not imply endorsement by the U.S. Air Force of that organization's products or services. Regarding any inaccuracies, or if you would like to be represented in the next Program Guide for this or other events in the industry, please contact rgreenwald@abdonline.com or call 914-244-8899. Thank you.



DC-3/C-47

ONGOING
SUPPORT
COMMON
GOAL

- Manufactured Structural Components • Blankets • Plastics
- Rubber Seals & Gaskets • Sheet Metal Components
- Wiring Harnesses • Hinges
- Honeycomb Bonded Panels new and repairs
- Landing Gear Components • Cowlings



“A Reputation you Can DEFEND ON!”

Frazier Aviation, Inc. has more than 73 years of experience as a globally recognized manufacturer of high-quality, cost-effective aircraft spares. The company specializes in the machining and fabrication of large structural components, consumables, nacelle components, and specialty parts in full compliance with U.S. Government drawings, current Engineering Change Orders, and all applicable specifications. Frazier Aviation also operates an FAA-certified repair and overhaul facility.

- Global Leader in Military Spares
- Boeing (incl. Douglas/McDonnell Douglas) Partner since 1953 — PSID approved
- Northrop Grumman & General Dynamics Supplier since 1968
- Proven Performance on key U.S. Military Platforms: A-4, F-5, C-130, KC-10, P-3, F-15, F-16, F-18. Build to Print
- Navy CSI certified
- 99.8% QUALITY Rating over 30+ years
- FAA Cert #QN3R795L — Charles Taylor Award Winner
- AS9100 Rev. “D” registered, along with AS9120
- Quality Parts GUARANTEED
- Stocking Programs available
- MAPS — Military Aviation Program Sustainment

CERTIFICATIONS



KEY PARTNERS



YOUR AEROSPACE SOLUTION FOR OVER 73+ YEARS

BETTER TOOLS FOR A BETTER DEBRIEF

Advanced technology helps fighter pilots and others analyze and learn from every flight

By Jeff Blundell

There is a pivotal scene in the original *Top Gun* movie. The pilots are gathered in the briefing room, staring at a giant computer screen, where a recent training flight is being analyzed. Kelly McGillis's character Charlie is leading the debrief.

"Aircraft One performs a split S? That's the last thing you should do.... What were you thinking at this point?" she asks. Tom Cruise's character Maverick replies, "You don't have time to think up there. If you think, you're dead."

The importance of debriefing is a recurring theme in the film. Later, Tom Skerritt's character Viper advises Maverick, "A good pilot is compelled to

always evaluate what's happened so he can apply what he's learned."

But what about real debriefing sessions that real flight crews do? How much have those changed? Well, in some ways a lot. In other ways, not at all.

HOW TO TEACH, AND HOW TO LEARN

U.S. Air Force Major John Pierce is with the 559th Flying Training Squadron in Texas. He serves as an instructor for future instructors.

"I am teaching the people who are already winged aviators who have flown other aircraft, either fighter pilots or cargo pilots," says Pierce. "After their

Pilots such as U.S. Air Force Captain Aimee Fiedler of the F-16 Viper Demonstration Team make extensive use of the debrief process to improve after flight. (Photo by Staff Sergeant Madeline Herzog, courtesy of the U.S. Air Force.)



The intent remains the same, but the technology used in debriefing has advanced greatly since the movie *Top Gun* came out in 1986. (Image created by AI.)

first or second assignment, they are told they're going to go teach in pilot training. They come here to Randolph Air Force Base, and then we give them the skills for how to teach."

Debriefing is a crucial part of that process. According to Pierce, "The debrief is where all the connections happen to help construct your knowledge." But those connections only happen if you approach the debrief with the right philosophy. That requires incorporating both the good and bad things that happen during a flight.

Pierce explains, "Have you ever had a good day out of nowhere? And at the same time, have you had a bad day? Well, in a learning environment, it's pretty natural to focus on the bad day and fix what went wrong. Because we don't want to have that happen again, right?"

"What we do is, after a good day, we try to figure out what went right. And understand if it was a lucky mistake, or thanks to a learned competency. If you take the time to find the root cause, analyze it, and figure out why it worked, you have a better chance of repeating it in the future."

Obviously, the debrief process needs to correct mistakes. Yet Pierce says he has seen pilots learn just as much from their successes as from their failures. "I flew with somebody who was struggling mightily in formation and could not figure out how to fly the maneuver we were doing. And in the moment, I was able to use a coaching technique that worked."

"That was the first time the student was ever able to accomplish it," he recalls. "Once we got down on the

ground, we took the time to describe in detail what had happened: both what he was seeing and what was happening in reality. We were able to put down on paper what worked. After that, for the rest of the program, it was never an issue."

Pierce brings up an important point. What a pilot perceives to be happening, versus what is actually going on, may be different. Clearly, it is hard to learn if you and your instructor disagree on what happened. Part of the solution is what Pierce calls "creating a shared mental model."

"If you're in a formation, or if you're in a complex environment, what you see may not be the whole puzzle. You may only know what happened in your environment," he notes. "It will take the recollection of data from everyone else who was around you to get a true picture of what happened." That's where flight recording technology from CALCULEX can come into play.



Major John Pierce is an instructor with the 559th Flying Training Squadron in Texas. (Courtesy of the U.S. Air Force.)

U.S. Air Force Captain Quincy Watts, of the 510th Fighter Squadron sits in his F-16 Fighting Falcon before takeoff. (Photo by Technical Sergeant Stephanie Longoria, courtesy of the U.S. Air Force.)



SrA William Culbreath
SrA John Hensley



The 559th Flying Training Squadron is based at Randolph Air Force Base in Texas. They use the T-6A Texan II as a training aircraft. (Photo by Master Sergeant David Richards, courtesy of the U.S. Air Force.)



A modern fighter aircraft is equipped with a broad array of sensors to help the pilot during a mission. The data is also collected and used in post-flight debriefing. (Photo by Airman 1st Class Trevor Calvert, courtesy of the U.S. Air Force.)



U.S. Air Force Lieutenant Colonel Tyler Brummer, a 480th Fighter Squadron F-16 Fighting Falcon pilot, prepares for takeoff. (Photo by Senior Airman Demi M. Ebert, courtesy of the U.S. Air Force.)

WHERE AM I?

"Pilots used to talk, standing in front of a crowd, and they'd have their hands up, showing how they turned this way, and that guy turned that way," says Tom Wyzgowski, Director of Engineering and Advanced Programs at CALCULEX. "That acting out of the mission isn't really needed anymore, because we have all the information digitally. For example, if you have two fighters flying a training mission against two other fighters, they can all come in and grab their media and share it." What they grab is their RMM, or removable memory module.

"The removable memory modules go in what we call a 'toaster.' Or they can be plugged into the computer directly with a firewire," he says. "Everyone's flight time is aligned, and they play all the videos up on these huge screens, with each aircraft identified by a circle — a ring around them identifying the first aircraft, second aircraft, third aircraft, fourth aircraft. Then, they have a big moving map display, and it shows these aircraft in position to each other." It is a graphic display that Tom Cruise's character would have been jealous of in 1986.

There is video from the heads-up display (HUD) systems of each pilot, as well as an over-the-shoulder view, plus an angle that is shown as if you were flying above the formation. The CALCULEX system also records and relates speed, direction, location, and orientation, basically everything you would want to know about the aircraft's movements. The information from each aircraft is combined to create a holistic picture of the mission.

"The beauty of it is everybody gets to see everybody else's video all at the same time. There's no more saying, 'See, I saw you in my sight here.' The pilots can look at each other's displays. They can see where they were in relation to each other, and who was turning which way. Then, they can stop it at any point, and discuss where they were in the mission."

This technology does not only look cool, it streamlines the mission analysis and learning process. "In the old days, when they had videos, they would record them on high eight, or VHS tapes," recalls Wyzgowski. "A lot of training time was spent getting the tapes all loaded and hitting play on them all at the same time, so they were in sync."

"Now, pilots can do it five minutes after they hit the room. All they have to do is put the cartridges in the toaster and hit play." Wyzgowski continues, "They're not having to worry about display issues. They can focus on, 'Did I do right in the air to make a good shot on my opponent? Or did I do right on defending myself from whatever?' So, training is much more effective."

Modern fighter jets already carry a lot of data recording equipment, but there are ways to



DATA COLLECTION DURING FLIGHT TESTS

It is not just the pilots who learn from on-board data acquisition. There is a need for technology that collects and transmits technical flight data in real time.

"At DTS (Diversified Technical Systems), we focus primarily on analog sensor measurements. That's vibration, shock, temperature, voltage, strain loads, things of that nature," says Huy Nguyen, Sales Manager and Engineer at DTS Aerospace & Defense, based in Seal Beach, California.

The DTS team started by collecting data for automobile manufacturers. They would put sensors in cars that were crashed into a wall to measure effects of the impact. While no one in the aircraft industry is interested in crashing planes just to see how destructive that is, it is important to know as much as possible about what is happening on board during a test flight.

"We made miniature data acquisition systems," explains Nguyen, "and we asked ourselves, 'How can the flight test market take advantage of what these systems do?'"

The company's first aviation customer was a helicopter manufacturer. "They were developing a new type of rotor that was moving away from hydraulics toward electromechanical control of blade pitch," recalls Nguyen. "Their traditional way of measuring the changes was to put strain gauges on the rotor. They would install a slip ring and transmit power to the sensors, and then also take that signal for the sensors and transmit it back down through these slip rings."

The problem was the approach suffered from electronic interference, and the data collected was "too noisy." DTS designed a small, self-contained box, about half the size of a cell phone that attached to the base of each blade, then collected and wirelessly transmitted the data.

Around the same time, DTS solved a problem for the U.S. Air Force, which was testing modifications on F-16s. "When they do these revisions," says Nguyen, "they have to take the aircraft apart. They add more sensors, and that means more cable runs, and more changes to the platform. That's time, that's effort, that's money."

DTS came up with a product called the Slice6 Air, an independent module that is easy to install (and remove) and does not interfere with the rest of the airplane's systems. Because this relatively inexpensive module transmits wirelessly in real time, it also can be used on munitions and drones destroyed in the testing process.

"Temperature is a big thing right now, because of the interest in understanding what's happening on board aircraft at hypersonic speeds. We're subjecting materials and systems to speeds and temperatures that are on the cutting edge of what's possible," says Nguyen. Knowing more about what happens at those limits empowers engineers testing and developing the next generation of fighters.

Weighing just 50 grams and half the size of a cell phone, the SLICE6 AIR is small enough so as not to cause unintended changes to the properties of the test article. (Image courtesy of DTS.)



The SLICE6 AIR is small, light, and robust enough to be mounted on the base of helicopter blades. (Image courtesy of DTS.)



SIMPLE ANSWERS TO IMPORTANT QUESTIONS



These screen shots show the breadth of information available to a pilot after their flight through the CloudAhoy app. (Images courtesy of Chuck Shavit.)



Chuck Shavit was 50 years old when he started flying. “It was a mid-life thing. He had just sold a company, and we had some time and money,” recalls his wife and business partner Tani Shavit. “He was thinking, ‘What should I do next?’ He always wanted to learn how to fly. So, he did.”

Like most students, Shavit found the cockpit to be a busy and confusing place. Debriefing after a training flight was a chance to recall and process what had happened. But he frequently found that his head was spinning, with all that was going on along with information from the instructor, making it hard to piece it together. Plus, both his and the instructor’s interpretations of what had happened were subjective and thus open to different interpretations.

Together, the Shavits decided to build an app. Chuck started bringing his iPhone on flights and recording his location and speed using the internal GPS. He started playing back each flight against a simulated backdrop, adding new features to see different things.

They called it and made it available as a free app for a few years. In 2013, they released a subscription version. Mostly, CloudAhoy is used to debrief students after instructional flights. It helps fill in the gaps between what they remember and what actually happened up there. By saving historical data, pilots in training also can keep track of their development, comparing flights from months ago to today’s. The app even gives each flight a grade to track improvement.

In 2018, the Shavits were contacted by the U.S. Air Force to be part of Pilot Training Next (PTN), a program initiated by the Secretary of the U.S. Air Force to improve pilot training. What they found was that pilots in fighter jets can benefit from the same tools beginners do. Having an objective report of their flights to consider during debriefing can help identify bad habits they did not even know they had.

Such a record also can assist a pilot in better understanding what happened following a dangerous incident. That was the case for a CloudAhoy employee after a test flight.

“She was flying a Cessna she was not used to. Accidentally, she cut off the fuel and started to lose altitude,” recalls Shavit. “At the time, there was a lot going on. But sitting in the office afterwards, she was able to watch what happened on CloudAhoy and ask herself some hard questions: How did she handle it? How was she gliding? How did she recover? What could she have done differently?”

Those kinds of questions are central to every pilot’s debriefing, whether it is looking back on a smooth flight on a sunny afternoon or a critical mission in enemy territory.



A pair of F-16 Fighting Falcons from the 148th Fighter Wing deploy flares over Duluth, Minnesota. Even when in close proximity and in constant communication, pilots often perceive situations differently. Adding technology to the debrief process helps create a shared mental picture. (Photo by Senior Airman Addie Peterson, courtesy of the U.S. Air National Guard.)

improve how that information is stored and visualized. “Our recorders are pretty powerful tools. They’re not just places where all the data comes in as bits and just goes to rest until they land. They are smart enough to screen and only show the data that’s appropriate for the air crews, and they can do this pre-processing and provide feedback to air crews while still in flight,” says Wyzgowski.

This allows crew members flying on a B-52 fitted with the CALCULEX recording system to review their mission on the flight home. The navigators and bombardiers can gather around their laptops and evaluate their actions using immediately available data.

“They can say, ‘Okay, here’s exactly where I was when I dropped. And here’s what I should have done to take out that target.’ It helps them to learn and get better right away,” notes Wyzgowski. “Doing this while still in flight also helps, because by the time you get home from a long mission, you just want to go home and sleep.”

OTHER USERS

It is not just pilots who benefit from collecting and debriefing with all this data, manufacturers have started using it as well. “There were F-15s that, when they were

flying long-duration missions, would sometimes drop out of autopilot,” says Wyzgowski.

This was one of those problems that happened intermittently, so diagnosing it could have taken multiple long-distance test flights. That’s a lot of time, fuel, and expense. Instead, CALCULEX collected flight data from the recorders on existing planes.

“When the pilots had reported that they had an issue where the plane dropped out of autopilot, the video and flight data was pulled for that time period. CALCULEX sent that data slice, not the whole recording—just a few minutes before to a few minutes after—to Boeing,” says Wyzgowski. “Based on that information, Boeing found the error, made a change to their software, and cleared it up.”

Debriefing with the full spectrum of data is even more critical when you are firing live weapons. “If anybody is up flying, and they shoot a missile, and it doesn’t come off the wing, or comes off the wing but doesn’t hit what it’s supposed to, or has an issue of any sort, all the air crew has to do is say, ‘I had an issue at this time,’ and they can take that slice,” says Wyzgowski.

“So, no more where guys say, ‘Oh, I was shooting an A-9. And it just went off into the sun.’ And everybody goes, ‘Really? Was

it the airplane? Was it the missile? Was everything done right before it was launched?’ There is none of that. Now, everybody has the data, so there’s no more guessing or finger pointing.” He concludes, “That’s the beauty of these recorders being on every aircraft.”

EVER BETTER

All that information also is collected, filtered, and presented to make the next generation of pilots the best they can be. While there have been outstanding instructors in the U.S. Air Force for a long time, modern teachers now have access to a whole new suite of tools.

As Major Jon Pierce notes, “It’s all about figuring out how you help somebody really kickstart the construction of knowledge in their brain. We’ve spent a lot of time and effort working with cognitive coaches, civilians called in to help because they’re experts in the field. It’s just like professional athletes working on their cognitive skills. We use the best science available to develop the human brain to make every pilot better.” And that all starts with a better debriefing process.



KEEPING IT ALL TOGETHER

Fasteners play an essential role in fighter aircraft

By Donna J. Kelly



Exploding bolts. Pins and screws that shear. Fasteners designed to fail. While some of these seeming calamities are intentional, the majority are not. Aircraft fasteners are engineered to do a specific job, in a specific location, within specified limits. Luckily, the majority of aircraft fasteners holding together the state-of-the-art Lockheed Martin F-16V Viper do not disintegrate—that is, if the aircraft’s mission does not exceed its structural limitations.

Screws, rivets, and bolts are the mechanisms that hold together the materials that make up a plane. And the companies that make various fasteners must employ rigorous quality controls and standardized procedures to ensure their products stand up to the stress, strain, load, and vibration of supersonic aerodynamic flight with high-load maneuvers.

Powerful forces act on any aircraft in flight, but more so on supersonic fighters. Beside the four major forces of lift, weight, thrust, and drag, other extreme stresses try to deform the jet in flight. These include tension (a force that tries to pull the aircraft apart), compression (a squeezing force that can crush a

structure), torsion (a twisting force that causes part rotation), and shear (a force acting parallel to the airframe that can make one fixed layer slide over another). So how do today’s fasteners resist these forces and hold the Viper together?

VIBRATION IS A MAJOR ISSUE

Aircraft vibration is a constant and ongoing physical condition for aircraft with running engines. This inescapable force creates tiny, repetitive movements that affect every part of the airplane, including fasteners such as bolts and screws.

All fasteners used on the F-16 must be properly torqued. That is, the bolt or screw is twisted with force, until it is tightened to an amount specified in the technical manual. This number may be given in Newton meters (N-m), foot pounds (ft-lb), or inch pounds (in-lb). If a fastener is not torqued correctly, vibrations will cause it to loosen over time. Even when tightened sufficiently, things happen, so fasteners on fighter jets commonly employ self-locking mechanisms.

U.S. Air Force F-16 maintainers use military-standard (MS) and National

National Aerospace Standard (NAS) parts are designed and approved to meet the demands of intensive mission-critical applications, including defense aircraft and weapons systems. (Image courtesy of MW Components.)



Airman 1st Class Bradley Giroux uses an air drill to remove a Davis Elliptical fastener from an F-16 Fighting Falcon at Balad Air Base, Iraq. The fastener is used as an internal nut plate — individual nuts are not needed to hold bolts and screws in place. (Photo by Staff Sergeant Joshua Garcia, courtesy of the U.S. Air Force.)

Aerospace Standard (NAS) self-locking fasteners to overcome extreme vibration and keep bolts and screws in place. These special self-locking nuts incorporate various types of internal features that secure the bolt in place and prevent turning due to vibration. Some have nylon inserts that squeeze or deform onto the threads of the bolt or screw to provide friction to hold it in place. Ideal for use in low-heat applications, nylon inserts will melt at temperatures above about 250 degrees Fahrenheit.

For hotter areas, all-metal locknuts are used. The MS21042 (superseded by NASM21042) series of all-metal, reduced-hexagon, self-locking nuts are widely employed on the F-16. Able to withstand temperatures up to 800 degrees Fahrenheit, metal locknuts are designed to deform in different ways to secure bolts. For example, some have internal threads that become distorted or crimped at the middle or top and press against the bolt when tightened to create the friction needed to lock it in position.

Vibration-resistant locknuts are used to secure control pulleys, engine bearings, and panels, just to name a few. While all-metal nuts may be reused up to fifteen times if not damaged, nylon nut-plates are onetime-use only items.

Bristol Industries of La Brea, California, a division of Consolidated Aerospace Manufacturing (CAM), is a worldwide leader in the design and manufacture of such specialized self-locking nuts and fastener systems, as well as other key parts and fittings. Bristol’s products are made with specialized polymers, high-strength metals, and temperature-resistant superalloys such as Inconel, Waspaloy, and multiphase alloys.

THE LIFE OF THREADED BOLTS

A threaded bolt’s life has two stages: When the bolt can withstand the high loads put upon it, it is considered to be in the elastic phase. When over-stressed, it assumes the state of plastic deformation and will be permanently distorted.

MATERIALS MATTER

To stand up to the rigors of supersonic flight, Bristol Industries and other manufacturers of fasteners for defense aircraft use a variety of highly specialized materials, including:

- **Inconel** is a corrosion-resistant, nickel-chromium superalloy with exceptional strength that is able to withstand extreme temperatures.
- **Waspaloy** is a nickel-based superalloy known for exceptional mechanical properties and oxidation resistance at temperatures up to 1600 degrees Fahrenheit.
- **Multiphase alloys** are materials engineered with two or more distinct metallic phases (microstructures) at the same time to achieve added, synergistic properties.

An example of a multiphase alloy is Ti-6Al-4V (Titanium Alloy). Offering superior performance over commercially pure titanium, this two-phase alloy is made up of approximately 6 percent aluminum and 4 percent vanadium. Joining substantial portions of both the F-15’s and F-16’s structures, it can be found in fuselage components, engine compressor parts or casings, wing spars, ribs, and landing gear.

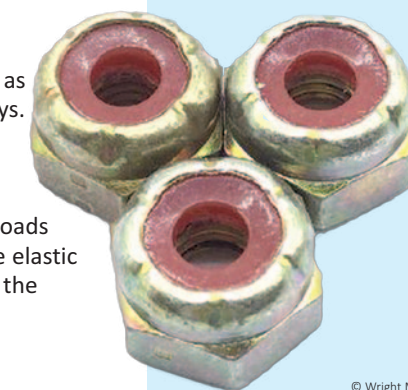

Commonly used in areas where temperatures do not exceed 250 degrees Fahrenheit, locknuts with nylon inserts are designed to deform and squeeze around the bolt, locking it in place. (Image courtesy of Wurth USA.)

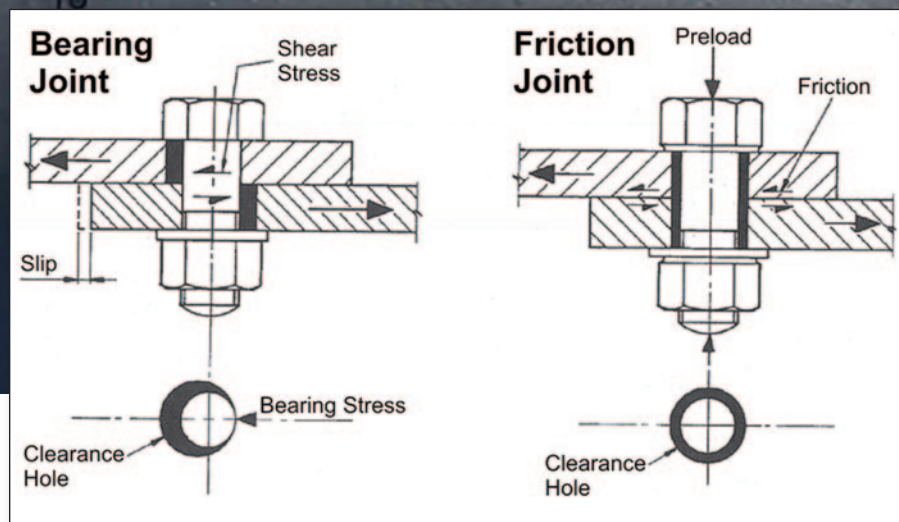
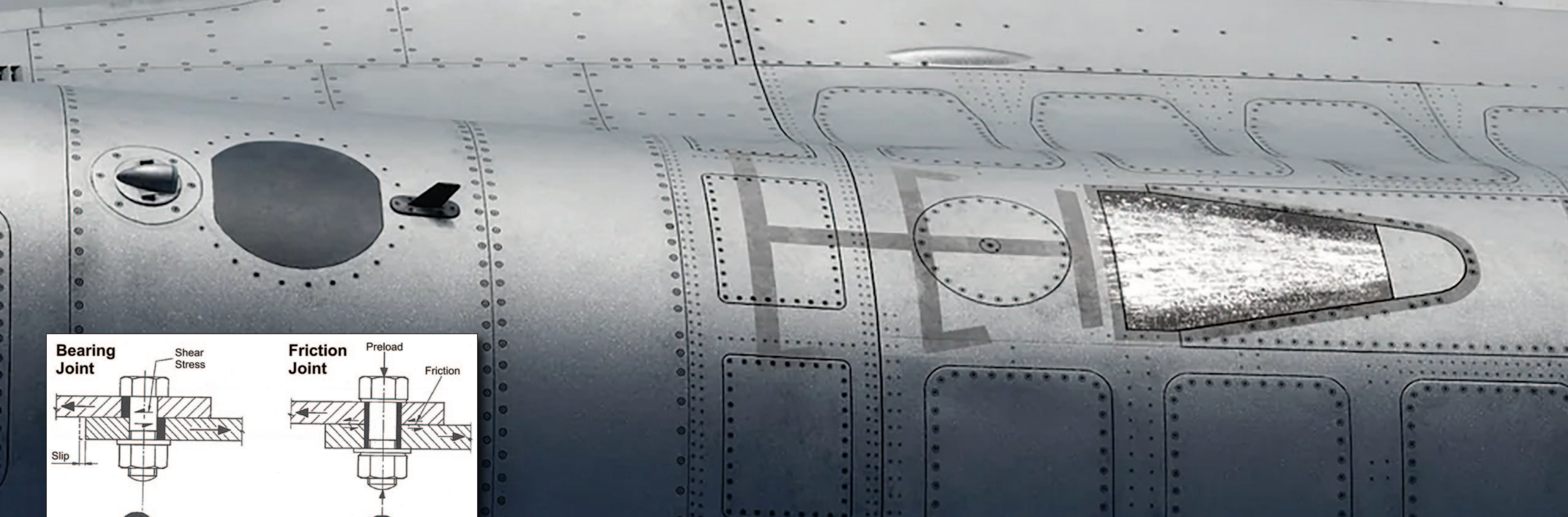

Shear planes in bolts are the critical surfaces, where a bolt is subjected to forces trying to slice it apart due to lateral movement. Occurring at the interfaces between connected members, they affect the bolt's strength, requiring designers to calculate force per plane to prevent failure. (Credit: T. Bart Quimby, PE., Ph.D., author of A Beginner's Guide to the Steel Construction Manual, 13th Edition, © 2006, 2007, 2008, www.bgstructuralengineering.com.)

When a bolt is installed on aircraft, it becomes embedded in the structure of plane. Consequently, when flying, the bolt moves within its drilled hole and in conjunction with its fastener located on the opposite side. If not securely fastened, the bolt will attempt to twist out due to torsion.

In addition, the threads of the bolt act as a heavy spring, serving as a malleable inclined plane that allows it to stretch under tensile loads and strain with compression. Therefore, it also needs to be strong on the shear plane, meaning that its composition must be sufficient to resist shear forces acting on it from 90-degree angles.

BOLTS DESIGNED TO RELEASE

Shear bolts and pins act much like a mechanical fuse, in that they are designed to break under a specific amount of stress. Intended to fail before other more critical systems, shear bolts and pins generally are made from a lower strength steel than the main attachment bolts around them.

For instance, a shear pin installed in the F-16's arresting gear system breaks when the

hook is deployed. Another tail hook shear bolt acts as a limiting device that allows the approaching aircraft to catch the arresting cable at an angle, but not too much of an angle. If the jet approaches off-center, the tail hook will swivel enough to catch the cable. If the angle is too great, the bolt will shear.

Explosive bolts are used where the pilot needs to eject something or someone off or out of the aircraft. A Canopy Actuator Release Bolt (CARB) is an explosive bolt situated where the canopy torque tube connects to the actuator. When the pilot begins the ejection sequence, an electrical signal initiates an internal charge that detonates and severs a "ridge-cut" weak spot in the bolt, breaking it and releasing the canopy.

Among top manufacturers producing explosive bolts and shear pins for single-seat models of the F-16 is Parker Meggitt Safety Systems, of Simi Valley, California. CIRCOR Aerospace, of Corona, California, supplies CARB bolts for two-seater F-16s.

COMPOSITES COMPLICATED BY LIGHTNING STRIKES

Many aircraft parts are now being constructed using composite materials. A number of the F-16's critical flight controls, including the horizontal stabilizers, vertical fin and rudder,

and the ventral fins are made with advanced, lightweight composites.

Non-metal composites offer numerous structural advantages but are particularly vulnerable to lightning strikes. The reason is that materials used in standard composites do not lead the lightning's powerful electrons to flow away from the impact site, resulting in burnt holes, singes, or other serious damage.

To combat this problem, composites used for aircraft applications often include some sort of embedded metal mesh. Alternatively, added films like Electroglide, made by Park Aerospace Corporation, of Newton, Kansas, create a conductive surface that effectively transfers lightning's energy along a safe path to minimize damage.

But what about the metal fasteners holding these critical structures in place? Lightning can cause tiny high-voltage arcs to shoot between the fasteners and composite structures, causing damage such as resin vaporization, fiber breakage, delamination, and voids. Plus, sparking is never good in any area where there may be fuel vapors that can easily ignite.

To address this problem, Howmet Aerospace, of Pittsburgh, Pennsylvania, makes a type of metal fastener called Flite-Tite for use on parts that involve metal fasteners in composite surfaces. Flite-Tite fasteners are

constructed with a titanium or steel sleeve that precludes gaps between the composite airframe part and its metal fasteners. The special fasteners prevent serious damage to the composite skin around them by enabling electrical current to discharge from the aircraft without significant detrimental effects.

A SQUEEZABLE FASTENER

We have examined only a tiny portion of the immense variety of aircraft fasteners, but the all-important rivet must not be overlooked. Unlike screws or bolts, rivets are squeezed into place and do not move within their drilled holes.

Rivets are found all over the F-16. Thousands hold the aircraft skin to the fuselage, most flush for aerodynamic reasons, such as achieving and maintaining smooth laminar flow. These fasteners are known as brazier head or flush rivets.

Solid rivets or round head rivets are found in high-stress areas like wing attachments.

This view of the top of an F-16 clearly shows some of the thousands of rivets found on this fighter jet. (Image courtesy of Reddit.com.)

Flite-Tite fasteners made by Howmet Aerospace offer lightning strike protection on carbon fiber-reinforced aircraft. (Image courtesy of Howmet Aerospace.)





NOT JUST ANOTHER TIE

Vibration also causes chafing, leading to any number of possible system failures. For example, large bundles of wire found in places like the wheel well are secured together to keep them in place and prevent them from rubbing or chafing against another surface (like the edge of a metal bulkhead), which can cause the protective coverings to wear off and expose live wires.

In the past, wire bundles were tied with waxed, braided string, or lacing cord, and then secured with specific knots like a clove hitch. Another method uses cable ties made of strong, pliant plastic. Unfortunately, both methods present significant ergonomic, consistency, and safety risks.

Hand-tying laces often causes fatigue and repetitive motion injuries, leading to varying tension being applied to the wrapping as an operator's shift

LaceLok Cable Lacing Fasteners, made by Daniels Manufacturing Corporation (DMC), are well designed to replace hand-tied lacing tape and cable ties for secondary support of wire harnesses. Made of aerospace-grade materials, LaceLok features a small, rounded fastener and meta-aramid fiber lace that provide superior resistance to fuel, other chemicals, abrasion, and extreme operating conditions. (Image courtesy of DMC.)

progresses. Plastic bundle ties are problematic due to hard, sharp edges that can damage adjacent cables. When the ends of the ties are cut, the sharp, pointy edges can slice maintainers' hands and other surfaces. And plastic cable ties tend to be vulnerable to corrosion and wear caused by chemicals, temperature fluctuations, and other conditions. As a result, plastic zip ties are prohibited by technical orders and manuals for most end users, except for approved OEM uses.

As a solution, Daniels Manufacturing Corporation (DMC), Orlando, Florida has developed a product that replaces hand-tied strings and plastic ties. LaceLok is made from the same Nomex lacing tape used in hand-tied laces. The Nomex lace is attached by aramid fiber threads to an ultra-high-temperature thermoplastic head that is fastened using the custom LaceLok Installation Tool.

LaceLok's fastener head can withstand extreme temperatures from -76 to 500 degrees Fahrenheit, and it is resistant to hydraulic fluid, jet fuel, lubricating oil, and isopropyl alcohol. Offered in various lengths from 6 to 24 inches, LaceLok can be wrapped once, twice, or three times around wire bundles to provide tensile strengths of 55 to 165 pounds.

Benjamin Sklenar, Government Sales Manager for DMC states, "LaceLok is one of our newest innovations and truly a game-changer in secondary wire harness support. It offers a superior alternative to traditional hand ties by reducing maintainer strain and replacing an outdated method with a consistent, repeatable tooling solution." He also points out that the locking system is ideal for "fastening fiber optic cables to prevent overtightening that could lead to signal degradation."

Another product from DMC is the Safe-T-Cable, a fastener retention system designed for securing fasteners in critical areas subject to foreign object damage (FOD). Safe-T-Cable is designed to withstand corrosion and heat up to 1500 degrees Fahrenheit. According to Sklenar, "Safe-T-Cable significantly reduces installation time for maintainers and eliminates potential failures caused by work-hardened lock wire, ensuring both efficiency and reliability. This is obviously critical for fighter aircraft when you start talking about high G maneuvers."



Round rivets are most common. (You can see larger versions of this type when you look at the big rivets holding a bridge or other large metal structure together.) Other types include blind rivets (also known as pop rivets), tubular and semi-tubular rivets, split and bifurcated rivets, and rivets that self-pierce to reduce the tools and labor needed for installation.

Some rivets can be installed by one person. Others need two people: one to shoot the rivet with a pneumatic hammer, and the other to hold the "bucking bar" on the opposite side.

CONSISTENCY COUNTS

Of course, all fasteners require some kind of fastening tools, and the U.S. Air Tool Company (USATCO) of Ronkonkoma, New York, manufactures, modifies, repairs, and supplies many of the tools used by the major U.S. Air Force materiel commands at Hill Air Force Base in Ogden, Utah; Tinker Air Force Base, Oklahoma City, Oklahoma; and Wright-Patterson Air Force Base in Dayton, Ohio.



Gerry McGuire, Sales Manager for USATCO says that they "sell lots of tools that squeeze" to install all types of rivets. Other tools involved in the process of joining metal include tools for hole cutting, sheet metal tools, and sealants. USATCO even sells its own brand of safety wire pliers, along with different thicknesses and grades of wire.

USATCO uses only certified stock metals for the fabrication of their tools. Each shipment of metal comes with its own Certificate of Conformity from the manufacturer, verifying that the metals meet all engineering specifications. And consistency in fastener construction, tooling, and installation is what it is all about.

UNSUNG HEROES

The supersonic Lockheed Martin F-16 is a bird that must keep all of her fins and feathers firmly attached as she screams through the sky, performing wrenching movements that would stress, bend, and deform the aircraft's skin and underlying components if not securely attached. Thanks to the countless thousands of unsung heroes on each plane, namely aircraft

fasteners of all types, the Viper can hold together during these death-defying maneuvers to achieve air superiority in the battlefields of the sky.

Sources

Bristol Industries, La Brea, California, www.camaerospace.com/bristol

CIRCOR Aerospace, Corona, California, aerospace.circor.com

Daniels Manufacturing Corporation (DMC), Orlando, Florida, www.dmctools.com

Davis Fasteners, Bolingbrook, IL, davisfasteners.com

Howmet Aerospace, Pittsburgh, Pennsylvania, www.howmet.com

Military Fasteners, West Melbourne, Florida, military-fasteners.com

MW Components, Charlotte, North Carolina, www.mwcomponents.com

Park Aerospace Corporation, Newton, Kansas, parkaerospace.com

Parker Meggitt Safety Systems, Simi Valley, California, www.meggitt.com

U.S. Air Tool Company (USATCO), Ronkonkoma, New York, www.store.usatco.com

Wurth USA, www.wurthusa.com

USATCO is an official repair station for Cherry Textron, Chicago Pneumatic, and Cooper Power Tools (including Dotco, Gardner Denver, Buckeye, and Doler) and repairs other major brand pneumatic tools. In addition, USATCO manufactures parts and performs necessary tool modification. (Image courtesy of Gerry McGuire/USATCO.)

ADVANCES IN TECHNOLOGY & THE SUPPLIER BASE

By Andrea Templeton

The F-16 Worldwide Review, held annually in Ogden, Utah, has long served as a crossroads for the aviation defense world. It is a meeting point for military operators, program managers, and the companies that keep their aircraft flying. Here, stakeholders compare notes, exchange intelligence, and look ahead to future requirements.

The General Dynamics F-16 Fighting Falcon, now produced by Lockheed Martin—with more than four decades in service and still one of the most widely operated fighter aircraft in the world—continues to anchor a robust, competitive, global supplier base. As nations from Bulgaria to Poland to the Philippines pursue new acquisitions of or upgrades to the latest Viper standard, aftermarket demand continues to grow.

For this publication, we reached out to leading companies across the defense aviation ecosystem to learn about recent developments at their firms. Whether you are attending the show in person or following it from afar, the information presented below offers a snapshot of key innovations across the defense aviation supplier base. Coverage extends beyond the F-16 to include platforms such as the McDonnell Douglas/Boeing F-15 Eagle, the Lockheed Martin F-22 Raptor, and the Lockheed Martin F-35 Lightning II, as well as a range of rotorcraft and unmanned systems.



AAR—MRO & REPAIR DIVISION

Headquarters: Hauppauge, New York (with facilities in San Marcos, Texas; Cadillac, Michigan; and Amsterdam, Netherlands)
Website: aarcorp.com



A technician works on the MRO floor at AAR Corp.'s Amsterdam facility, where technicians support aircraft maintenance and overhaul operations. The company has been expanding its service offerings, enhancing its capabilities, and extending its reach through key acquisitions. (Image courtesy of AAR Corp.)

AAR Corp., with more than seven decades of aviation service experience, is actively expanding its legacy through strategic growth. Two relatively recent acquisitions reinforce AAR's position as a leading independent maintenance, repair, and overhaul (MRO) provider and highlight this well-known aviation aftermarket company's dedication to providing comprehensive service offerings.

The Repair & Engineering segment, which provides airframe maintenance and component repair services to commercial and defense customers, saw a major boost following the \$725 million acquisition of the Triumph Group's Product Support business in March 2024. This transaction integrated five specialized MRO facilities into AAR's global network, broadening its direct offerings to encompass approximately 10,000 additional part numbers. In addition, the acquired locations—two in Texas, one in Kansas, one in Arkansas, and one in Chonburi, Thailand—extended AAR's international footprint and reinforced its position in the rapidly growing Asia-Pacific MRO market.

This past December, AAR further strengthened its service portfolio by agreeing to acquire Aircraft Reconfig Technologies, a Federal Aviation Administration Organization Designation Authorization (ODA) holder specializing in interior engineering and certification of aircraft, for \$35 million. This acquisition enhances AAR's in-house design and certification capabilities, streamlining approval processes for complex modification projects and reducing dependence on external providers.

AAR—PRODUCT SALES DIVISION

Headquarters: Wood Dale, Illinois
Website: aarcorp.com



AAR Corp.'s global warehouse management and distribution operations support its Parts Supply segment in sourcing and distributing aircraft components worldwide for commercial and defense customers. (Image courtesy of AAR Corp.)

AAR Corp.'s Parts Supply segment, headquartered at the company's Wood Dale, Illinois, campus, serves as a global distribution arm for a wide range of aircraft components and consumables. Earlier this year, AAR began executing a distribution agreement with the Triumph Group, covering its commercial actuation product line supporting Boeing and Airbus platforms. The partnership leverages AAR's established sales channels and logistics infrastructure to improve product availability and streamline delivery for various MRO customers.

On the defense side, the Parts Supply segment supports legacy fighters, including the F-16. With operations spanning more than twenty countries and an extensive supplier base, the division is instrumental in sourcing hard-to-find components as aging aircraft remain in service longer and sustainment requirements intensify.

BAE SYSTEMS

Headquarters (U.S.): Falls Church, Virginia
Website: baesystems.com



Under a recent U.S. Air Force contract, BAE Systems supports sustainment services for F-16 avionics diagnostic systems, supporting operations across twenty-two partner nations. BAE also is developing advanced features of precision munitions for F-16s and other fighter platforms to counter unmanned and other aerial threats. (U.S. Air Force photo by Staff Sergeant Tryphena Mayhugh.)

BAE Systems remains one of the F-16's most deeply embedded sustainment partners, supporting avionics, advanced electronics, and survivability systems across the global fleet. The company's trademarked Intrepid Shield system integrates sensors, electronic warfare capabilities, and countermeasures to enhance platform survivability in contested environments.

In February, the U.S. Air Force Sustainment Center awarded BAE Systems Information and Electronic Systems Integration in San Diego, California, an 11-year indefinite-delivery/indefinite-quantity contract valued at up to \$98.9 million. The agreement covers sustainment engineering services for F-16 avionics intermediate shop automatic test equipment across twenty-two partner nation fleets. The depot-level diagnostic systems are used to test and repair avionics components pulled from the aircraft, preserving the operational capability of fielded systems and related sustainment components.

Also in February, the U.S. Air Force awarded BAE Systems a \$145 million sole-source contract to develop and integrate enhanced capabilities for the Advanced Precision Kill Weapon System (APKWS). This contract includes dual-mode guidance concepts designed to counter unmanned aerial threats, with integration planned across F-16 and other fighter platforms.

Previously in December, the U.S. Navy awarded BAE Systems an APKWS production contract involving both U.S. armed services and foreign military sales customers. Valued at up to \$1.7 billion over five years, this agreement reflects the strong global demand for cost-effective precision munitions.



The Gen III Helmet-Mounted Display System, developed by Collins Elbit Vision Systems (CVS) for the F-35 Joint Strike Fighter, integrates flight data, targeting, and situational awareness directly into the pilot's visor. Through its joint venture with Collins Aerospace, CVS has delivered more than 3,000 systems. A sixth-generation version, tailored to meet U.S. Navy requirements, recently completed a Critical Design Review. (Photo courtesy of DVIDS.)

ELBIT SYSTEMS OF AMERICA

Headquarters: Fort Worth, Texas
Website: elbitamerica.com

Elbit Systems of America is advancing on two fronts with direct implications for the F-16 and next-generation fighter cockpits: upgrading heads-up displays for the U.S. Air Force's F-16 Block 40/42 aircraft, and developing a sixth-generation helmet-mounted display system for U.S. Navy fighters.

On the F-16 side, the company was awarded an indefinite delivery/indefinite quantity (IDIQ) contract in 2024, with a ceiling of up to \$89 million, to supply Wide-Angle Conventional Heads-Up Display (WACHUD) replacements for the U.S. Air Force's F-16 Block 40/42s. The first order, valued at more than \$57.5 million, was received in September of that year, with deliveries scheduled through 2027. The WACHUD system replaces legacy heads-up displays, projecting critical flight data over a wider field of view. According to Jimmy Johns, Vice President of Operations, Elbit has supported the majority of the F-16's avionics and heads-up displays for decades.

Through the Collins Elbit Vision Systems (CEVS) joint venture with Collins Aerospace, an RTX business, Elbit America has delivered more than 3,000 Gen III Helmet-Mounted Display Systems for the F-35, reflecting more than a decade of production involvement with the Joint Strike Fighter program. In December, CEVS completed a Critical Design Review for its sixth-generation Zero-G Helmet-Mounted Display System+ (HMDS+), tailored to meet U.S. Navy requirements for the F/A-18E/F and EA-18G under the Improved Joint Helmet-Mounted Cueing System program. The system provides a fully immersive, high-definition view of the battlespace, with a focus on reducing pilot workload, while enhancing situational awareness and sensor integration.

GASTOPS

Headquarters: Ottawa, Ontario, Canada (U.S. office: Huntsville, Alabama)
Website: gastops.com

Gastops is a world leader in intelligent condition monitoring solutions for aircraft engines and other rotating equipment. As fighter aircraft age and engine health monitoring becomes increasingly critical to readiness, Gastops's solutions enable operators to improve mission availability and support informed flight-line maintenance decisions. Its portable and online debris analyzers detect metallic wear particles in engine oil, providing early warning of component degradation and the need for service before failures occur. This predictive maintenance approach allows operators to intervene proactively, helping them avoid costly unscheduled removals and reducing the risk of in-flight emergencies.

In August 2025, Gastops USA was awarded an \$18.6 million follow-on contract by the U.S. Air Force to supply its advanced ChipCHECK Portable Debris Analyzer, supporting front-line maintenance capabilities for jet engines and MRO for engines such as the General Electric F110 used in the F-15 and F-16.

Earlier last year, Gastops and RTX announced an agreement under Canada's Industrial and Technology Benefits policy. The result was a multi-million-dollar RTX investment in Gastops to support research and development aimed at advancing the next generation of oil debris monitoring technology for Pratt & Whitney military engines.

Gastops USA's ChipCHECK Portable Debris Analyzer—the subject of a follow-on U.S. Air Force contract targeting engines such as the General Electric F110 used in the F-15 and F-16—enables frontline maintainers to detect engine wear particles and take proactive measures to avoid emergencies and failures. (Image courtesy of Gastops.)



L3HARRIS TECHNOLOGIES

Headquarters: Melbourne, FL
Website: l3harris.com



Backed by partner nations, the AN/ALQ-254(V)1 Viper Shield electronic warfare suite is an all-digital system designed to maximize F-16 survivability in contested electromagnetic environments. Full-rate production is expected this year. (Image courtesy of L3Harris Technologies.)

L3Harris Technologies is entering a key production phase for its AN/ALQ-254(V)1 Viper Shield electronic warfare suite, a next-generation countermeasures system purpose-built for the F-16 Block 70/72. After years of development, Viper Shield entered low-rate initial production in late 2025, with full-rate production expected this year.

Multiple international customers have committed to the system, reflecting increasing demand for advanced survivability solutions. For instance, in August 2025, Poland emerged as an early customer to select Viper Shield for retrofit onto its existing Block 52-plus fighters. A podded version is also in development for customers seeking an external installation option.

On the international MRO front, in April 2024, L3Harris's Avionics Products Repair Station in Grand Rapids, Michigan, became the first U.S. repair station to receive European Military Airworthiness Requirement Part 145 (EMAR-145) certification, awarded by the French Directorate General of Armament eight months ahead of the customer-imposed deadline. The certification enables the facility to conduct repairs in accordance with European military airworthiness standards and support international customers operating under these requirements.

LOCKHEED MARTIN

Headquarters: Bethesda, Maryland
Website: lockheedmartin.com



Representatives from Poland and the U.S. gather following the signing ceremony marking Poland's commitment to modernize its forty-eight F-16 Block 52-plus fighters to the advanced Viper configuration. The upgrade, to be performed in partnership with Polish firm WZL-2, will position the nation among the most capable F-16 operators in Europe. (Photo courtesy of the Ministry of National Defence of the Republic of Poland.)

Not surprisingly, Lockheed Martin remains the central player in the Viper supply chain. Its Greenville, South Carolina, production facility is ramping up toward a delivery cadence of four aircraft per month, fulfilling a backlog of orders to customers such as Bahrain, Bulgaria, Jordan, Morocco, Slovakia, and Taiwan.

In December, Lockheed Martin reported progress on Block 70 production for Slovakia (fourteen aircraft) and Bulgaria's first batch (eight aircraft), positioning those nations among the first European operators to field newly built Block 70 aircraft. Also in 2025, Poland advanced a program valued at approximately \$3.8 billion to modernize its forty-eight-aircraft F-16 Block 52-plus fleet to the Viper Block 72 configuration, with work to be performed in partnership with the Polish firm WZL-2.

Beyond production, Lockheed Martin is investing in training infrastructure to support the global F-16 community. The company is supporting upgrades to flight simulators for the Republic of Korea Air Force to reflect the enhanced capabilities of the Viper configuration. The European F-16 Training Center (EFTC), inaugurated in November 2023 at Fetești Air Base in Romania, in partnership with that nation and the Netherlands, is increasing its training capacity for Allied pilots and is expected to support Ukrainian personnel.

MOOG

Headquarters: East Aurora, New York
Website: moog.com



Moog's newly expanded, 120,000-square-foot electromechanical actuation facility at the company's East Aurora, New York, headquarters consolidates development, production, and testing of actuation systems for aerospace and defense programs, including the F-16, under one roof. (Photo courtesy of Moog.)

Moog is a global designer, manufacturer, and integrator of precision motion control components and systems, with deep roots in military aviation. The company produces flight control actuation systems and components for numerous fighter platforms, including the F-16.

Controlling the precise movement of flight control surfaces, these systems are critical to aircraft maneuverability, where reliability and exacting tolerances are essential. In January 2024, Moog's hydraulic actuators performed successfully during the inaugural launch of United Launch Alliance's Vulcan Centaur rocket, demonstrating the company's role in advanced launch vehicle control systems.

Building on its success, Moog completed a major building expansion at its East Aurora, New York, headquarters last year, consolidating development, production, and testing of electromechanical, electrohydraulic, and electrohydraulic actuation systems in a single facility. The expansion enhances the firm's ability to support aviation defense and space programs. Moog also was recognized as the 2025 Business of the Year by the Buffalo Niagara Partnership.

NORTHROP GRUMMAN

Headquarters: Falls Church, VA
Website: northropgrumman.com

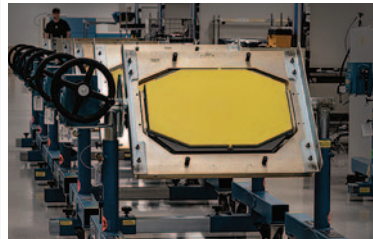

Northrop Grumman's AN/APG-83 Scalable Agile Beam Radar (SABR), the standard fire-control radar for the F-16 Block 70/72, draws on technology developed for the F-22 and F-35. Including recent U.S. Air Force contract modifications, the SABR program exceeds \$1.7 billion in total value. (Image courtesy of Northrop Grumman.)

Northrop Grumman's role in the F-16 community has never been more vital. The company is the sole producer of the AN/APG-83 Scalable Agile Beam Radar (SABR), the active electronically scanned array (AESA) fire-control radar selected by Lockheed Martin as standard for F-16 modernization and new Block 70/72 production aircraft.

Drawing on technology developed for the F-22 and F-35, SABR provides all-weather, high-resolution synthetic aperture radar mapping and long-range multi-target tracking, facilitating upgrades without major airframe changes. Since 2013, Northrop Grumman has delivered more than 900 SABR systems. A series of U.S. Air Force contract modifications in 2024 and 2025 brought the total program value to \$1.7 billion, with production contracted through 2031.

Complementing SABR is Northrop Grumman's Integrated Viper Electronic Warfare Suite (IVEWS), selected by the U.S. Air Force in 2019 and designed from the outset to operate seamlessly alongside the SABR radar across the shared radio frequency spectrum. Together, these systems provide F-16 pilots with enhanced radar capabilities and electronic self-protection, which the company describes as the ability to "dominate the electromagnetic spectrum." IVEWS has accumulated more than 250 flight hours and has been tested against airborne, maritime, and ground-based threats. Both SABR and IVEWS are available to F-16 operators worldwide.

PRATT & WHITNEY

Headquarters: East Hartford, Connecticut
Website: prattwhitney.com



Pratt & Whitney's F100-PW-229 turbofan undergoes testing. The engine, which has powered the F-16 since the model's introduction, continues to propel advanced Viper variants across a broad international customer base. Pratt & Whitney manages a substantial global workload of depot- and field-level engine overhaul and sustainment to ensure mission-readiness. (Photo courtesy of Pratt & Whitney.)

Pratt & Whitney, a division of RTX, has powered the F-16 since the aircraft's introduction with its F100 series turbofan engines, which remains one of two engine options for the Viper. The Pratt & Whitney F100-PW-229 powers advanced F-16 variants, including Block 50/52 and select Block 70/72 configurations, across a broad international customer base. The manufacturer manages a substantial global overhaul and sustainment F100 workload, providing depot- and field-level engine support to keep the Viper airborne. The company is also investing in advanced digital predictive maintenance technology to further improve engine availability and reduce unscheduled removals.

At the same time, Pratt & Whitney is competing to power the next generation of U.S. Air Force fighters. Its team is developing an adaptive cycle engine for the U.S. Air Force's Next Generation Adaptive Propulsion (NGAP) program, competing against GE Aerospace to potentially equip the service's next-generation air dominance platform. While that competition continues, Pratt & Whitney's legacy propulsion sustainment operations remain essential to the current fighter force.

RTX (RAYTHEON AND COLLINS)

Headquarters: Arlington, Virginia
Website: rtx.com



An AIM-120 Advanced Medium Range Air-to-Air Missile (AMRAAM) launches from an F-35A during a test firing. Produced by Raytheon Missiles & Defense, the AMRAAM — a standard armament for most F-16 operators and integrated across multiple Allied fighter platforms — is one of the most widely installed armaments of its type. (Photo courtesy of the F-35 Lightning II Joint Program Office.)

RTX's Raytheon Missiles & Defense division is a major player in the F-16's arsenal. The AIM-120 Advanced Medium Range Air-to-Air Missile (AMRAAM) and AIM-9X Sidewinder—both produced by Raytheon—are standard armaments for most F-16 operators. The AGM-65 Maverick, also a Raytheon product, remains in service with a number of legacy F-16 operators, though many modern Block 50/52 and 70/72 customers have transitioned to newer precision-guided munitions for air-to-ground missions. In fiscal year 2025, Raytheon received substantial AMRAAM production orders, driven by global restocking following transfers to Ukraine, along with high operational tempos across multiple combat theaters.

RTX's Collins Aerospace division provides critical avionics, environmental control systems, and power management solutions for a broad range of defense aircraft platforms. In April 2024, Collins Aerospace and Fokker Services Americas signed a FlightSense On-Site Support agreement to develop additional integrated drive generator repair capabilities at Fokker's MRO center in LaGrange, Georgia. This program effectively strengthens domestic supply chain resilience for aircraft power systems.

As the global F-16 fleet continues to expand and modernize, the need for integrated weapons and systems sustainment solutions across the RTX portfolio is expected to remain strong through this decade.

STANDARD AERO

Headquarters: Scottsdale, Arizona
Website: standardaero.com



A Chilean Air Force F-16C flies over Santiago, Chile. StandardAero's San Antonio, Texas, facility provides General Electric F110 engine MRO support for international F-16 operators, keeping Viper fleets like Chile's mission-ready. (U.S. Air Force photo by Technical Sergeant Rachel Maxwell.)

StandardAero is one of the world's largest independent providers of engine MRO services, with particular depth in defense aircraft propulsion. Its San Antonio, Texas, facility provides maintenance, repair, and overhaul services for the General Electric F110—one of the two engine families powering global F-16s, alongside the Pratt & Whitney F100. As both engine families accumulate flight hours in high-tempo operational environments, independent MRO providers like StandardAero play a growing role in keeping fleets airworthy without full dependence on original equipment manufacturer service pipelines.

The company is investing in enhanced capabilities and a broader global footprint, including advanced repair technologies and digital tools aimed at reducing engine turnaround time and improving aircraft availability. For F-16 operators managing aging powerplants and constrained depot capacity, StandardAero's combination of independent MRO expertise and technology investment offers a compelling sustainment option.



PAKISTAN

and its Air Force



Pakistan's Air Force badge. (Image courtesy of the Pakistan Air Force.)

By Tracy Martin

Throughout history, the territories that make up present-day Pakistan have been ruled by various empires and dynasties, most recently the British Raj, beginning in 1858. During World War II, when Japan threatened India, Britain came under increasing pressure to defend its territory and promised India eventual independence in return for wartime support. At the same time, the Pakistan Movement for independence, advocating a separate homeland for Muslims in British India, was gaining momentum. In 1947, the

partition of British India resulted in the creation of Pakistan as an independent state for Muslim-majority regions.

Pakistan adopted its first constitution in 1956 and was officially established as an Islamic republic. In 1971, the country experienced a major political crisis with the secession of East Pakistan, which became Bangladesh. In the following decades, Pakistan's governance alternated between civilian and military rule, and between democratic and authoritarian systems, reflecting shifts among secular and Islamist

political approaches. Today, Pakistan's governance is a Federal Parliamentary Islamic Republic.

Pakistan's textile and apparel industry is its largest market segment, with other manufacturing including advanced technologies on the rise. The nation also is rich in mineral reserves, as well as oil and natural gas. Its emerging economy is increasingly supporting a growing middle class.

A Chinese/Pakistan-produced CAC/PAC JF-17 Thunder flown by the Pakistan Air Force. (Photo courtesy of the Pakistan Air Force.)

PAKISTAN'S ARMED FORCES

Pakistan traces its military's origins to the British Indian Army, in which numerous Muslim soldiers served during the First and Second World Wars. Following the partition of British India and the creation of Pakistan in 1947, the country's military continued to reflect British structure and traditions. This influence remained dominant until 1956, when the United States sent a Military Assistance Advisory Group to help modernize Pakistan's defense forces. Today, Pakistan is a declared nuclear-armed state and regarded as a middle power.

The Pakistan Army was established in 1947 by Muslim officers who previously served in the British Indian Army. Today, it remains the country's largest military branch and operates as a professional volunteer force. The service is estimated to consist of approximately 560,000 active personnel, supported by 550,000 reservists.

Also in 1947, the Pakistan Navy was formed by Muslim officers from the Royal Indian Navy. Initially bearing the "Royal" designation, it was renamed in 1956, when Pakistan became an Islamic republic. The



Pakistan FAST FACTS

The following information was compiled in January 2026:

Capital	Islamabad
Land area	340,509 square miles (881,913 square kilometers)
Religion ..	96.3% Islam, 2.2% Hinduism, 1.4% Christian
Population	241,499 (2023)
Urban population ..	94,150,710 (2023)
Official Languages	Urdu, English
Literacy rate	Estimated at 60%
Currency	Pakistani rupee
GDP	\$410 billion (rank 40th)
Year of Independence	1947
Government	Federal Parliamentary Islamic Republic
President	Asif Ali Zardari
Prime Minister	Muhammad Shehbaz Sharif
Military Service Voluntary for men and women
Active military personnel	560,000
Reserve military personnel ..	550,000

Pakistan Navy's primary mission is to safeguard the country's ports, maritime borders, and roughly 650-mile (1,000-kilometer) coastline, while supporting national security and countering sea-based global terrorism, drug smuggling, and other illegal trafficking.

PAKISTAN'S AIR FORCE

With the creation of the Pakistan Air Force Academy in 1947, the Pakistan Air Force (PAF) was established as the central pillar of the nation's defense. The PAF is the world's seventh-largest air force and the largest among Muslim-majority nations. It operates approximately 600 combat fighters, along with more than 513 trainer, transport, communication, helicopter, and force-multiplier aircraft.

Historically, the PAF has relied on aircraft and technology from China, France, and the United States to expand its capabilities. While U.S.-made F-16s continue to form a key part of the fleet, Pakistan has increasingly turned to domestic production in partnership with China for other fighter models.

Jointly developed by the Chengdu Aircraft Corporation (CAC) of China and the Pakistan Aeronautical Complex (PAC), the CAC/PAC JF-17 Thunder has emerged as a major alternative platform to meet the air force's operational needs. This lightweight, multi-role combat aircraft continues to be developed at the Pakistan Aeronautical Complex, where further upgrades to the JF-17's avionics are underway. Currently, the PAF operates 161 JF-17s, alongside approximately sixty Chinese-built, MiG-21-derivative CAC F-7PG Skybolt fighters. As part of its modernization plans, the PAF is preparing to retire its aging Dassault Mirage IIIs and 5s, which were originally produced under French license.



A Pakistan flight crew at U.S. Nellis Air Force Base, participating in a Red Flag exercise. (Photo by Lawrence Crespo, courtesy of the U.S. Air Force.)



A Pakistan Air Force F-16 C/D Block 52 fighter. (Photos courtesy of the U.S. Air Force.)



A Pakistan Air Force CAC J-10C fighter jet lifts off. (Photo courtesy of the Pakistan Air Force.)



Pakistan's AIR FLEET

AircraftQuantity

Combat Aircraft

CAC F-7PG Skybolt	.60
CAC J-10C Vigorous Dragon	.20
CAC/PAC JF-17 Thunder	.161
Dassault Mirage III	.135
Dassault Mirage 5	.139

General Dynamics/Lockheed Martin F-16

Fighting Falcon	.85
-----------------	-----

Transports

Airbus A319	.1
Beechcraft Super King Air	.2
CASA/IPTN CN-235	.4
Cessna Citation Excel	.2
Cessna 208 Caravan	.2
Dassault Falcon 20	.1
Embraer Phenom 100	.6
Gulfstream IV	.2
Harbin Y-12	.3
Lockheed Martin C-130 Hercules	.25
Lockheed Martin L-100 Hercules	.2
Piper M600	.2
Saab 2000	.6

Helicopters

AgustaWestland AW139	.14
----------------------	-----

Trainer Aircraft

Cessna T-37 Tweet	.73
Hongdu K-8	.60
Mushshak MFI-17 PAC	.151
Socata TB 30	.15

Electronic Warfare Aircraft

Bombardier Global 6000	.1
Dassault Falcon DA-20	.2
Shaanxi ZDK-03	.4

Early Warning & Control

Saab 2000 Erieye AEW&C	.10
------------------------	-----

Unmanned UAVs

Baykar Bayraktar Akinci	.7
Baykar Bayraktar TB2	.Unknown
CAIG Wing Loong II	.3
CASC CH-4 Rainbow	.24
GIDS Shahpar	.6
GIDS Shahpar-II	.Unknown
NESCOM Burraq	.13
SATUMA Jasoos II	.46
Selex ES Falco	.26
TAI Anka	.Unknown

In 1981, the United States began selling General Dynamics F-16 Fighting Falcon fighters to Pakistan. At the time, this General Dynamics model represented cutting-edge aviation technology, featuring fly-by-wire controls, exceptional maneuverability, and the ability to reach speeds of up to Mach 2, while carrying heavy weapons loads. Between 1982 and 1986, Pakistan received twenty-eight F-16A single-seat fighters and twelve two-seat F-16B variants through Saudi Arabia under the Peace Gate I and II programs.

By 1990, Pakistan had placed orders for seventy-one upgraded F-16A/B Block 15 aircraft. However, concerns over the nation's nuclear program prompted the

United States to impose sanctions that year. As a result, twenty-eight newly built F-16s (already paid for by Pakistan) were withheld and stored at a facility in Arizona.

In the late 1990s, the United States offered to release the stored aircraft, if Pakistan agreed to refrain from conducting nuclear weapons tests. Pakistan rejected the proposal and carried out underground nuclear detonations in 1998, following similar tests by India. U.S. intelligence at the time again raised concerns that Pakistan could adapt its existing F-16 fleet to deliver nuclear weapons.

After the September 11, 2001 terrorist attacks, however, the United States enlisted Pakistan's cooperation in operations against

the Taliban. Subsequently, the George W. Bush administration approved the "Peace Drive" agreement, leading to the delivery of the Peace Gate F-16A and F-16B aircraft, along with newer Lockheed Martin F-16C and F-16D Block 52 fighters.

In December 2025, the United States approved a new \$686 million upgrade package for Pakistan's F-16 fleet. This action marked a significant step in renewed defense cooperation between the two nations amid ongoing regional tensions.

The modernization program focuses on improving interoperability and long-term sustainment of Pakistan's existing F-16 fleet, including Block 50/52 and Mid-Life Upgrade (MLU) variants. It involves integration of advanced communication, navigation, and

testing equipment, aimed at keeping the aircraft operational through 2040.

The package includes ninety-two Link-16 systems, which provide secure, jam-resistant, high-capacity digital links for near real-time exchange of tactical data and voice communications among air, land, and sea resources. Additionally, Mk-82 inert 500-pound bomb bodies are included for integration and testing purposes.

Overall, the upgrades are expected to strengthen Pakistan's air defense capabilities against regional rivals. These upgrades also will enable the Pakistan Air Force to operate more effectively alongside U.S. and NATO forces, reinforcing both military and diplomatic ties.

Sources

"Pakistan Deploys F-16 Fighting Falcons Near India's Border as Tensions Simmer," *Military Watch Magazine*, March 2019, www.militarywatchmagazine.com.
Mike Rajkumar, "Pakistani F-16s receive US upgrade approval," *Asian Military Review*, December 2025, www.asianmilitaryreview.com.
Sebastien Roblin, "Inside the Combat History of the Pakistani Air Force's F-16 Fleet," *The National Interest*, September 2021, www.nationalinterest.org.
"What is the Chinese-made F-7 jet that crashed into Bangladesh school?" *Reuters*, July 2025, www.reuters.com.
Wikipedia, www.en.wikipedia.org.
The World Bank, www.worldbank.org.



F-4 PHANTOM



F-5 FREEDOM FIGHTER



F-15 EAGLE

F-15E Strike Eagles from the 494th Fighter Squadron at Royal Air Force Lakenheath, England, arrive at a forward-deployed location in Southwest Asia. (U.S. Air Force photo by Master Sgt. Terry L. Blevins.)

Legacy Worldwide FIGHTERS 2026

By Tracy Martin

TurAF's 50th year special livery for mighty Phantom.
(Work of Batuhan Akcaya)

Amid perpetual efforts to ensure national security, dependable fighter aircraft continue to play a crucial role. Although fifth-generation platforms such as the F-35 Lightning II deliver advanced technological capabilities, high costs and complex maintenance requirements make newer aircraft inaccessible for many operators.

Consequently, countries around the world still rely on fourth-generation fighters to maintain effective air power, deter potential threats, and protect their airspace. Proven aircraft such as the McDonnell Douglas F-4 Phantom and F-15 Eagle, the Northrop F-5 Freedom Fighter, and the General Dynamics/Lockheed Martin F-16 Fighting Falcon remain indispensable for projecting air power. These cost-effective, battle-tested fighters offer reliable air defense solutions for countries seeking a balance between operational performance and affordability.

F-4 PHANTOM

Introduced by McDonnell Douglas in 1960, the F-4 Phantom has secured its place in military aviation history and production records show the aircraft remained in manufacture through the 1970s. In addition to U.S. manufacturing, more than 120 F-4s were built under license by Mitsubishi in Japan, bringing the total number of the two-seat fighter-bomber close to 5,200. The last F-4 was completed in 1981. After its merger with McDonnell Douglas in 1997, Boeing continued support of the model.

Originally developed as a carrier-based interceptor, the F-4 Phantom became a key asset of the U.S. defense forces, most notably during the Vietnam War, where it saw extensive service with the U.S. Marine Corps and U.S. Navy. Although early versions lacked an internal cannon, the Phantom compensated with exceptional weapons capacity. Equipped with nine external hardpoints, it could carry up to

18,650 pounds of ordnance, including air-to-air and air-to-ground missiles, as well as nuclear weapons.

Also flown by the U.S. Air Force, the F-4s in U.S. military service were phased out through the late 1990s. Old F-4s converted into QF-4 target drones, used for live-training exercises, operated until 2016. Currently, only three countries operate the F-4: Greece, Turkey, and Iran.

The Hellenic Air Force of Greece has invested heavily in keeping its F-4E fleet relevant through comprehensive modernization programs. Upgrades have included the AN/APG-65GR radar, CPU143/A central air data computer, MMRC modular mission computers, and modernized cockpits with multifunction displays. A Lightning II airborne laser designator enables the F-4EAUP to engage ground targets with precision-guided munitions from high altitudes, avoiding short- and medium-range defenses.

Thanks to an upgrade program developed with Israel, Turkey's F-4E 2020 Terminator is a versatile variant with enhanced combat capabilities. It features new heads-up displays and avionics, Elta EL/M-2032 multimode airborne fire-control radar, added electronic countermeasures, structural reinforcements, and modern weapons integration. Optimized for long-range strike and reconnaissance, these Turkish Phantoms carry heavy payloads, such as AGM-142 standoff missiles, AGM-65 air-to-ground missiles, and laser-guided bombs.

Iran is often cited as the most unexpected remaining operator of the F-4 Phantom. Decades of international sanctions, limited access to spare parts, and persistent regional conflict make sustained operations seem improbable. Yet the Islamic Republic of Iran Air Force (IRIAF) continues to utilize a total of sixty-four F-4D and F-4E aircraft in both reconnaissance and strike roles.

F-5 FREEDOM FIGHTER/TIGER

First introduced in the 1960s, the Northrop F-5 family of lightweight, supersonic fighter jets marked a significant advance in military aviation. Early variants, including the F-5A/B Freedom Fighter, first operated in the late 1950s, paving the way for the more capable F-5E/F Tiger II, which entered service in the early 1970s.

Valued for its affordability, ease of maintenance, and agile performance, the model offered a practical alternative to larger and more complex fighters like the F-4 Phantom II. Originally adopted by the U.S. Navy, the F-5 soon found widespread acceptance among air forces worldwide,

notably those of the Republic of China and the Republic of Korea.

Throughout the Cold War, the United States supplied F-5s to allied nations through military assistance programs designed to bolster collective air defense capabilities, a role that earned the aircraft its "Freedom Fighter" nickname. Countries operating the jet included Canada, Greece, Iran, Norway, South Korea, Spain, Taiwan, Thailand, and Turkey. While a number of the forces that originally flew the F-5 have since transitioned to more advanced aircraft, thanks to structural life-extension efforts and upgraded avionics and subsystems, it remains in service with a dozen nations.

In 2026, the F-5 Tiger II continues to prove itself as a cost-effective and versatile platform. It remains cheaper to procure and operate than newer fighters, making it ideal for less demanding roles, such as mimicking adversaries for training purposes. Glass cockpits, integration of modern systems (like the LN-260 INS), and other key upgrades enhance the model's functionality. And Northrop Grumman's continued support enables these older airframes to remain operational through targeted maintenance and sustainment.

Today, the F-5 serves in training and adversary roles for the U.S. Navy and U.S. Marine Corps. Upgraded ex-Swiss F-5Ns/Fs are being integrated to enhance capabilities for "Red Air" training, replacing older jets and supporting new squadrons. The Swiss Air Force's aerobatic team Patrouille Suisse also will continue flying F-5s in demonstrations at least into 2027. At the same time, Brazil's and other nations' upgraded F-5s are expected to stay in

service as part of their active air forces until replaced by newer fighters.

F-15 EAGLE

The F-15 Eagle is a twin-engine, all-weather fighter developed in the United States by McDonnell Douglas, later acquired by Boeing through a 1997 merger. Since entering operational service in 1976, the F-15 has served as a foundational element of the U.S. Air Force fleet, and it has been exported to key allies, including Israel, Japan, and Saudi Arabia.

The fighter's capabilities evolved significantly in 1989 with the debut of the F-15E Strike Eagle. Designed for long-range, precision strike missions, this version still offers formidable air-to-air combat capabilities.

In July 2020, the U.S. Air Force awarded Boeing an exclusive, open-ended contract to modernize its F-15 fleet through the F-15EX program. Aiming to eventually replace legacy F-15C/Ds and enhance F-15Es, the F-15EX Eagle II features state-of-the-art avionics, extensive weapons capacity, and advanced electronic warfare systems, enabling effective operations in contested environments alongside fifth-generation stealth fighters.

As of this year, the U.S. Air Force F-15 fleet consists of a mix of both F-15C/Ds and F-15EXs. While most of the F-15C/Ds are moving toward retirement, select airframes are being retained for homeland defense, and some are even predicted to remain in service through 2031. Production of the F-15EX will continue to accelerate as older variants are phased out.

Meanwhile, international partners continue to operate older F-15s, as well as

F-16 FIGHTING FALCON



F-16 Fighting Falcons with the U.S. Air Force Air Demonstration Squadron, the Thunderbirds, perform during the Speed of Sound Airshow at Rosecrans Air National Guard Base in St. Joseph, Mo., Sept. 15, 2024. Hosted by the 139th Airlift Wing and city of St. Joseph, the event was a chance to thank the community and approximately 50,000 attendees for their support. (U.S. Air National Guard photo by Master Sgt. Patrick Evenson)

acquire advanced versions of the Eagle, including Israel's F-15IA, Qatar's F-15QA, Saudi Arabia's F-15SA, and Indonesia's newly ordered models. The F-15 platform undoubtedly will continue to serve as a mainstay of defense aviation operations for decades to come.

F-16 FIGHTING FALCON

The Lockheed Martin F-16 Fighting Falcon, originally developed by General Dynamics, remains one of the most widely operated legacy fighters in the world. Designed initially as a lightweight, daytime air defense fighter, the F-16 has evolved into a highly capable multirole platform, able to conduct air-to-air and air-to-ground missions in all-weather conditions.

The newest variant, the F-16V Viper features notable technological upgrades. These include a large-format, high-resolution cockpit display, an active electronically scanned array (AESA) radar, state-of-the-art avionics, enhanced data bus and communications systems, precision GPS navigation, an automatic ground collision avoidance system, advanced targeting pods, and compatibility with various precision-guided weapons.

Starting in 2023, the United States approved the transfer of U.S.-made F-16s to Ukraine. In addition, the Netherlands and Denmark began delivering F-16s last summer, with aircraft shipments ongoing. In May 2024, Belgium also announced plans to donate thirty surplus F-16s, with a plan to complete the transfers by 2028.

To make their fighters more effective, Ukrainian Air Force officers developed new tactics for operating the F-16s in combat against Russian forces, emphasizing low-altitude, terrain-following flight profiles and using decoy maneuvers. Flying close to the ground reduces the effectiveness of Russian radar and missile systems, as terrain interference makes it harder for sensors to track and lock onto aircraft.

The Bulgarian Air Force is actively integrating its new F-16 Block 70s into its fighter fleet, flying them alongside legacy MiG-29s during training operations. The F-16 Block 70s feature conformal fuel tanks and advances such as an APG-83 AESA radar (comparable to systems used on the F-35) and an Automatic Ground Collision Avoidance System (Auto GCAS). When fully delivered, Bulgaria's fleet of sixteen F-16s is expected to replace its Soviet-era aircraft, enhancing combat readiness and regional security. This investment supports Bulgaria's commitment to strengthening its defenses against evolving security threats in the region. It also reinforces the nation's role within the North Atlantic Treaty Organization (NATO) by providing interoperable air defense capabilities aligned with allies' standards.

F-16S IN ASIA

As of early 2026, threats from China are evolving in escalated military ambitions, particularly concerning

Taiwan, economic coercion through trade restrictions (rare earths elements, various technologies, etc.), cyber warfare, and geopolitical assertiveness in Asia. This reality has driven Asia's F-16 fighter landscape to be shaped by acquisition and modernization programs in both Taiwan and the Philippines. While the F-16 remains central to regional air power, these countries, and others like Thailand, are also diversifying their fleets with alternate platforms, such as Korea Aerospace Industries (KAI) FA-50 and Saab Gripen E/F fighters.

Taiwan's largest fighter acquisition involves sixty-six new F-16V Block 70 aircraft, though the program continues to face production delays. With full delivery originally expected this year, supply chain disruptions and technical challenges have pushed completion into the 2027–2028 timeframe. In parallel, Taiwan is upgrading its existing F-16 fleet to the F-16V standard, enhancing combat capability through improved radars, avionics, and mission systems.

Amid rising tensions in the South China Sea, the Philippine Air Force (PAF) plans to acquire twenty F-16 Block 70/72 fighters, with deliveries potentially beginning this year. However, the proposed \$5.6 billion deal remains uncertain due to budget constraints. At the same time, the PAF also is moving forward with upgrades to its KAI FA-50PH multirole fighters with stated intentions to double the size of this fleet. The improvements include installation of AESA radars and enhanced avionics for both existing and new aircraft.

The Royal Thai Air Force has plans to gradually replace part of its F-16 fleet with the Saab Gripen E/F. In August, Thailand signed a \$500 million contract for three Gripen E fighters and one Gripen F, with deliveries scheduled for completion by 2030. The agreement includes technology transfer, training, logistical support, and offset programs, building upon Thailand's existing Gripen C/D fleet. This acquisition forms part of a broader modernization strategy aimed at replacing aging aircraft.



SOURCES

Antonio Di Trapani, "Why The F-4 Phantom Won't Be Retired Anytime Soon," January 2026, *Simple flying*, www.simpleflying.com.
 "The first of 16 new F-16 fighter jets from the US land in Bulgaria," April 2025, *Euromaidan Press*, www.apnews.com.
 Jon Jackson, "Ukraine to Receive Expedited Delivery of F-16s," April 2024, *Newsweek*, www.newsweek.com.
 Brad Lendon, "U.S. approves sale of 20 U.S. F-16 fighter jets to Philippines as Washington tightens key Asian alliance," April 2025, *CNN News*, www.cnn.com.
 Stephen Pope, "Lockheed Martin Completes Production of Initial F-16 Block 70 Fleets for Bulgaria and Slovakia," December 2025 press release, Lockheed Martin, news.lockheedmartin.com.
 Lucy Powell, "Lockheed Martin 'bullish' on future of its F-16 programme," March 2025, *Shepard Media*, www.shephardmedia.com.
 "Royal Thai Air Force confirms selection of Saab's Gripen E/F," 2025 Press Release, *Saab*, www.saab.com.
 Maria Tril, "Ukraine to receive additional F-16 fighter jets — US General," April 2025, *Euromaidan Press*, www.euromaidanpress.com.
 "Ukraine Develops Entirely New Tactics for its F-16 Fighters: Officers Slam Western Air Doctrine as Unsuitable," January 2026, *Military Watch Magazine*, www.militarywatchmagazine.com.
 Greg Waldron, "Korea Aerospace Industries wins deal to upgrade 11 FA-50PH light attack aircraft for Philippine air force," December 2025, *FlightGlobal*, www.flightglobal.com.

Following is a list of key legacy fighter aircraft in worldwide fleets at the time of this writing.

MCDONNELL DOUGLAS F-4 PHANTOM

Greece	Hellenic Air Force	17
Iran	Islamic Republic of Iran Air Force	64
Turkey	Turkish Air Force	48

NORTHROP F-5 FREEDOM FIGHTER/TIGER

Brazil	Brazilian Air Force	42
Chile	Chilean Air Force	11
Honduras	Honduran Air Force	9
Iran	Islamic Republic of Iran Air Force	35
Kenya	Kenya Air Force	23
Mexico	Mexican Air Force	8
Morocco	Royal Moroccan Air Force	22
South Korea	Republic of Korea Air Force	61
Switzerland	Swiss Air Force	15
Thailand	Royal Thai Air Force	13
Tunisia	Tunisian Air Force	10
United States	U.S. Navy and U.S. Marine Corps	40
Yemen	Yemen Arab Republic Air Force	11

MCDONNELL DOUGLAS/BOEING F-15 EAGLES

Israel	Israel Air and Space Force	66 (25 on order)
Japan	Japan Air Self-Defense Force	199
Qatar	Qatar Emiri Air Force	37
Saudi Arabia	Royal Saudi Air Force	211
Singapore	Republic of Singapore Air Force	40
South Korea	Republic of Korea Air Force	59
United States	United States Air Force	334

GENERAL DYNAMICS—LOCKHEED MARTIN F-16 FIGHTING FALCON

Bahrain	Royal Bahraini Air Force	22
Belgium	Belgian Air Component	44
Bulgaria	Bulgarian Air Force	8 (8 on order)
Chile	Chilean Air Force	46
Denmark	Royal Danish Air Force	26
Egypt	Egyptian Air Force	218
Greece	Hellenic Air Force	152
Indonesia	Indonesian Air Force	33
Israel	Israel Air and Space Force	174
Jordan	Royal Jordanian Air Force	74 (16 on order)
Morocco	Royal Moroccan Air Force	23
Oman	Royal Air Force of Oman	12
Pakistan	Pakistan Air Force	85
Poland	Polish Air Force	47
Portugal	Portuguese Air Force	28
Romania	Romanian Air Force	33
Singapore	Republic of Singapore Air Force	59
Slovakia	Slovak Air Force	14
South Korea	Republic of Korea Air Force	167
Taiwan	Republic of China Air Force	140
Thailand	Royal Thai Air Force	46
Turkey	Turkish Air Force	236 (40 on order)
United Arab Emirates	United Arab Emirates Air Force	55
United States	United States Air Force	657
Venezuela	Venezuelan Military Aviation	3

COMPANY PROFILES

The companies listed on the following pages are suppliers of parts, components, systems and repairs for the fighter aircraft aftermarket. Firms indicated in **BOLD** type with their logo and description have been vetted by the publishers as bona-fide sources of supply and are the best in the business, providing quality equipment and services at a price that reflects true value for the purchaser. We suggest you contact these businesses for all your supply and repair needs, since they are dedicated to your satisfaction as customers. If they do not have the exact part or repair you require, they can act on your behalf to locate a solution for you. For more information please contact Richard Greenwald at r.greenwald@abdonline.com.

* This magazine is an independent publication of Wright Media, Inc. As such it is not affiliated with the F-16 TCG WWR show and is therefore able to maintain an independent perspective. All information contained within has been assembled from sources believed to be reliable, but we cannot accept any responsibility for inaccuracies. The inclusion of information for or about any company or contractor does not imply endorsement by the U.S. Air Force of that organization's products or services. Regarding any inaccuracies, or if you would like to be represented in the next Program Guide for this or other events in the industry, please contact r.greenwald@abdonline.com or call 914-244-8899. Thank you.

AAR AIRCRAFT COMPONENT SERVICES - NEW YORK
 70 State Street
 Westbury, NY 11590 U.S.A.
 Contact: Business Development
 F-16@aarcorp.com
 www.aarcorp.com



AAR is a world leader in Aircraft Component Repair, Supply Chain & Depot Support. Our F-16 experience includes Accessory Drive Gearbox, Jet Fuel Starter, Speed Brake & Landing Gear components, Depot Level Training & Specialized Test Stands. AAR is an FAA/EASA Repair Center with ISO 9001:2015, AS9100D & AS9110C. See our advertisement on the back cover.

AAR AIRCRAFT COMPONENT SERVICES - AMSTERDAM
 Kruisweg 705, 2132 ND Hoofddorp
 The Netherlands
 Contact: Business Development
 F-16@aarcorp.com
 www.aarcorp.com



AAR is a world leader in Aircraft Component Repair, Supply Chain & Depot Support. Our F-16 experience includes Accessory Drive Gearbox, Jet Fuel Starter, Speed Brake & Landing Gear components, Depot Level Training & Specialized Test Stands. AAR is an FAA/EASA Repair Center with ISO 9001:2015, AS9100D & AS9110C. See our advertisement on the back cover.

ABLE AEROSPACE
 7706 East Velocity Way
 Mesa, AZ 85212 U.S.A.

ACCUDRAFT PAINT BOOTHS
 961 Rte. 10E
 Randolph, NJ 07869 U.S.A.

AEREOS DEFENSE
 1100 South Pipeline Road West
 Euless, TX 76040 U.S.A.

AERO ENGINEERING & MANUFACTURING CO.
 28217 Ave. Crocker
 Valencia, CA 91355 U.S.A.

AERO ENGINEERING SUPPORT GROUP, INC.
 3601 Commerce Blvd., Suite F
 Kissimmee, FL 34741 U.S.A.
 Contact: Boris Masera
 info@AESGworld.com
 www.AESGworld.com



AESG specializes in providing test and repair solutions on a wide range of support for military and commercial avionics including Accessories, INUs, CADCs, CCAs, PSUs, Gyros, HUDs, Counter Measurement Equipment, Radars, Instruments, Platform Assemblies, and much more. AESG delivers high-quality, cost effective test solutions throughout the world.

AERO TURBINE, INC.
 6800 S. Lindbergh Street
 Stockton, CA 95206 U.S.A.

AEROCORE TECHNOLOGIES
 228 W. 700S
 Lebanon, IN 46052 U.S.A.

AERO-GLEN INTERNATIONAL, LLC
 13751 Independence Pkwy.
 Fort Worth, TX 76177 U.S.A.

AERO-HOSE, CORPORATION
 1845 Town Center Blvd., Suite #140
 Fleming Island, FL 32003 U.S.A.

AERONIX, INC.
 1775 W. Hibiscus Blvd.
 Melbourne, FL 32901 U.S.A.

AEROSPACE MAINTENANCE SOLUTIONS, LLC
 29401 Ambina Dr.
 Solon, OH 44139 U.S.A.

AIR QUALITY AVIATION, ESTABLISHED IN 2001, IS A RECOGNIZED LEADER IN COMPONENT REPAIRS AND OVERHAULS SERVICING



AIR QUALITY AVIATION INC.
COMMERCIAL, HELICOPTER AND MILITARY APPLICATIONS
 A LOCKHEED MARTIN APPROVED REPAIR CENTER

WE ARE EXPERTS IN THE REPAIR AND OVERHAUL OF
 Landing Gears • Fans • Gearbox • Pneumatics Valves • Landing Lights • Beacon Lights • Fuel Valves
 Fuel Boost Pumps • Hydraulic Pumps • Linear Actuators • Rotary Actuators • Ballscrew Assemblies

CAGE CODE 1U2L6
 F.A.A. Repair Station Certification: QL9R709Y
 EASA 145.5344 • ISO 9001:2015 / AS9110
 SBA Certified Business • ITAR Registered



AEROWING
 5217 Linbar Drive
 Nashville, TN 37211 U.S.A.

AEROWORX, INC.
 2565 W. 237th Street
 Torrance, CA 90505 U.S.A.

AIR QUALITY AVIATION, INC.
 5773 Miami Lakes Drive
 Miami Lakes, FL 33014 U.S.A.
 Contact: Luis Cordero
 Lcordero@airqualityaviation.com
 www.airqualityaviation.com



Air Quality Aviation is an F.A.A. and Lockheed Approved Repair Center specializing in the repair and overhaul of components, accessories, and Landing gear for Military aircraft. Having achieved quality approvals for FAA, EASA, UK CAA approval, ISO9001:2015, AS9110 Rev.C, we strive to maintain high quality through continuous improvement. See our advertisement above.

AIR SHUNT INSTRUMENTS, INC.
 9101 Winnetka Ave.
 Chatsworth, CA 91311 U.S.A.
 rfq@airshunt.com
 www.airshunt.com



Avionics & Instrument Repair Altimeters | Gyros | Fuel Quantity Indicators | Air Speed Indicators | Receiver Transmitters | Transponders Rockwell Collins | Marconi | GE | Kollsman | Aerosonic | Litton | Astronautics | Grimes | Lear Siegler | Honeywell | Loral | R.C. Allen | Teledyne
 See our advertisement on page 32.

AIRCRAFT COMPONENT REPAIR
 25058 Anza Drive
 Valencia, CA 91355 U.S.A.

AIRCRAFT HINGE, INC.
 28338 Constellation Road
 Valencia, CA 91355 U.S.A.

AIRVRIX LTD
 HALOTUS 10
 Oranit, IS 4481300 Israel

AMERICAN DATA SOLUTIONS, INC.
 2400 Herodian Way
 Smyrna, GA 30080 U.S.A.

AMETEK MRO
 4085 Southwest Blvd.
 Tulsa, OK 74107 U.S.A.

AMS AIRCRAFT RECOVERY
 426 East Duarte Road
 Monrovia, CA 91016 U.S.A.

ARTEMIS ELECTRONICS LLC
 13400 W. Hwy 42, Suite 180
 Prospect, KY 40059 U.S.A.

ASTRONAUTICS CORP OF AMERICA
 135 W. Forest Hill Ave.
 Oak Creek, WI 53154 U.S.A.

ASTRONICS AEROSAT
 220 Hackett Hill Road
 Manchester, NH 03102 U.S.A.

WE'RE UP THERE WITH YOU
 WE HOUSE OVER 10 MILLION SPARE PARTS FOR ALL AIRCRAFT

MILITARY & COMMERCIAL
 SPECIALIZING IN MILITARY AND COMMERCIAL AVIONICS INSTRUMENT REPAIR
 WORLDWIDE SUPPORT OF:
 • ALTIMETERS
 • GYROSCOPIES
 • FUEL QUANTITY INDICATORS
 • AIR SPEED INDICATORS
 • RECEIVER TRANSMITTERS
 • TRANSPONDERS

SUPPORTING PRODUCTS MANUFACTURED BY:
 ROCKWELL COLLINS • ALLIED SIGNAL • MARCONI • GENERAL ELECTRIC • KOLLSMAN • AEROSONIC • LITTON • GULL ELECTRONICS • ASTRONAUTICS • GRIMES • LEAR SIEGLER • HONEYWELL • LORAL • R.C. ALLEN • TELEDYNE

WWW.AIRSHUNT.COM
 AIR SHUNT INSTRUMENTS, INC. | 9101 WINNETKA AVE. | CHATSWORTH, CA 91311 | T: (818) 700.1616 | F: (818) 700.2882
 RFQ@AIRSHUNT.COM

BAE SYSTEMS
 6100 Western Place
 Fort Worth, TX 76107 U.S.A.

BARFIELD, INC.
 4101 N.W. 29th Street
 Miami, FL 33142 U.S.A.

BAUER, INC.
 175 Century Drive
 Bristol, CT 06010 U.S.A.

BEMSCO DEFENSE PRODUCTS
 1193 400 West
 Salt Lake City, UT 84101 U.S.A.

BLUE AEROSPACE
 6211 N. Nob Hill Road
 Tamarac, FL 33321 U.S.A.

CAE DEFENSE & SECURITY
 4908 Tampa West Blvd.
 Tampa, FL 33634 U.S.A.

CAE USA
 4840 Westfields Blvd., Suite 300
 Chantilly, VA 20151 U.S.A.

CALCULEX, INC.
 132 W. Las Cruces Ave.
 Las Cruces, NM 88001 U.S.A.

CAMAR AIRCRAFT PARTS CO.
 743 Flynn Road
 Camarillo, CA 93012 U.S.A.

CHENEGA WORLDWIDE SUPPORT
 10505 Furnace Road, Suite 205
 Lorton, VA 22079 U.S.A.

CHROMALLOY
 3999 RCA Blvd.
 Palm Beach Gardens, FL 33410 U.S.A.

CLAYTON ASSOCIATES, INC.
 1650 Oak S.
 Lakewood, NJ 08701 U.S.A.

COC AEROSPACE, INC.
 50 Durley Ave.
 Camarillo, CA 93010 U.S.A.

COLLINS AEROSPACE
 2730 W. Tyvola Road
 Charlotte, NC 28217 U.S.A.

COMMUNICATIONS & POWER INDUSTRIES
 811 Hansen Way
 Palo Alto, CA 94304 U.S.A.

CONTINENTAL AIRCRAFT SUPPORT, INC.
 13960 N.W. 60th Ave.
 Miami Lakes, FL 33014 U.S.A.

CRANE AEROSPACE & ELECTRONICS
 16700 13th Ave. W.
 Lynnwood, WA 98037 U.S.A.

CUMMINS AEROSPACE
 2320 E. Orangethorpe Ave.
 Anaheim, CA 92806 U.S.A.

A TEC, INC.
 12600 Executive Drive
 Stafford, TX 77477 U.S.A.

A TEQ & COBRA SYSTEMS, INC.
 3216 S. Nordic Rd.
 Arlington Heights, IL 60005 U.S.A.

ATT METROLOGY SERVICES
 30210 S.E. 79th St., Suite 100
 Issaquah, WA 98027 U.S.A.

AVALEX TECHNOLOGIES
 2665 Gulf Breeze Parkway
 Gulf Breeze, FL 32563 U.S.A.

AVIATION AFTERMARKET DEFENSE 914-244-8899
 P.O. Box 110382
 Naples, FL 34108 U.S.A.
 Contact: Richard Greenwald
 r.greenwald@abdonline.com
 www.abdonline.com

Serving the defense aviation aftermarket, AAD is recognized worldwide as the industry periodical for military aircraft. Published semi-annually, AAD magazine combines engaging articles with directory-type listing information for transports, fighters, and rotorcraft. Also publishers of "Wright Prospector," "Contact!" magazine, and "The Program Guide."

AVIATION GROUND EQUIPMENT CORP.
 324 South Service Road
 Melville, NY 11747 U.S.A.

AVIATION PROCUREMENT SYSTEMS (APS)
 211 Perry Parkway, Suite 5
 Gaithersburg, MD 20877 U.S.A.

CELEBRATING OVER 35 YEARS IN THE AEROSPACE INDUSTRY SINCE 1989

GLOBAL DEFENSE SUPPORT
 Leader in the aerospace industry since 1989, as a family-owned business we deliver mission-ready aircraft parts, repair management, and logistics for military and commercial fleets worldwide.

With strong OEM partnerships and our own inventory acquisitions, we keep hard-to-find legacy and current aircraft parts in stock and ready to ship. Our team ensures fast fulfillment, export compliance, and complete repair oversight through trusted OEM, FAA, and EASA repair stations.

From inventory to integrity, we are committed to keeping your mission flying because YOU CANT FLY WITHOUT SUPPLY™.

INVENTORY IN STOCK

764828-4 Turbine Cooling	5004451H F-16 Accessory Drive Gearbox	1686568-2 Valve Bleed Air Shutoff
764967-7 Heat Exchanger	16P1873-849 Grip	1686568-2 Door

DTE
 Defense Technology Equipment Inc.®

21300 Ridgetop Circle, Sterling, VA 20166 USA
 www.Defense-Tech.com
 Phone: +1(703) 766-1700
 Fax: +1(703) 766-1701
 Sales@Defense-Tech.com

CURTISS-WRIGHT DEFENSE SOLUTIONS
 20130 Lakeview Center Plaza, Ste. 200
 Ashburn, VA 20147 U.S.A.

DANIELS MANUFACTURING
 526 Thorpe Road
 Orlando, FL 32824 U.S.A.

DAVID CLARK COMPANY, INC. 508-751-5800
 360 Franklin Street
 Worcester, MA 01615 U.S.A.
 Contact: Ken Times
 ktimes@davidclark.com
 www.davidclark.com

WWW.DAVIDCLARK.COM

David Clark Company Inc. (DCCI) is the world leader in headsets for military, marine and general aviation and specializes in communication solutions for any high-noise environment. Our Worcester, MA, facility has been manufacturing headsets and communication systems for over half a century.

DEFENSE TECHNOLOGY EQUIPMENT, INC. 703-766-1700
 21300 Ridgetop Circle
 Sterling, VA 20166 U.S.A.
 Contact: Maria Badillo
 mbadillo@defense-tech.com
 www.defense-tech.com

DTE is the leader in aftermarket sales and distribution of components of rotables & consumables in the aerospace industry. DTE specializes in logistic military procurement, OEM distribution, Supply Chain, Repair Management services, and hard-to-find items. DTE is proudly celebrating 37 years of success in the industry. Sales@defense-tech.com See our advertisement above.

DERCO, A LOCKHEED MARTIN COMPANY
 8000 West Tower Ave.
 Milwaukee, WI 53223 U.S.A.

DIT-MCO INTERNATIONAL CORP.
 5612 Brighton Terrace
 Kansas City, MO 64130 U.S.A.

DRYTECH, INC.
 54 Wrightstown-Cookstown Road
 Cookstown, NJ 08511-0128 U.S.A.

DUOTECH SERVICES
 245 Industrial Park Road
 Franklin, NC 28734 U.S.A.

EAST/WEST INDUSTRIES, INC.
 2002 Orville Drive N.
 Ronkonkoma, NY 11779 U.S.A.

EATON
 9650 Jeronimo Rd.
 Irvine, CA 92618 U.S.A.

ELBIT AMERICA
 4700 Marine Creek Parkway
 Fort Worth, TX 76179 U.S.A.

ES3
 1346 Legend Hills Drive
 Clearfield, UT 84015 U.S.A.

FALCONS IN THE RAIN



U.S. Air Force maintainers work on an F-16 in the falling snow during the Cope Max Exercise in November 1985. The safety hazard caused by water pooling on the F-16's canopy in inclement weather led to the development of a coating solution called HydroSkip. (Image courtesy of the National Archives and Records Administration.)

By Patrick J. Walsh

With all of the threats the Lockheed Martin F-16 Fighting Falcon routinely faces in missions around the globe, it seems the last thing a Viper pilot would have to worry about is a rainstorm. But a growing volume of concerning feedback from F-16 operators, particularly in Europe and the Far East, implied otherwise. Based on their input, engineers at the U.S. Air Force Research Laboratory (AFRL) at Wright-Patterson Air Force Base in Ohio concluded that in certain circumstances, particularly at slower speed and a high angle of attack, inclement weather conditions can cause significant safety issues.

Problems arise when rapidly accumulating moisture builds up on a Falcon's canopy. If the aircraft's nose is up, as in a landing approach, pilots find that the pooling water can impair visibility. This can result in a wave off of the landing, necessitating another attempt at a lower angle and increased speed.

The solution, jointly developed by the AFRL and materials research scientists at the University of Dayton Research Institute, led to the introduction of a new product called HydroSkip in 2019. A protective liquid similar in consistency to common window cleaning products, HydroSkip is applied to the F-16 canopy at monthly intervals. With consistent use, it repels rain from the transparent surface, mitigating water pooling.

AFRL researchers chose the formula for HydroSkip from about twenty-five different options that they tested under laboratory conditions. The final product was then tested by the team at the U.S. Air Force Arnold Engineering Development Complex (AEDC) at their flight simulation facility at the Ames Research Center in Mountain View, California. The AEDC engineers developed wind tunnel rain simulation techniques to replicate the problem and test the HydroSkip solution. The product is now available to all U.S. Air Force F-16 maintainers.

Sources

Ahmad Helmy, "Inside The F-16 Cockpit's Golden Bubble Canopy," *Simple Flying*, December 2024, [simpleflying.com](https://www.simpleflying.com).

Jill Pickett, "NFAC tests solutions to poor pilot visibility in inclement weather," U.S. Air Force Safety Center press release, January 2021, [safety.af.mil](https://www.safety.af.mil).

Whitney Wetsig, "Air Force Research Laboratory develops product to provide F-16 pilots with better visibility during rainstorms," U.S. Air Force press release, August 2019, [af.mil](https://www.af.mil).

EXTANT AEROSPACE
1615 West NASA Blvd.
Melbourne, FL 32901 U.S.A.

FATIGUE TECHNOLOGY
401 Andover Park East
Seattle, WA 98188 U.S.A.

FDH DEFENSE AFTERMARKET
5200 Sheila St.
Commerce, CA 90040 U.S.A.

FLOATS & FUEL CELLS
4010 Pilot Drive
Memphis, TN 38118 U.S.A.
Contact: Kevin Brewer
kbrewer@ffcfuelcells.com
ffcfuelcells.com

901-842-7110



FFC is USAF Source-Approved for the manufacturing of both F-16 and C-130 fuel cells. In addition to manufacturing capabilities, FFC carries U.S. Government and OEM repair approvals with our FAA Repair Station TH4R544M. Setting the fuel cell standard for 49 years. See our advertisement on page 35.

FRAZIER AVIATION, INC.
445 North Fox St.
San Fernando, CA 91340 U.S.A.
Contact: Chris Fellows
cfellows@frazieraviation.com
www.frazieraviation.com

818-898-1998



For 72 years, Frazier Aviation, Inc., has been recognized globally as a high-quality manufacturer offering customers cost-effective, value-added spares and repairs. Trusted by the U.S. Government, aerospace primes, and international countries alike, Frazier provides fabricated components to military prints, current ECOs, and all required specifications. FAA repair station # QN3R795L. See our advertisement on page 5.

G&S TEST SOLUTIONS, LLC
520 Superior Commerce Point
Oviedo, FL 32765 U.S.A.

GALLEON EMBEDDED COMPUTING
1260 Pin Oak Rd., Ste. 205
Katy, TX 77494 U.S.A.

GASTOPS LTD
1011 Polytek Street
Ottawa, ON K1J 9J3 Canada

GE AVIATION
3290 Patterson Ave. S.E.
Grand Rapids, MI 49512 U.S.A.

GENERAL DYNAMICS
12450 Fair Lakes Cir.
Fairfax, VA 22033 U.S.A.

GLENAIR
1211 Air Way
Glendale, CA 91201 U.S.A.

GLOBAL FINISHING SOLUTIONS
12731 Norway Road
Osseo, WI 54758 U.S.A.

F-16 FUEL CELLS

USAF SOURCE APPROVED FOR F-16 AND C-130 FUEL CELLS

In addition to manufacturing capabilities, FFC carries US Government and OEM Repair Approvals with our FAA repair station **NO. TH4R544M.**

Setting the fuel cell standard for 49 years.

1-800-647-6148 | ffcfuelcells.com

GMS CORPORATION
1984 Isaac Newton Square West, Suite 104
Reston, VA 20190 U.S.A.

HELICOPTER TECH, INC.
452 Swedeland Road
King Of Prussia, PA 19406 U.S.A.

HHI CORPORATION
736 W. Harrisville Road
Ogden, UT 84404 U.S.A.

HONEYCOMB COMPANY OF AMERICA
1950 Limbus Ave.
Sarasota, FL 34243 U.S.A.

HOWELL INSTRUMENTS, INC.
8945 South Freeway
Fort Worth, TX 76140 U.S.A.

HYDRAULICS INTERNATIONAL, INC.
20961 Knapp Street
Chatsworth, CA 91311 U.S.A.

IAI NORTH AMERICA
13873 Park Center Rd, Suite 400N
Herndon, VA 20171 U.S.A.

IASA GROUP, LLC
1905 Production Road
Fort Wayne, IN 46808 U.S.A.

IBC MATERIALS & TECHNOLOGIES, LLC
823 Hendricks Drive
Lebanon, IN 46052 U.S.A.

IEE
13170 Telfair Ave.
Sylmar, CA 91342 U.S.A.

ILIAS SOLUTIONS
Raketstraat 60, Rue de la Fusée
1130 Brussels, BE Belgium

INNOVATIVE AEROSYSTEMS
720 Pennsylvania Drive
Exton, PA 19341 U.S.A.
Contact: Stacie Rine
srine@iascorp.com
www.iascorp.com

610-646-9800



Innovative Aerosystems delivers American made, advanced avionics for commercial, military, and business aviation. From next-generation flight decks and autothrottles to mission computers and air data systems, Innovative Aerosystems provides innovative, certified solutions while supporting legacy fleets worldwide.

INOVATI, INC.
1522 Cook Place
Santa Barbara, CA 93117 U.S.A.

INTEGRATED PROCUREMENT TECHNOLOGIES (IPT)
7230 Hollister Ave.
Goleta, CA 93117 U.S.A.

INTERCONNECT WIRING
5024 W. Vickery Blvd.
Fort Worth, TX 76107 U.S.A.

INTERNATIONAL PRECISION, INC.
9526 Vassar Ave.
Chatsworth, CA 91311 U.S.A.

THE FIGHTER AND THE QUAIL

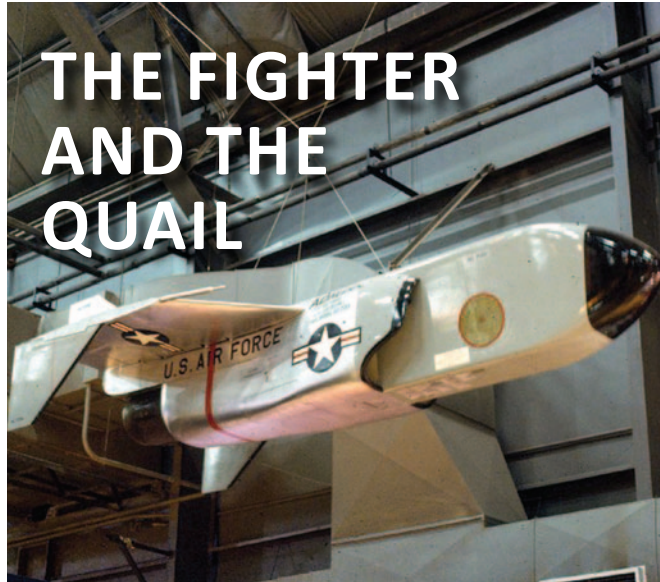

The General Electric J85 turbojet engine, which was integral to the success of Northrop's F-5A fighter aircraft, was originally designed for the ADM-20 Quail decoy cruise missile. This Quail is on display at the National Museum of the U.S. Air Force at Wright-Patterson Air Force Base in Ohio. (Image courtesy of the U.S. Air Force.)

By Patrick J. Walsh

In the long history of fighter design, few matches of airframe and engine have been more successful than the Northrop F-5A Freedom Fighter and the General Electric (GE) J85 turbojet. As these both progressed from engineering concept to working designs in the mid-1950s, the J85 became a key component in the ultimate emergence of the F-5A as a lightweight, cost-efficient export, prized by U.S. allies. The small, efficient turbojet engine subsequently became one of GE's most successful defense aircraft designs, with updated versions planned for continued use by the U.S. Air Force through 2040.

In its original incarnation, however, the J85 was not intended for use in a fighter plane. Fitting the requirement for a small but powerful engine that could power a large decoy missile, the J85 was initially designated for use in the ADM-20 Quail decoy cruise missiles, developed by McDonnell Aircraft Corporation for use with the Boeing B-52 Stratofortress bomber.

Carried in the B-52 for release in the event of a confrontation with Soviet ground-to-air missile sites at the height of the Cold War, the Quail decoy was outfitted with electronic equipment designed to confuse ground defense systems by mimicking the radar footprint of the B-52. The ADM-20 was deployed on B-52s throughout the 1960s.

Sources

T.A. Brisken, P.N. Howell, and A.C. Ewing, "J85 Rejuvenation Through Technology Insertion," Paper presented at the NATO Research and Technology Organization Applied Vehicle Technology lecture series, Atlantic City, New Jersey, October 2000, apps.dtic.mil.

"McDonnell ADM-20 Quail," National Museum of the U.S. Air Force Fact Sheet, nationalmuseum.af.mil.

Guy Norris, "T-38 engine upgrades set to extend trainer's life to 2040," *Flight Global*, April 2001, flightglobal.com.

"Northrop YF-5A Freedom Fighter," National Museum of the U.S. Air Force Fact Sheet, nationalmuseum.af.mil.

Ralph Vartabedian, "Era of the F-5 Ends After Three Decades," *Los Angeles Times*, January 1987, latimes.com.

ITI ENGINEERING
1081 Willa Springs Drive
Winter Springs, FL 32708 U.S.A.

J CHADWICK CO
1005 S. Mountain Ave.
Monrovia, CA 91016 U.S.A.

JAY-EM AEROSPACE CORPORATION
75 Marc Ave.
Cuyahoga Falls, OH 44223 U.S.A.

JDS INTERNATIONAL, INC.
15321 Herriman Blvd.
Noblesville, IN 46060 U.S.A.

KBR
1725 East 1450 South, Suite 240
Clearfield, UT 84015 U.S.A.

KEARFOTT CORPORATION GUIDANCE & NAVIGATION
DIVISIONSYSTEMS DIVISION
19 Chapin Road, Building C
Pine Brook, NJ 07058 U.S.A.

KIHOMAC, INC.
3800 N. Fairfield Road
Layton, UT 84041 U.S.A.

KINGS PEAK MFG.
2581 Rulon White Blvd.
Ogden, UT 84404 U.S.A.

KITCO DEFENSE
3577 S. Mountain Vista Parkway, Suite B
Provo, UT 84606 U.S.A.

KONGBERG AVIATION MAINTENANCE SERVICE A/S
Fetveien 80-84
Kjeller, Norway

L3HARRIS TECHNOLOGIES
7500 Maehr Road
Waco, TX 76715 U.S.A.

LEONARDO ELECTRONICS, INC.
2345 Crystal Drive
Arlington, VA 22202 U.S.A.

LIFE SUPPORT INTERNATIONAL, INC.
2250 Cabot Blvd. West, Suite 255
Langhorne, PA 19047 U.S.A.

LOCKHEED MARTIN
P. O. Box 748
Fort Worth, TX 76101 U.S.A.

LOCKHEED MARTIN AERONAUTICS COMPANY
86 South Cobb Drive
Marietta, GA 30063 U.S.A.

LOGISTIC SPECIALTIES, INC./LSI BUSINESS DEVELOPMENT
1530 N. Layton Hills Parkway, Suite 201
Layton, UT 84067 U.S.A.

MAC AEROSPACE CORP.
14558 Lee Rd.
Chantilly, VA 20151 U.S.A.

MARTIN-BAKER UK
Lower Road
Nr Uxbridge, Middlesex, UK UB9 5AJ United Kingdom

MARVIN GROUP 310-674-5030
261 W. Beach Ave.
Inglewood, CA 90302 U.S.A.
Contact: Shannon Sharpe
shannons@marvineng.com
www.marvingroup.com

The Marvin Group

The Marvin Group consists of Marvin Engineering (MEC), Marvin Test Solutions (MTS) and Marvin Land Systems (MLS). MEC produces military aircraft weapons suspension release equipment. Marvin Test Solutions produces armament test equipment and MLS supports APUs and ECUs for vehicles.

MARVIN TEST SOLUTIONS, INC. 949-263-2222
1770 Kettering
Irvine, CA 92614 U.S.A.
Contact: Jon Semancik
Jon.Semancik@MarvinTest.com
www.MarvinTest.com

MARVIN TEST SOLUTIONS

Marvin Test Solutions(MTS) is a vertically integrated aerospace test and measurement company that has delivered innovative solutions for factory, flightline, intermediate, and depot-level applications since 1988. A member of the Marvin Group, MTS has aircraft, armament, and munitions test solutions deployed worldwide supporting most U.S. aircraft and weapon systems.

See our advertisement on the inside front cover.

MAVEN ENGINEERING CORPORATION
15946 Derwood Road
Rockville, MD 20855 U.S.A.

MNEMONICS, INC.
3900 Dow Road
Melbourne, FL 32934 U.S.A.

MOHR TEST AND MEASUREMENT, LLC
2105 Henderson Loop
Richland, WA 99354 U.S.A.

MOOG, INC.
1213 North Main Street
Blacksburg, VA 24060 U.S.A.

NDT SOLUTIONS LLC
2601 E. 28th St.
Signal Hill, CA 90755 U.S.A.

NORTHERN AIR SYSTEMS
3605 Buffalo Road
Rochester, NY 14624 U.S.A.

NORTHROP GRUMMAN CORPORATION
1580 W. Nursery Road
Linthicum, MD 21090 U.S.A.

OGMA-INDUSTRIA AERONAUTICA DE PORTUGAL, SA
Parque Aeronautico de Alverca, Alverca do Ribatejo, V. F. de Xira, Alverca Do Ribatejo, PT 2615-173 Portugal

ONTIC, INC.
20400 Plummer Street
Chatsworth, CA 91311 U.S.A.

ORBIT ELECTRONICS GROUP
80 Cabot Court
Hauppauge, NY 11788 U.S.A.

ORKAL INDUSTRIES LLC
333 Westbury Ave.
Carle Place, NY 11514 U.S.A.

OSHKOSH AEROTECH
4074 S. 1900 W.
Roy, UT 84067 U.S.A.

PACIFIC COMPONENT EXCHANGE INC. (PCX)
17912 Gothard Street
Huntington Beach, CA 92647 U.S.A.

PACIFIC CONSOLIDATED INDUSTRIES (PCI)
12201 Magnolia Ave.
Riverside, CA 92503 U.S.A.

PARKER AEROSPACE
14300 Alton Parkway
Irvine, CA 92618 U.S.A.

PARTS AND REPAIR TECHNICAL SERVICES, INC.
210 Andrew Drive
Stockbridge, GA 30281 U.S.A.

PARTS AND REPAIR TECHNICAL SERVICES, INC.
210 Andrew Drive
Stockbridge, GA 30281 U.S.A.

PHOTO-SONICS, INC.
9131 Independence Ave.
Chatsworth, CA 91311 U.S.A.

PHT AEROSPACE
230 West Parkway
Pompton Plains, NJ 07444 U.S.A.

PRECISION AVIATION CONTROLS
101 Freedom Drive
Independence, KS 67301 U.S.A.

PRECISION AVIATION GROUP
495 Lake Mirror Road
Atlanta, GA 30349 U.S.A.

PSP SEALS, LLC
3702 Vanguard Drive
Fort Wayne, IN 46809 U.S.A.

RAMCO SYSTEMS CORPORATION
100 Overlook Center
Princeton, NJ 08540 U.S.A.

RAPTOR SCIENTIFIC
375 Jaffrey Road
Peterborough, NH 30458 U.S.A.



U.S. Air Force Colonel (retired) Charles B. DeBellevue is the top scoring U.S. flying ace of the Vietnam War, having achieved six victories over enemy aircraft during his wartime service. As a member of the two-man crew flying a McDonnell Douglas F-4 Phantom II, DeBellevue also became the first U.S. Air Force weapon systems officer (WSO) to be recognized as a flying ace. (Image courtesy of the U.S. Air Force.)

By Patrick J. Walsh

WHEN THE PHANTOM HELD ALL THE ACES

During the Vietnam War, five U.S. aviators were credited as flying aces, having been responsible for shooting down five or more enemy aircraft. All five achieved the feat while flying McDonnell Douglas F-4 Phantom IIs. In joining the ranks of celebrated aces of previous wars, the Phantom aviators also

helped to broaden the very definition of what it means to be an ace.

The concept of the ace—often romanticized in wartime press accounts and popularized in film and book portrayals of famous flyers—is as old as the practice of aerial dogfighting itself. French pilot Adolphe Pégoud was celebrated as the first-ever pilot to achieve “ace” status, after having shot down five enemy aircraft during World War I. Yet as aerial combat strategy evolved in various conflicts, the concept of a lone fighter pilot engaged in a one-on-one gunnery duel with an enemy aircraft was largely supplanted by advancements in technology, tactics, and weaponry.

The Phantom was designed for a crew of two: a pilot and, in U.S. Navy service, a radar intercept officer (RIO), or, in the U.S. Air Force, a weapon systems officer (WSO). As both crew members played a distinct and significant role in combat engagements, each received credit when an F-4 shot down an enemy aircraft.

The first WSO to be credited as a flying ace was Charles B. DeBellevue, who attained ace status during a mission on September 9, 1972. With six victories over enemy aircraft, DeBellevue is also the top American ace of the Vietnam War.

U.S. Navy Pilot Randy Cunningham and RIO William P. Driscoll each had separately participated in the downing of two enemy aircraft. On May 10, 1972, they attained ace status together during a single mission, when they shot down three North Vietnam Air Force MiG-17s, before their F-4 was hit with a missile. Forced to bail out of the badly damaged Phantom, Cunningham and Driscoll ejected over water near the Red River Delta, about 90 kilometers south of Hanoi, where they were rescued.

On August 28, 1972, R. Stephen Ritchie became the only U.S. Air Force pilot ace of the Vietnam War. During his second tour of duty, he destroyed the fifth of five MiG-21s that he shot down in a period of slightly more than three months.

On October 13, 1972, WSO Jeffrey Feinstein became the second U.S. Air Force flyer to achieve ace status, when he participated in the shootdown of a fifth MiG-21.

U.S. FLYING ACES OF THE VIETNAM WAR

NAME	BRANCH	ROLE	VICTORIES	FINAL VICTORY
Charles B. DeBellevue	USAF	Weapons Systems Officer (WSO)	6	September 9, 1972
Randy Cunningham	USN	Pilot	5	May 10, 1972
William P. Driscoll	USN	Radar Intercept Officer (RIO)	5	May 10, 1972
R. Stephen Ritchie	USAF	Pilot	5	August 28, 1972
Jeffrey Feinstein	USAF	Weapons Systems Officer (WSO)	5	October 13, 1972

Sources: Robert F. Dorr and Chris Bishop, eds. *Vietnam Air War Debrief*. London: Aerospace Publishing, 1996.; “Eagle Profile: Driscoll, William P.,” Gathering of Eagles Foundation, goefoundation.org.; L. Frank Futrell, et al., *United States Air Force in Southeast Asia: Aces and Aerial Victories, 1965-1973*, U.S. Air Force Air University Press, 1976, airuniversity.af.edu. Marshall L. Michel. *Clashes: Air Combat Over North Vietnam 1965-1972*, Annapolis, MD: Naval Institute Press, 2004.; “Profiles in Valor: Brigadier General Steve Ritchie, Flying Ace” (video), American Veterans Center, 2014, americanveteranscenter.org.; Stephen Sherman, “Randy Cunningham,” *Ace Pilots*, March 2012, acepilots.com.

RBC BEARINGS AEROSPACE
One Tribology Center
Oxford, CT 06478 U.S.A.

RHINESTAHL CTS
7687 Innovation Way
Mason, OH 45040 U.S.A.

RICHARD MANUFACTURING COMPANY
2147 N. Rulon White Blvd., Suite 212
Ogden, UT 84404 U.S.A.

ROHDE & SCHWARZ
6821 Benjamin Franklin Dr.
Columbia, MD 21046 U.S.A.

RSI, INC.
1670 Kohlers Crossing
Kyle, TX 78640 U.S.A.

RUAG AG
Seetalstrasse 175
Schweiz, CH 6032 Emmen Switzerland

S&K TECHNOLOGIES, INC. - AEROSPACE SERVICES
63066 Hwy. 93 N.
St. Ignatius, MT 59865 U.S.A.

SABCA
Chaussée de Haecht 1470
Brussels, 1130 Belgium

SABENA AEROSPACE
Brussels Airport Building 31
Brussels, 1930 Belgium

SAELIG COMPANY, INC.
71A Perinton Parkway
Fairport, NY 14450 U.S.A.

SAFRAN PASSENGER SOLUTIONS
1500 Glenn Curtiss St.
Carson, CA 90746 U.S.A.

SHERWOOD AVIATION
4690 N.W. 128th Street
Opa-Locka, FL 33054 U.S.A.

SIMTECH, INC.
66A Floydville Road
East Granby, CT 06026 U.S.A.

SNAP-ON, INCORPORATED
2801 80th Street
Kenosha, WI 53143 U.S.A.

SPARKCOGNITION GOVERNMENT SYSTEMS, INC.
12708 Riata Vista Cir., Suite A-116
Austin, TX 78727 U.S.A.

SPECMAT TECHNOLOGIES, INC.
215 Dunavant Drive
Rockford, TN 37853 U.S.A.

SPECTRA AEROSPACE & DEFENSE
6435 Shiloh Road
Alpharetta, GA 30005 U.S.A.

SRI INTERNATIONAL
201 Washington Road
Princeton, NJ 08540 U.S.A.

STACO SYSTEMS
7 Morgan
Irvine, CA 92618 U.S.A.

SUMMIT AEROSPACE
8130 N.W. 74 Ave.
Medley, FL 33166 U.S.A.

SURVITEC / RFD BEAUFORT INC.
1420 Wolf Creek Trail
Sharon Center, OH 44274 U.S.A.

TACTICAL AIR SUPPORT, INC.
11849 Aerospace Way
Jacksonville, FL 32221 U.S.A.

TASK AEROSPACE, INC.
4051 N. Higley Road
Mesa, AZ 85215 U.S.A.

TAT TECHNOLOGIES LTD
Gedera, Israel

TECHNOLOGY FOR ENERGY CORP
10737 Lexington Drive
Knoxville, TN 37932 U.S.A.

TERMA NORTH AMERICA
3200 Windy Hill Rd. S.E.
Atlanta, GA 30339 U.S.A.

TESTEK SOLUTIONS
28320 Lakeview Drive
Wixom, MI 48393 U.S.A.

THALES AVIONICS
1444 N. Farnsworth Ave.
Aurora, IL 60505 U.S.A.

TRANSAERO, INC
35 Melville Park Road
Melville, NY 11747 U.S.A.

TRANSHIELD, INC.
2932 Thorne Dr.
Elkhart, IN 46514 U.S.A.

TRELLEBORG SEALING SOLUTIONS
Johan Kocksgatan 10
Trelleborg, SE 231 22 Sweden

TRISOFT COVERS INC.
6549 Waterford Circle
Sarasota, FL 34238 U.S.A.

UNICAL DEFENSE, INC.
680 S. Lemon Ave.
City Of Industry, CA 91789 U.S.A.

VIAMI SOLUTIONS
10200 W. York St.
Wichita, KS 67215 U.S.A.

W L GORE & ASSOCIATES
201 Airport Road
Elkton, MD 21922 U.S.A.

WALL COLMONOY AEROBRAZE OKC
4700 S.E. 59th Street
Oklahoma City, OK 73135 U.S.A.

WESTEST ENGINEERING, CORP
2980 North Church Street
Layton, UT 84040 U.S.A.

WILLIAMS RDM, INC.
200 Greenleaf Street
Ft. Worth, TX 76107 U.S.A.

WORLDWIDE WAREHOUSE REDISTRIBUTION SERVICES
1940 Allbrook Drive
Wright-Patterson AFB, OH 45433-5337 U.S.A.

WRIGHT MEDIA, INC.
P.O. Box 110382
Naples, FL 34108 U.S.A.
Contact: Richard Greenwald
r.greenwald@wrightmediainc.com
www.wrightmediainc.com

914-244-8899



Wright Media publishes authoritative periodicals for the defense aviation aftermarket. “Aviation Aftermarket Defense”; “CONTACT!” magazine for the fighter and C-130 markets; the “Program Guide” for the F-16, HOC and C-130 TCG meetings, plus the “Wright Prospectors.” We communicate your message in print, in pixels and in person.

X TECHNOLOGIES, INC.
100 Sandau, Suite 300
San Antonio, TX 78216 U.S.A.

XTREME SEMICONDUCTOR
12908 Trails End Road
Leander, TX 78641 U.S.A.

ZIP-CHEM PRODUCTS
400 Jarvis Drive
Morgan Hill, CA 95037 U.S.A.

GET LISTED IN THE PROGRAM GUIDE - 2027 F-16 AND OTHER JETS

For advertising information please contact Richard Greenwald at 914-244-8899 or r.greenwald@wrightmediainc.com



Doing it right. Nonstop.™



Aftermarket expert. Trusted partner. Global expertise.

Services

- OEM part distribution
- Component repair & overhaul
- Serviceable & OEM factory-new parts
- Depot level training
- Test stands & support equipment
- F-16 aircraft maintenance (MRO)
- Repair management
- Logistics support services
- Engineering solutions
- Supply chain management

Contact information

OEM Distribution – Defense
+1-630-227-2000 / F: +1-630-227-2039

Component Services – Amsterdam
+31-23-800-0600 / Email: F-16@aarcorp.com

Component Services – Grand Prairie
+1-972-623-9300 / Email: F-16@aarcorp.com

Component Services – Wellington
+1-620-326-2235 / Email: F-16@aarcorp.com

For a full listing of our services visit aarcorp.com or email F-16@aarcorp.com

OEM partners

