

# TOP LINE

PROCESS EQUIPMENT COMPANY

A Full Line of  
Stainless Steel Flow Control Equipment for the Food,  
Beverage, and Dairy Processing Industries



PUMPS · VALVES · FITTINGS · TUBING  
CUSTOM FABRICATIONS

[www.toplineonline.com](http://www.toplineonline.com)

# Table of Contents

Type a short URL example (topln.co/bpeproducts) into your web browser to view product information. For further explanation, see the bottom of page 2.

|   |              |
|---|--------------|
| <b>Introduction</b> .....   | <b>1-3</b>   |
| <b>Clamp Fittings</b> .....   | <b>4-14</b>  |
| topln.co/clampfittings   topln.co/clampspsi   topln.co/rocket   |              |
| <b>Butt weld Fittings</b> .....   | <b>15-18</b> |
| topln.co/sweld  |              |
| <b>Tube O.D. Butt weld Fittings</b> .....   | <b>19-23</b> |
| topln.co/odweld   |              |
| <b>Bevel Seat, TI-Line, John Perry Fittings</b> .....   | <b>24</b>    |
| topln.co/bevel   topln.co/ti   topln.co/johnperry   |              |
| <b>TOP-FLO® Valves &amp; Automation</b> .....   | <b>25-38</b> |
| topln.co/butterfly   topln.co/ballvalves   topln.co/3way   topln.co/vport   topln.co/rpa   topln.co/ea<br>topln.co/ca   topln.co/check   topln.co/plug   topln.co/dcx   topln.co/pmoc   topln.co/relief<br>topln.co/diaphragmvalves   topln.co/sample   topln.co/ballcheck   topln.co/airblow |              |
| <b>Tubing &amp; Hangers</b> .....   | <b>39-40</b> |
| topln.co/hangers   topln.co/hangerscast   topln.co/hangersdual   topln.co/hangersquad   |              |
| <b>Custom Fabrications, Electropolishing</b> .....  | <b>41</b>    |
| topln.co/custom   topln.co/electropolishing   |              |
| <b>TOP-FLO® Filters &amp; Strainers</b> .....   | <b>42-43</b> |
| topln.co/strainers  |              |
| <b>Gauges &amp; Sight Glasses</b> .....   | <b>44-45</b> |
| topln.co/gauges   topln.co/sight  |              |
| <b>Pumps/Dolly &amp; Replacement Kits</b> .....   | <b>46-53</b> |
| topln.co/cent   topln.co/pumpmanual   topln.co/curves   topln.co/kits   topln.co/pumpdata<br>topln.co/datasheet   topln.co/dolly   topln.co/air   |              |
| <b>BPE Products</b> .....   | <b>54-56</b> |
| topln.co/bpe  |              |
| <b>Allegheny Bradford Family of Companies</b> .....   | <b>57</b>    |



Top Line Process Equipment Company is a leading supplier of sanitary stainless steel process equipment. For over 50 years we've provided our customers with exceptional customer service and quality products. We market through a world-wide network of distributors and large OEM's. Top Line's involvement with its distributors includes not only providing competitively priced products but to support an ongoing line of communication between ourselves and the ultimate end user of the product. We provide full factory and technical support to our customers along with both customer and project leads.

Our modern, well equipped manufacturing facilities are staffed by our skilled and dedicated craftsmen. Consistently meeting important tolerances and finish specifications is of primary concern to us. Before any products leave our plant, they are subjected to rigid quality assurance checks. Top Line should always be considered your first choice for both standard and custom fabricated stainless steel products.

We are committed to meeting the fastest delivery, new product development and application engineering to meet all our customer's needs with our extensive inventory and expert sales team.

**Stainless Steel**

In metallurgy, stainless steel encompasses the broad classification of iron-base alloys (50% minimum iron) containing at least 10% chromium that are known for their excellent corrosion and heat resistance. Other elements are also added to form alloys for special purposes, in addition to the corrosion resistance imparted by chromium content. Some of these elements are: nickel for increased corrosion resistance, ductility and workability; molybdenum for increased corrosion resistance, and particularly resistance to pitting, increased creep strength and high temperature strength; columbium and titanium for stabilization; sulfur and selenium for improved machinability. There are many different grades of stainless steel with various surface finishes available to suit specific process applications. The most commonly used grades of stainless steel in hygienic piping systems are provided in the table below.

**Austenitic Stainless Steel Chemistry**

| Grade | C    | Mn   | P     | S     | Si   | Cr        | Ni        | Mo      |
|-------|------|------|-------|-------|------|-----------|-----------|---------|
| 304   | 0.08 | 2.00 | 0.045 | 0.030 | 1.00 | 18.0-20.0 | 8.0-10.0  |         |
| 316L  | 0.03 | 2.00 | 0.045 | 0.030 | 1.00 | 16.0-18.0 | 10.0-14.0 | 2.0-3.0 |

Please reference our high purity catalog at [topln.co/BPE](http://topln.co/BPE) for 316L BPE chemistry per the American Society of Mechanical Engineers.



## Surface Finish

Surface finish improvement (polishing) is a mechanical process that reduces or eliminates material surface imperfections and allows increased clean-ability of components used within a hygienic piping system. The internal (ID) and external (OD) surfaces of product contact components can be improved using several methods including but not limited to mechanical polishing, cold working, and machining.

$R_a$  ( $\mu\text{in.}$ ) is a numerical expression of measured surface roughness or texture, typically, of a polished or machined metal surface. Measurements are taken with a profilometer or other means.  $R_a$  ( $\mu\text{in.}$ ) values can also be converted to  $R_a$  ( $\mu\text{m}$ ).

Mill finish is an unpolished material surface that can pertain to tubing, fittings, and other system components. Top Line mill finish tubing is bright annealed and will have a silvery satin appearance. Top Line mill finish fittings are tumbled and will have a medium gray appearance.

## Finish Designations for Stainless Steel Tubing and Fittings

| Finish Number | Part Number | Finish Conditions – <b>Inside Diameter</b> | Finish Conditions – <b>Outside Diameter</b> |
|---------------|-------------|--|---|
| 1             | -1          | Mill finish – Unpolished                   | Mill finish – Unpolished                    |
| 3             | -3          | Mechanical Polish                          | Mill finish – Unpolished                    |
| 5             | -5          | Mill finish – Unpolished                   | Mechanical Polish                           |
| 7             | -7          | Mechanical Polish                          | Mechanical Polish                           |

Please reference our High Purity Catalog at [topln.co/BPE](http://topln.co/BPE) for surface finishes designated by the American Society of Mechanical Engineers.

## Industry Standards

**3-A Sanitary Standards Inc.** is an independent, not-for-profit corporation dedicated to advancing hygienic equipment design for the food, beverage, and pharmaceutical industries. They represent the interests of food processors, regulatory sanitarians, and equipment fabricators with a common commitment to promoting food safety and the public health. Many of our products are 3-A certified.

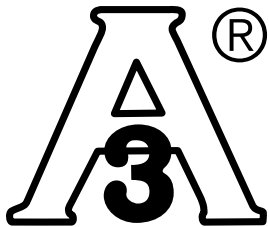

The 3-A Symbol is a registered mark used to identify equipment that meets 3-A Sanitary Standards for sanitary design and fabrication. All equipment displaying the 3-A Symbol must pass a comprehensive, independent Third Party Verification (TPV) inspection to assure it meets the sanitary design criteria in a 3-A Sanitary Standard. Use of the 3-A Symbol is subject to specific conditions established by 3-A SSI.

## Website URL Shortening

This catalog includes website URLs on every page to give you immediate access to the most up-to-date and detailed information available specific to the product you are reviewing. The website addresses (URLs) in this catalog have been shortened for your convenience and will direct you to information about the products you are viewing on the catalog page. For example, the C-Series pumps page includes [topln.co/curves](http://topln.co/curves), which you can type into your web browser to immediately view the pump curves for the C-Series pumps. Please call 1-800-458-6095 if you have any questions.

## Sanitary Tube

| Tube OD | Tube ID | Wall Thickness | Weight Dry | Volume     | Weight w/Water | Flow at a Mean Velocity<br>Gallons Per Minute |         |          |
|---------|---------|----------------|------------|------------|----------------|---|---------|----------|
|         |         |                |            |            |                | 5ft/sec                                       | 7ft/sec | 10ft/sec |
| Inches  | Inches  | Inches         | lbs/100 ft | gal/100 ft | lbs/100 ft     |   |         |          |
| 1/2     | 0.370   | 0.065          | 30.6       | 0.560      | 35.3           | 1.70  | 2.30    | 3.40     |
| 3/4     | 0.620   | 0.065          | 48.2       | 1.570      | 61.3           | 4.70  | 6.60    | 9.40     |
| 1       | 0.870   | 0.065          | 65.8       | 3.090      | 91.5           | 9.30  | 13.00   | 19.00    |
| 1-1/2   | 1.370   | 0.065          | 100.9      | 7.660      | 164.8          | 23.00   | 32.00   | 46.00    |
| 2       | 1.870   | 0.065          | 136.1      | 14.270     | 255.1          | 43.00   | 60.00   | 86.00    |
| 2-1/2   | 2.370   | 0.065          | 171.2      | 22.920     | 362.4          | 69.00   | 96.00   | 138.00   |
| 3       | 2.870   | 0.065          | 206.4      | 33.600     | 486.7          | 101.00  | 141.00  | 202.00   |
| 4       | 3.834   | 0.083          | 351.8      | 59.970     | 851.9          | 180.00  | 252.00  | 360.00   |
| 6       | 5.782   | 0.109          | 694.7      | 136.390    | 1832.2         | 409.00  | 573.00  | 818.00   |
| 8       | 7.782   | 0.109          | 930.6      | 247.070    | 2991.1         | 741.00  | 1038.00 | 1482.00  |

## Water Data and Formulas

Pounds/square inch at bottom of water column = height of column in feet x 0.434

1 gallon water = 231 cubic inches = 8.33 pounds

1 pound water = 27.7 cubic inches

1 cubic foot water = 7.5 gallons = 62.5 pounds

1 cubic foot salt water = 7.5 gallons = 64.3 pounds

## Pressure Measurement

Column of water 12" high and 1" in Diameter = 0.341 lbs

1 pound/square inch = 144 pounds/ft<sup>2</sup> = 0.068 Atmosphere = 2.042" Mercury at 62°F =  
27.7" water at 62°F = 2.31' water at 62°F.

1 Atmosphere = 30" Mercury at 62°F = 14.7 lbs/square inch = 2116.3 lbs/square foot =  
33.95' of Water at 62°F

1' Water at 62°F = 62.355 lbs/square foot = 0.433 lbs/square inch

1" Mercury at 62°F = 1.132' Water = 13.58" Water = 0.491 lbs/square inch

## Other useful links

[topln.co/glossary](http://topln.co/glossary)

[topln.co/conversion tables](http://topln.co/conversion tables)



# Clamp Fittings

Top Line precision crafted clamp fittings provide fast, sanitary and secure connections. Polished fittings come standard with the No. 7 ID/OD finish (32R<sub>a</sub> ID/OD) finish which meets or exceeds FDA and 3-A regulatory standards.

## Specifications:

Size Range: 1/2" OD - 12" OD

Wall Thickness: .065 (1/2" - 3")  
 .083 (4")  
 .109 (6" - 8")  
 .109 (10" - 12")

**Materials:** 304 (Stock No. prefix 32) as shown in part number matrix

316L (Stock No. prefix 38) as shown in part number matrix

Other materials grades are available upon request



## 2CMP – Elbow 90° Clamp Ends (3-A) 32R<sub>a</sub> ID/32R<sub>a</sub> OD

| SIZE (TUBE O.D.) | A      | R     | 304 STOCK NO. | 316L STOCK NO. |
|------------------|--------|-------|---------------|----------------|
| 1/2              | 3-1/2  | 1-1/8 | -             | 38705-7        |
| 3/4              | 3-1/2  | 1-1/8 | -             | 38707-7        |
| 1                | 2      | 1-1/2 | 32710-7       | 38710-7        |
| 1-1/2            | 2-3/4  | 2-1/4 | 32715-7       | 38715-7        |
| 2                | 3-1/2  | 3     | 32720-7       | 38720-7        |
| 2-1/2            | 4-1/4  | 3-3/4 | 32725-7       | 38725-7        |
| 3                | 5      | 4-1/2 | 32730-7       | 38730-7        |
| 4                | 6-5/8  | 6     | 32740-7       | 38740-7        |
| 6                | 9-3/4  | 9     | 32760-7       | 38760-7        |
| 8                | 12-7/8 | 12    | 32780-7       | 38780-7        |
| 10               | 15-7/8 | 15    | 327100-7      | 387100-7       |
| 12               | 19     | 18    | 327120-7      | 387120-7       |

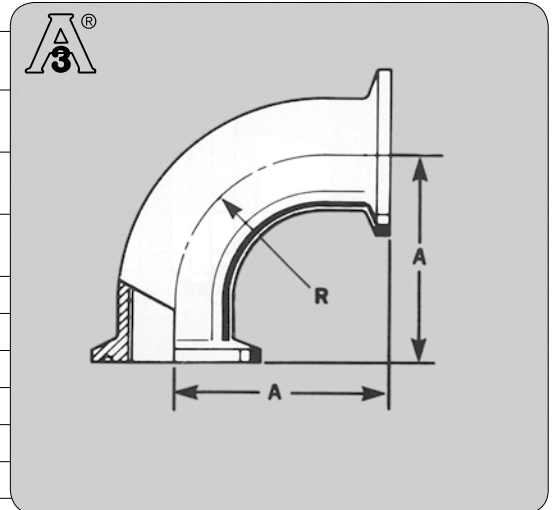

## 2FMP – 14 Elbow 90° Clamp End x Bevel Seat Plain End with Hex Nut (3-A) 32R<sub>a</sub> ID/ 32R<sub>a</sub> OD

| SIZE (TUBE O.D.) | A     | B       | 304 STOCK NO. |
|------------------|-------|---------|---------------|
| 1                | 2     | 2-3/16  | 327010        |
| 1-1/2            | 2-3/4 | 2-31/32 | 327015        |
| 2                | 3-1/2 | 3-23/32 | 327020        |
| 2-1/2            | 4-1/4 | 4-19/32 | 327025        |
| 3                | 5     | 5-13/32 | 327030        |
| 4                | 6-5/8 | 7-7/32  | 327040        |

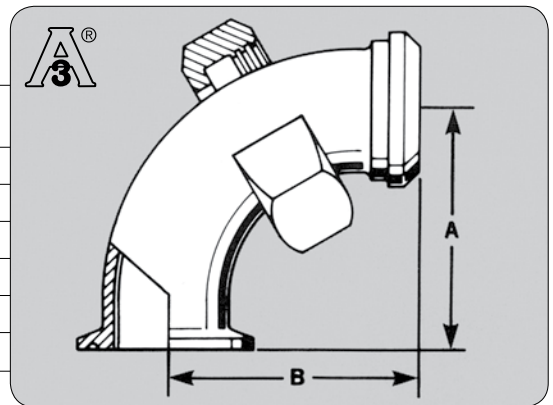

## 2FMP – 15 Elbow 90° Clamp End x Bevel Seat Threaded End (3-A) 32R<sub>a</sub> ID/32R<sub>a</sub> OD

| SIZE (TUBE O.D.) | A     | B       | 304 STOCK NO. |
|------------------|-------|---------|---------------|
| 1                | 2     | 2-3/16  | 327110        |
| 1-1/2            | 2-3/4 | 2-31/32 | 327115        |
| 2                | 3-1/2 | 3-31/32 | 327120        |
| 2-1/2            | 4-1/4 | 4-19/32 | 327125        |
| 3                | 5     | 5-13/32 | 327130        |
| 4                | 6-5/8 | 7-7/32  | 327140        |

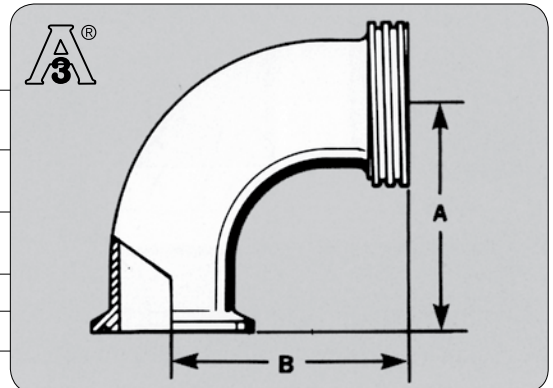

NOTE: 1" CLAMP FITTINGS USE 1-1/2" CLAMPS

[topln.co/clampfittings](http://topln.co/clampfittings)

## 2CMP – 31MP Elbow 90° Reducing Concentric Clamp End x Clamp End (3-A) 32R<sub>a</sub> ID/32R<sub>a</sub> OD

| SIZE<br>(TUBE O.D.) | A    | B    | 304<br>STOCK NO. | 316L<br>STOCK NO. |
|---------------------|------|------|------------------|-------------------|
| 1-1/2 X 1           | 2.00 | 2.00 | 327215           | 387215            |
| 2 X 1               | 2.00 | 2.00 | 327220           | 387220            |
| 2 X 1-1/2           | 2.75 | 2.75 | 327220A          | 387220A           |
| 2-1/2 X 1           | 2.00 | 2.00 | 327225B          | 387225B           |
| 2-1/2 X 1-1/2       | 2.75 | 2.75 | 327225           | 387225            |
| 2-1/2 X 2           | 3.50 | 3.50 | 327225A          | 387225A           |
| 3 X 1               | 2.00 | 2.00 | 327230C          | 387230C           |
| 3 X 1-1/2           | 2.75 | 2.75 | 327230           | 387230            |
| 3 X 2               | 3.50 | 3.50 | 327230A          | 387230A           |
| 3 X 2-1/2           | 4.25 | 4.25 | 327230B          | 387230B           |
| 4 X 1-1/2           | 2.88 | 2.75 | 327240C          | 387240C           |
| 4 X 2               | 3.63 | 3.50 | 327240B          | 387240B           |
| 4 X 2-1/2           | 4.38 | 4.25 | 327240           | 387240            |
| 4 X 3               | 5.13 | 5.00 | 327240A          | 387240A           |

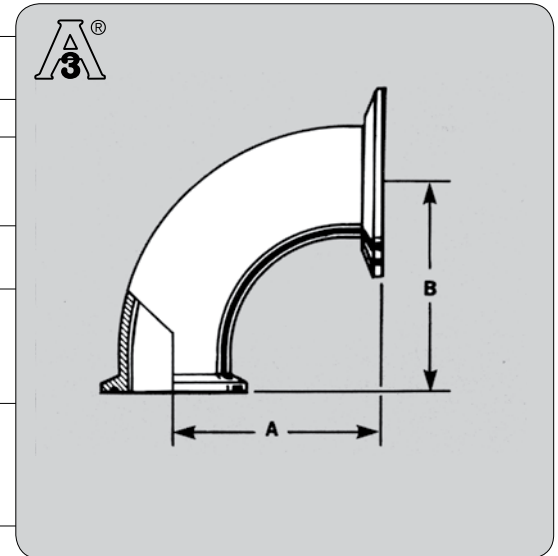

## 2FMP-31MP – Elbow 90° Reducing Concentric Clamp End x Bevel Seat Plain End (3-A) 32R<sub>a</sub> ID/32R<sub>a</sub> OD

| SIZE<br>(TUBE O.D.) | A     | B       | 304<br>STOCK NO. |
|---------------------|-------|---------|------------------|
| 2 X 1               | 2     | 1-9/16  | 327420           |
| 2 X 1-1/2           | 2-3/4 | 2-5/16  | 327420A          |
| 2-1/2 X 1-1/2       | 2-3/4 | 2-5/16  | 327425           |
| 2-1/2 X 2           | 3-1/2 | 3-1/16  | 327425A          |
| 3 X 1-1/2           | 2-3/4 | 2-5/16  | 327430           |
| 3 X 2               | 3-1/2 | 3-1/16  | 327430A          |
| 3 X 2-1/2           | 4-1/4 | 3-13/16 | 327430B          |
| 4 X 2-1/2           | 4-1/4 | 3-13/16 | 327440           |
| 4 X 3               | 5     | 4-9/16  | 327440A          |

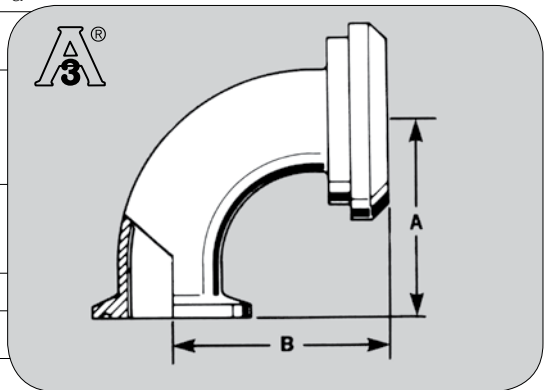

## 2KMP – Elbow 45° Clamp Ends (3-A) 32R<sub>a</sub> ID/32R<sub>a</sub> OD

| SIZE<br>(TUBE O.D.) | A      | R     | 304<br>STOCK NO. | 316L<br>STOCK NO. |
|---------------------|--------|-------|------------------|-------------------|
| 1/2                 | 2-3/4  | 1-1/8 | -                | 38805-7           |
| 3/4                 | 2-3/4  | 1-1/8 | -                | 38807-7           |
| 1                   | 1-1/8  | 1-1/2 | 32810-7          | 38810-7           |
| 1-1/2               | 1-7/16 | 2-1/4 | 32815-7          | 38815-7           |
| 2                   | 1-3/4  | 3     | 32820-7          | 38820-7           |
| 2-1/2               | 2-1/16 | 3-3/4 | 32825-7          | 38825-7           |
| 3                   | 2-3/8  | 4-1/2 | 32830-7          | 38830-7           |
| 4                   | 3-1/8  | 6     | 32840-7          | 38840-7           |
| 6                   | 4-1/2  | 9     | 32860-7          | 38860-7           |
| 8                   | 5-7/8  | 12    | 32880-7          | 38880-7           |
| 10                  | 7-1/8  | 15    | -                | -                 |
| 12                  | 8-1/2  | 18    | -                | -                 |

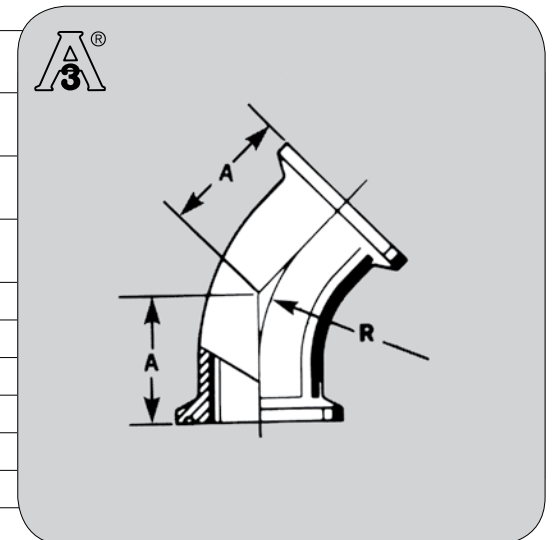

7MP – Tee Clamp Ends (3-A) 32R<sub>a</sub> ID/32R<sub>a</sub> OD

| SIZE<br>(TUBE O.D.) | A     | B      | 304<br>STOCK NO. | 316L<br>STOCK NO. |
|---------------------|-------|--------|------------------|-------------------|
| 1/2                 | 2-5/8 | 5-1/4  | -                | 381105-7          |
| 3/4                 | 2-5/8 | 5-1/4  | -                | 381107-7          |
| 1                   | 2-3/8 | 4-3/4  | 321110-7         | 381110-7          |
| 1-1/2               | 2-3/4 | 5-1/2  | 321115-7         | 381115-7          |
| 2                   | 3-1/2 | 7      | 321120-7         | 381120-7          |
| 2-1/2               | 3-1/2 | 7      | 321125-7         | 381125-7          |
| 3                   | 3-3/4 | 7-1/2  | 321130-7         | 381130-7          |
| 4                   | 4-1/2 | 9      | 321140-7         | 381140-7          |
| 6                   | 5-3/4 | 11-1/2 | 321160-7         | 381160-7          |
| 8                   | 7-7/8 | 15-3/4 | 321180-7         | 381180-7          |
| 10                  | 9-3/8 | 18-3/4 | 3211100-7        | 3811100-7         |
| 12                  | 11    | 22     | 3211120-7        | 3811120-7         |

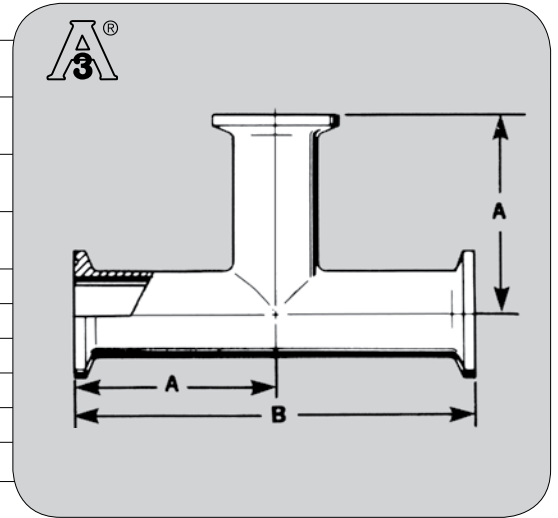

NOTE: 1" CLAMP FITTINGS USE 1-1/2" CLAMPS

7RMP – Tee Reducing Clamp Ends (3-A) 32R<sub>a</sub> ID/32R<sub>a</sub> OD

| SIZE<br>(TUBE O.D.) | A       | B       | C       | 304<br>STOCK NO. | 316L<br>STOCK NO. |
|---------------------|---------|---------|---------|------------------|-------------------|
| 3/4 X 1/2           | 5       | 2-1/2   | 2-1/2   | -                | 381107R05-7       |
| 1 X 1/2             | 5-1/4   | 2-5/8   | 2-5/8   | -                | 381110R05-7       |
| 1 X 3/4             | 5-1/4   | 2-5/8   | 2-5/8   | -                | 381110R07-7       |
| 1-1/2 X 1/2         | 5-3/4   | 2-7/8   | 2-7/8   | -                | 381115R05-7       |
| 1-1/2 X 3/4         | 5-3/4   | 2-7/8   | 2-7/8   | -                | 381115R07-7       |
| 1-1/2 X 1           | 4-5/16  | 2-5/32  | 1-7/8   | 321115R10        | 381115R10         |
| 2 X 1/2             | 6-3/4   | 3-3/8   | 3-1/8   | -                | 381120R05-7       |
| 2 X 3/4             | 6-3/4   | 3-3/8   | 3-1/8   | -                | 381120R07-7       |
| 2 X 1               | 5-1/8   | 2-9/16  | 2-1/8   | 321120R10        | 381120R10         |
| 2 X 1-1/2           | 5-1/8   | 2-9/16  | 2-13/32 | 321120R15        | 381120R15         |
| 2-1/2 X 1           | 5-11/16 | 2-27/32 | 2-13/16 | -                | 381125R10         |
| 2-1/2 X 1-1/2       | 5-11/16 | 2-27/32 | 2-13/16 | 321125R15        | 381125R15         |
| 2-1/2 X 2           | 5-11/16 | 2-27/32 | 2-13/16 | 321125R20        | 381125R20         |
| 3 X 1               | 6-3/16  | 3-3/32  | 3-1/16  | 321130R10        | 381130R10         |
| 3 X 1-1/2           | 6-3/16  | 3-3/32  | 3-1/16  | 321130R15        | 381130R15         |
| 3 X 2               | 6-3/16  | 3-3/32  | 3-1/16  | 321130R20        | 381130R20         |
| 3 X 2-1/2           | 6-3/16  | 3-3/32  | 3-3/32  | 321130R25        | 381130R25         |
| 4 X 1               | 8-1/8   | 4-1/16  | 4-7/8   | -                | 381140R10         |
| 4 X 1-1/2           | 8-1/8   | 4-1/16  | 4-7/8   | 321140R15        | 381140R15         |
| 4 X 2               | 8-1/8   | 4-1/16  | 4-7/8   | 321140R20        | 381140R20         |
| 4 X 2-1/2           | 8-1/8   | 4-1/16  | 4-7/8   | 321140R25        | 381140R25         |
| 4 X 3               | 8-1/8   | 4-1/16  | 4-7/8   | 321140R30        | 381140R30         |
| 6 X 3               | 11-1/2  | 5-3/4   | 5-1/2   | 321160R30-7      | 381160R30-7       |
| 6 X 4               | 11-1/2  | 5-3/4   | 5-5/8   | 321160R40-7      | 381160R40-7       |
| 8 X 3               | 15-3/4  | 7-7/8   | 7-1/2   | -                | 381180R30-7       |
| 8 X 4               | 15-3/4  | 7-7/8   | 7-5/8   | 321180R40-7      | 381180R40-7       |
| 8 X 6               | 15-3/4  | 7-7/8   | 7-3/4   | 321180R60-7      | 381180R60-7       |
| 10 X 3              | 18-3/4  | 9-3/8   | 9       | -                | -                 |
| 10 X 4              | 18-3/4  | 9-3/8   | 9-1/8   | -                | -                 |
| 10 X 6              | 18-3/4  | 9-3/8   | 9-1/4   | -                | -                 |
| 10 X 8              | 18-3/4  | 9-3/8   | 9-3/8   | 3211100R80-7     | -                 |
| 12 X 3              | 22      | 11      | 10-1/2  | -                | -                 |
| 12 X 4              | 22      | 11      | 10-5/8  | 3211120R40-7     | -                 |
| 12 X 6              | 22      | 11      | 10-3/4  | 3211120R60-7     | -                 |
| 12 X 8              | 22      | 11      | 10-7/8  | -                | -                 |
| 12 X 10             | 22      | 11      | 10-7/8  | -                | -                 |

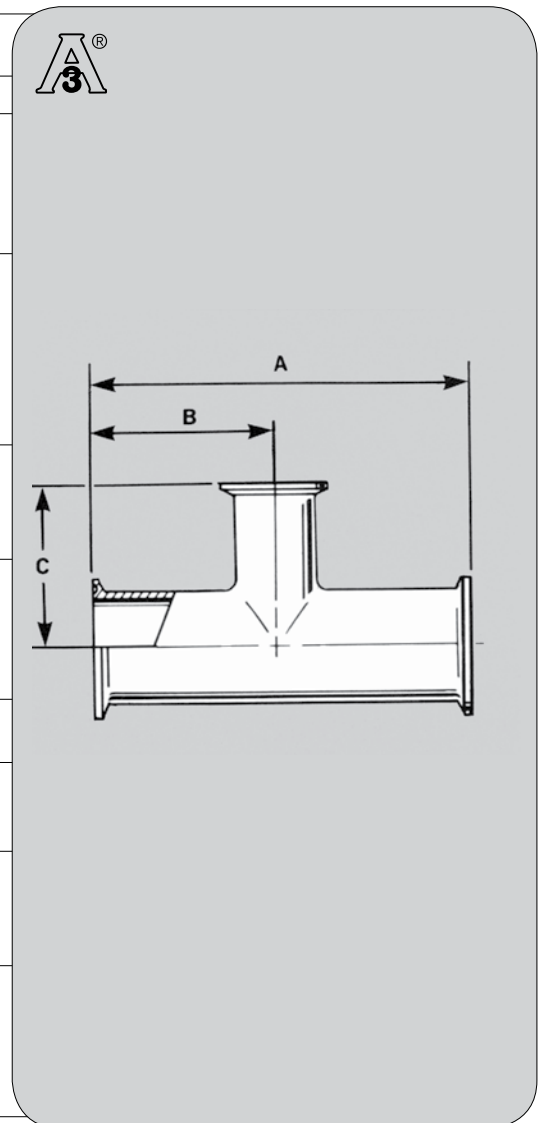



## L14AM7 – Ferrule Medium Clamp End x Weld End (3-A) 32R<sub>a</sub> ID/32R<sub>a</sub> OD

| SIZE<br>(TUBE O.D.) | A     | B      | C     | 304<br>STOCK NO. | 316L<br>STOCK NO. |
|---------------------|-------|--------|-------|------------------|-------------------|
| 1/2                 | 1-1/8 | .370   | 1/2   | -                | 387505            |
| 3/4                 | 1-1/8 | .620   | 3/4   | -                | 387507            |
| 1                   | 1-1/8 | .870   | 1     | 327510           | 387510            |
| 1-1/2               | 1-1/8 | 1.370  | 1-1/2 | 327515           | 387515            |
| 2                   | 1-1/8 | 1.870  | 2     | 327520           | 387520            |
| 2-1/2               | 1-1/8 | 2.370  | 2-1/2 | 327525           | 387525            |
| 3                   | 1-1/8 | 2.870  | 3     | 327530           | 387530            |
| 4                   | 1-1/8 | 3.834  | 4     | 327540           | 387540            |
| 6                   | 1-1/2 | 5.782  | 6     | 327560           | 387560            |
| 8                   | 1-1/2 | 7.782  | 8     | 327580           | 387580            |
| 10                  | 1-1/2 | 9.732  | 10    | 3275100          | 3875100           |
| 12                  | 1-1/2 | 11.732 | 12    | 3275120          | 3875120           |

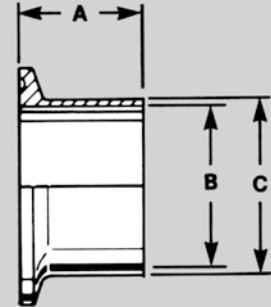

NOTE: 1" CLAMP FITTINGS USE 1-1/2" CLAMPS

## 14RMP – Ferrule Recessless x Clamp End (3-A) 32R<sub>a</sub> OD

| SIZE<br>(TUBE O.D.) | A      | B     | 304<br>STOCK NO. | 316L<br>STOCK NO. |
|---------------------|--------|-------|------------------|-------------------|
| 1                   | 3/4    | 1     | 32110            | 38110             |
| 1-1/2               | 1-1/8  | 1-1/2 | 32115            | 38115             |
| 2                   | 1-5/16 | 2     | 32120            | 38120             |
| 2-1/2               | 1-3/8  | 2-1/2 | 32125            | 38125             |
| 3                   | 1-7/16 | 3     | 32130            | 38130             |
| 4                   | 1-1/2  | 4     | 32140            | 38140             |

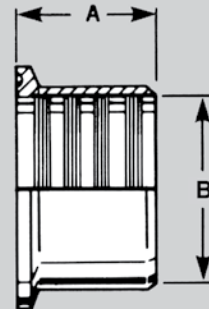

## 14MPW – Ferrule Tank Spud Clamp End x Weld End (3-A) 32R<sub>a</sub> ID/32R<sub>a</sub> OD

| SIZE<br>(TUBE O.D.) | A       | B     | C     | 304<br>STOCK NO. | 316L<br>STOCK NO. | 316L/SA-479<br>STOCK NO. |
|---------------------|---------|-------|-------|------------------|-------------------|--------------------------|
| 1                   | 1-5/8   | .870  | 1.160 | 327610           | 387610            | 387610-479               |
| 1-1/2               | 1-5/8   | 1.370 | 1.676 | 327615           | 387615            | 387615-479               |
| 2                   | 1-3/4   | 1.870 | 2.192 | 327620           | 387620            | 387620-479               |
| 2-1/2               | 1-3/4   | 2.370 | 2.708 | 327625           | 387625            | 387625-479               |
| 3                   | 1-13/16 | 2.870 | 3.224 | 327630           | 387630            | 387630-479               |
| 4                   | 2-1/8   | 3.834 | 4.256 | 327640           | 387640            | 387640-479               |

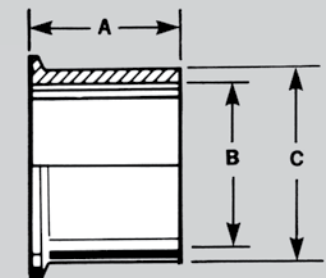

# Ferrules, & Cross

## Clamp Fittings



### 14WLMP – Ferrule Tank Spud Light Clamp End x Weld End (3-A) 32R<sub>a</sub> ID/32R<sub>a</sub> OD

| SIZE (TUBE O.D.) | A | B      | C     | 304 STOCK NO. | 316L STOCK NO. |
|------------------|---|--------|-------|---------------|----------------|
| 1                | 3 | .870   | 1     | 327710        | 387710         |
| 1-1/2            | 3 | 1.370  | 1-1/2 | 327715        | 387715         |
| 2                | 3 | 1.870  | 2     | 327720        | 387720         |
| 2-1/2            | 3 | 2.370  | 2-1/2 | 327725        | 387725         |
| 3                | 4 | 2.870  | 3     | 327730        | 387730         |
| 4                | 4 | 3.834  | 4     | 327740        | 387740         |
| 6                | 6 | 5.782  | 6     | 327760-7      | 387760-7       |
| 8                | 6 | 7.782  | 8     | 327780-7      | 387780-7       |
| 10               | 6 | 9.782  | 10    | 3277100-7     | 3877100-7      |
| 12               | 6 | 11.782 | 12    | 3277120-7     | 3877120-7      |

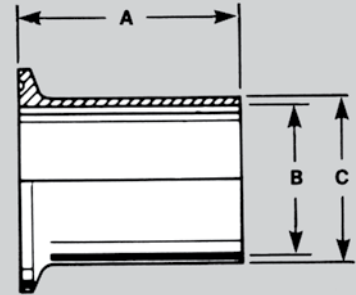

SA-479 material available upon request

### 14WMP – Ferrule Short Clamp End x Weld End (3-A) 32R<sub>a</sub> ID/32R<sub>a</sub> OD

| SIZE (TUBE O.D.) | A   | B      | C     | 304 STOCK NO. | 316L STOCK NO. |
|------------------|-----|--------|-------|---------------|----------------|
| 1/2              | 1/2 | .370   | 1/2   | -             | 38205          |
| 3/4              | 1/2 | .620   | 3/4   | -             | 38207          |
| 1                | 1/2 | .870   | 1     | 32210         | 38210          |
| 1-1/2            | 1/2 | 1.370  | 1-1/2 | 32215         | 38215          |
| 2                | 1/2 | 1.870  | 2     | 32220         | 38220          |
| 2-1/2            | 1/2 | 2.370  | 2-1/2 | 32225         | 38225          |
| 3                | 1/2 | 2.870  | 3     | 32230         | 38230          |
| 4                | 5/8 | 3.834  | 4     | 32240         | 38240          |
| 6                | 3/4 | 5.782  | 6     | 32260         | 38260          |
| 8                | 7/8 | 7.782  | 8     | 32280         | 38280          |
| 10               | 7/8 | 9.732  | 10    | 322100        | 382100         |
| 12               | 1   | 11.732 | 12    | 322120        | 382120         |

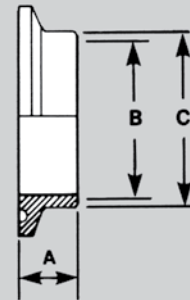

NOTE: 1" CLAMP FITTINGS USE 1-1/2" CLAMPS

### 9MP – Cross Clamp Ends (3-A) 32R<sub>a</sub> ID/32R<sub>a</sub> OD

| SIZE (TUBE O.D.) | A     | B      | 304 STOCK NO. | 316L STOCK NO. |
|------------------|-------|--------|---------------|----------------|
| 1                | 2-3/8 | 4-3/4  | 3210110       | 3810110        |
| 1-1/2            | 2-3/4 | 5-1/2  | 3210115       | 3810115        |
| 2                | 3-1/2 | 7      | 3210120       | 3810120        |
| 2-1/2            | 3-1/2 | 7      | 3210125       | 3810125        |
| 3                | 3-3/4 | 7-1/2  | 3210130       | 3810130        |
| 4                | 4-1/2 | 9      | 3210140       | 3810140        |
| 6                | 5-3/4 | 11-1/2 | 3210160       | 3810160        |
| 8                | 7-7/8 | 15-3/4 | 3210180       | 3810180        |
| 10               | 9-3/8 | 18-3/4 | 32101100      | 38101100       |
| 12               | 11    | 22     | 32101120      | 38101120       |

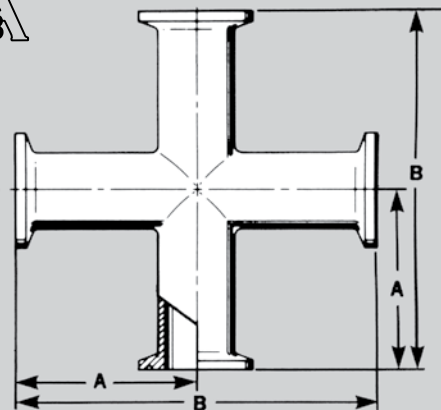

## 23BMP – Thermometer Cap x Clamp End 32R<sub>a</sub> ID/32R<sub>a</sub> OD

| SIZE<br>(TUBE O.D.) | A     | FNPT | 304<br>STOCK NO. | 316L<br>STOCK NO. |
|---------------------|-------|------|------------------|-------------------|
| 3/4                 | 0.984 | 1/4  |                  | 389807A           |
| 1 & 1-1/2           | 1.984 | 1/4  | 32981514         | 38981514          |
| 1 & 1-1/2           | 1.984 | 3/8  | 32981538         | 38981538          |
| 1 & 1-1/2           | 1.984 | 1/2  | 329810B          | 389810B           |
| 1 & 1-1/2           | 1.984 | 3/4  | 329815B          | 389815B           |
| 2                   | 2.516 | 3/4  | 329820B          | 389820B           |
| 2-1/2               | 3.047 | 3/4  | 329825B          | 389825B           |
| 2-1/2               | 3.047 | 1    | 329825C          | 389825C           |
| 3                   | 3.579 | 3/4  | 329830B          | 389830B           |
| 4                   | 4.682 | 3/4  | 329840B          | 389840B           |

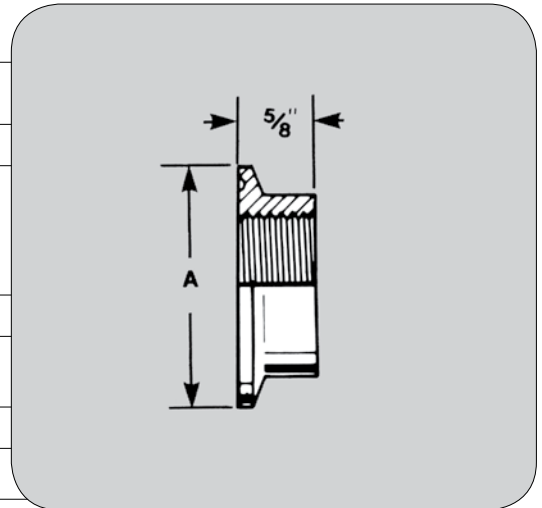

## 31-14MP & 32-14MP – Reducer Concentric & Eccentric Clamp Ends (3-A) 32R<sub>a</sub> ID/32R<sub>a</sub> OD

| SIZE<br>(TUBE O.D.) | A      | 31-14MP CONCENTRIC |                   | 32-14MP ECCENTRIC |                   |
|---------------------|--------|--------------------|-------------------|-------------------|-------------------|
|                     |        | 304<br>STOCK NO.   | 316L<br>STOCK NO. | 304<br>STOCK NO.  | 316L<br>STOCK NO. |
| 3/4 X 1/2           | 2      | -                  | 3884-0705-7       | -                 | 3885-0705-7       |
| 1 X 1/2             | 2-1/2  | -                  | 3884-1005-7       | -                 | 3885-1005-7       |
| 1 X 3/4             | 2      | -                  | 3884-1007-7       | -                 | 3885-1007-7       |
| 1-1/2 X 1/2         | 3-1/2  | -                  | 3884-1505-7       | -                 | 3885-1505-7       |
| 1-1/2 X 3/4         | 3      | -                  | 3884-1507-7       | -                 | 3885-1507-7       |
| 1-1/2 X 1           | 3      | 328415             | 388415-7          | 328515            | 388515-7          |
| 2 X 1/2             | 5-1/2  | -                  | 3884-2005-7       | -                 | 3885-2005-7       |
| 2 X 3/4             | 3      | -                  | 3884-2007-7       | -                 | 3885-2007-7       |
| 2 X 1               | 5      | 328420             | 388420-7          | 328520            | 388520-7          |
| 2 X 1-1/2           | 3      | 328420A            | 388420A-7         | 328520A           | 388520A-7         |
| 2-1/2 X 1           | 7      | 328425             | 388425-7          | 328525B           | 388525-7          |
| 2-1/2 X 1-1/2       | 5      | 328425A            | 388425A-7         | 328525            | 388525A-7         |
| 2-1/2 X 2           | 3      | 328425B            | 388425B-7         | 328525A           | 388525B-7         |
| 3 X 1               | 9      | -                  | -                 | -                 | 388530C-7         |
| 3 X 1-1/2           | 7      | 328430             | 388430-7          | 328530            | 388530-7          |
| 3 X 2               | 5      | 328430A            | 388430A-7         | 328530A           | 388530A-7         |
| 3 X 2-1/2           | 3      | 328430B            | 388430B-7         | 328530B           | 388530B-7         |
| 4 X 1-1/2           | 11-1/8 | 32844015-7         | -                 | 32854015          | -                 |
| 4 X 2               | 9-1/8  | 328440             | 388440-7          | 328540            | 388540-7          |
| 4 X 2-1/2           | 7-1/8  | 328440A            | 388440A-7         | 328540A           | 388540A-7         |
| 4 X 3               | 5-1/8  | 328440B            | 388440B-7         | 328540B           | 388540B-7         |
| 6 X 3               | 7-1/4  | 328460             | 388460-7          | 328560-7          | 388560-7          |
| 6 X 4               | 5-3/8  | 328460A            | 388460A-7         | 328560A-7         | 388560A-7         |
| 8 X 3               | 7-3/8  | 328480B-7          | 388480B-7         | 328580-7          | -                 |
| 8 X 4               | 7-1/2  | 328480-7           | 388480-7          | 328580A-7         | -                 |
| 8 X 6               | 7-5/8  | 328480A-7          | 388480A-7         | 328580B-7         | 388580B-7         |
| 10 X 6              | 8-5/8  | 3284100A-7         | 3884100A-7        | -                 | -                 |
| 10 X 8              | 8-3/4  | 3284100-7          | 3884100-7         | -                 | -                 |
| 12 X 8              | 9-7/8  | -                  | -                 | -                 | -                 |
| 12 X 10             | 9-7/8  | -                  | 3884120-7         | -                 | -                 |

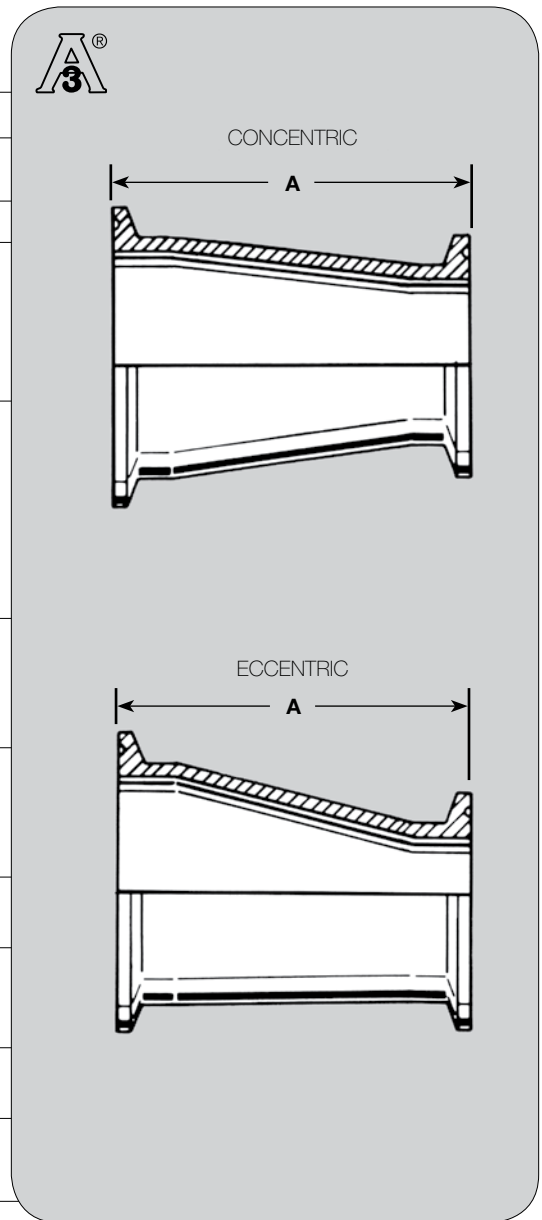

NOTE: 1" CLAMP FITTINGS USE 1-1/2" CLAMPS

21MP – ADAPTER Clamp End x Male NPT 32R<sub>a</sub> ID/32R<sub>a</sub> OD

| SIZE<br>(TUBE O.D.) | A       | 304<br>STOCK NO. | 316L<br>STOCK NO. |
|---------------------|---------|------------------|-------------------|
| 1/2 X 1/8           | 2       | -                | 38820500          |
| 1/2 X 1/4           | 2       | -                | 38820500A         |
| 1/2 X 3/8           | 2       | -                | 38820500B         |
| 1/2 X 1/2           | 2       | -                | 38820505          |
| 1/2 X 3/4           | 2       | -                | 38820507          |
| 3/4 X 1/8           | 2       | -                | 38820700          |
| 3/4 X 1/4           | 2       | -                | 38820700A         |
| 3/4 X 3/8           | 2       | -                | 38820700B         |
| 3/4 X 1/2           | 2       | -                | 38820705          |
| 3/4 X 3/4           | 2       | -                | 38820707          |
| 1 X 1/2             | 2-3/16  | -                | 38821005          |
| 1 X 3/4             | 2-3/16  | 328210           | 38821007          |
| 1 X 1               | 2-1/4   | 328210A          | 38821010          |
| 1 X 1-1/4           | 2-7/16  | 328210D          | -                 |
| 1 X 1-1/2           | 2-7/16  | 328210B          | 38821015          |
| 1 X 2               | 2-5/8   | 328210C          | 38821020          |
| 1-1/2 X 1/2         | 2-3/16  | 32821505         | 38821505          |
| 1-1/2 X 3/4         | 2-3/16  | 328215           | 38821507          |
| 1-1/2 X 1           | 2-5/16  | 328215A          | 38821510          |
| 1-1/2 X 1-1/4       | 2-7/16  | 328215B          | 38821510A         |
| 1-1/2 X 1-1/2       | 2-7/16  | 328215C          | 38821515          |
| 1-1/2 X 2           | 2-5/8   | 328215D          | 38821520          |
| 2 X 1/2             | 2-1/4   | -                | 38822005          |
| 2 X 3/4             | 2-9/32  | -                | 38822007          |
| 2 X 1               | 2-15/32 | 328220D          | 38822010          |
| 2 X 1-1/4           | 2-15/32 | 328220           | 38822010A         |
| 2 X 1-1/2           | 2-15/32 | 328220A          | 38822015          |
| 2 X 2               | 2-21/32 | 328220B          | 38822020          |
| 2 X 2-1/2           | 3-1/8   | 328220C          | 38822025          |
| 2-1/2 X 1           | 2-25/32 | 328225           | -                 |
| 2-1/2 X 1-1/2       | 2-25/32 | 328225A          | 38822515          |
| 2-1/2 X 2           | 2-25/32 | 328225B          | 38822520          |
| 2-1/2 X 2-1/2       | 3-9/32  | 328225C          | 38822525          |
| 3 X 2-1/2           | 3-1/2   | 328230A          | -                 |
| 3 X 3               | 3-1/2   | 328230           | 38823030          |
| 4 X 2               | 3-13/16 | 328240A          | -                 |
| 4 X 3               | 3-13/16 | 328240B          | -                 |
| 4 X 4               | 3-13/16 | 328240           | 38824040          |

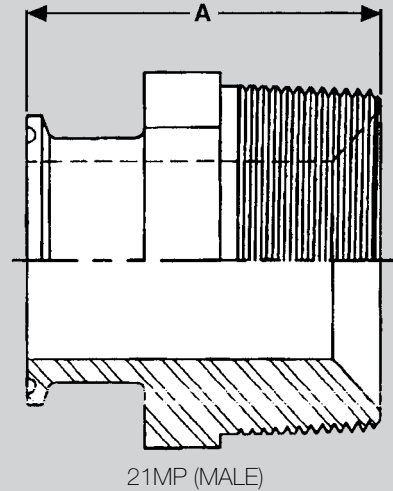

NOTE: WHEN ADAPTER DIMENSIONS ARE GIVEN, SANITARY STYLE END IS ALWAYS INDICATED FIRST  
OTHER SIZES AVAILABLE UPON REQUEST

## 22MP – ADAPTER Clamp End x Female NPT 32R<sub>a</sub> ID/32R<sub>a</sub> OD

| SIZE<br>(TUBE O.D.) | A       | 304<br>STOCK NO. | 316L<br>STOCK NO. |
|---------------------|---------|------------------|-------------------|
| 1/2 X 1/8           | 1-1/8   | -                | 38830500          |
| 1/2 X 1/4           | 1-1/2   | -                | 38830500A         |
| 1/2 X 3/8           | 1-1/2   | -                | 38830500B         |
| 1/2 X 1/2           | 1-1/2   | -                | 38830505          |
| 1/2 X 3/4           | 1-5/8   | -                | 38830507          |
| 3/4 X 1/8           | 1-1/8   | -                | 38830700          |
| 3/4 X 1/4           | 1-1/2   | -                | 38830700A         |
| 3/4 X 3/8           | 1-1/2   | -                | 38830700B         |
| 3/4 X 1/2           | 1-1/2   | -                | 38830700C         |
| 3/4 X 3/4           | 1-5/8   | -                | 38830707          |
| 1 X 1/2             | 1-5/8   | -                | 38831005          |
| 1 X 3/4             | 1-5/8   | 328310           | 38831007          |
| 1 X 1               | 1-5/8   | 328310A          | 38831010          |
| 1 X 1-1/2           | 2-1/4   | 328310B          | 38831015          |
| 1 X 2               | 2-1/4   | 328310C          | 38831020          |
| 1-1/2 X 1/2         | 1-5/8   | 32831505         | 38831505          |
| 1-1/2 X 3/4         | 1-5/8   | 328315           | 38831507          |
| 1-1/2 X 1           | 1-5/8   | 328315A          | 38831510          |
| 1-1/2 X 1-1/4       | 2-1/4   | 328315B          | 38831510A         |
| 1-1/2 X 1-1/2       | 2-1/4   | 328315C          | 38831515          |
| 1-1/2 X 2           | 2-1/4   | 328315D          | 38831520          |
| 2 X 1/2             | 1-11/16 | 32832005         | 38832005          |
| 2 X 1               | 1-11/16 | 32832010         | 38832010          |
| 2 X 1-1/4           | 1-11/16 | 328320           | 38832010A         |
| 2 X 1-1/2           | 1-11/16 | 328320A          | 38832015          |
| 2 X 2               | 2-11/32 | 328320B          | 38832020          |
| 2 X 2-1/2           | 2-13/32 | 328320C          | 38832025          |
| 2-1/2 X 1           | 1-5/16  | 328325           | -                 |
| 2-1/2 X 1-1/2       | 1-21/32 | 328325A          | 38832515          |
| 2-1/2 X 2           | 1-23/32 | 328325B          | 38832520          |
| 2-1/2 X 2-1/2       | 1-23/32 | 328325C          | 38832525          |
| 3 X 3               | 2-3/16  | 328330           | 38833030          |
| 4 X 3               | 2-3/16  | 328340B          | -                 |
| 4 X 4               | 2-5/8   | 328340           | 38834040          |

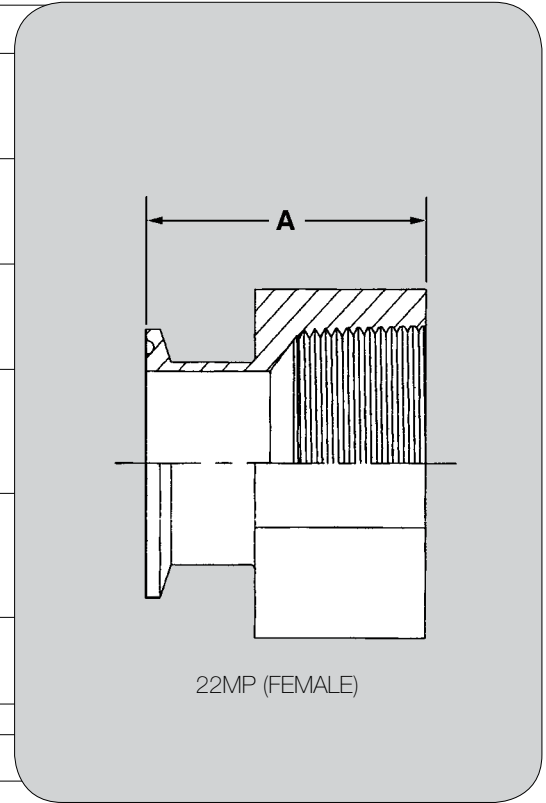

NOTE: WHEN ADAPTER DIMENSIONS ARE GIVEN, SANITARY STYLE END IS ALWAYS INDICATED FIRST  
OTHER SIZES AVAILABLE UPON REQUEST

## 14MPHR – Adapter Clamp End x Rubber Hose Barb 32R<sub>a</sub> ID

| SIZE<br>CLAMP | SIZE<br>BARB | OAL<br>A | BARB OD<br>B | BARB ID<br>C | 304<br>STOCK NO. | 316L<br>STOCK NO. |
|---------------|--------------|----------|--------------|--------------|------------------|-------------------|
| 1/2           | 1/8          | 1.50     | 0.147        | 0.062        | -                | 387800            |
|               | 1/4          |          | 0.312        | 0.187        | -                | 387800A           |
|               | 3/8          |          | 0.405        | 0.218        | -                | 387800B           |
|               | 1/2          |          | 0.540        | 0.375        | -                | 3878005           |
|               | 5/8          |          | 0.625        | 0.437        | -                | -                 |
|               | 3/4          |          | 0.840        | 0.625        | -                | 387805A           |
| 3/4           | 1/8          | 1.50     | 0.147        | 0.062        | -                | 3878007           |
|               | 1/4          |          | 0.312        | 0.187        | -                | 3878007A          |
|               | 3/8          |          | 0.405        | 0.218        | -                | 3878007B          |
|               | 1/2          |          | 0.540        | 0.375        | -                | 3878007C          |
|               | 5/8          |          | 0.625        | 0.437        | -                | -                 |
|               | 3/4          |          | 0.840        | 0.625        | -                | 387807            |
| 1             | 1/4          | 1.50     | 0.312        | 0.187        | -                | -                 |
|               | 3/8          |          | 0.405        | 0.218        | -                | 387810B           |
|               | 1/2          |          | 0.540        | 0.375        | -                | 387810D           |
|               | 5/8          |          | 0.625        | 0.437        | -                | -                 |
|               | 3/4          |          | 0.840        | 0.625        | -                | 387810C           |
|               | 1            | 1.69     | 1.000        | 0.813        | 327810           | 387810            |
| 1-1/2         | 1/4          | 1.50     | 0.312        | 0.187        | -                | 387815D           |
|               | 3/8          |          | 0.405        | 0.218        | -                | 387815C           |
|               | 1/2          |          | 0.540        | 0.375        | -                | 387815A           |
|               | 5/8          |          | 0.625        | 0.437        | -                | 387815E           |
|               | 3/4          |          | 0.840        | 0.625        | -                | 387815B           |
|               | 1            |          | 1.000        | 0.813        | -                | -                 |
|               | 1-1/2        | 1.69     | 1.500        | 1.313        | 327815           | 387815            |
| 2             | 1/2          | 1.75     | 0.540        | 0.375        | -                | 387820B           |
|               | 5/8          | 1.81     | 0.625        | 0.437        | -                | -                 |
|               | 3/4          | 1.81     | 0.840        | 0.625        | -                | 387820A           |
|               | 1            | 2.31     | 1.000        | 0.813        | -                | -                 |
|               | 1-1/2        | 2.31     | 1.500        | 1.313        | -                | -                 |
|               | 2            | 2.31     | 2.000        | 1.813        | 327820           | 387820            |
| 2-1/2         | 3/4          | 2.31     | 0.840        | 0.625        | -                | -                 |
|               | 1            | 2.31     | 1.000        | 0.813        | -                | -                 |
|               | 1-1/2        | 2.31     | 1.500        | 1.313        | -                | -                 |
|               | 2            | 2.31     | 2.000        | 1.813        | -                | -                 |
|               | 2-1/2        | 2.34     | 2.500        | 2.313        | 327825           | 387825            |
| 3             | 1            | 2.34     | 1.000        | 0.813        | -                | -                 |
|               | 1-1/2        | 2.34     | 1.500        | 1.313        | -                | -                 |
|               | 2            | 3.09     | 2.000        | 1.813        | -                | -                 |
|               | 2-1/2        | 3.09     | 2.500        | 2.313        | -                | -                 |
|               | 3            | 3.09     | 3.000        | 2.844        | 327830           | 387830            |
| 4             | 1-1/2        | 3.09     | 1.500        | 1.313        | -                | -                 |
|               | 2            | 3.09     | 2.000        | 1.813        | -                | -                 |
|               | 2-1/2        | 3.41     | 2.500        | 2.313        | -                | -                 |
|               | 3            | 3.41     | 3.000        | 2.844        | -                | -                 |
|               | 4            | 3.41     | 4.000        | 3.844        | 327840           | 387840            |

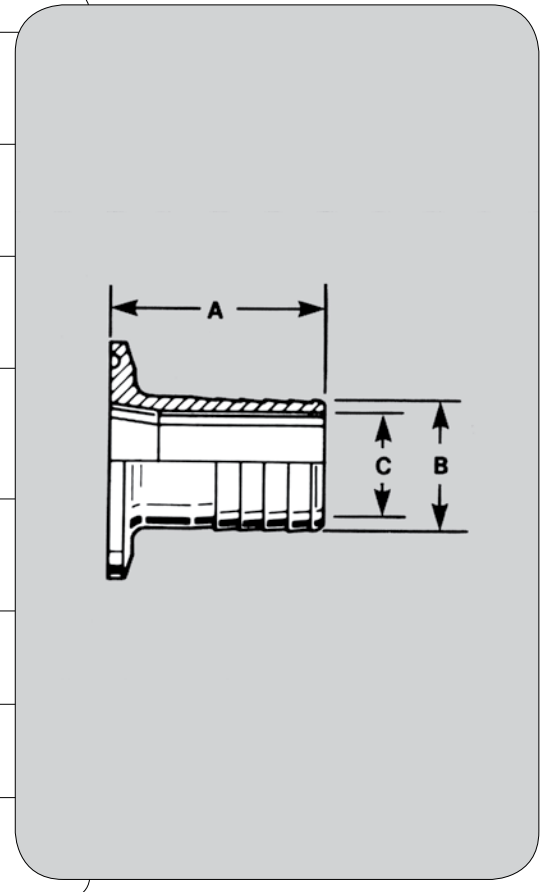

OTHER SIZES AVAILABLE UPON REQUEST

## Adapter & Cap

### 14MPHT – Adapter Clamp End x Long Tube End for Tygon Hose 32R<sub>a</sub> ID/32R<sub>a</sub> OD

| SIZE (TUBE O.D.) | A     | B       | C     | 304 STOCK NO. | 316L STOCK NO. |
|------------------|-------|---------|-------|---------------|----------------|
| 1                | 4-1/2 | 7/8     | 1     | 327910        | 387910         |
| 1-1/2            | 4-1/2 | 1-3/8   | 1-1/2 | 327915        | 387915         |
| 2                | 4-1/2 | 1-7/8   | 2     | 327920        | 387920         |
| 2-1/2            | 4-1/2 | 2-3/8   | 2-1/2 | 327925        | 387925         |
| 3                | 4-1/2 | 2-7/8   | 3     | 327930        | 387930         |
| 4                | 4-5/8 | 3-27/32 | 4     | 327940        | 387940         |

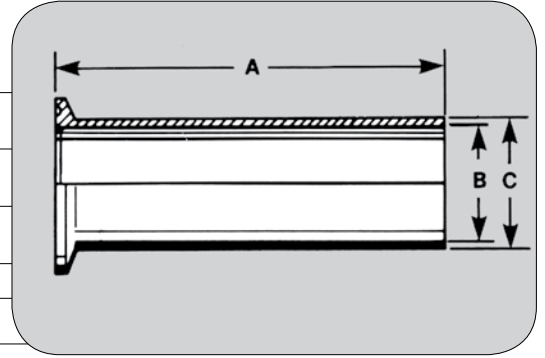

### 17MP-14 – Adapter Clamp End x Bevel Seat Plain End with Hex Nut (3-A) 32R<sub>a</sub> ID/32R<sub>a</sub> OD

| SIZE (TUBE O.D.) | A     | 304 STOCK NO. | 316L STOCK NO. |
|------------------|-------|---------------|----------------|
| 1                | 3     | 328010        | 388010         |
| 1-1/2            | 3     | 328015        | 388015         |
| 2                | 3     | 328020        | 388020         |
| 2-1/2            | 3-1/2 | 328025        | 388025         |
| 3                | 3-3/4 | 328030        | 388030         |
| 4                | 4     | 328040        | 388040         |

HEX NUT INCLUDED

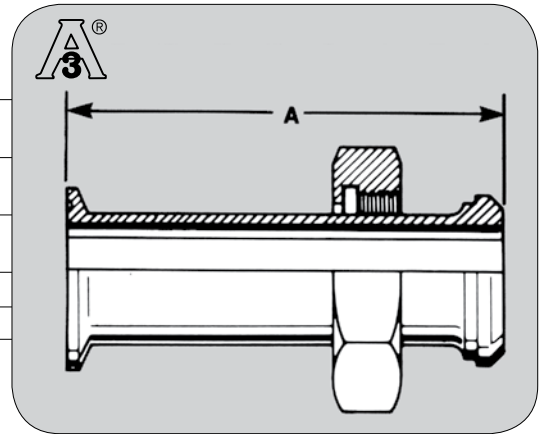

### 17MP-15 – Adapter Clamp End x Bevel Seat Threaded End (3-A) 32R<sub>a</sub> ID/32R<sub>a</sub> OD

| SIZE (TUBE O.D.) | A       | 304 STOCK NO. | 316L STOCK NO. |
|------------------|---------|---------------|----------------|
| 1                | 1-11/16 | 328110        | 388110         |
| 1-1/2            | 1-23/32 | 328115        | 388115         |
| 2                | 1-23/32 | 328120        | 388120         |
| 2-1/2            | 1-27/32 | 328125        | 388125         |
| 3                | 1-29/32 | 328130        | 388130         |
| 4                | 2-11/32 | 328140        | 388140         |

NOTE: 1" CLAMP FITTINGS USE 1-1/2" CLAMPS

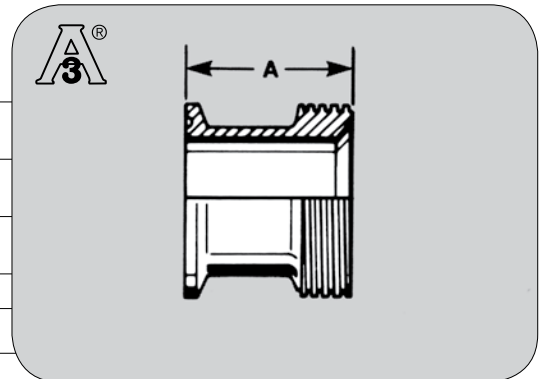

### 16AMP – Cap Solid End Type Clamp (3-A) 32R<sub>a</sub> ID/32R<sub>a</sub> OD

| SIZE (TUBE O.D.) | A    | 304 STOCK NO. | 316L STOCK NO. |
|------------------|------|---------------|----------------|
| 1/2 & 3/4        | .187 | -             | 389807         |
| 1 & 1-1/2        | .250 | 329815        | 389815         |
| 2                | .250 | 329820        | 389820         |
| 2-1/2            | .250 | 329825        | 389825         |
| 3                | .250 | 329830        | 389830         |
| 4                | .312 | 329840        | 389840         |
| 6                | .437 | 329860        | 389860         |
| 8                | .500 | 329880        | 389880         |
| 10               | .500 | 3298100       | 3898100        |
| 12               | .437 | 3298120       | 3898120        |

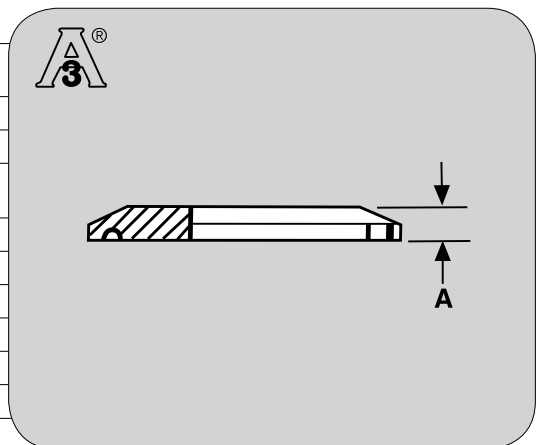



## 2WUMP – U-Bend 180° Clamp End (3-A) 32R<sub>a</sub> ID/32R<sub>a</sub> OD

| SIZE<br>(TUBE O.D.) | A     | B     | 304<br>STOCK NO. | 316L<br>STOCK NO. |
|---------------------|-------|-------|------------------|-------------------|
| 1                   | 3     | 2-1/2 | 32910-7          | 38910-7           |
| 1-1/2               | 4-1/2 | 3-1/2 | 32915-7          | 38915-7           |
| 2                   | 6     | 4-1/2 | 32920-7          | 38920-7           |
| 2-1/2               | 7-1/2 | 5-1/2 | 32925-7          | 38925-7           |
| 3                   | 9     | 6-1/2 | 32930-7          | 38930-7           |
| 4                   | 12    | 8-5/8 | 32940-7          | 38940-7           |

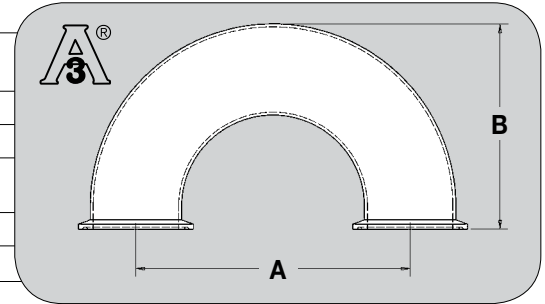

## Line Splitter – Clamp Ends (3-A) 32R<sub>a</sub> ID/32R<sub>a</sub> OD

| SIZE<br>(TUBE O.D.) | A      | B      | R     | 304<br>STOCK NO. | 316L<br>STOCK NO. |
|---------------------|--------|--------|-------|------------------|-------------------|
| 1-1/2               | 3-1/16 | 7-1/2  | 2-1/4 | 32515-7          | 38515-7           |
| 2                   | 3-7/8  | 9      | 3     | 32520-7          | 38520-7           |
| 2-1/2               | 5-7/8  | 11-3/4 | 3-3/4 | 32525-7          | 38525-7           |
| 3                   | 6-1/2  | 13     | 4-1/2 | 32530-7          | 38530-7           |
| 4                   | 8-5/8  | 17-1/4 | 6     | 32540-7          | 38540-7           |

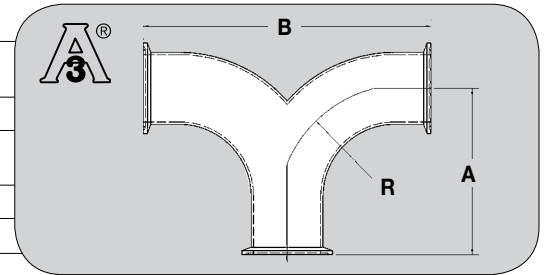

## True "Wye" – Wye True Clamp Ends (3-A) 32R<sub>a</sub> ID/32R<sub>a</sub> OD

| SIZE<br>(TUBE O.D.) | A     | B       | 316L<br>STOCK NO. |
|---------------------|-------|---------|-------------------|
| 1                   | 2-1/2 | 2-7/8   | 381810-7          |
| 1-1/2               | 2-1/2 | 2-15/16 | 381815-7          |
| 2                   | 3-1/8 | 3-3/4   | 381820-7          |
| 2-1/2               | 3-7/8 | 4-5/8   | 381825-7          |
| 3                   | 4-1/2 | 5-3/8   | 381830-7          |
| 4                   | 6     | 7-3/16  | 381840-7          |
| 6                   | 7     | 8-11/16 | 381860-7          |

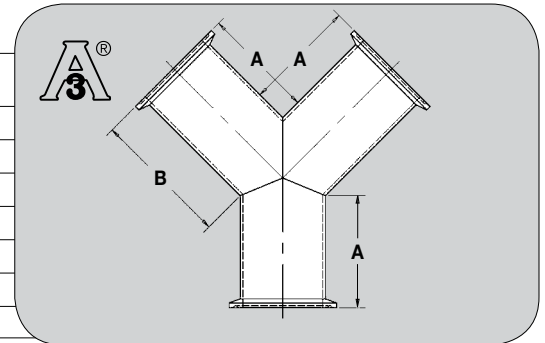

## Lateral "Wye" – Wye Lateral Clamp Ends (3-A) 32R<sub>a</sub> ID/32R<sub>a</sub> OD

| SIZE<br>(TUBE O.D.) | A      | B       | C       | D       | E        | 316L<br>STOCK NO. |
|---------------------|--------|---------|---------|---------|----------|-------------------|
| 1/2                 | 4      | 2-7/32  | 1-3/4   | 2-1/4   | 3-1/8    | 381705-7          |
| 3/4                 | 4      | 2-7/32  | 2 1-3/4 | 2-1/4   | 3-1/8    | 381707-7          |
| 1                   | 5-1/2  | 2-1/4   | 1-3/4   | 2-15/16 | 3-7/16   | 381710-7          |
| 1-1/2               | 5-1/2  | 2-1/4   | 1-3/4   | 3-9/16  | 4-5/16   | 381715-7          |
| 2                   | 6-5/8  | 3-1/8   | 2-3/8   | 4-13/16 | 5-9/16   | 381720-7          |
| 2-1/2               | 7-7/8  | 3-7/8   | 2-7/8   | 5-7/8   | 6-7/8    | 381725-7          |
| 3                   | 9      | 4-1/2   | 3-5/16  | 6-29/32 | 8-3/32   | 381730-7          |
| 4                   | 13-1/4 | 6       | 4-7/16  | 9-5/16  | 10-13/16 | 381740-7          |
| 6                   | 22-1/2 | 11-3/32 | 8       | 15-1/4  | 18-11/32 | 381760-7          |

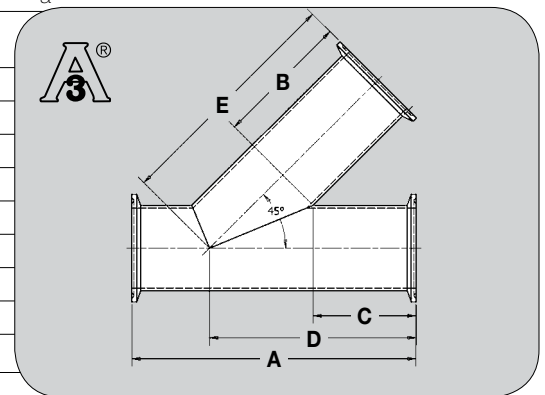

AVAILABLE IN 316L ONLY

## Gasket Clamp Type FDA Compliant



### O-ring

40MP-U BUNA N  
40MP-UW BUNA WHITE  
40RX-PX SILICONE  
40MP-E EPDM  
40MP-G PTFE  
40MP-SFY FKM



### FLANGED (TYPE 2)

40MPF-U BUNA N  
40RX-PX SILICONE  
40MPF-E EPDM  
40MPF-SFY FKM



### ENVELOPE (TYPE 3)

A40MP-GR PTFE

### ALSO AVAILABLE

BEVEL SEAT  
JOHN PERRY

# Clamps

## 13MHM - Clamp Heavy Duty Double Pin Tumble Finish

SIZE RANGE: 1" - 10" TUBE O.D.

| SIZE (TUBE O.D.) | A      | 304 STOCK NO. |
|------------------|--------|---------------|
| 1 & 1-1/2        | 2.140  | 329915        |
| 2                | 2.610  | 329920        |
| 2-1/2            | 3.141  | 329925        |
| 3                | 3.673  | 329930        |
| 4                | 4.776  | 329940        |
| 8                | 8.695  | 329980        |
| 10               | 10.695 | 3299100       |

NOTE: ROCKET STYLE WING NUT AVAILABLE UPON REQUEST - GO TO [topln.co/rocket](http://topln.co/rocket)

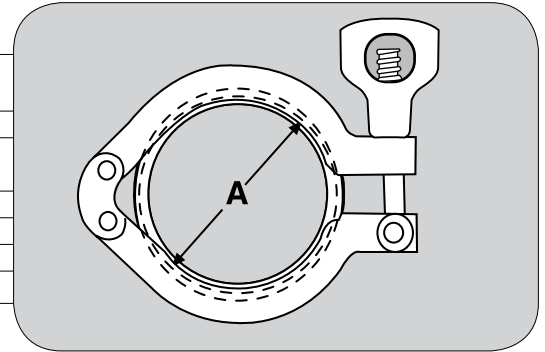

## Clamp Heavy Two Piece Double Wing Nut Tumble Finish

12" TUBE O.D.

| SIZE (TUBE O.D.) | 304 STOCK NO. |
|------------------|---------------|
| 12               | 32992120      |

NOTE: ROCKET STYLE WING NUT AVAILABLE UPON REQUEST - GO TO [topln.co/rocket](http://topln.co/rocket)

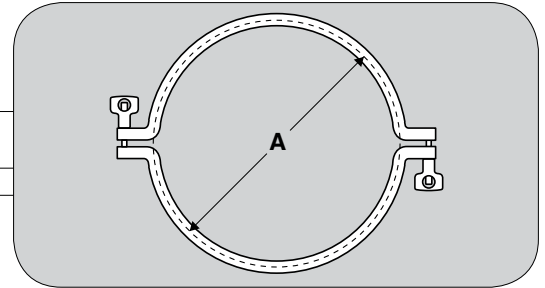

## 13LAH – Clamp Heavy Duty Single Pin Tumble Finish

SIZE RANGE: 1/2" - 8" TUBE O.D.

| SIZE (TUBE O.D.) | A     | 304 STOCK NO. |
|------------------|-------|---------------|
| 1/2 & 3/4        | 1.125 | 389905B       |
| 1 & 1-1/2        | 2.140 | 3299915       |
| 2                | 2.610 | 3299920       |
| 2-1/2            | 3.141 | 3299925       |
| 3                | 3.673 | 3299930       |
| 4                | 4.776 | 3299940       |
| 6                | 6.695 | 3299960       |
| 8                | 8.700 | 3299980       |

NOTE: ROCKET STYLE WING NUT AVAILABLE UPON REQUEST - GO TO [topln.co/rocket](http://topln.co/rocket)

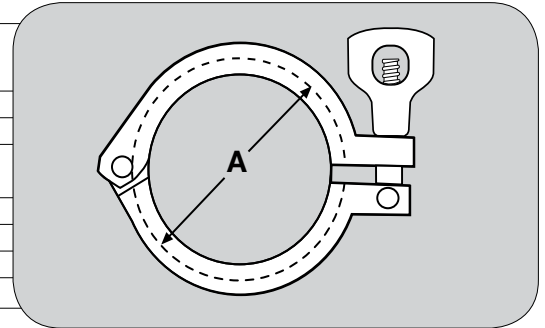

## 13MHP – Clamp High Pressure with Aluminum Bronze Nuts Tumble Finish

SIZE RANGE: 1/2" - 6" TUBE O.D.

| SIZE (TUBE O.D.) | A     | 304 STOCK NO. |
|------------------|-------|---------------|
| 1/2 & 3/4        | 1.125 | 329907HP      |
| 1 & 1-1/2        | 2.046 | 329915HP      |
| 2                | 2.578 | 329920HP      |
| 2-1/2            | 3.110 | 329925HP      |
| 3                | 3.640 | 329930HP      |
| 4                | 4.744 | 329940HP      |
| 6                | 6.632 | 329960HP      |

WITH ALUMINUM BRONZE NUTS

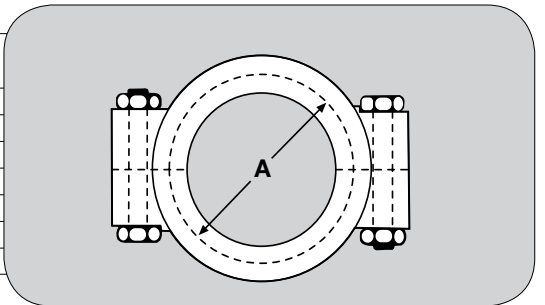

## 13MHHS – Clamp Heavy Duty 3-Segmented Tumble Finish

SIZE RANGE: 1" - 4" TUBE O.D.

| SIZE (TUBE O.D.) | A     | 304 STOCK NO. |
|------------------|-------|---------------|
| 1 & 1-1/2        | 2.140 | 3299153       |
| 2                | 2.610 | 3299203       |
| 2-1/2            | 3.141 | 3299253       |
| 3                | 3.673 | 3299303       |
| 4                | 4.776 | 3299403       |

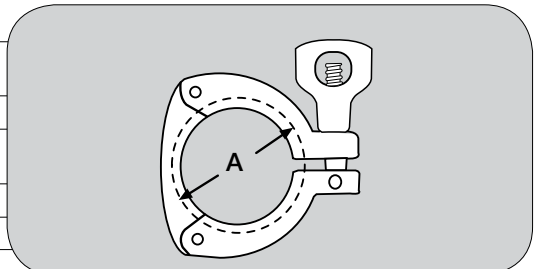

for psi clamp service rating go to [topln.co/clamppsi](http://topln.co/clamppsi)

# Butt Weld Fittings

Top line precision crafted sanitary butt weld polished fittings come standard with the No. 7 ID/OD finish (32R<sub>a</sub> ID/OD) which meets or exceeds FDA and 3-A regulatory standards.

## Specifications:

Size Range: 1" OD - 4" OD, 6" OD

Wall Thickness: .065 (1" - 3")  
 .083 (4")  
 .109 (6")

Materials: 304 (Stock No. prefix 35) as shown in part number matrix  
 316L (Stock No. prefix 39) as shown in part number matrix



## L2S – Elbow 90° Weld Ends (3-A) 32R<sub>a</sub> ID/32R<sub>a</sub> OD

| SIZE (TUBE O.D.) | A       | 304 STOCK NO. | 316L STOCK NO. |
|------------------|---------|---------------|----------------|
| 1                | 2-1/16  | 35710-7       | 39710-7        |
| 1-1/2            | 2-15/16 | 35715-7       | 39715-7        |
| 2                | 4-1/16  | 35720-7       | 39720-7        |
| 2-1/2            | 5-3/16  | 35725-7       | 39725-7        |
| 3                | 6-5/16  | 35730-7       | 39730-7        |
| 4                | 8-5/16  | 35740-7       | 39740-7        |
| 6                | 11-1/2  | 35760-7       | 39760-7        |

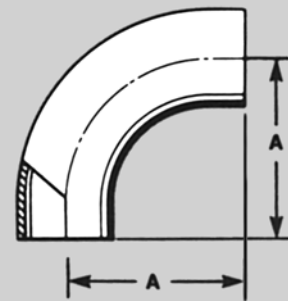

## L2KS – Elbow 45° Weld Ends (3-A) 32R<sub>a</sub> ID/32R<sub>a</sub> OD

| SIZE (TUBE O.D.) | A       | 304 STOCK NO. | 316L STOCK NO. |
|------------------|---------|---------------|----------------|
| 1                | 1-3/16  | 35810-7       | 39810-7        |
| 1-1/2            | 1-5/8   | 35815-7       | 39815-7        |
| 2                | 2-5/16  | 35820-7       | 39820-7        |
| 2-1/2            | 3       | 35825-7       | 39825-7        |
| 3                | 3-11/16 | 35830-7       | 39830-7        |
| 4                | 4-13/16 | 35840-7       | 39840-7        |

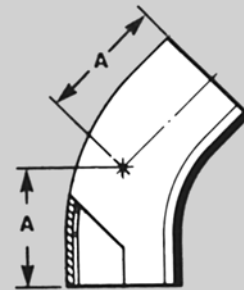

## L2CM – Elbow 90° Weld End x Clamp End (3-A) 32R<sub>a</sub> ID/32R<sub>a</sub> OD

| SIZE (TUBE O.D.) | A       | B       | 304 STOCK NO. | 316L STOCK NO. |
|------------------|---------|---------|---------------|----------------|
| 1                | 2-1/16  | 2-9/16  | 3510510C      | 3910510        |
| 1-1/2            | 2-15/16 | 3-7/16  | 3510515C      | 3910515        |
| 2                | 4-1/16  | 4-9/16  | 3510520C      | 3910520        |
| 2-1/2            | 5-3/16  | 5-11/16 | 3510525C      | 3910525        |
| 3                | 6-5/16  | 6-13/16 | 3510530C      | 3910530        |
| 4                | 8-5/16  | 8-15/16 | 3510540C      | 3910540        |
| 6                | 11-1/2  | 12-1/4  |               | 3910560        |

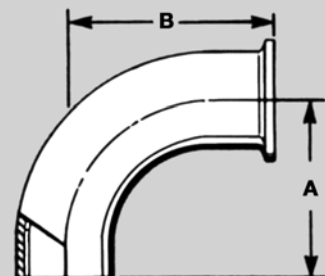

Elbows

L2C – Elbow 90° Bevel Seat Threaded End x Weld End (3-A) 32R<sub>a</sub> ID/32R<sub>a</sub> OD

| SIZE (TUBE O.D.) | A       | B       | 304 STOCK NO. |
|------------------|---------|---------|---------------|
| 1-1/2            | 2-15/16 | 3-21/32 | 3510515T      |
| 2                | 4-1/16  | 4-25/32 | 3510520T      |
| 2-1/2            | 5-3/16  | 6-1/32  | 3510525T      |
| 3                | 6-5/16  | 7-7/32  | 3510530T      |
| 4                | 8-5/16  | 9-17/32 | 3510540T      |

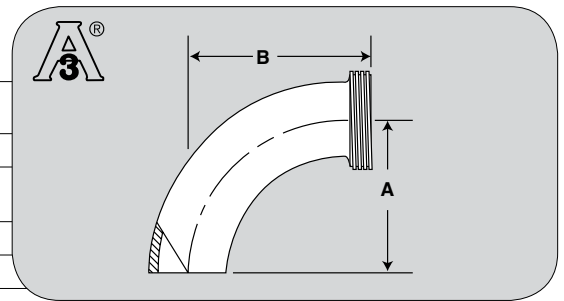

L2F – Elbow 90° Bevel Seat Plain End with Hex Nut x Weld End (3-A) 32R<sub>a</sub> ID/32R<sub>a</sub> OD

| SIZE (TUBE O.D.) | A       | B       | 304 STOCK NO. |
|------------------|---------|---------|---------------|
| 1-1/2            | 2-15/16 | 3-21/32 | 3510615       |
| 2                | 4-1/16  | 4-25/32 | 3510620       |
| 2-1/2            | 5-3/16  | 6-1/32  | 3510625       |
| 3                | 6-5/16  | 7-7/32  | 3510630       |
| 4                | 8-5/16  | 9-17/32 | 3510640       |

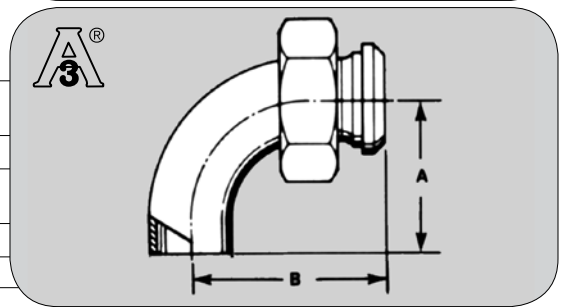

HEX NUT INCLUDED

L2P – Elbow 45° Bevel Seat Plain End with Hex Nut x Weld End (3-A) 32R<sub>a</sub> ID/32R<sub>a</sub> OD

| SIZE (TUBE O.D.) | A       | B       | 304 STOCK NO. |
|------------------|---------|---------|---------------|
| 1-1/2            | 2-11/32 | 1-5/8   | 3510915       |
| 2                | 3-1/32  | 2-5/16  | 3510920       |
| 2-1/2            | 3-27/32 | 3       | 3510925       |
| 3                | 4-19/32 | 3-11/16 | 3510930       |
| 4                | 6-1/32  | 4-13/16 | 3510940       |

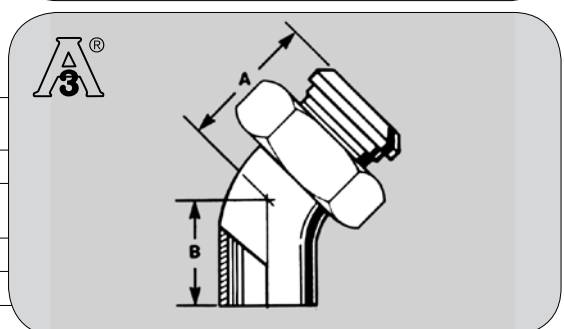

L2K – Elbow 45° Bevel Seat Threaded End x Weld End (3-A) 32R<sub>a</sub> ID/32R<sub>a</sub> OD

| SIZE (TUBE O.D.) | A       | B       | 304 STOCK NO. |
|------------------|---------|---------|---------------|
| 1-1/2            | 2-11/32 | 1-5/8   | 3510815T      |
| 2                | 3-1/32  | 2-5/16  | 3510820T      |
| 2-1/2            | 3-27/32 | 3       | 3510825T      |
| 3                | 4-19/32 | 3-11/16 | 3510830T      |
| 4                | 6-1/32  | 4-13/16 | 3510840T      |

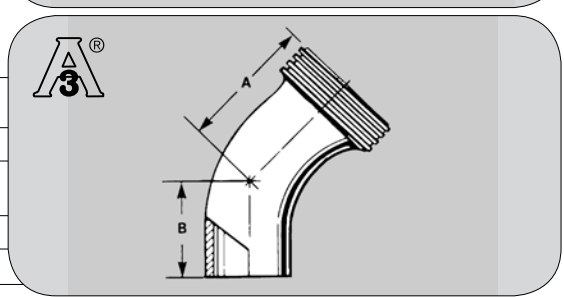

L2KM – Elbow 45° Weld End x Clamp End (3-A) 32R<sub>a</sub> ID/32R<sub>a</sub> OD

| SIZE (TUBE O.D.) | A       | B       | 304 STOCK NO. | 316L STOCK NO. |
|------------------|---------|---------|---------------|----------------|
| 1                | 1-11/16 | 1-3/16  | 3510810C      | 3910810        |
| 1-1/2            | 2-1/8   | 1-5/8   | 3510815C      | 3910815        |
| 2                | 2-13/16 | 2-5/16  | 3510820C      | 3910820        |
| 2-1/2            | 3-1/2   | 3       | 3510825C      | 3910825        |
| 3                | 4-3/16  | 3-11/16 | 3510830C      | 3910830        |
| 4                | 5-7/16  | 4-13/16 | 3510840C      | 3910840        |

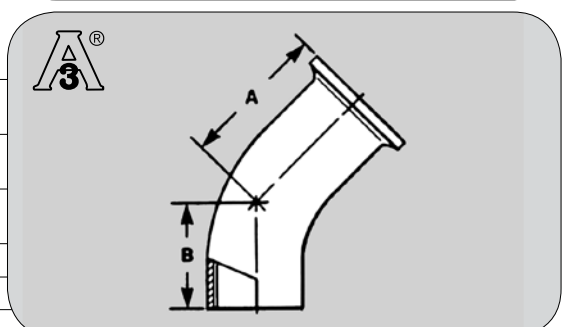

L2CP – Elbow 90° Inspection Type Weld Ends (3-A) 32R<sub>a</sub> ID/32R<sub>a</sub> OD

| SIZE (TUBE O.D.) | A       | B     | 304 STOCK NO. | 316L STOCK NO. |
|------------------|---------|-------|---------------|----------------|
| 1-1/2            | 2-15/16 | 1-3/8 | 3510715       | 3910715        |
| 2                | 4-1/16  | 1-5/8 | 3510720       | 3910720        |
| 2-1/2            | 5-3/16  | 1-7/8 | 3510725       | 3910725        |
| 3                | 6-3/16  | 2-1/8 | 3510730       | 3910730        |
| 4                | 8-3/16  | 2-3/4 | 3510740       | 3910740        |

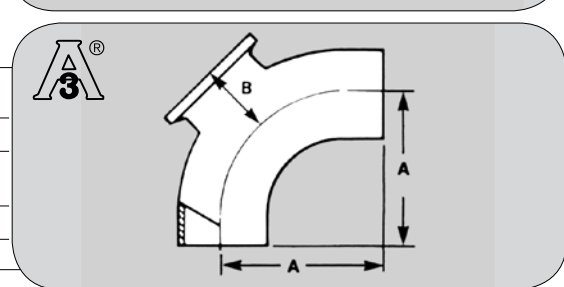

L7WWW – Tee Weld Ends (3-A) 32R<sub>a</sub> ID/32R<sub>a</sub> OD

| SIZE<br>(TUBE O.D.) | A       | B       | 304<br>STOCK NO. | 316L<br>STOCK NO. |
|---------------------|---------|---------|------------------|-------------------|
| 1                   | 1-1/8   | 2-1/4   | 351110-7         | 391110-7          |
| 1-1/2               | 1-21/32 | 3-5/16  | 351115-7         | 391115-7          |
| 2                   | 2-1/16  | 4-1/8   | 351120-7         | 391120-7          |
| 2-1/2               | 2-11/32 | 4-11/16 | 351125-7         | 391125-7          |
| 3                   | 2-19/32 | 5-3/16  | 351130-7         | 391130-7          |
| 4                   | 3-7/16  | 6-7/8   | 351140-7         | 391140-7          |

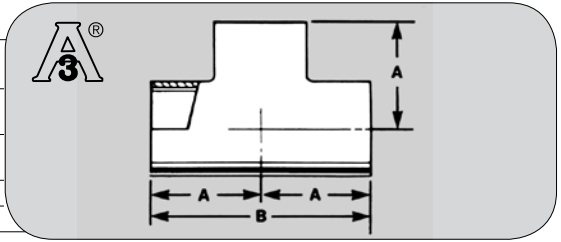

L7RWWW – Tee Reducing Weld Ends (3-A) 32R<sub>a</sub> ID/32R<sub>a</sub> OD

| SIZE<br>(TUBE O.D.) | A       | B       | C       | D     | E     | 304<br>STOCK NO. | 316L<br>STOCK NO. |
|---------------------|---------|---------|---------|-------|-------|------------------|-------------------|
| 1-1/2 X 1           | 3-5/16  | 1-21/32 | 1-3/8   | 1-1/2 | 1     | 351115R10        | 391115R10         |
| 2 X 1               | 4-1/8   | 2-1/16  | 1-5/8   | 2     | 1     | 351120R10        | 391120R10         |
| 2 X 1-1/2           | 4-1/8   | 2-1/16  | 1-29/32 | 2     | 1-1/2 | 351120R15        | 391120R15         |
| 2-1/2 X 1           | 4-11/16 | 2-11/32 | 1-7/8   | 2-1/2 | 1     | 351125R10        | 391125R10         |
| 2-1/2 X 1-1/2       | 4-11/16 | 2-11/32 | 2-5/32  | 2-1/2 | 1-1/2 | 351125R15        | 391125R15         |
| 2-1/2 X 2           | 4-11/16 | 2-11/32 | 2-5/16  | 2-1/2 | 2     | 351125R20        | 391125R20         |
| 3 X 1               | 5-3/16  | 2-19/32 | 2-13/32 | 3     | 1     | 351130R10        | 391130R10         |
| 3 X 1-1/2           | 5-3/16  | 2-19/32 | 2-13/32 | 3     | 1-1/2 | 351130R15        | 391130R15         |
| 3 X 2               | 5-3/16  | 2-19/32 | 2-9/16  | 3     | 2     | 351130R20        | 351130R20         |
| 3 X 2-1/2           | 5-3/16  | 2-19/32 | 2-19/32 | 3     | 2-1/2 | 351130R25        | 391130R25         |
| 4 X 1               | 6-7/8   | 3-7/16  | 2-29/32 | 4     | 1     | 351140R10        | 391140R10         |
| 4 X 1-1/2           | 6-7/8   | 3-7/16  | 2-29/32 | 4     | 1-1/2 | 351140R15        | 391140R15         |
| 4 X 2               | 6-7/8   | 3-7/16  | 3-1/16  | 4     | 2     | 351140R20        | 391140R20         |
| 4 X 2-1/2           | 6-7/8   | 3-7/16  | 3-3/32  | 4     | 2-1/2 | 351140R25        | 391140R25         |
| 4 X 3               | 6-7/8   | 3-7/16  | 3-3/32  | 4     | 3     | 351140R30        | 391140R30         |

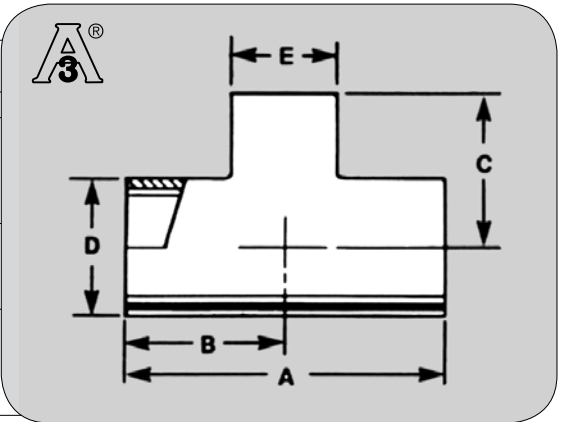

L31 – Reducer Concentric Weld Ends (3-A) 32R<sub>a</sub> ID/32R<sub>a</sub> OD

| SIZE<br>(TUBE O.D.) | A   | 304<br>STOCK NO. | 316L<br>STOCK NO. |
|---------------------|-----|------------------|-------------------|
| 3/4 X 1/2           | 1   | -                | 3911507-7         |
| 1 X 1/2             | 1.5 | -                | 3911510-7         |
| 1 X 3/4             | 1   | -                | 3911510A-7        |
| 1-1/2 X 1/2         | 2.5 | -                | 3911515B-7        |
| 1-1/2 X 3/4         | 2   | -                | 3911515A-7        |
| 1-1/2 X 1           | 2   | 3511515-7        | 3911515-7         |
| 2 X 1/2             | 2.5 | -                | 3911520C-7        |
| 2 X 3/4             | 2   | -                | 3911520B-7        |
| 2 X 1               | 4   | 3511520A-7       | 3911520A-7        |
| 2 X 1-1/2           | 2   | 3511520-7        | 3911520-7         |
| 2-1/2 X 1           | 6   | -                | -                 |
| 2-1/2 X 1-1/2       | 4   | 3511525-7        | 3911525-7         |
| 2-1/2 X 2           | 2   | 3511525A-7       | 3911525A-7        |
| 3 X 1               | 8   | 351153010-7      | -                 |
| 3 X 1-1/2           | 6   | 3511530-7        | 3911530-7         |
| 3 X 2               | 4   | 3511530A-7       | 3911530A-7        |
| 3 X 2-1/2           | 2   | 3511530B-7       | 3911530B-7        |
| 4 X 1-1/2           | 10  | 3511540-7        | 3911540-7         |
| 4 X 2               | 8   | 3511540A-7       | 3911540A-7        |
| 4 X 2-1/2           | 6   | 3511540B-7       | 3911540B-7        |
| 4 X 3               | 4   | 3511540C-7       | 3911540C-7        |

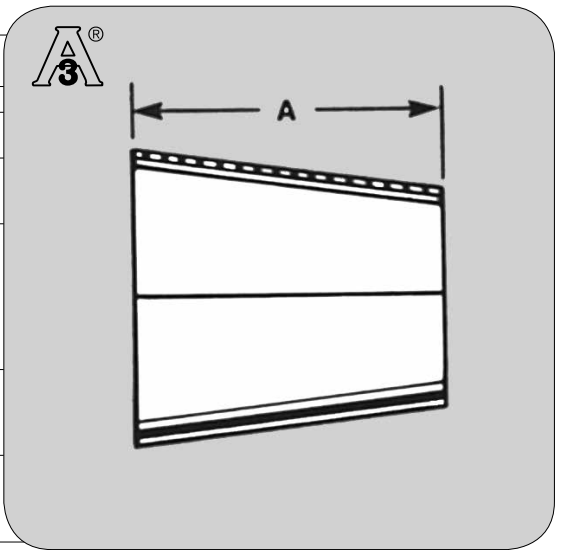

L32 – Reducer Eccentric Weld Ends (3-A) 32R<sub>a</sub> ID/32R<sub>a</sub> OD

| SIZE<br>(TUBE O.D.) | A   | 304<br>STOCK NO. | 316L<br>STOCK NO. |
|---------------------|-----|------------------|-------------------|
| 3/4 X 1/2           | 1   | -                | 391210705-7       |
| 1 X 1/2             | 1.5 | -                | 391211005-7       |
| 1 X 3/4             | 1   | -                | 391211007-7       |
| 1-1/2 X 1/2         | 2.5 | -                | 391211505-7       |
| 1-1/2 X 3/4         | 2   | -                | 391211507-7       |
| 1-1/2 X 1           | 2   | 3512115-7        | 391211510-7       |
| 2 X 1/2             | 2.5 | -                | 391212005-7       |
| 2 X 3/4             | 2   | -                | 391212007-7       |
| 2 X 1               | 4   | 351212010-7      | 391212010-7       |
| 2 X 1-1/2           | 2   | 3512120-7        | 391212015-7       |
| 2-1/2 X 1-1/2       | 4   | 3512125-7        | 391212515-7       |
| 2-1/2 X 2           | 2   | 3512125A-7       | 391212520-7       |
| 3 X 1-1/2           | 6   | 3512130-7        | 391213015-7       |
| 3 X 2               | 4   | 3512130A-7       | 391213020-7       |
| 3 X 2-1/2           | 2   | 3512130B-7       | 391213025-7       |
| 4 X 1-1/2           | 10  | 3512140-7        | 391214015-7       |
| 4 X 2               | 8   | 3512140A-7       | 391214020-7       |
| 4 X 2-1/2           | 6   | 3512140B-7       | 391214025-7       |
| 4 X 3               | 4   | 3512140C-7       | 391214030-7       |

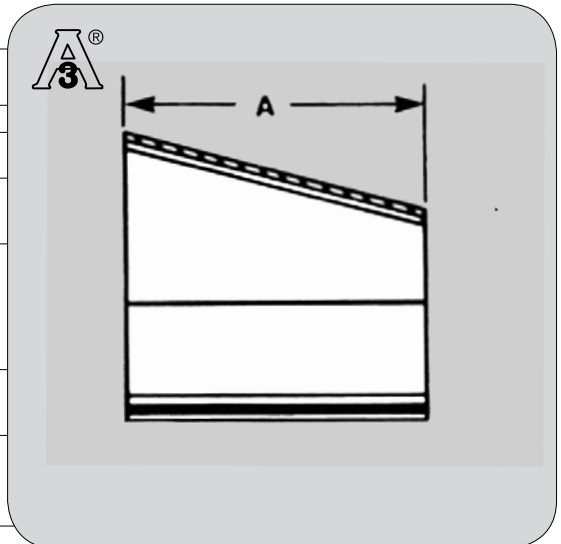

L9WWWW – Cross Weld Ends (3-A) 32R<sub>a</sub> ID/32R<sub>a</sub> OD

| SIZE<br>(TUBE O.D.) | A       | B       | 304<br>STOCK NO. | 316L<br>STOCK NO. |
|---------------------|---------|---------|------------------|-------------------|
| 1                   | 2-1/4   | 1-1/8   | 3511410-7        | 3911410-7         |
| 1-1/2               | 3-5/16  | 1-21/32 | 3511415-7        | 3911415-7         |
| 2                   | 4-1/8   | 2-1/16  | 3511420-7        | 3911420-7         |
| 2-1/2               | 4-11/16 | 2-11/32 | 3511425-7        | 3911425-7         |
| 3                   | 5-3/16  | 2-19/32 | 3511430-7        | 3911430-7         |
| 4                   | 6-7/8   | 3-7/16  | 3511440-7        | 3911440-7         |

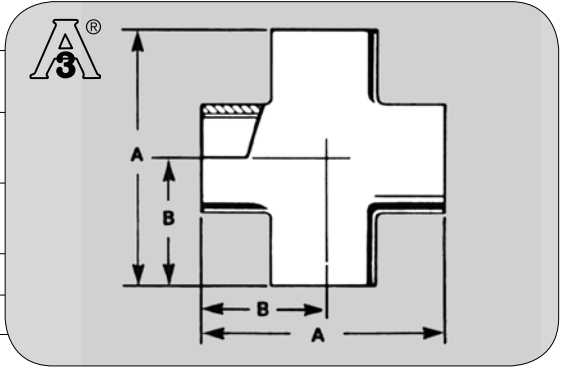

Line Splitter – Weld (3-A) 32R<sub>a</sub> ID/32R<sub>a</sub> OD

| SIZE<br>(TUBE O.D.) | A      | B      | R     | 304<br>STOCK NO. | 316L<br>STOCK NO. |
|---------------------|--------|--------|-------|------------------|-------------------|
| 1-1/2               | 2-9/16 | 6-1/2  | 2-1/4 | 35515-7          | 39515-7           |
| 2                   | 3-3/8  | 8      | 3     | 35520-7          | 39520-7           |
| 2-1/2               | 5-3/8  | 10-3/4 | 3-3/4 | 35525-7          | 39525-7           |
| 3                   | 6      | 12     | 4-1/2 | 35530-7          | 39530-7           |
| 4                   | 8      | 16     | 6     | 35540-7          | 39540-7           |

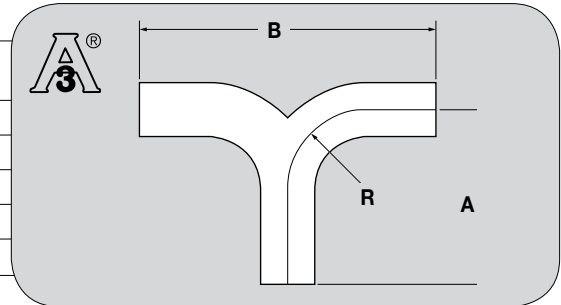

2WUL – U-Bend 180° Weld Ends (3-A) 32R<sub>a</sub> ID/32R<sub>a</sub> OD

| SIZE<br>(TUBE O.D.) | A     | B    | 304<br>STOCK NO. | 316L<br>STOCK NO. |
|---------------------|-------|------|------------------|-------------------|
| 1                   | 3     | 1.5  | 35910-7          | 39910-7           |
| 1-1/2               | 4-1/2 | 2.25 | 35915-7          | 39915-7           |
| 2                   | 6     | 3.0  | 35920-7          | 39920-7           |
| 2-1/2               | 7-1/2 | 3.75 | 35925-7          | 39925-7           |
| 3                   | 9     | 4.5  | 35930-7          | 39930-7           |
| 4                   | 12    | 6    | 35940-7          | 39940-7           |

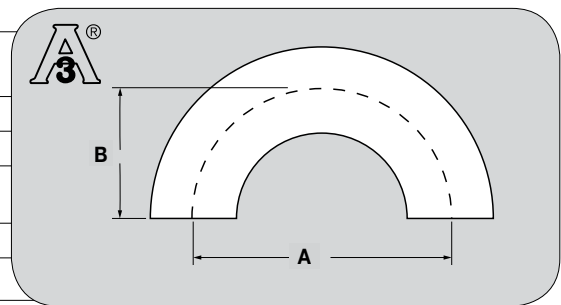

True "Wye" – Wye True Weld Ends (3-A) 32R<sub>a</sub> ID/32R<sub>a</sub> OD

| SIZE<br>(TUBE O.D.) | A     | B       | 316L<br>STOCK NO. |
|---------------------|-------|---------|-------------------|
| 1                   | 2     | 2-3/8   | 391810-7          |
| 1-1/2               | 2     | 2-7/16  | 391815-7          |
| 2                   | 2-5/8 | 3-1/4   | 391820-7          |
| 2-1/2               | 3-3/8 | 4-1/8   | 391825-7          |
| 3                   | 4     | 4-7/8   | 391830-7          |
| 4                   | 5-3/8 | 6-9/16  | 391840-7          |
| 6                   | 6-1/4 | 7-15/16 | 391860-7          |

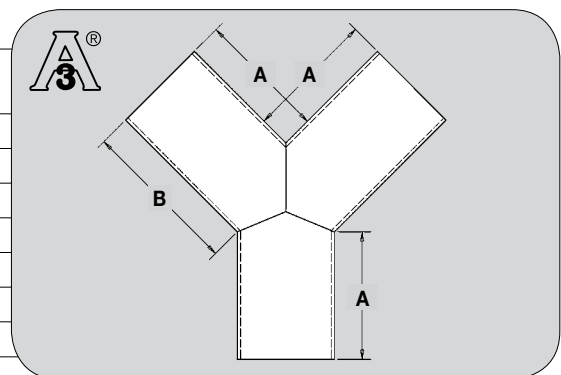

Lateral "Wye" – Wye Lateral Weld Ends (3-A) 32R<sub>a</sub> ID/32R<sub>a</sub> OD

| SIZE<br>(TUBE O.D.) | A     | B        | C       | D       | E        | 316L<br>STOCK NO. |
|---------------------|-------|----------|---------|---------|----------|-------------------|
| 1/2                 | 3     | 2-1/64   | 1-9/64  | 1-3/4   | 2-5/8    | 391705-7          |
| 3/4                 | 3     | 1-23/32  | 27/32   | 1-3/4   | 2-5/8    | 391707-7          |
| 1                   | 4-1/2 | 1-3/4    | 1-1/4   | 2-7/16  | 2-15/16  | 391710-7          |
| 1-1/2               | 4-1/2 | 2        | 1-1/4   | 3-1/16  | 3-13/16  | 391715-7          |
| 2                   | 5-5/8 | 2-5/8    | 1-7/8   | 4-5/16  | 5-1/16   | 391720-7          |
| 2-1/2               | 6-7/8 | 3-3/8    | 2-3/8   | 5-3/8   | 6-3/8    | 391725-7          |
| 3                   | 8     | 4        | 2-13/16 | 6-13/32 | 7-19/32  | 391730-7          |
| 4                   | 12    | 5-3/8    | 3-13/16 | 8-11/16 | 10-3/16  | 391740-7          |
| 6                   | 21    | 10-11/32 | 7-1/4   | 14-1/2  | 17-19/32 | 391760-7          |

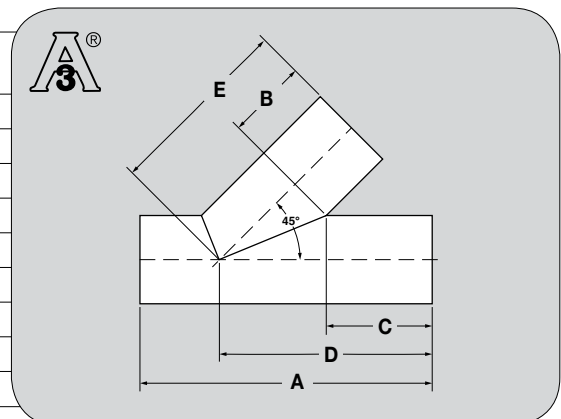



# Tube O.D. Butt Weld Fittings

Top Line precision crafted Tube O.D. butt weld fitting can be upgraded from a standard No. 1 unpolished ID/OD to No. 7 polished ID/OD (32Ra ID/OD) that meet or exceed FDA and 3-A regulatory standards.

## Specifications:

Size Range: 3/4" OD - 12" OD

Wall Thickness: .065 (3/4" - 3")  
 .083 (4")  
 .109 (6" - 8")  
 .109 (10" - 12")  
 .134 (10" - 12")

Materials: 304 (Stock No. prefix 35) as shown in part number matrix  
 316L (Stock No. prefix 39) as shown in part number matrix

Finish: No. 1 - Unpolished (standard)  
 No. 7 - Polished ID and OD (add -7 after 304 or 316L stock number to order)



## 2WCL – Elbow 90° Weld Ends Unpolished

| SIZE (TUBE O.D.) | A     | O.D.  | I.D.   | T    | 304 STOCK NO. | 316L STOCK NO. |
|------------------|-------|-------|--------|------|---------------|----------------|
| 3/4              | 1-1/8 | .75   | .620   | .065 | 3530107V      | –              |
| 1                | 1-1/2 | 1.00  | .870   | .065 | 3530110       | 3930110        |
| 1-1/2            | 2-1/4 | 1.50  | 1.370  | .065 | 3530115       | 3930115        |
| 2                | 3     | 2.00  | 1.870  | .065 | 3530120       | 3930120        |
| 2-1/2            | 3-3/4 | 2.50  | 2.370  | .065 | 3530125       | 3930125        |
| 3                | 4-1/2 | 3.00  | 2.870  | .065 | 3530130       | 3930130        |
| 4                | 6     | 4.00  | 3.834  | .083 | 3530140       | 3930140        |
| 6                | 9     | 6.00  | 5.782  | .109 | 3530160       | 3930160        |
| 8                | 12    | 8.00  | 7.782  | .109 | 3530180       | 3930180        |
| 10               | 15    | 10.00 | 9.782  | .109 | 35301100      | 39301100       |
| 10               | 15    | 10.00 | 9.732  | .134 | 353014100     | 393014100      |
| 12               | 18    | 12.00 | 11.782 | .109 | 35301120      | 39301120       |
| 12               | 18    | 12.00 | 11.732 | .134 | 353014120     | 393014120      |

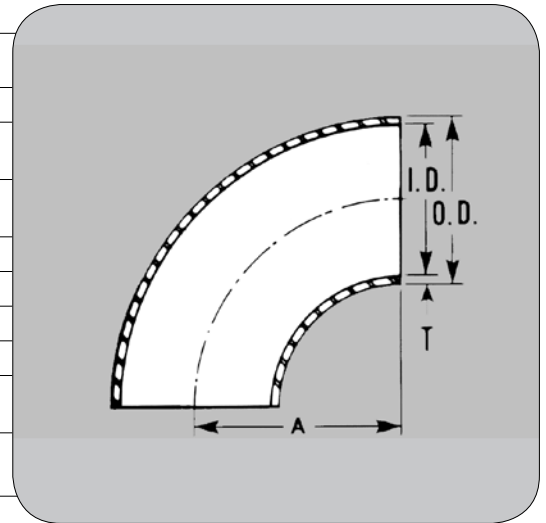

## 2WK – Elbow 45° Weld Ends Unpolished

| SIZE (TUBE O.D.) | A      | O.D. | I.D.   | T    | 304 STOCK NO. | 316L STOCK NO. |
|------------------|--------|------|--------|------|---------------|----------------|
| 1                | 5/8    | 1.0  | .870   | .065 | 3530310       | 3930310        |
| 1-1/2            | 15/16  | 1.5  | 1.370  | .065 | 3530315       | 3930315        |
| 2                | 1-1/4  | 2.0  | 1.870  | .065 | 3530320       | 3930320        |
| 2-1/2            | 1-9/16 | 2.5  | 2.370  | .065 | 3530325       | 3930325        |
| 3                | 1-7/8  | 3.0  | 2.870  | .065 | 3530330       | 3930330        |
| 4                | 2-1/2  | 4.0  | 3.834  | .083 | 3530340       | 3930340        |
| 6                | 3-3/4  | 6.0  | 5.782  | .109 | 3530360       | 3930360        |
| 8                | 5      | 8.0  | 7.782  | .109 | 3530380       | 3930380        |
| 10               | 6-1/4  | 10.0 | 9.782  | .019 | 35303100      | 39303100       |
| 10               | 6-1/4  | 10.0 | 9.732  | .134 | 353034100     | 393034100      |
| 12               | 7-1/2  | 12.0 | 11.782 | .109 | 35303120      | 39303120       |
| 12               | 7-1/2  | 12.0 | 11.732 | .134 | 353034120     | 393034120      |

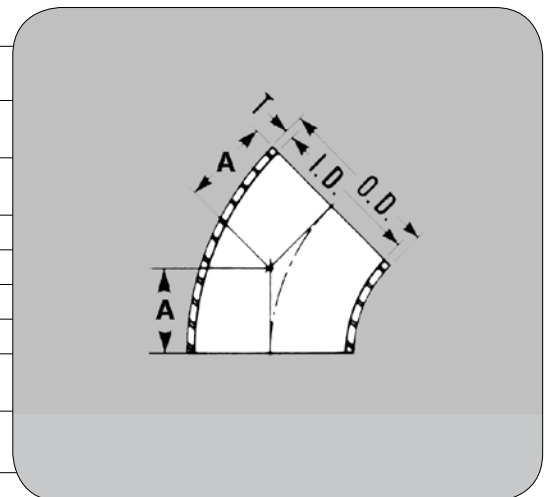

7W – Tee Weld Ends Unpolished

| SIZE<br>(TUBE O.D.) | A     | O.D. | I.D.   | T    | 304<br>STOCK NO. | 316L<br>STOCK NO. |
|---------------------|-------|------|--------|------|------------------|-------------------|
| 1                   | 1-7/8 | 1.0  | .870   | .065 | 3530610          | 3930610           |
| 1-1/2               | 2-1/4 | 1.5  | 1.370  | .065 | 3530615          | 3930615           |
| 2                   | 3     | 2.0  | 1.870  | .065 | 3530620          | 3930620           |
| 2-1/2               | 3     | 2.5  | 2.370  | .065 | 3530625          | 3930625           |
| 3                   | 3-1/4 | 3.0  | 2.870  | .065 | 3530630          | 3930630           |
| 4                   | 3-7/8 | 4.0  | 3.834  | .083 | 3530640          | 3930640           |
| 6                   | 5     | 6.0  | 5.782  | .109 | 3530660          | 3930660           |
| 8                   | 7     | 8.0  | 7.782  | .109 | 3530680          | 3930680           |
| 10                  | 8-1/2 | 10.0 | 9.782  | .109 | 35306100         | 39306100          |
| 10                  | 8-1/2 | 10.0 | 9.732  | .134 | 353064100        | 393064100         |
| 12                  | 10    | 12.0 | 11.782 | .109 | 35306120         | 39306120          |
| 12                  | 10    | 12.0 | 11.732 | .134 | 353064120        | 393064120         |

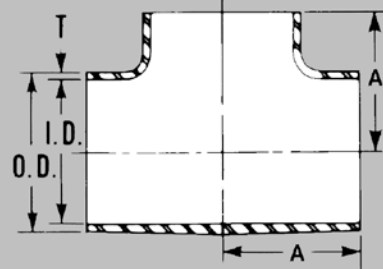

7WR – Tee Reducing Weld Ends Unpolished

| SIZE<br>(TUBE O.D.) | A     | B     | 304<br>STOCK NO. | 316L<br>STOCK NO. |
|---------------------|-------|-------|------------------|-------------------|
| 1-1/2 X 1           | 2-1/4 | 2-1/8 | 3530515R-10      | 3930515R-10       |
| 2 X 1               | 3     | 2-3/8 | 3530520R-10      | 3930520R-10       |
| 2 X 1-1/2           | 3     | 2-1/2 | 3530520R-15      | 3930520R-15       |
| 2-1/2 X 1           | 3     | 2-3/4 | -                | -                 |
| 2-1/2 X 1-1/2       | 3     | 2-3/4 | 3530525R-15      | 3930525R-15       |
| 2-1/2 X 2           | 3     | 3-1/4 | 3530525R-20      | 3930525R-20       |
| 3 X 1               | 3-1/4 | 3     | -                | -                 |
| 3 X 1-1/2           | 3-1/4 | 3     | 3530530R-15      | 3930530R-15       |
| 3 X 2               | 3-1/4 | 3-1/2 | 3530530R-20      | 3930530R-20       |
| 3 X 2-1/2           | 3-1/4 | 3-1/4 | 3530530R-25      | 3930530R-25       |
| 4 X 1               | 3-7/8 | 4     | -                | -                 |
| 4 X 1-1/2           | 3-7/8 | 4     | 3530540R-15      | -                 |
| 4 X 2               | 3-7/8 | 4     | 3530540R-20      | 3930540R-20       |
| 4 X 2-1/2           | 3-7/8 | 3-3/4 | 3530540R-25      | 3930540R-25       |
| 4 X 3               | 3-7/8 | 3-3/4 | 3530540R-30      | 3930540R-30       |
| 6 X 3               | 5     | 5     | 3530560R-30      | 3930560R-30       |
| 6 X 4               | 5     | 5     | 3530560R-40      | 3930560R-40       |
| 8 X 3               | 7     | 7     | -                | -                 |
| 8 X 4               | 7     | 7     | 3530580R-40      | 3930580R-40       |
| 8 X 6               | 7     | 7     | 3530580R-60      | 3930580R-60       |
| 10 X 3              | 8-1/2 | 8-1/2 | -                | -                 |
| 10 X 4              | 8-1/2 | 8-1/2 | -                | -                 |
| 10 X 6              | 8-1/2 | 8-1/2 | -                | -                 |
| 10 X 8              | 8-1/2 | 8-1/2 | -                | -                 |
| 12 X 3              | 10    | 10    | -                | -                 |
| 12 X 4              | 10    | 10    | 35305120R-40     | 39305120R-40      |
| 12 X 6              | 10    | 10    | 35305120R-60     | -                 |
| 12 X 8              | 10    | 10    | -                | -                 |
| 12 X 10             | 10    | 10    | -                | -                 |

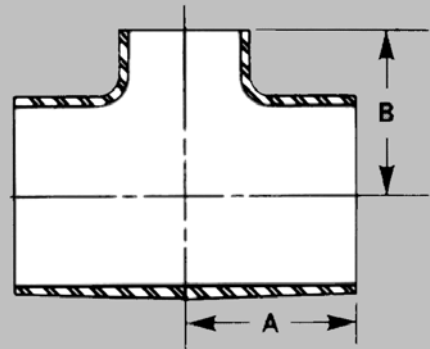

### 31W – Reducer Concentric Weld Ends Unpolished

| SIZE<br>(TUBE O.D.) | A  | 304<br>STOCK NO. | 316L<br>STOCK NO. |
|---------------------|----|------------------|-------------------|
| 1-1/2 X 1           | 2  | 3530815-10       | 3930815-10        |
| 2 X 1               | 4  | 3530820-10       | 3930820-10        |
| 2 X 1-1/2           | 2  | 3530820-15       | 3930820-15        |
| 2-1/2 X 1           | 6  | —                | —                 |
| 2-1/2 X 1-1/2       | 4  | 3530825-15       | 3930825-15        |
| 2-1/2 X 2           | 2  | 3530825-20       | 3930825-20        |
| 3 X 1               | 8  | 3530830-10       | 3930830-10        |
| 3 X 1-1/2           | 6  | 3530830-15       | 3930830-15        |
| 3 X 2               | 4  | 3530830-20       | 3930830-20        |
| 3 X 2-1/2           | 2  | 3530830-25       | 3930830-25        |
| 4 X 1               | 12 | —                | —                 |
| 4 X 1-1/2           | 10 | —                | 3930840-15        |
| 4 X 2               | 8  | 3530840-20       | 3930840-20        |
| 4 X 2-1/2           | 6  | 3530840-25       | 3930840-25        |
| 4 X 3               | 4  | 3530840-30       | 3930840-30        |
| 6 X 3               | 6  | 3530860-30       | 3930860-30        |
| 6 X 4               | 4  | 3530860-40       | 3930860-40        |
| 8 X 3               | 6  | 3530880-30       | 3930880-30        |
| 8 X 4               | 6  | 3530880-40       | 3930880-40        |
| 8 X 6               | 6  | 3530880-60       | 3930880-60        |
| 10 X 6              | 7  | 35308100-60      | 39308100-60       |
| 10 X 8              | 7  | 35308100-80      | 39308100-80       |
| 12 X 8              | 8  | 35308120-80      | 39308120-80       |
| 12 X 10             | 8  | 35308120-100     | 39308120-100      |

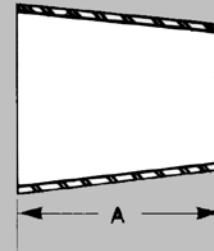

### 32W – Reducer Eccentric Weld Ends Unpolished

| SIZE<br>(TUBE O.D.) | A  | 304<br>STOCK NO. | 316L<br>STOCK NO. |
|---------------------|----|------------------|-------------------|
| 1-1/2 X 1           | 2  | 3530915-10       | 3930915-10        |
| 2 X 1               | 4  | 3530920-10       | 3930920-10        |
| 2 X 1-1/2           | 2  | 3530920-15       | 3930920-15        |
| 2-1/2 X 1           | 6  | —                | —                 |
| 2-1/2 X 1-1/2       | 4  | 3530925-15       | 3930925-15        |
| 2-1/2 X 2           | 2  | 3530925-20       | 3930925-20        |
| 3 X 1               | 8  | —                | —                 |
| 3 X 1-1/2           | 6  | 3530930-15       | 3930930-15        |
| 3 X 2               | 4  | 3530930-20       | 3930930-20        |
| 3 X 2-1/2           | 2  | 3530930-25       | 3930930-25        |
| 4 X 1               | 12 | —                | —                 |
| 4 X 1-1/2           | 10 | —                | —                 |
| 4 X 2               | 8  | 3530940-20       | 3930940-20        |
| 4 X 2-1/2           | 6  | 3530940-25       | 3930940-25        |
| 4 X 3               | 4  | 3530940-30       | 3930940-30        |
| 6 X 3               | 6  | 3530960-30       | 3930960-30        |
| 6 X 4               | 4  | 3530960-40       | 3930960-40        |
| 8 X 3               | 6  | 3530980-30       | 3930980-30        |
| 8 X 4               | 6  | 3530980-40       | 3930980-40        |
| 8 X 6               | 6  | 3530980-60       | 3930980-60        |
| 10 X 6              | 7  | 35309100-60      | 39309100-60       |
| 10 X 8              | 7  | 35309100-80      | 39309100-80       |
| 12 X 8              | 8  | 35309120-80      | 39309120-80       |
| 12 X 10             | 8  | 35309120-100     | 39309120-100      |

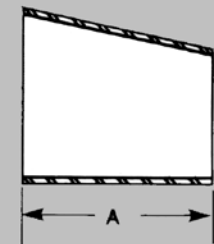

## 38SL – Flange Back Up Machine Finish

| SIZE<br>(TUBE O.D.) | FLANGE THICKNESS |       | I.D.<br>C | B.C.<br>D | NO. & DIA. OF<br>BOLT HOLE<br>E | 304<br>STOCK<br>NO. | 316L<br>STOCK<br>NO. |
|---------------------|------------------|-------|-----------|-----------|---------------------------------|---------------------|----------------------|
|                     | O.D.<br>A        | B     |           |           |                                 |                     |                      |
| 1/2                 | 3.50             | 0.313 | 0.563     | 2.38      | 4 - 5/8                         | 355-05              | 395-05               |
| 3/4                 | 3.79             | 0.344 | 0.813     | 2.75      | 4 - 5/8                         | 355-07              | 395-07               |
| 1                   | 4.25             | 0.375 | 1.063     | 3.13      | 4 - 5/8                         | 355-1               | 395-10               |
| 1-1/2               | 5.00             | 0.375 | 1.563     | 3.88      | 4 - 5/8                         | 355-15              | 395-15               |
| 2                   | 6.00             | 0.438 | 2.063     | 4.75      | 4 - 3/4                         | 355-2               | 395-20               |
| 2-1/2               | 7.00             | 0.438 | 2.563     | 5.50      | 4 - 3/4                         | 355-25              | 395-25               |
| 3                   | 7.50             | 0.500 | 3.063     | 6.00      | 4 - 3/4                         | 355-3               | 395-30               |
| 4                   | 9.00             | 0.500 | 4.063     | 7.50      | 8 - 3/4                         | 355-4               | 395-40               |
| 6                   | 11.00            | 0.563 | 6.063     | 9.50      | 8 - 7/8                         | 355-6               | 395-60               |
| 8                   | 13.50            | 0.563 | 8.060     | 11.75     | 8 - 7/8                         | 355-8               | -                    |
| 10                  | 16.00            | 0.688 | 10.060    | 14.25     | 12 - 1/2                        | -                   | -                    |
| 12                  | 19.00            | 0.688 | 12.060    | 17.00     | 12 - 1/2                        | -                   | -                    |

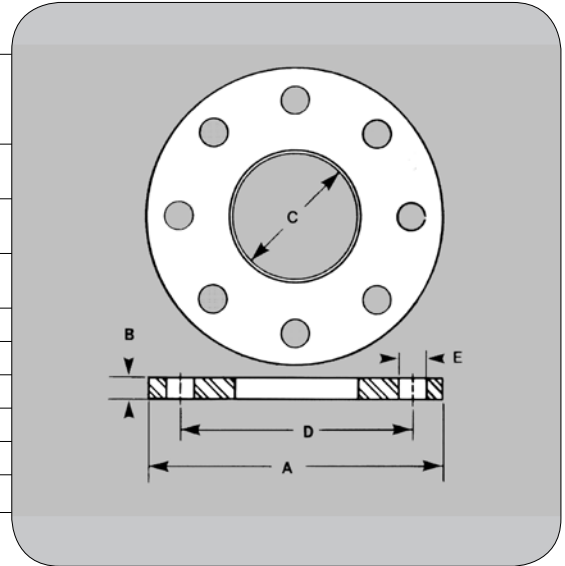

## 9W – Cross Weld Ends Unpolished

| SIZE<br>(TUBE O.D.) | A     | O.D.   | I.D.   | T    | 304<br>STOCK NO. | 316L<br>STOCK NO. |
|---------------------|-------|--------|--------|------|------------------|-------------------|
| 1                   | 1-7/8 | 1.000  | .870   | .065 | 3530410          | 3930410           |
| 1-1/2               | 2-1/4 | 1.500  | 1.370  | .065 | 3530415          | 3930415           |
| 2                   | 3     | 2.000  | 1.870  | .065 | 3530420          | 3930420           |
| 2-1/2               | 3     | 2.500  | 2.370  | .065 | 3530425          | 3930425           |
| 3                   | 3-1/4 | 3.000  | 2.870  | .065 | 3530430          | 3930430           |
| 4                   | 3-7/8 | 4.000  | 3.834  | .083 | 3530440          | 3930440           |
| 6                   | 5     | 6.000  | 5.782  | .109 | 3530460          | 3930460           |
| 8                   | 7     | 8.000  | 7.782  | .109 | 3530480          | 3930480           |
| 10                  | 8-1/2 | 10.000 | 9.782  | .109 | 35304100         | 39304100          |
| 10                  | 8-1/2 | 10.000 | 9.732  | .134 | 353044100        | 393044100         |
| 12                  | 10    | 12.000 | 11.782 | .109 | 35304120         | 39304120          |
| 12                  | 10    | 12.000 | 11.732 | .134 | 353044120        | 393044120         |

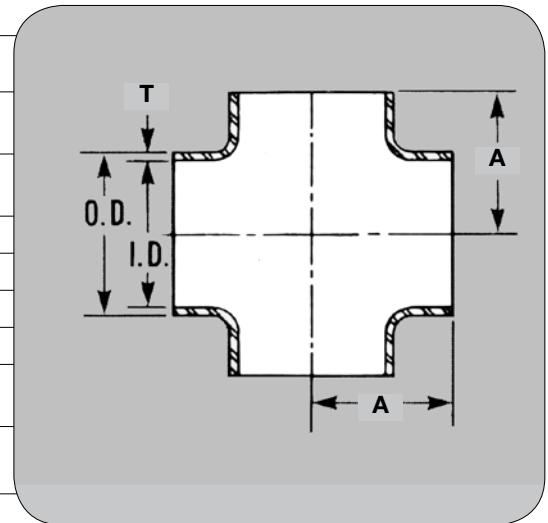

## 16W – Cap Weld End Stamped Unpolished

| SIZE<br>(TUBE O.D.) | A    | O.D.  | I.D.  | T     | 304<br>STOCK NO. | 316L<br>STOCK NO. |
|---------------------|------|-------|-------|-------|------------------|-------------------|
| 1/2                 | 0.25 | 0.50  | 0.370 | 0.065 | -                | 3931605           |
| 3/4                 | 0.31 | 0.75  | 0.620 | 0.065 | -                | 3931607           |
| 1                   | 0.75 | 1.00  | 0.870 | 0.065 | 3531610S         | 3931610S          |
| 1-1/2               | 0.56 | 1.50  | 1.370 | 0.065 | 3531615S         | 3931615S          |
| 2                   | 0.75 | 2.00  | 1.870 | 0.065 | 3531620S         | 3931620S          |
| 2-1/2               | 1.00 | 2.50  | 2.370 | 0.065 | 3531625S         | 3931625S          |
| 3                   | 1.25 | 3.00  | 2.870 | 0.065 | 3531630S         | 3931630S          |
| 4                   | 1.50 | 4.00  | 3.834 | 0.083 | 3531640S         | 3931640S          |
| 6                   | 2.25 | 6.00  | 5.782 | 0.109 | 3531660S         | 3931660S          |
| 8                   | 2.50 | 8.00  | 7.782 | 0.109 | -                | 3931680S          |
| 10                  | 3.00 | 10.00 | 9.732 | 0.134 | -                | 39316100S         |

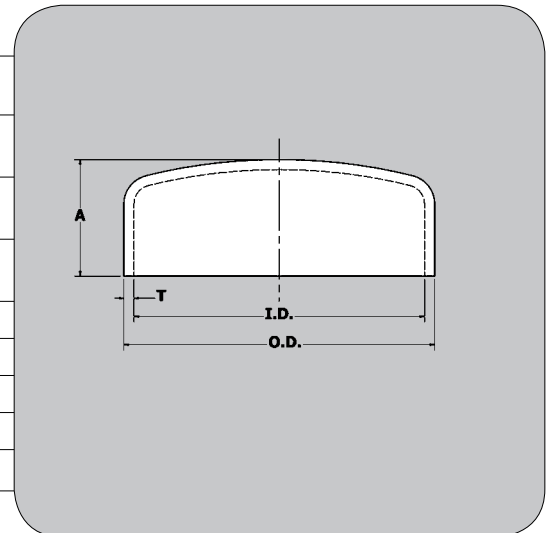

## 19WB – Adapter Weld End x Male NPT 32R<sub>a</sub> ID/32R<sub>a</sub> OD

| SIZE<br>(TUBE O.D.) | A    | O.D. | I.D.  | 304<br>STOCK NO. | 316L<br>STOCK NO. |
|---------------------|------|------|-------|------------------|-------------------|
| 1/2                 | 1.63 | 0.50 | 0.370 | –                | 3931905           |
| 3/4                 | 1.63 | 0.75 | 0.620 | 3531907          | 3931907           |
| 1                   | 1.75 | 1.00 | 0.870 | 3531910          | 3931910           |
| 1-1/2               | 1.75 | 1.50 | 1.370 | 3531915          | 3931915           |
| 2                   | 1.81 | 2.00 | 1.870 | 3531920          | 3931920           |
| 2-1/2               | 2.31 | 2.50 | 2.370 | 3531925          | 3931925           |
| 3                   | 2.50 | 3.00 | 2.870 | 3531930          | 3931930           |
| 4                   | 2.56 | 4.00 | 3.834 | 3531940          | 3931940           |

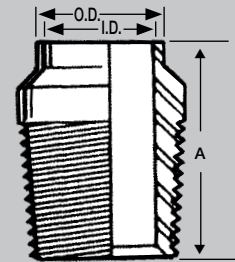

## 22WB – Adapter Weld End x Female NPT 32R<sub>a</sub> ID/32R<sub>a</sub> OD

| SIZE<br>(TUBE O.D.) | A    | O.D. | I.D.  | 304<br>STOCK NO. | 316L<br>STOCK NO. |
|---------------------|------|------|-------|------------------|-------------------|
| 1/2                 | 1.63 | 0.50 | 0.370 | 3532205          | 3932205           |
| 3/4                 | 1.63 | 0.75 | 0.620 | 3532207          | 3932207           |
| 1                   | 1.75 | 1.00 | 0.870 | 3532210          | 3932210           |
| 1-1/2               | 1.75 | 1.50 | 1.370 | 3532215          | 3932215           |
| 2                   | 1.75 | 2.00 | 1.870 | 3532220          | 3932220           |
| 2-1/2               | 2.25 | 2.50 | 2.370 | 3532225          | 3932225           |
| 3                   | 2.50 | 3.00 | 2.870 | 3532230          | 3932230           |
| 4                   | 2.63 | 4.00 | 3.834 | 3532240          | 3932240           |

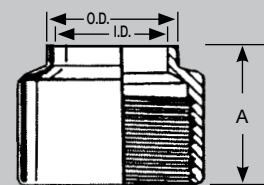

## 14VB – Stub End Lap Joint Unpolished

| SIZE<br>(TUBE O.D.) | A     | O.D.  | I.D.   | B    | T     | C     | 316L<br>STOCK NO. |
|---------------------|-------|-------|--------|------|-------|-------|-------------------|
| 1/2                 | 1.69  | 0.50  | 0.370  | 1.38 | 0.065 | 0.098 | 3930705           |
| 3/4                 | 1.69  | 0.75  | 0.620  | 1.38 | 0.065 | 0.098 | 3930707           |
| 1                   | 2.00  | 1.00  | 0.870  | 1.63 | 0.065 | 0.125 | 3930710           |
| 1-1/2               | 2.88  | 1.50  | 1.370  | 1.75 | 0.065 | 0.125 | 3930715           |
| 2                   | 3.63  | 2.00  | 1.870  | 1.50 | 0.065 | 0.125 | 3930720           |
| 2-1/2               | 4.13  | 2.50  | 2.370  | 2.00 | 0.065 | 0.125 | 3930725           |
| 3                   | 5.00  | 3.00  | 2.870  | 2.25 | 0.065 | 0.125 | 3930730           |
| 4                   | 6.19  | 4.00  | 3.834  | 2.63 | 0.083 | 0.250 | 3930740           |
| 6                   | 8.50  | 6.00  | 5.782  | 3.00 | 0.109 | 0.250 | 3930760           |
| 8                   | 10.63 | 8.00  | 7.782  | 3.00 | 0.109 | –     | 3930780           |
| 10                  | 12.75 | 10.00 | 9.732  | 3.50 | 0.134 | –     | 39307100          |
| 12                  | 15.00 | 12.00 | 11.732 | 3.50 | 0.134 | –     | 39307120          |

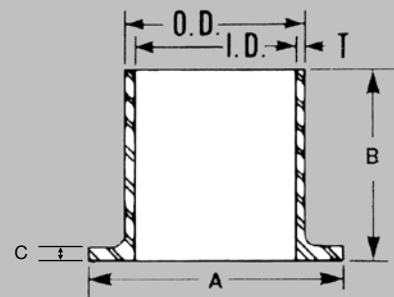

\*Flange Face is Phonographed

# Bevel Seat Fittings

Top Line precision crafted Bevel Seat ACME Thread Union Fittings provide fast, sanitary and secure connections. Polished fittings meet or exceed FDA and 3-A regulatory standards.

[topln.co/bevel](http://topln.co/bevel)



# TI-Line Fitting

Available in 304 SS, sizes 1" - 4". Standard finish 32Ra. Other finishes, material grade, and configurations available upon request.

[topln.co/ti](http://topln.co/ti)



The clamp in this picture is not 3-A.

# John Perry

Available in 304 SS, sizes 1" - 4". Standard finish 32Ra. Other finishes, material grade, and configurations available upon request.

[topln.co/johnperry](http://topln.co/johnperry)

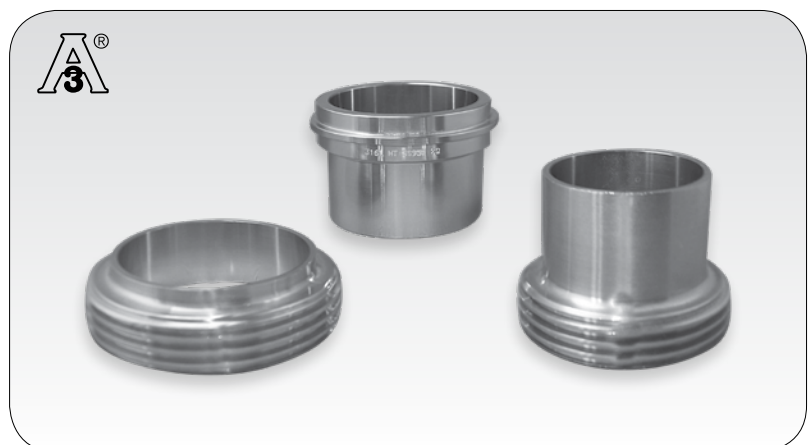



# TOP-FLO® Butterfly Valves

## TOP-FLO® Value

- Ideally suited for the beer and wine industries
- Sizes: 1", 1-1/2", 2", 2-1/2", 3", 4"
- Material: 316L SS
- Seal Material: EPDM
- Connections: clamp only
- 12 position trigger handle
- Manual operation only
- Part numbers listed in short URL

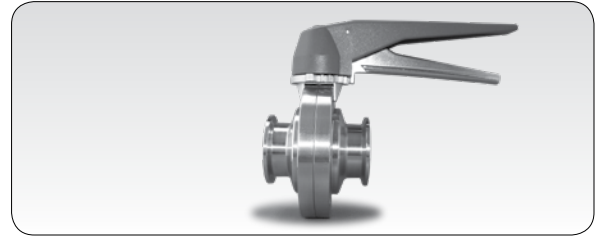

| TOP-FLO® VALUE - Manual Butterfly Valve   |                            |            |       |  |      |                    |                                       |
|---|----------------------------|------------|-------|--|------|--------------------|---------------------------------------|
| Body/Disc Material & End Connections  |                            | Valve Size |       | Seal Material  |      | Manual Handle Type |                                       |
| <b>38301</b>  | 316L MATERIAL - CLAMP ENDS | <b>10</b>  | 1     | <b>EP</b>  | EPDM | <b>M12</b>         | 12-POSITION PLASTIC/SS TRIGGER HANDLE |
| Part Number Example:<br>3830120EPM12<br>316L Material-Clamp Ends, 2", EPDM, 12-Position Plastic/SS Trigger Handle |                            | <b>15</b>  | 1-1/2 | NOTES:<br>AUTOMATION IS NOT AVAILABLE FOR VALUE SERIES BVF |      |                    |                                       |
|   |                            | <b>20</b>  | 2     |  |      |                    |                                       |
|   |                            | <b>25</b>  | 2-1/2 |  |      |                    |                                       |
|   |                            | <b>30</b>  | 3     |  |      |                    |                                       |
|   |                            | <b>40</b>  | 4     |  |      |                    |                                       |

## TOP-FLO® Standard

- Sizes: 1/2", 3/4", 1", 1-1/2", 2", 2-1/2", 3", 4", 6", 8"\*
- Materials: 304 or 316L SS
- Seals available: platinum cured silicone (standard), EPDM or FKM
- Connections: clamp, butt weld and bevel seat (optional) (other connections available upon request)
- Four position spring loaded flat handle
- Optional 13 position SS trigger handle
- Air and electric actuators available
- Variety of controls available
- Part numbers listed in short URL



| TOP-FLO® STANDARD - Manual Butterfly Valve   |                            |            |       |  |              |                    |  |
|--|----------------------------|------------|-------|--|--------------|--------------------|--|
| Body/Disc Material & End Connections   |                            | Valve Size |       | Seal Material  |              | Manual Handle Type |  |
| <b>32201</b>   | 304 MATERIAL - CLAMP ENDS  | <b>05</b>  | 1/2   | <b>S</b>   | P/C Silicone | --                 | 4-POSITION FLAT HANDLE                     |
| <b>35128</b>   | 304 MATERIAL - WELD ENDS   | <b>07</b>  | 3/4   | <b>EP</b>  | EPDM         | <b>M9</b>          | 9-POSITION LOCKABLE TRIGGER HANDLE (304SS) |
| <b>38201</b>   | 316L MATERIAL - CLAMP ENDS | <b>10</b>  | 1     | <b>V</b>   | FKM          | <b>PH4</b>         | 4-POSITION PULL HANDLE W/ KNOB             |
| <b>39128</b>   | 316L MATERIAL - WELD ENDS  | <b>15</b>  | 1-1/2 | NOTES:<br>M9 9-POSITION HANDLES ARE FOR SIZES 1" - 4" ONLY<br>*8" VALVE ONLY AVAILABLE IN CLAMP ENDS / EPDM SEAL / PH4 HANDLE<br>PH4 HANDLE NOT AVAILABLE FOR 6" VALVE |              |                    |  |
| Part Number Example:<br>3820125SM9<br>316L Material-Clamp Ends, 2-1/2", P/C Silicone, 9-Position Lockable Trigger Handle (304SS) |                            | <b>20</b>  | 2     |  |              |                    |  |
|  |                            | <b>25</b>  | 2-1/2 |  |              |                    |  |
|  |                            | <b>30</b>  | 3     |  |              |                    |  |
|  |                            | <b>40</b>  | 4     |  |              |                    |  |
|  |                            | <b>60</b>  | 6     |  |              |                    |  |
| <b>80</b>  | 8                          |            |       |  |              |                    |  |

| TOP-FLO® STANDARD - Automated Butterfly Valve   |   |           |   |       |  |              |                 |   |
|---|---|-----------|---|-------|--|--------------|-----------------|---|
| Body/Disc Material & End Connections  |   | Series    | Valve Size                                    |       | Seal Material  |              | Automation Type |   |
| <b>32</b>   | 304 MATERIAL - CLAMP ENDS                             | <b>S</b>  | <b>10</b>                                     | 1     | <b>S</b>   | P/C Silicone | <b>A1</b>       | TA SERIES DOUBLE ACTING - 80 PSI AIR SUPPLY |
| <b>35</b>   | 304 MATERIAL - WELD ENDS                              |           | <b>15</b>                                     | 1-1/2 | <b>E</b>   | EPDM         | <b>A2</b>       | TA SERIES DOUBLE ACTING - 60 PSI AIR SUPPLY |
| <b>38</b>   | 316L MATERIAL - CLAMP ENDS                            |           | <b>20</b>                                     | 2     | <b>V</b>   | FKM          | <b>S1</b>       | TA SERIES SPRING RETURN - 80 PSI AIR SUPPLY |
| <b>39</b>   | 316L MATERIAL - WELD ENDS                             |           | <b>25</b>                                     | 2-1/2 | NOTES:<br>ACTUATOR OPTION CODES C1 & C2 ARE FOR VALVE SIZES 1" - 4" ONLY |              |                 |   |
| Part Number Example:<br>35S30ES1<br>304 Material-Weld Ends, Series, 3", EPDM, TA Series Spring Return - 80 PSI Air Supply |   | <b>30</b> | 3   |       |  |              |                 |   |
|   |   | <b>40</b> | 4   |       |  |              |                 |   |
|   |   | <b>60</b> | 6   |       |  |              |                 |   |
|   |   | <b>80</b> | 8   |       |  |              |                 |   |
|   |   | <b>E1</b> | WE SERIES - 115VAC - NEMA 4,4X,6 - OPEN/CLOSE |       |  |              |                 |   |
| <b>E2</b>   | WE SERIES - 24VDC - NEMA 4,4X,6 - OPEN/CLOSE          |           |   |       |  |              |                 |   |
| <b>E3</b>   | WE SERIES - 220VAC - NEMA 4,4X,6 - OPEN/CLOSE         |           |   |       |  |              |                 |   |
| <b>C1</b>   | SS CANISTER - S/R - 80 PSI AIR SUPPLY                 |           |   |       |  |              |                 |   |
| <b>C2</b>   | SS CANISTER - D/A - 80 PSI AIR SUPPLY                 |           |   |       |  |              |                 |   |
| <b>EM1</b>  | WEM SERIES - 115VAC - NEMA 4,4X,6 - 4-20mA MODULATING |           |   |       |  |              |                 |   |
| <b>EM2</b>  | WEM SERIES - 24VDC - NEMA 4,4X,6 - 4-20mA MODULATING  |           |   |       |  |              |                 |   |
| <b>EM3</b>  | WEM SERIES - 220VAC - NEMA 4,4X,6 - 4-20mA MODULATING |           |   |       |  |              |                 |   |

## Premium – Definox

- Sizes - 1", 1-1/2", 2", 2-1/2", 3", 4", 6"
- Material: 316L SS
- Seal Material: 1"-2" HNBR, EPDM, or FKM  
2-1/2"-6" Silicone, EPDM, or FKM
- Connections: clamp or butt weld
- Four position spring loaded flat handle
- Nine position trigger handle
- 2-pc or between flanges available
- Air and electric actuators available
- Flanged ends available



For part numbers consult factory

[topln.co/butterfly](http://topln.co/butterfly)

# TOP-FLO®

## TF4 Ball Valves

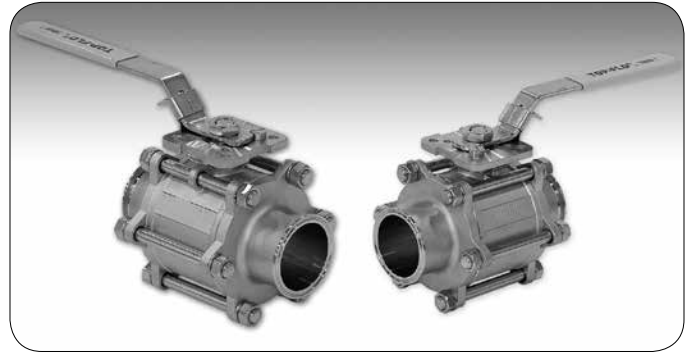

### Features:

- 360° Installation - valve may be installed in any position
- PTFE cavity fillers are precision machined to maintain sanitary environment.
- Easy "In-line" servicing. Unique design allows valve ends to remain attached while servicing valve body.
- No special tools needed
- Minimal turbulence - maximum flow through
- ISO 5211 Mounting Pad
- Surface finish ID: 20R<sub>a</sub>

### Mechanical Specifications:

- Sizes - 1/2" - 6"
- Materials - 316 SS
- PTFE seating
- Connections - clamp & butt weld (other connections available upon request)
- Locking handle
- Pressure - 1,000 psi @ 170°F sizes 1/2" - 2"  
800 psi @ 150°F sizes 2-1/2" - 4"  
250 psi @ 150°F size 6"
- Full port to ID of tubing for reduced pressure drop
- Pneumatic and electric actuators available

### Manual - Part Number Matrix

| MATERIAL |        | END CONNECTIONS |                      | VALVE SERIES |            | SIZE |       | SEAT MATERIAL |                              | HANDLE TYPE |                 |
|----------|--------|-----------------|----------------------|--------------|------------|------|-------|---------------|------------------------------|-------------|-----------------|
| 3        | 316 SS | 8               | C x C                | 43           | TF4 SERIES | 05   | 1/2   | TEF4          | CAVITY FILLED PTFE           | -           | STANDARD HANDLE |
|          |        | 9               | BW X BW              |              |            | 07   | 3/4   | NCF4          | NON-CAVITY FILLED PTFE       | G           | GEAR OPERATOR   |
|          |        | C               | C X BW               |              |            | 10   | 1     | SCF4          | NON-CAVITY FILLED 50/50 PTFE |             |                 |
|          |        | T               | WELD TANK FLANGE X C |              |            | 15   | 1-1/2 |               |                              |             |                 |
|          |        |                 |                      |              |            | 20   | 2     |               |                              |             |                 |
|          |        |                 |                      |              |            | 25   | 2-1/2 |               |                              |             |                 |
|          |        |                 |                      |              |            | 30   | 3     |               |                              |             |                 |
|          |        |                 |                      |              |            | 40   | 4     |               |                              |             |                 |
|          |        |                 |                      |              |            | 60   | 6     |               |                              |             |                 |

PART NUMBER EXAMPLE: 394320TEF4

TOP-FLO® 2" TF4 SERIES SANITARY 3-PC BALL VALVE, WELD ENDS, FDA PTFE CAVITY FILLED SEATS, 20R<sub>a</sub> ID, 316 SS, 1000 WOG

### Automated - Part Number Matrix

| MATERIAL |        | END CONNECTIONS |                      | VALVE SERIES |                  | SIZE |       | SEAT MATERIAL |                              | AUTOMATED TYPE |                                  |
|----------|--------|-----------------|----------------------|--------------|------------------|------|-------|---------------|------------------------------|----------------|----------------------------------|
| 3        | 316 SS | 8               | C x C                | 4            | TF4 SERIES 2-WAY | 05   | 1/2   | P             | CAVITY FILLED PTFE           | A1             | DOUBLE ACTING - 80 PSI SUPPLY    |
|          |        | 9               | BW X BW              |              |                  | 07   | 3/4   | N             | NON-CAVITY FILLED PTFE       | A2             | DOUBLE ACTING - 60 PSI SUPPLY    |
|          |        | C               | C X BW               |              |                  | 10   | 1     | S             | NON-CAVITY FILLED 50/50 PTFE | A3             | SS DOUBLE ACTING - 80 PSI SUPPLY |
|          |        | T               | WELD TANK FLANGE X C |              |                  | 15   | 1-1/2 |               |                              | A4             | SS DOUBLE ACTING - 60 PSI SUPPLY |
|          |        |                 |                      |              |                  | 20   | 2     |               |                              | S1             | SPRING RETURN - 80 PSI SUPPLY    |
|          |        |                 |                      |              |                  | 25   | 2-1/2 |               |                              | S2             | SPRING RETURN - 60 PSI SUPPLY    |
|          |        |                 |                      |              |                  | 30   | 3     |               |                              | S3             | SS SPRING RETURN - 80 PSI        |
|          |        |                 |                      |              |                  | 40   | 4     |               |                              | S4             | SS SPRING RETURN - 60 PSI        |
|          |        |                 |                      |              |                  | 60   | 6     |               |                              | E1             | 115VAC - 1PH, NEMA 4, 4X, 6      |
|          |        |                 |                      |              |                  |      |       |               |                              | E2             | 24VDC, NEMA 4, 4X, 6             |
|          |        |                 |                      |              |                  |      |       |               |                              | E3             | 220VAC - 1PH, NEMA 4, 4X, 6      |

PART NUMBER EXAMPLE: 38430PS1

TOP-FLO® 3" TF4 SERIES SANITARY 3-PC BALL VALVE, CLAMP ENDS, FDA PTFE CAVITY FILLED SEATS, 20R<sub>a</sub> ID, 316 SS, 800 WOG, WITH DIRECT MOUNT SPRING RETURN ACTUATOR SIZED FOR 80 PSI AIR SUPPLY

ALTERNATE END CONNECTIONS UPON REQUEST - CONSULT FACTORY FOR OPTIONS

# TOP-FLO<sup>®</sup> 3-Way Ball Valves (3-A)

## Features:

- Meets 3-A, FDA, USDA requirements
- PTFE cavity filler, fully encapsulated
- Locking device handle
- ISO-5211 direct mounting pad standard on all valves, (eliminates the need for brackets and couplers).
- Investment cast stainless steel CF8M (316)
- Surface finish ID: 25-30Ra
- Standard with clamp ends (other ends available upon request).
- Ball: T-Port or L-Port
- Sizes: 1/2" - 4"

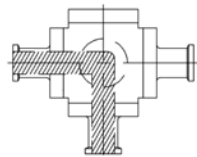
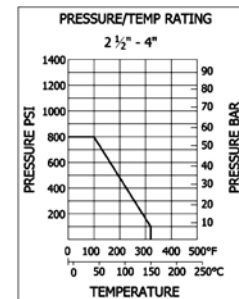
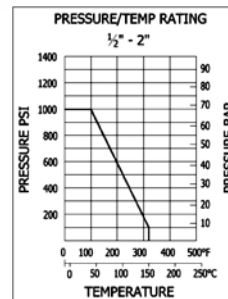
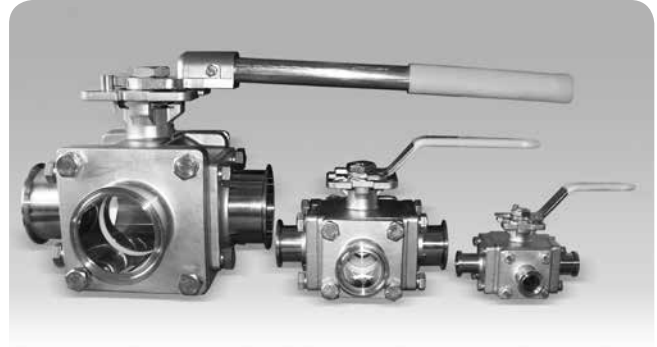

**L PORT**  
**(MANUAL) CLAMP-3863XXTEF1**  
**(MANUAL) WELD-3963XXTEF1**

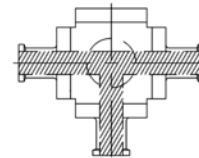

**T PORT**  
**(MANUAL) CLAMP-3853XXTEF1**  
**(MANUAL) WELD-3953XXTEF1**

| L-PATTERN BALL - POSITION ARRANGEMENTS |     |     |     |
|--|-----|-----|-----|
| # 1                                    | # 2 | # 3 | # 4 |
|  |     |     |     |

| T-PATTERN BALL - POSITION ARRANGEMENTS |     |     |     |
|--|-----|-----|-----|
| # 1                                    | # 2 | # 3 | # 4 |
|  |     |     |     |

## Automated Part Number Matrix

| MATERIAL | END CONNECTIONS | VALVE SERIES                     | POSITION CODE | SIZE  | SEAT MATERIAL   | AUTOMATION TYPE |                          |                               |                                  |    |     |    |                               |
|----------|-----------------|----------------------------------|---------------|-------|-----------------|-----------------|--------------------------|-------------------------------|----------------------------------|----|-----|----|-------------------------------|
| 3        | 316 SS          | 8                                | C X C X C     | 5     | T-PATTERN 3-WAY | P               | CAVITY FILLED PTFE SEATS | A1*                           | #1 - REST / #2 - AUTO (CCW TURN) | 05 | 1/2 | A1 | DOUBLE ACTING - 80 PSI SUPPLY |
|          |                 |                                  |               |       |                 |                 |                          | B1                            | #2 - REST / #3 - AUTO (CCW TURN) | 07 | 3/4 | A2 | DOUBLE ACTING - 60 PSI SUPPLY |
|          | C1              | #3 - REST / #4 - AUTO (CCW TURN) | 10            | 1     | S1              |                 |                          | SPRING RETURN - 80 PSI SUPPLY |                                  |    |     |    |                               |
|          | D1              | #4 - REST / #1 - AUTO (CCW TURN) | 15            | 1-1/2 | S2              |                 |                          | SPRING RETURN - 60 PSI SUPPLY |                                  |    |     |    |                               |
|          | E2              | #1 - REST / #4 - AUTO (CW TURN)  | 20            | 2     | E1              |                 |                          | 115VAC - 1PH, NEMA 4,4X,6     |                                  |    |     |    |                               |
|          | F2*             | #2 - REST / #1 - AUTO (CW TURN)  | 25            | 2-1/2 | E2              |                 |                          | 24VDC, NEMA 4,4X,6            |                                  |    |     |    |                               |
|          | G2              | #3 - REST / #2 - AUTO (CW TURN)  | 30            | 3     | E3              |                 |                          | 220VAC - 1PH, NEMA 4,4X,6     |                                  |    |     |    |                               |
|          | H2              | #4 - REST / #3 - AUTO (CW TURN)  | 40            | 4     |                 |                 |                          |                               |                                  |    |     |    |                               |

PART NUMBER EXAMPLE: 385D115PS2

TOP-FLO<sup>®</sup> 3-WAY SANITARY BALL VALVE, CLAMP ENDS, T-TYPE BALL, 1-1/2" FDA CAVITY FILLED SEATS, 25-30Ra ID, 316 SS, D1 POSITION, WITH DIRECT MOUNT SPRING RETURN ACTUATOR SIZED FOR 60 PSI AIR SUPPLY

\* POSITION CODES A1 & F2 ARE STANDARD ARRANGEMENTS FOR VALVE SERIES 6 (L-PATTERN 3-WAY)  
ALTERNATIVE POSITIONS & 180° AUTOMATION UPON REQUEST

# TOP-FLO® T4V V-Port Control Ball Valves



## Features:

- 360° Installation – valve may be installed in any position
- Easy “In-Line” servicing, 3-piece design allows valve ends to remain attached while servicing center valve components
- Surface finish ID: 20R<sub>a</sub>
- ID of valve is full port to OD Tubing dimensions
- 30° or 60° V-port ball options for desired flow characteristics
- Direct Mount ISO 5211 mounting pad
- Available in sizes 1/2" - 4"

| Manual Part Number Matrix |                 |                    |         |              |            |                      |            |      |                              |      |                        |   |               |
|---------------------------|-----------------|--------------------|---------|--------------|------------|----------------------|------------|------|------------------------------|------|------------------------|---|---------------|
| MATERIAL                  | END CONNECTIONS | V-PORT BALL DEGREE |         | VALVE SERIES | SIZE       | SEAT MATERIAL & TYPE |            |      | HANDLE TYPE                  |      |                        |   |               |
| 3                         | 316 SS          | 8                  | C X C   | V3           | 30° V-BALL | 43                   | TF4 SERIES | 05   | 1/2                          | TEF4 | CAVITY FILLED PTFE     | - | STANDARD      |
|                           |                 | 9                  | BW X BW | V6           | 60° V-BALL |                      |            | 07   | 3/4                          | NCF4 | NON-CAVITY FILLED PTFE | G | GEAR OPERATOR |
|                           |                 | C                  | C X BW  |              |            | 10                   | 1          | SCF4 | NON-CAVITY FILLED 50/50 PTFE |      |                        |   |               |
|                           |                 |                    |         |              |            | 15                   | 1-1/2      |      |                              |      |                        |   |               |
|                           |                 |                    |         |              |            | 20                   | 2          |      |                              |      |                        |   |               |
|                           |                 |                    |         |              |            | 25                   | 2-1/2      |      |                              |      |                        |   |               |
|                           |                 |                    |         |              | 30         | 3                    |            |      |                              |      |                        |   |               |
|                           |                 |                    |         |              | 40         | 4                    |            |      |                              |      |                        |   |               |

PART NUMBER EXAMPLE:  
**39V64315TEF4**

**TOP-FLO® 1-1/2" 3-PC SANITARY V-PORT SANITARY BALL VALVE, BUTT WELD ENDS, 60° V-BALL, FDA PTFE CAVITY FILLED SEATS, 20R<sub>a</sub> ID, 316 SS, LOCKABLE LEVER HANDLE, 1000 WOG**

| Automated Part Number Matrix |                 |                    |         |              |            |                      |            |    |                              |   |   |    |                               |
|------------------------------|-----------------|--------------------|---------|--------------|------------|----------------------|------------|----|------------------------------|---|---|----|-------------------------------|
| MATERIAL                     | END CONNECTIONS | V-PORT BALL DEGREE |         | VALVE SERIES | SIZE       | SEAT MATERIAL & TYPE |            |    | AUTOMATION TYPE              |   |   |    |                               |
| 3                            | 316 SS          | 8                  | C X C   | V3           | 30° V-BALL | 4                    | TF4 SERIES | 05 | 1/2                          | P   | CAVITY FILLED PTFE                        | A1 | DOUBLE ACTING - 80 PSI SUPPLY |
|                              |                 | 9                  | BW X BW | V6           | 60° V-BALL |                      |            | 07 | 3/4                          | N   | NON-CAVITY FILLED PTFE                    | A2 | DOUBLE ACTING - 60 PSI SUPPLY |
|                              |                 | C                  | C X BW  |              |            | 10                   | 1          | S  | NON-CAVITY FILLED 50/50 PTFE | S1  | SPRING RETURN - 80 PSI SUPPLY             |    |                               |
|                              |                 |                    |         |              |            | 15                   | 1-1/2      |    |                              | S2  | SPRING RETURN - 60 PSI SUPPLY             |    |                               |
|                              |                 |                    |         |              |            | 20                   | 2          |    |                              | EM1                                       | 115VAC - 1PH, NEMA 4, 4X 4-20MA MOD. CARD |    |                               |
|                              |                 |                    |         |              |            | 25                   | 2-1/2      |    |                              | EM2                                       | 24VDC, NEMA 4, 4X 4-20MA MOD. CARD        |    |                               |
|                              |                 |                    |         |              | 30         | 3                    |            |    | EM3                          | 220VAC - 1PH, NEMA 4, 4X 4-20MA MOD. CARD |   |    |                               |
|                              |                 |                    |         |              | 40         | 4                    |            |    |                              |   |   |    |                               |

PART NUMBER EXAMPLE:  
**38V3420PS1**

**TOP-FLO® 2" 3-PC SANITARY V-PORT SANITARY BALL VALVE, CLAMP ENDS, 30° V-BALL, FDA PTFE CAVITY FILLED SEATS, 20R<sub>a</sub> ID, 316 SS, 1000 WOG, WITH DIRECT MOUNT SPRING RETURN ACTUATOR SIZED FOR 80 PSI AIR SUPPLY**

## Positioners

| Part Number Matrix |  |  |  |          |                     |              |                    |  |           |   |                              |  |  |
|--------------------|--|--|--|----------|---------------------|--------------|--------------------|--|-----------|---|------------------------------|--|--|
| TYPE & SERIES      |  |  |  | SWITCHES |                     | TRANSMITTERS |                    |  | INDICATOR |   |                              |  |  |
| PP12               | PNEUMATIC 3-15 PSI INPUT               |  |  | XX       | (0) LIMIT SWITCHES  | XX           | NO TRANSMITTER     |  |           | P | POLY TUBE AIRLINE & FITTINGS |  |  |
| EP10               | ELECTRO-PNEUMATIC (IP66) 4-20 MA INPUT |  |  | LS       | (2) SPDT MECHANICAL | TR           | 4-20MA TRANSMITTER |  |           | S | SS AIRLINE & FITTINGS        |  |  |

PART NUMBER EXAMPLE:  
**EP10XXTRS**

EP ELECTRO-PNEUMATIC POSITIONER, 4-20MA INPUT SIGNAL, EP LIMIT SWITCHES, WITH 4-20MA TRANSMITTER, STAINLESS STEEL AIRLINE TUBE & FITTINGS, IP66 RATED, WITH MOUNTING KIT

\* Smart positioners and other types - contact factory

# Actuators

## TOP-FLO® TA Series for Ball & Butterfly Valves

### Features:

- Double acting and spring return models
- ISO 5211 valve mounting dimensions
- Corrosion resistant hard anodized finish
- Dual travel stops
- Various feedback switches & controls available



[topln.co/rpa](http://topln.co/rpa)

## TOP-FLO® Electric for Ball & Butterfly Valves

### Features:

- Multiple voltages available : 24VAC, 24VDC, and 115VAC single phase
- Nema 4, 4X & IP67 lightweight polyester powder coated aluminum housing
- External manual override
- Four limit switches – two for operation and two auxiliary dry contacts
- Anti-condensation space heater
- Visual position indicator
- Captive cover bolts



[topln.co/ea](http://topln.co/ea)

## TOP-FLO® Stainless Steel Canister for Butterfly Valves

### Features:

- 1/8" FNPT x 1/4" OD air connections for poly tube
- Stainless steel brackets & fasteners to withstand external washdown environments.
- Dual stacked coil springs that render reliable output torques to ensure valve closure.
- Visual indication is located on the coupler for easy valve position confirmation.
- Actuator operating pressure - 80 psi
- Air volume - 54 cubic inches
- Canister actuator for use on butterfly valves only



[topln.co/ca](http://topln.co/ca)

# TOP-FLO® K45MP Check Valves (3-A)

## Features:

- 3-A Certified
- Suitable for Process CIP fluids

## SPECIFICATIONS:

- Material: 316L SS
- End Connections: Clamp Weld (others upon request)
- Surface Finish: ID: 25-30Ra OD: 32Ra
- Seal Material: FDA FKM
- Maximum Operating Pressure: 150 PSIG
- Operating Temperature: 30°F Min. 225°F Max.



### Manual - Part Number Matrix

| MATERIAL & END CONNECTIONS |                            | SERIES |       | SIZE |       | SEAT MATERIAL |               | CONSTRUCTION |                                 |
|----------------------------|----------------------------|--------|-------|------|-------|---------------|---------------|--------------|---------------------------------|
| 38                         | 316L MATERIAL - CLAMP ENDS | K45    | K45MP | 05   | 1/2   | V             | 3-A & FDA FKM | A            | CONCENTRIC TYPE - STANDARD DISC |
| 39                         | 316L MATERIAL - WELD ENDS  |        |       | 07   | 3/4   |               |               | E            | ECCENTRIC TYPE - STANDARD DISC  |
|                            |                            |        |       | 10   | 1     |               |               |              |                                 |
|                            |                            |        |       | 15   | 1-1/2 |               |               |              |                                 |
|                            |                            |        |       | 20   | 2     |               |               |              |                                 |
|                            |                            |        |       | 25   | 2-1/2 |               |               |              |                                 |
|                            |                            |        |       | 30   | 3     |               |               |              |                                 |
|                            |                            | 40     | 4     |      |       |               |               |              |                                 |
|                            |                            | 60     | 6     |      |       |               |               |              |                                 |

PART NUMBER EXAMPLE: 38K4520VA

TOP-FLO® 2" K45MP CONCENTRIC DISC CHECK VALVE, CLAMP ENDS, FDA FKM SEALS, 25-30Ra ID, 316L SS

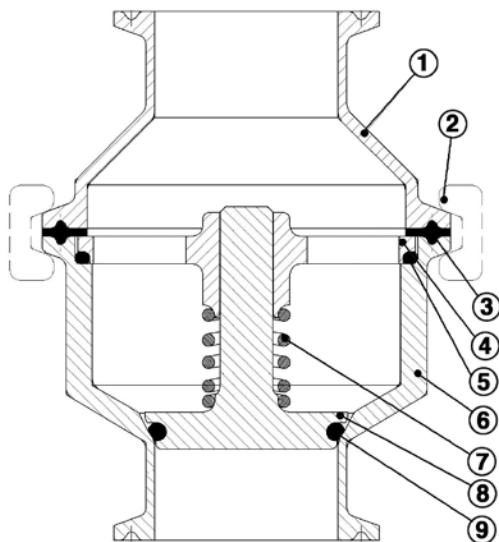

Body shapes vary by size.  
Go to [topln.co/check](http://topln.co/check) to see all sizes

| ITEM # | COMPONENT      | MATERIAL | PART #       |
|--------|----------------|----------|--------------|
| 1      | OUTLET BODY    | 316L     | N/A          |
| 2      | BODY CLAMP     | 304      | 3299915      |
| 3      | BODY GASKET*   | FDA FKM  | RKK15VA      |
| 4      | SPIDER         | 316L     | 38KSPIDER-15 |
| 5      | SPIDER O-RING* | FDA FKM  | RKK15VA      |
| 6      | INLET BODY     | 316L     | N/A          |
| 7      | SPRING         | 316L     | N/A          |
| 8      | DISC           | 316L     | 38KDISC-15   |
| 9      | DISC O-RING*   | FDA FKM  | RKK15VA      |

\* ITEMS ARE COMPONENTS OF ELASTOMER KIT  
(ITEMS NOT SOLD SEPARATELY)

NOTE: THE ABOVE PART NUMBERS ARE FOR 1-1/2" SIZES AVAILABLE 1/2" - 6"

[topln.co/check](http://topln.co/check)



# TOP-FLO® Plug Valves

## Features:

- Rubber (Silicone) or stainless steel plug
- Materials type 304 and 316L SS
- Meets 3-A sanitary finish
- Temperature to 100°F
- Bevel seat ends available upon request

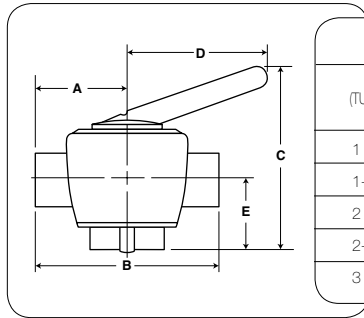

| DL10WW & DL10WWR 2-WAY PLUG VALVE BUTT WELD |         |         |         |         |         |                                       |  |                              |                               |
|---|---------|---------|---------|---------|---------|---------------------------------------|--|------------------------------|-------------------------------|
| SIZE (TUBE O.D.)                            | A       | B       | C       | D       | E       | 304 SS STOCK NO. STAINLESS STEEL PLUG | 316L SS STOCK NO. STAINLESS STEEL PLUG | 304 SS STOCK NO. RUBBER PLUG | 316L SS STOCK NO. RUBBER PLUG |
| 1   | 3-5/8   | 7-1/4   | 5-1/16  | 4-39/64 | 2-19/64 | 359610                                | 399610                                 | 359610R                      | 399610R                       |
| 1-1/2                                       | 3-29/32 | 7-13/16 | 6-7/16  | 5-5/8   | 2-13/32 | 359615                                | 399615                                 | 359615R                      | 399615R                       |
| 2   | 4-13/32 | 8-13/16 | 7-1/64  | 5-43/64 | 2-27/32 | 359620                                | 399620                                 | 359620R                      | 399620R                       |
| 2-1/2                                       | 5-1/8   | 10-1/4  | 8-51/64 | 5-59/64 | 3-25/64 | 359625                                | 399625                                 | 359625R                      | 399625R                       |
| 3   | 5-23/32 | 11-7/16 | 9-1/2   | 7-1/8   | 3-9/16  | 359630                                | 399630                                 | 359630R                      | 399630R                       |

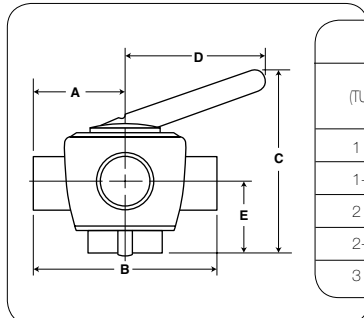

| DL11WWW & DL11WWWWR 3-WAY PLUG VALVE BUTT WELD |         |         |         |         |         |                                       |  |                              |                               |
|--|---------|---------|---------|---------|---------|---------------------------------------|--|------------------------------|-------------------------------|
| SIZE (TUBE O.D.)                               | A       | B       | C       | D       | E       | 304 SS STOCK NO. STAINLESS STEEL PLUG | 316L SS STOCK NO. STAINLESS STEEL PLUG | 304 SS STOCK NO. RUBBER PLUG | 316L SS STOCK NO. RUBBER PLUG |
| 1  | 3-5/8   | 7-1/4   | 5-1/16  | 4-39/64 | 2-19/64 | 359710                                | 399710                                 | 359710R                      | 399710R                       |
| 1-1/2  | 3-29/32 | 7-13/16 | 6-7/16  | 5-5/8   | 2-13/32 | 359715                                | 399715                                 | 359715R                      | 399715R                       |
| 2  | 4-13/32 | 8-13/16 | 7-1/16  | 5-43/64 | 2-27/32 | 359720                                | 399720                                 | 359720R                      | 399720R                       |
| 2-1/2  | 5-1/8   | 10-1/4  | 8-51/64 | 5-59/64 | 3-25/64 | 359725                                | 399725                                 | 359725R                      | 399725R                       |
| 3  | 5-23/32 | 11-7/16 | 9-1/2   | 7-1/8   | 3-9/16  | 359730                                | 399730                                 | 359730R                      | 399730R                       |

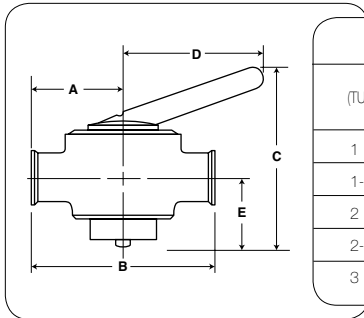

| D10MP & D10MPR 2-WAY PLUG VALVE CLAMP |         |         |         |         |         |                                       |  |                              |                               |
|---------------------------------------|---------|---------|---------|---------|---------|---------------------------------------|--|------------------------------|-------------------------------|
| SIZE (TUBE O.D.)                      | A       | B       | C       | D       | E       | 304 SS STOCK NO. STAINLESS STEEL PLUG | 316L SS STOCK NO. STAINLESS STEEL PLUG | 304 SS STOCK NO. RUBBER PLUG | 316L SS STOCK NO. RUBBER PLUG |
| 1                                     | 2-9/16  | 4-9/16  | 5-1/16  | 4-39/64 | 2-19/64 | 329610                                | 389610                                 | 329610R                      | 389610R                       |
| 1-1/2                                 | 2-29/32 | 5-13/16 | 6-7/16  | 5-5/8   | 2-13/32 | 329615                                | 389615                                 | 329615R                      | 389615R                       |
| 2                                     | 3-13/32 | 6-13/16 | 7-1/16  | 5-43/64 | 2-27/32 | 329620                                | 389620                                 | 329620R                      | 389620R                       |
| 2-1/2                                 | 4-1/8   | 8-1/4   | 8-51/64 | 5-59/64 | 3-25/64 | 329625                                | 389625                                 | 329625R                      | 389625R                       |
| 3                                     | 4-23/32 | 9-7/16  | 9-1/2   | 7-7/8   | 3-9/16  | 329630                                | 389630                                 | 329630R                      | 389630R                       |

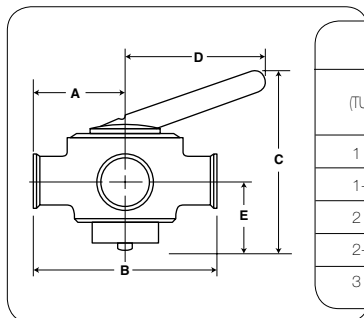

| D11MP & DM11MPR 3-WAY PLUG VALVE CLAMP |         |         |         |         |         |                                       |  |                              |                               |
|--|---------|---------|---------|---------|---------|---------------------------------------|--|------------------------------|-------------------------------|
| SIZE (TUBE O.D.)                       | A       | B       | C       | D       | E       | 304 SS STOCK NO. STAINLESS STEEL PLUG | 316L SS STOCK NO. STAINLESS STEEL PLUG | 304 SS STOCK NO. RUBBER PLUG | 316L SS STOCK NO. RUBBER PLUG |
| 1                                      | 2-9/16  | 4-9/16  | 5-1/16  | 4-39/64 | 2-19/64 | 329710                                | 389710                                 | 329710R                      | 389710R                       |
| 1-1/2                                  | 2-29/32 | 5-13/16 | 6-7/16  | 5-5/8   | 2-13/32 | 329715                                | 389715                                 | 329715R                      | 389715R                       |
| 2                                      | 3-13/32 | 6-13/16 | 7-1/16  | 5-43/64 | 2-27/32 | 329720                                | 389720                                 | 329720R                      | 389720R                       |
| 2-1/2                                  | 4-1/8   | 8-1/4   | 8-51/64 | 5-59/64 | 3-25/64 | 329725                                | 389725                                 | 329725R                      | 389725R                       |
| 3                                      | 4-23/32 | 9-7/16  | 9-1/2   | 7-7/8   | 3-9/16  | 329730                                | 389730                                 | 329730R                      | 389730R                       |

# TOP-FLO<sup>®</sup> Air Operated Flow Control Valves



**TOP-FLO<sup>®</sup> Single Sealing Shut-Off (3-A)**

**TOP-FLO<sup>®</sup> Single Sealing Divert (3-A)**

## FEATURES

---

- Patented PFA floating plug seal that is easily cleaned during CIP and offers outstanding sealing at high temperatures and excellent chemical resistance.
- Heavy duty stainless steel pneumatic actuator that is capable of function changes:  
NO (Normally Open) – NC (Normally Closed) – DA (Double Acting).
- Clamp style operator connection (manual and automated) for easy inspection and maintenance.
- Heavy wall machined spherical bodies guarantee excellent resistance to thermal expansion and contraction.
- Wide variety of body configurations: DCX3 (L) - (T) - (X) / DCX4 (L/L) - (L/T) – (T/L).



Definox  
DCX3 Automatic

Definox  
DCX4 Automatic

## SPECIFICATIONS

---

Size Range            1/2" - 6"

### Surface Finish

---

R<sub>a</sub> Interior = 32R<sub>a</sub>

### Materials

---

R<sub>a</sub> Exterior = 40-50R<sub>a</sub>

Body/Stem:            316L SS

Operator:              304 SS

Valve seals:            PFA floating plug seal  
FKM stem seal & body seal

# TOP-FLO® VDCI MC PMOC Mixproof Air Operated Flow Control Valves (3-A)

## Continuous Operation (7 days a week, 24 hours a day)

The design of DEFINOX VDCI MC PMO-C mixproof valve meets the 3-A recommendations (85-02) in accordance with dairy sanitary requirements. The PMO-C mixproof valve technology allows two different liquids to cross over in complete safety even during seat lifting operations.

**Production no longer needs to completely stop during cleaning operations.**

## Simple and high-tech design

- No need for an additional seal, due to an intermediate plug made from PEEK Thermoplastic (FDA approved).
- 3 identical O-rings which avoid risk of confusion between the spare parts during maintenance operations.
- The innovative design of the intermediate plug prevents turbulences into the leakage chamber and facilitates its correct positioning onto the lower plug.



## 3-A design

Valve technology complies with 3-A standard 85-02 which allows pasteurized milk in one chamber while CIP solution is flowing into the other chamber, without any risk of cross mixing. Another feature is to provide a leakage section identical to the one of the process pipeline.

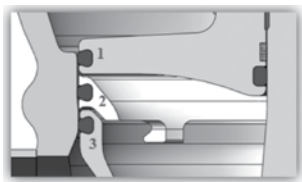

An intermediate plug 2 is inserted between the lower plug 3 and the upper plug 1 to prevent any risk of contamination between non compatible products during the seat lifting (such as milk and cleaning solutions).



This intermediate plug is made from a specific type of natural plastic called PEEK and approved by the FDA. This plastic is more resistant to high temperatures and high pressure.

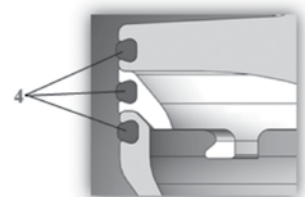

3 identical O-ring seals (4) mounted on each plug. No risk of mixing and easy maintenance.

In order to avoid any turbulence into the vent cavity, the position of legs for centering the intermediate plug is on the outside diameter.

Lifting of the upper plug

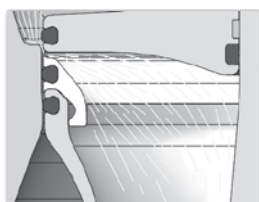

Lifting of the lower plug

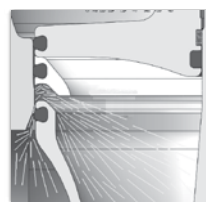

# TOP-FLO® Air Operated Flow Control Relief Valves

## TOP-FLO® Adjustable Relief DCX3

### Specifications

|                     |  |                 |   |
|---------------------|--|-----------------|---|
| Size Range:         | 1/2", 3/4", 1", 1-1/2", 2",<br>2-1/2", 3", 4"          | Materials       |   |
|                     |  | Body:           | 316L SS   |
|                     |  | Stem:           | 316L SS   |
| Service Conditions  |  | Operator:       | 304 SS  |
| Pressure tolerance: | +/- 15% of set pressure                                | Valve seals:    | PFA floating plug seal<br>FKM stem seal & body seal                         |
| Max. temperature:   | 248°F (depending on<br>seal type)                      | Optional seals: | EPDM, FKM, or Silicone<br>plug seal<br>EPDM or Silicone stem &<br>body seal |
| Min. temperature:   | 23°F   | Connections:    | OD Tube Butt Weld<br>Sanitary clamp   |
| Working pressure:   | 0 - 150 psi for 1" - 4"<br>0 - 174 psi for 1/2" & 3/4" |                 |   |



## TOP-FLO® Manual Pressure Relief

### Specifications

|                                |  |                 |  |
|--------------------------------|--|-----------------|--|
| Size Range:                    | 1-1/2", 2"                             | Materials       |  |
| Available springs              |  | Body:           | 316L SS                                    |
| #1 0-51 psi relief pressure    |  | Stem:           | 316L SS                                    |
| #2 44-110 psi relief pressure  |  | Operator:       | 304 SS                                     |
| #3 110-175 psi relief pressure |  | Valve seals:    | FKM plug seal<br>FKM stem seal & body seal |
| Service Conditions             |  | Optional seals: | EPDM plug seal<br>EPDM stem & body seal    |
| Max Temperature:               | +120°C/+248°F                          | Connections:    | OD Tube Butt Weld<br>Sanitary clamp        |
| Min. Temperature:              | 0°C/+32°F                              |                 |  |
| Adjustment range:              | 0 to 13 bar (1300kPa)/<br>0 to 189 psi |                 |  |



## TOP-FLO® Tank Service Vacuum-Pressure Relief

### Specifications

|                    |                |                                  |  |
|--------------------|----------------|----------------------------------|--|
| Size Range:        | 2", 2-1/2", 4" | Optional Pressure Relief Springs |  |
| Materials          |                |                                  |  |
| Body:              | 316L SS        |                                  |  |
| Plug:              | PTFE           |                                  |  |
| Valve seals:       | Silicone       |                                  |  |
| Connections:       | Sanitary clamp |                                  |  |
| Service Conditions |                |                                  |  |
| Max. Temperature:  | +80°C/+176°F   |                                  |  |
| Min. Temperature:  | 0°C/+32°F      |                                  |  |
| Vacuum:            | 30 mbar        |                                  |  |

| Size      | Spring | Relief Pressure |
|-----------|--------|-----------------|
| 2 & 2-1/2 | #1     | 10 psi          |
|           | #2     | 15 psi          |
|           | #3     | 20 psi          |
|           | #4     | 25 psi          |
|           | #5     | 35 psi          |
| 4         | #1     | 15 psi          |
|           | #2     | 25 psi          |
|           | #3     | 35 psi          |

Pressure relief spring # must be specified at time of order.

[topIn.co/relief](http://topIn.co/relief)



# TOP-FLO® Diaphragm Valves

**TOP-FLO®** hygienic diaphragm valves compete with the leaders in the industry and we can provide many innovative process solutions. Top Line offers standard 2-way, tandem assemblies in traditional L-Pattern & Sterile Access, ZERODL® block style assemblies in T-Pattern, Point-of-Use, Divert, and Integral L-Pattern & Sterile Access, actuation and accessories, forged or cast, 316L SS bodies.



## 2-Way Bodies

### BIOPRO® Forged



The **BIOPRO® Forged** bodies are manufactured in 316L SS from wrought bar with minimal levels of ferrite to eliminate concerns for contamination or rouging commonly experienced within a hygienic piping system.

- Sizes available 1/2" - 6"

### BIOPRO® Cast



The **BIOPRO® Cast** valves are commonly used for hygienic consumer products industries and select pharmaceutical applications.

**BIOPRO® Cast** bodies are manufactured in 316L SS (A351 CF3M).

- Sizes available 1-1/2" - 4"

### BIOFLO® II Compact



The **BIOFLO® II Compact** valve body is specifically designed for the prevention of media contamination in ultra pure applications within the bioprocessing industry. **BIOFLO® II Compact** valve bodies are available with 1/2", 3/8", 1/4" clamp or weld end connections.

## Diaphragms



Each **TOP-FLO® Diaphragm Valve** can be supplied with a wide variety of elastomer or MPTFE faced materials. All diaphragms are compliant with FDA codes and USP Class VI standards and are fully traceable.

Diaphragms are molded in both the open and closed position dependant on type. All elastomer type diaphragms are attached to the compressor by a threaded stud. MPTFE diaphragms are attached by a bayonet type fixture that eliminates point loading, thus providing constant diaphragm compression across the weir resulting in a more uniform and reliable seal.

### ALL TOP-FLO® DIAPHRAGM VALVES FEATURE:

- Full traceability
- Self draining
- 316L SS bodies (1.4435)
- Stainless steel bonnets
- Pneumatic actuators
- FDA/USP compliant diaphragms

# TOP-FLO® Sample Valves

## Standard Features:

- 316L SS wetted part construction
- Standard finish: 20Ra, ID (SF1)/ 32Ra OD
- Replaceable tapered FDA/USP Class VI, PTFE stem for positive closure
- FDA/USP Class VI, FKM O-ring stem seal
- Positive open stop to prevent accidental stem removal during operation
- Fully autoclaveable without disassembly
- Thermoplastic black operator nut
- Full material traceability

## Optional Features:

- Upgraded internal finish to 20Ra W/EP (SF5) or 15Ra W/EP (SF4)
- Other material grades available upon request
- FDA/USP Class VI, EPDM O-ring stem seal
- Alternative end connections upon request
- Eccentric

## Service Conditions:

- Maximum operating temperature: 300°F
- Maximum operating pressure: 400 PSIG
- Maximum SWP: 35 PSIG SWP @ 280°F



| Part Number Matrix         |          |                |                |                       |                   |                   |
|----------------------------|----------|----------------|----------------|-----------------------|-------------------|-------------------|
| TYPE                       | MATERIAL | INTERNAL STEM  | STEM O-RING    | MAIN VALVE CONNECTION | OUTLET CONNECTION | ID SURFACE FINISH |
| SV2 RIGHT ANGLE CONCENTRIC | 6 316L   | T FDA/USP PTFE | E FDA/USP EPDM | 50 1/2                | A 1/4 HOSE BARB   | SF1 20Ra          |
|                            |          |                | V FDA/USP FKM  | 75 3/4                | B 3/8 HOSE BARB   | SF4 15Ra W/EP     |
| EV2* RIGHT ANGLE ECCENTRIC |          |                |                | 10 1                  | C 1/2 HOSE BARB   | SF5 20Ra W/EP     |
|                            |          |                |                | 15 1-1/2              | D 1/2 CLAMP       |                   |
| IN2** IN-LINE              |          |                |                | 20 2                  |                   |                   |
|                            |          |                |                | 25 2-1/2              |                   |                   |
|                            |          |                |                | 30 3                  |                   |                   |
|                            |          |                |                | 40 4                  |                   |                   |
|                            |          |                |                | 60 6                  |                   |                   |
|                            |          |                |                |                       |                   |                   |

PART NUMBER EXAMPLE: SV26TV15BSF1

TOP-FLO® 2" Right Angle Concentric Sample Valve, 316L, FDA/USP PTFE, FDA/USP FKM, 1-1/2", 3/8" Hose Barb, 20Ra

\* EV2 VALVES ONLY AVAILABLE WITH MAIN CONNECTION SIZE 1-1/2" - 6"

\*\* IN2 VALVES ONLY AVAILABLE WITH HOSE BARB OUTLET CONNECTION

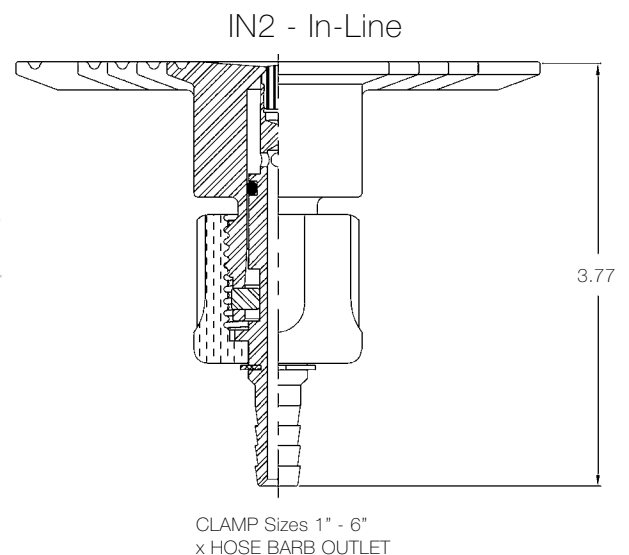
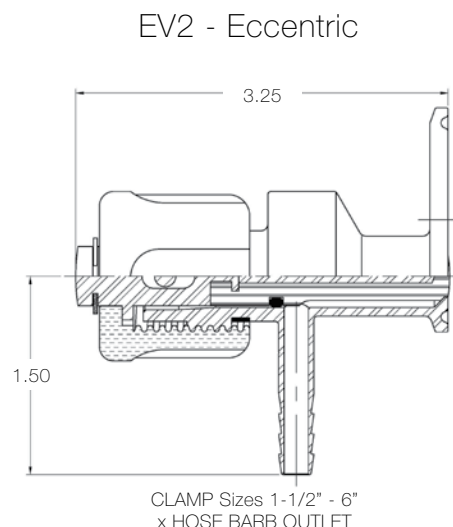
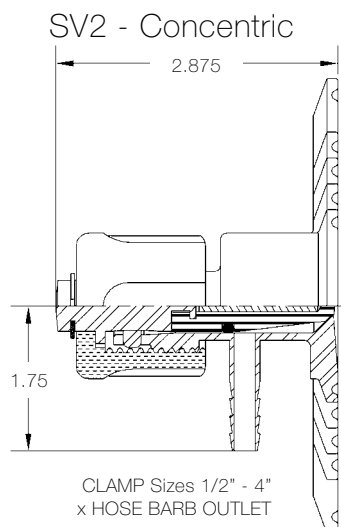

# TOP-FLO<sup>®</sup> Ball Check Valves

TOP-FLO<sup>®</sup> sanitary ball check valves are used to prevent the backflow of fluid in sanitary systems and to minimize pressure drop across the valve. The vertical installation orientation of TOP-FLO<sup>®</sup> ball check valves utilizes the fluid head pressure behind the ball when there is zero flow and valve is in the closed position to ensure positive shut off across the elastomer seat.

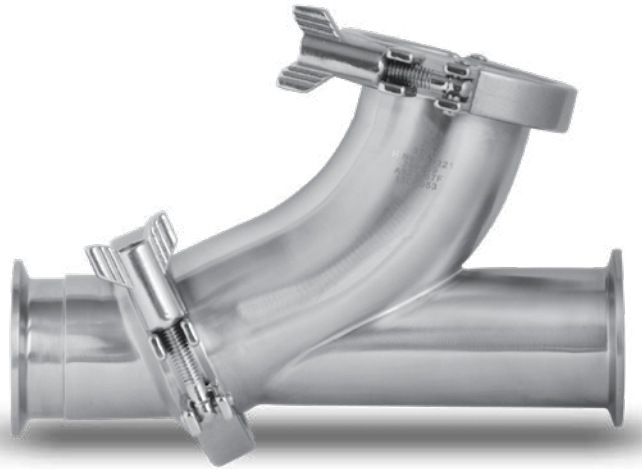

## FEATURES:

- 3-A Certified
- Replaceable elastomer seat due to 2-pc design
- Suitable for both process and CIP fluids
- Wetted construction in 316L SS material
- Standard size seat & body clamp

## SPECIFICATIONS:

- End Connections: Clamp
- Seat & Seal Material: FDA FKM (Standard)  
FDA EPDM (Optional)
- Ball Material: FDA Virgin PTFE
- Surface Finish: ID: 25-30R<sub>a</sub>  
OD: 32R<sub>a</sub>
- Maximum Operating Pressure: 150 PSIG
- Operating Temperature: 30° F Min.  
200° F Max.

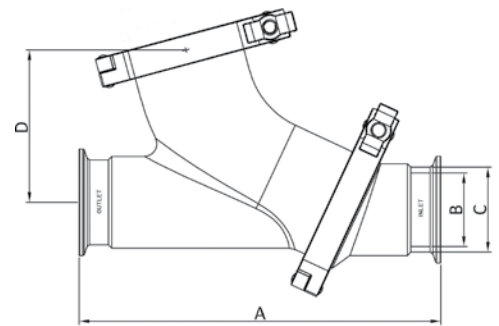

## Dimensions

| VALVE SIZE | CLAMP SIZES |      |      |      |            |            |
|------------|-------------|------|------|------|------------|------------|
|            | A           | B    | C    | D    | SEAT CLAMP | BODY CLAMP |
| 1-1/2      | 7.50        | 1.37 | 1.50 | 3.30 | 2.00       | 2.00       |
| 2          | 8.50        | 1.87 | 2.00 | 3.90 | 2.50       | 2.50       |
| 2-1/2      | 10.00       | 2.37 | 2.50 | 4.50 | 3.00       | 3.00       |
| 3          | 11.50       | 2.87 | 3.00 | 5.30 | 4.00       | 4.00       |

## Part Number Matrix

| CONNECTIONS / MATERIAL |                                | VALVE TYPE | VALVE SIZE |    | SEAT/SEAL MATERIAL |   | BALL MATERIAL |   |          |
|------------------------|--------------------------------|------------|------------|----|--------------------|---|---------------|---|----------|
| 38                     | CLAMP ENDS - 316L CONSTRUCTION | 4          | 45BYMP     | 15 | 1-1/2              | F | FDA FKM       | P | FDA PTFE |
|                        |                                |            |            | 20 | 2                  | E | FDA EPDM      |   |          |
|                        |                                |            |            | 25 | 2-1/2              |   |               |   |          |
|                        |                                |            |            | 30 | 3                  |   |               |   |          |

## Kits and Parts

| VALVE SIZE | SEAL KIT   |            | REPAIR KIT |            | ADDITIONAL REPLACEMENT PARTS |            |            |              |
|------------|------------|------------|------------|------------|------------------------------|------------|------------|--------------|
|            | FKM        | EPDM       | FKM        | EPDM       | COMPONENT PART #             |            |            |              |
|            | PART #     | PART #     | PART #     | PART #     | PTFE BALL ONLY               | SEAT CLAMP | BODY CLAMP | BODY END CAP |
| 1-1/2      | 38415FP-SK | 38415EP-SK | 38415FP-RK | 38415EP-RK | 38415BALL-P                  | 3299920    | 3299920    | 389820       |
| 2          | 38420FP-SK | 38420EP-SK | 38420FP-RK | 38420EP-RK | 38420BALL-P                  | 3299925    | 3299925    | 389825       |
| 2-1/2      | 38425FP-SK | 38425EP-SK | 38425FP-RK | 38425EP-RK | 38425BALL-P                  | 3299930    | 3299930    | 389830       |
| 3          | 38430FP-SK | 38430EP-SK | 38430FP-RK | 38430EP-RK | 38430BALL-P                  | 3299940    | 3299940    | 389840       |

SEAL KITS INCLUDE  
 (1) ELASTOMER/CF8M SEAT  
 (1) ELASTOMER BODY GASKET

REPAIR KITS INCLUDE  
 (1) VIRGIN PTFE BALL  
 (1) ELASTOMER/CF8M SEAT  
 (1) ELASTOMER BODY GASKET

[topln.co/ballcheck](http://topln.co/ballcheck)



# TOP-FLO® Air Blow Check Valves

TOP-FLO® 62-174R Air Blow Check Valves are designed to evacuate lines of product or CIP solution, and for air agitation of product in tanks and other vessels.

- The valve helps to protect pipelines against corrosion - air drying of lines permits formation of the protective oxide film.
- Improves product uniformity and quality - product air agitation thoroughly mixes and blends product.

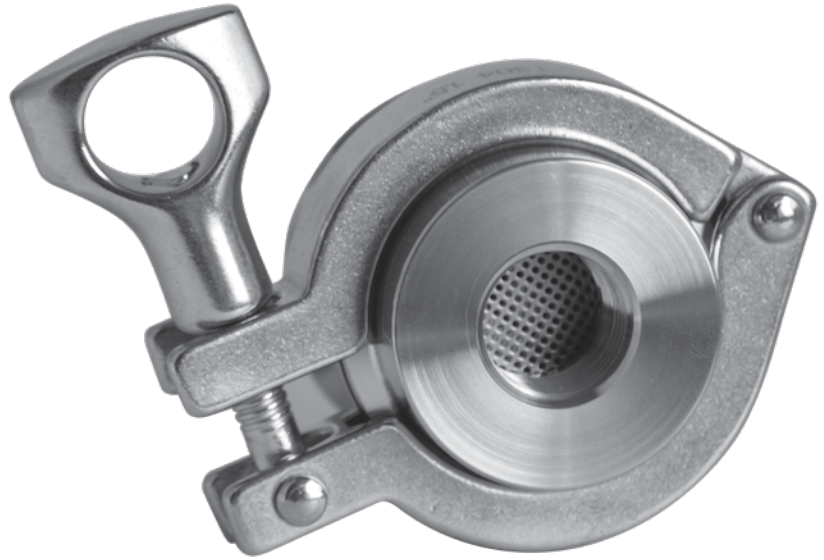

## Features:

- Fail Safe Operation - backflow of product or CIP solution prevented by simple air to open, spring to close operation.
- Easy Assembly/Disassembly - connections permit quick disassembly and assembly for replacing filter media, cleaning or inspection. Quick couple or FNPT air connection.
- EPDM stopper
- Clamp sizes 1-1/2 - 4"
- All 316L SS body construction
- Remotely Controlled - can be remotely controlled by controlling the supply of air to the valve.
- Rugged Construction - type 316L stainless steel is standard. Spherical plug assembly is bonded EPDM rubber.
- Conforms to 3-A accepted practices - for applications requiring a final filtering of air prior to entering a tank or pipelines.

## Specifications:

Capacity to 1600 CFH air volume

### PART NUMBER MATRIX

| OUTLET CONNECTION / MATERIAL |                         | CLAMP SIZE |         | STOPPER ELASTOMER |          | INLET CONNECTION |                      | VALVE SERIES |                     |
|------------------------------|-------------------------|------------|---------|-------------------|----------|------------------|----------------------|--------------|---------------------|
| 3846                         | SANITARY CLAMP - 316LSS | 15         | 1 1/2"  | 0                 | FDA EPDM | 1                | QUICK COUPLE ADAPTER | 174          | 62-174R CHECK VALVE |
|                              |                         | 20         | 2"      |                   |          | 2                | 1" HOSE BARB         |              |                     |
|                              |                         | 25         | 2 1/2"  |                   |          | 3                | 3/8" FNPT            |              |                     |
|                              |                         | 30         | 3"      |                   |          | 4                | 1/2" FNPT            |              |                     |
|                              |                         | 35         | 3" SCH5 |                   |          | 5                | 3/4" FNPT            |              |                     |
|                              |                         | 40         | 4"      |                   |          | 6                | 1/4" FNPT            |              |                     |
|                              |                         | 45         | 4" SCH5 |                   |          |                  |                      |              |                     |

PART NUMBER EXAMPLE:  
38463003174

TOP-FLO® 3" 62-174R Air Blow Check Valve, 3/8" Fmpt Inlet X Clamp Outlet, FDA EPDM Stopper, PTFE Guide, 32R<sub>a</sub> ID, 316L

# Tubing (3-A)

Top Line maintains a large inventory of welded stainless steel tubing to meet your immediate needs. Our warehouse is able to quickly ship tubing in lengths up to 20'. Each tubing order is processed promptly and packaged in tri-wall corrugated cartons equipped with wooded ends to protect each piece from damage.

Applications which require only the finest in tubing, with close adherence to tolerances, readily prefer tubing from Top Line. We pride ourselves on providing the finest tubing at a competitive price. Tubing types 304 and 316L SS are available in sizes from 1/2" OD - 8" OD produced to ASTM specifications A249, A269, or A270. Pharmaceutical grade tubing is also available. Go to [topln/bpetubing](#) for details.

## Advantages

- Meets the 3-A Standard
- Certified - ASTM A249/A269/A270

## Features

- Surface Finish - 30Ra ID on 1/2" - 20Ra ID on 3/4" - 4 with 30Ra OD on all
- Lengths - Standard 20' 0" (+1" - 0)
- Controlled Sulfur - .005 - .017 on 316L

## ORDERING INFORMATION

| Size  | 304          | 316L         | Guage | Wall | Lbs/Ft |
|-------|--------------|--------------|-------|------|--------|
| 1/2   | 3105654 -7TL | 3105656 -7TL | 16    | .065 | .3020  |
| 3/4   | 3107654 -7TL | 3107656 -7TL | 16    | .065 | .4755  |
| 1     | 3110654 -7TL | 3110656 -7TL | 16    | .065 | .6490  |
| 1-1/2 | 3115654 -7TL | 3115656 -7TL | 16    | .065 | .9962  |
| 2     | 3120654 -7TL | 3120656 -7TL | 16    | .065 | 1.343  |
| 2-1/2 | 3125654 -7TL | 3125656 -7TL | 16    | .065 | 1.690  |
| 3     | 3130654 -7TL | 3130656 -7TL | 16    | .065 | 2.037  |
| 4     | 3140834 -7TL | 3140836 -7TL | 14    | .083 | 3.472  |
| 6     | 3160194T-7   | 3160196T-7   | 12    | .109 | 6.920  |
| 8     | 3180194T-7   | 3180196T-7   | 12    | .109 | 9.272  |

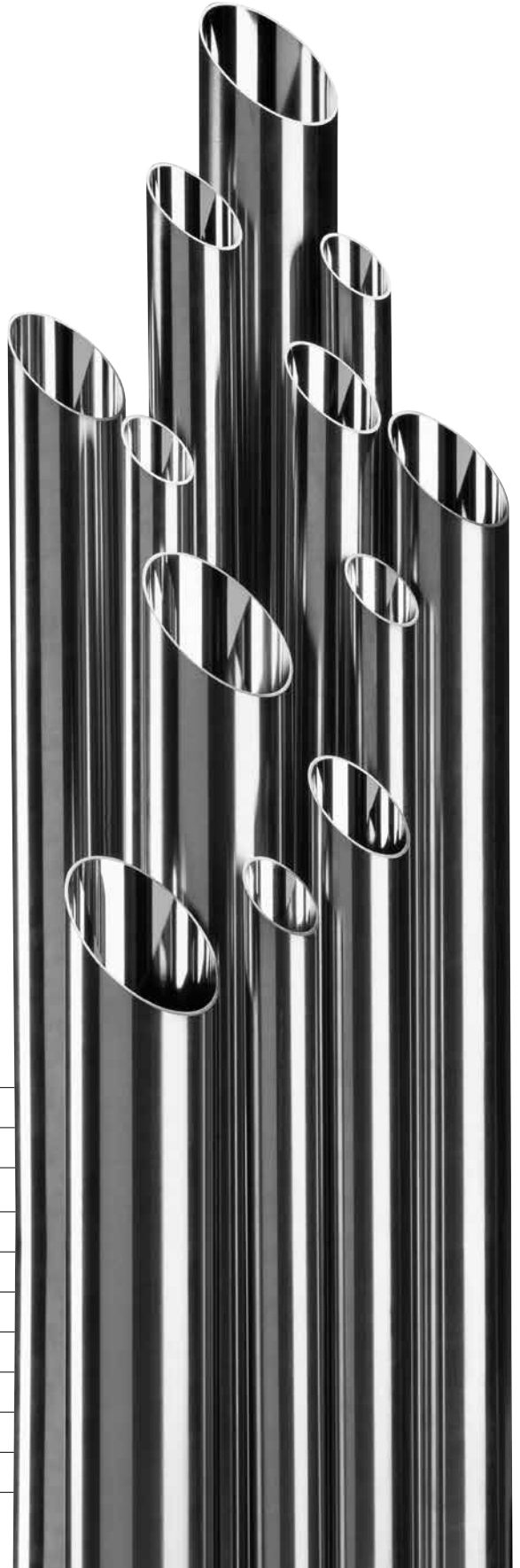

# Hangers

Top Line hangers install easily and provide secure mounting for a wide variety of tubing sizes.

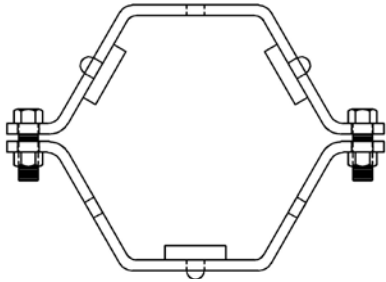

B24W Tubing Hanger

| SIZE (TUBE O.D.) | STOCK NO. | HANGER W/POLY PRO |
|------------------|-----------|-------------------|
| 1/2              | 32D-05    | 32D-05PP          |
| 3/4              | 32D-07    | 32D-07PP          |
| 1                | 32D-10    | 32D-10PP          |
| 1-1/2            | 32D-15    | 32D-15PP          |
| 2                | 32D-20    | 32D-20PP          |
| 2-1/2            | 32D-25    | 33D-25PP          |
| 3                | 32D-30    | 32D-30PP          |
| 4                | 32D-40    | 32D-40PP          |
| 6                | 32D-60    | 32D-60PP          |
| 8                | 32D-80    | -                 |
| 10               | -         | -                 |
| 12               | -         | -                 |

Threads shown for clarity → 3/8" FNPT Coupling

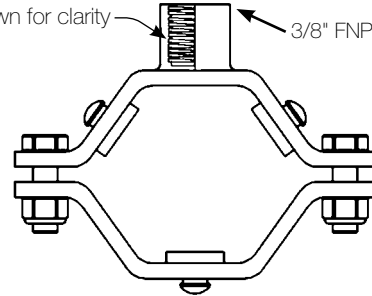

C24T Tubing Hanger

| SIZE (TUBE O.D.) | STOCK NO. | HANGER W/POLY PRO |
|------------------|-----------|-------------------|
| 1/2              | 32C-05    | -                 |
| 3/4              | 32C-07    | -                 |
| 1                | 32C-10    | 32C-10PP          |
| 1-1/2            | 32C-15    | 32C-15PP          |
| 2                | 32C-20    | 32C-20PP          |
| 2-1/2            | 32C-25    | 32C-25PP          |
| 3                | 32C-30    | 32C-30PP          |
| 4                | 32C-40    | 32C-40PP          |
| 6                | 32C-60    | 32C-60PP          |
| 8                | -         | -                 |
| 10               | -         | -                 |
| 12               | -         | -                 |

3/8" or 1/2" standard threads available upon request

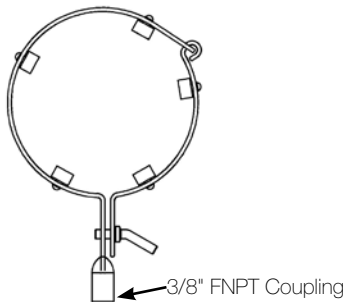

A24FCF Tubing Hanger

| SIZE (TUBE O.D.) | STOCK NO. |
|------------------|-----------|
| 1                | 32A2410   |
| 1-1/2            | 32A2415   |
| 2                | 32A2420   |
| 2-1/2            | 32A2425   |
| 3                | 32A2430   |
| 4                | 32A2440   |

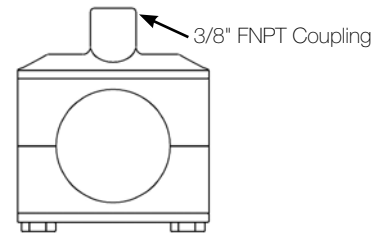

Many new sizes and styles available

[topln.co/hangerscast](http://topln.co/hangerscast)

[topln.co/hangersdual](http://topln.co/hangersdual)

[topln.co/hangersquad](http://topln.co/hangersquad)

# TOP-FLO® Custom Fabrications



Top Line's skilled craftsmen and specialized equipment combine to produce a wide variety of custom fabricated stainless steel process flow components. All specials are made to customer requirements and are available in a wide variety of sanitary finishes. Fast service is assured.

Fabrication Shop can make the part you need. We pride ourselves on our superior craftsmanship and prompt service.

- Special Tees
- Custom Fittings
- Manifolds
- Machined Parts
- Special Finishes
- Flange Adapters
- Spool Pieces

[topln.co/custom](http://topln.co/custom)

## Electropolishing Services

Electropolishing is an electrochemical process that removes surface metal by attacking the high points on the surface. The surface becomes smoother and any contaminants and free irons will be removed. This will improve the corrosion resistance, reduce the product adhesion and contamination buildup, deburr, and create a lustrous finish.



[topln.co/electropolishing](http://topln.co/electropolishing)

# TOP-FLO® Filters & Strainers

**TOP-FLO®** in-line stainless steel filters and strainers are specifically designed for the removal of unwanted particles from process line content providing added protection and longer service life for pumps, valves, heat exchangers, and other processing equipment.

Constructed of corrosion-fighting 316L SS, **TOP-FLO®** in-line filters and strainers feature a sanitary design plus ease of installation and quick cleanup. These rugged, yet lightweight strainers are available in two lengths and are interchangeable with other comparable strainers.

The **TOP-FLO®** strainer is ideally suited for hygienic process applications including dairy, food, beverage, pharmaceutical, and biotechnology.

## TOP-FLO® Dimensions (inches)

|       | Connection Size | Length (in.) | Diameter (in.) | Effective Filter Area (ft. <sup>2</sup> ) | Parts Number |
|-------|-----------------|--------------|----------------|---|--------------|
| Short | 1               | 15-3/4       | 4              | 0.65                                      | SM 1-10      |
|       | 1-1/2           | 15-3/4       | 4              | 0.65                                      | SM 1-15      |
|       | 2               | 15-3/4       | 4              | 0.65                                      | SM 1-20      |
|       | 2-1/2           | 15-3/4       | 4-1/2          | 0.75                                      | SM 1-25      |
|       | 3               | 15-3/4       | 4-1/2          | 0.75                                      | SM 1-30      |
| Long  | 1-1/2           | 35-3/8       | 4              | 1.95                                      | SM 2-15      |
|       | 2               | 35-3/8       | 4              | 1.95                                      | SM 2-20      |
|       | 2-1/2           | 35-3/8       | 4-1/2          | 2.25                                      | SM 2-25      |
|       | 3               | 35-3/8       | 4-1/2          | 2.25                                      | SM 2-30      |

**Example:**  
A model SM2-25 is a 316L SS inlet long strainer with 2.5" clamp connections

**Notes:**  
The standard perforated back-up tube with .25" holes is provided with the unit. Top Line also has .125" perforated back-up tube upon request. overscreens and filter media are not provided with the unit and must be ordered separately.

**Material Traceability:**  
**Material Test Reports are available for inlet housing and outlet cap.**  
**Certificate of Compliance for 316L material is available for the distributor cap, spring, and back-up tube.**



Top Line offers in-line strainers in short 15-3/4" OAL and long 35-3/8" OAL. Standard filters for fine particle removal - 765 micron to 40 micron offered. A reusable wire mesh overscreen is offered for strainers where larger particle removal - 1905 micron to 73 micron is needed.

## Replacement Strainer Selection

| Perforated Metal Strainer Single Screened |                 |                  |       |                     |                       |                |
|---|-----------------|------------------|-------|---------------------|-----------------------|----------------|
|   | Screen Part No. | Port Connections | Gauge | Hole Diameter (in.) | Holes Per Square Inch | % of Open Area |
| Short                                     | BTS-1020        | 1                | 14    | 1/4 / .250          | 9                     | 58             |
|   | BTS-1020        | 1-1/2            | 14    | 1/4 / .250          | 9                     | 58             |
|   | BTS-1020        | 2                | 14    | 1/4 / .250          | 9                     | 58             |
|   | BTS-2530        | 2-1/2            | 12    | 1/4 / .250          | 9                     | 58             |
|   | BTS-2530        | 3                | 12    | 1/4 / .250          | 9                     | 58             |
| Long                                      | BTL-1020        | 1-1/2            | 14    | 1/4 / .250          | 9                     | 58             |
|   | BTL-1020        | 2                | 14    | 1/4 / .250          | 9                     | 58             |
|   | BTL-2530        | 2-1/2            | 12    | 1/4 / .250          | 9                     | 58             |
|   | BTL-2530        | 3                | 12    | 1/4 / .250          | 9                     | 58             |

1/8 / .125 hole diameter perforated back up tube upon request



### Filtration

**TOP-FLO®** filters can be furnished with any one of seven filtering media down to 40 microns including non-woven rayon, cotton, cheesecloth, nylon mesh, and woven nylon.

## Wire Cloth Mesh Over Screens

| Screen Part No. | Square Mesh Size | Space Between Wires (in.) | Micron Rating | % of Open Area |
|-----------------|------------------|---------------------------|---------------|----------------|
| OS16-XX         | 16               | 0.045                     | 1130          | 50.7           |
| OS20-XX         | 20               | 0.034                     | 864           | 46.2           |
| OS30-XX         | 30               | 0.021                     | 533           | 40.8           |
| OS40-XX         | 40               | 0.015                     | 381           | 36.0           |
| OS50-XX         | 50               | 0.011                     | 279           | 30.3           |
| OS60-XX         | 60               | 0.009                     | 229           | 30.3           |
| OS80-XX         | 80               | 0.007                     | 178           | 31.4           |
| OS100-XX        | 100              | 0.006                     | 140           | 30.3           |
| OS120-XX        | 120              | 0.005                     | 117           | 30.7           |
| OS150-XX        | 150              | 0.004                     | 104           | 37.4           |

Prefix: S - Short, L - Long    Suffix: 1020 - 1"-2", 2530 - 2-1/2"-3"  
Example: SOS16-2530 - Short Over Mesh, #16, for 2-1/2" and 3" Strainer



### Fine or Medium Strainer

Complete with a backup tube and overscreen with small perforations or wire mesh for removing finer particles (73 - 1130 microns).

## Replacement Filter Media Schedule

| Media   | Micron Rating* | Description           |
|---------|----------------|-----------------------|
| F40-XX  | 40             | NON-WOVEN RAYON       |
| F80-XX  | 80             | POLYESTER SCREEN      |
| F150-XX | 150            | POLYESTER SCREEN      |
| F250-XX | 250            | SMOOTH WEAVE DACRON   |
| F300-XX | 300            | COTTON CHEESE CLOTH   |
| F350-XX | 350            | POLYESTER KNIT        |
| F400-XX | 400            | PLAIN WEAVE POLYESTER |
| F500-XX | 500            | COTTON FLANNEL        |
| F765-XX | 765            | NYLON LENO            |

\*Average

Prefix: S - Short, L - Long    Suffix: 1020 - 1"-2", 2530 - 2-1/2"-3"  
Example: LF350-1020 - Long Filter Media, 350 Micron Polyester Knit for 1"-2" Filter



### Coarse Strainer

Furnished with a single perforated screen for straining large particles.

\* Other materials and back-up tube sizes available upon request.

# Sanitary Pressure Gauges (3-A)

Hygienic pressure gauges have been specifically designed for applications in the food, dairy, pharmaceutical, and biotechnology industries. These gauges meet 3-A, USDA and FDA sanitary standards.

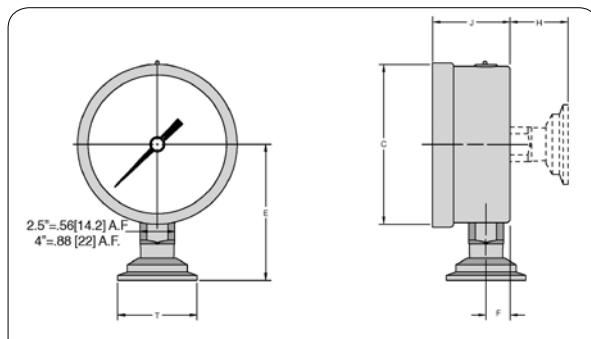

| DIAL SIZE | CLAMP SIZE | C            | E         | F           | H           | J           | T           |
|-----------|------------|--------------|-----------|-------------|-------------|-------------|-------------|
| 2-1/2     | 1-1/2      | 2.68 (68)    | 2.64 (67) | 0.37 (9.5)  | 1.52 (38.5) | 1.20 (30.5) | 1.98 (50.5) |
| (63)      | 2          | 2.68 (68)    | 2.64 (67) | 0.37 (9.5)  | 1.52 (38.5) | 1.20 (30.5) | 2.51 (64.0) |
| 4         | 1-1/2      | 4.18 (106.2) | 3.35 (85) | 0.46 (11.8) | 1.52 (38.5) | 1.32 (33.5) | 1.98 (50.5) |
| (100)     | 2          | 4.18 (106.2) | 3.35 (85) | 0.46 (11.8) | 1.52 (38.5) | 1.32 (33.5) | 2.51 (64.0) |

## Ranges

|        |     |       | DIAL FACE   |         |             |         |
|--------|-----|-------|-------------|---------|-------------|---------|
|        |     |       | 2-1/2       |         | 4           |         |
|        |     |       | 1-1/2 CLAMP | 2 CLAMP | 1-1/2 CLAMP | 2 CLAMP |
| PSI    | BAR | MOUNT | 1-1/2 CLAMP | 2 CLAMP | 1-1/2 CLAMP | 2 CLAMP |
| 30\"/> |     |       |             |         |             |         |

Options available upon request:

- Other pressure ranges
- No fill (dry)

## SPECIFICATIONS

- Case: polished AISI 304 SS
- Ring: polished AISI 304 SS
- Dial sizes: 2-1/2" and 4"
- Process connection (T): polished AISI 316L SS with 1-1/2" and 2" clamp connections.
- Diaphragm: polished AISI 316L SS
- Polycarbonate face
- Pointer: black anodized aluminum
- Case fill: glycerine
- Seal fill: oil for food service
- Process temperature: 150°F max
- Accuracy: as a percentage of full scale as per ASME B40.100 ± 1% (4" Dial) as per ASME B40.100 ± 1.6% (2-1/2" Dial)



# Sanitary Sight Glasses

Top Line's In-line sight glasses are engineered to be the best in the industry. The bolt style allows for fast, continuous inspection from all angles. The flange style sight glass incorporates a large viewing window for easy flow inspection. Top Line In-Line sight glasses are available in sizes 1/2" through 4".



## Features:

- Clear acrylic tube insert
- Constructed of 316L SS
- Clamp end connections - standard
- FDA white Buna gaskets - standard
- Suitable for CIP and fully drainable

## Options:

- Borosilicate glass insert
- Shielded bolt style - clear acrylic protective shell providing additional protection from falling objects
- Other end connections available upon request
- FDA EPDM or FDA FKM gaskets upon request

| Size<br>(Tube O.D.) | Dimension<br>A | STOCK NO.  |                     |
|---------------------|----------------|------------|---------------------|
|                     |                | Bolt Style | Bolt Style w/Shield |
| 1/2                 | N/A            | N/A        | N/A                 |
| 3/4                 | N/A            | N/A        | N/A                 |
| 1                   | 5-7/8          | 381910B    | 381910BSG           |
| 1-1/2               | 5-7/8          | 381915B    | 381915BSG           |
| 2                   | 5-7/8          | 381920B    | 381920BSG           |
| 2-1/2               | 6-3/8          | 381925B    | 381925BSG           |
| 3                   | 7-1/2          | 381930B    | 381930BSG           |
| 4                   | 7-5/8          | 381940B    | 381940BSG           |

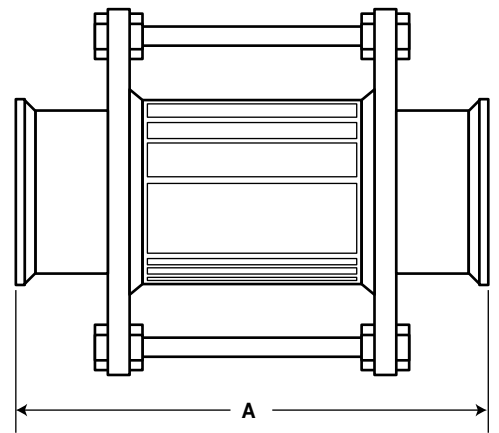

| Size<br>(Tube O.D.) | Dimension<br>A | STOCK NO.    |
|---------------------|----------------|--------------|
|                     |                | Flange Style |
| 1/2                 | 3              | 381905C      |
| 3/4                 | 3              | 381907C      |
| 1                   | 3-5/8          | 381910C      |
| 1-1/2               | 3-5/8          | 381915C      |
| 2                   | 3-5/8          | 381920C      |
| 2-1/2               | 3-5/8          | 381925C      |
| 3                   | 3-5/8          | 381930C      |
| 4                   | 3-5/8          | 381940C      |

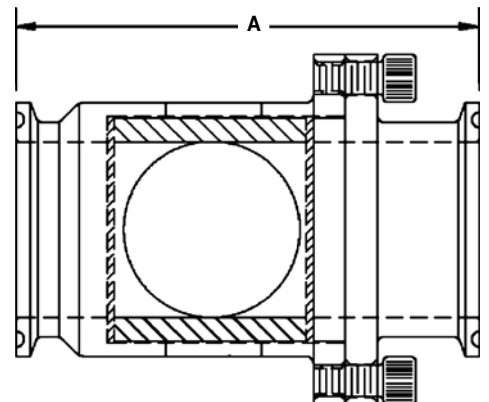

# TOP-FLO® TF-C Series Centrifugal Pumps (3-A)



Determining the model number of your pump is easy as 1-2-3-4.

|   |               |             |             |
|---|---------------|-------------|-------------|
| TF-C<br>↑<br>①  | 216<br>↑<br>② | M<br>↑<br>③ | D<br>↑<br>④ |
| <b>① PUMP SERIES</b><br>TF-C Close Coupled  |               |             |             |
| <b>② PUMP MODEL</b><br><br>*TF-C100, TF-C114, TF-C216, TF-C218, TF-C328<br><br>Note: <ul style="list-style-type: none"> <li>• TF-C Series furnished without legs unless otherwise specified on order.</li> <li>• Casing Gaskets: BUNA (Standard). If other type is required, specify on order.</li> <li>• Enlarged inlet: When ordering pump with enlarged inlet, state inlet size, i.e., TF-C218MD with 3" inlet.</li> </ul> |               |             |             |
| <b>③ PORT CONNECTIONS</b><br><br>M - Clamp (Standard)<br>T - Acme Bevel Seat Thread<br>S - NPT Female Thread<br>F - Flanged<br>W - Weld   |               |             |             |
| <b>TYPE OF SEAL/STANDARD MATERIAL:</b><br><br><b>④</b> D - External balanced sanitary seal<br>DG - External balanced seal with clamped-in seat (sanitary)<br>E - Water cooled balanced double seal<br>F - External balanced seal w/cascading water  |               |             |             |

Motor Data is not included as part of 4-step ordering number.

Provide the following information:

- Horsepower and RPM
- Electrical phase and voltage
- TEFC is standard

If motor is furnished from another source, supply the following:

- Horsepower
- RPM
- NEMA frame size

Remember to order needed accessories:

- Seal kits and parts
- Gaskets
- Clamps
- Hangers
- Air relief valves
- Check valves
- Butterfly valves
- Ball valves
- Fittings

\* Clamp end and D seal only.

Motors, VFD and pump carts available upon request.

[topln.co/cent](http://topln.co/cent)

# TOP-FLO® TF-C Series Centrifugal Pumps



## SEAL SPECIFICATIONS:

**TYPE D**  
External  
Balanced  
Seal

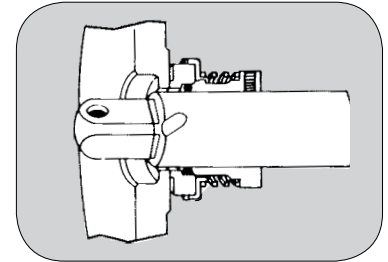

This versatile seal has numerous applications but yet is extremely durable. Dairy products, soft vegetables, beverages, and even acid cleaning solutions and detergents are among the recommended uses.

| Model No. | TF-C100 | TF-C114    | TF-C216    | TF-C218 | TF-C328 |
|-----------|---------|------------|------------|---------|---------|
| Inlet     | 1-1/2   | 1-1/2 or 2 | 2 or 2-1/2 | 2 or 3  | 3 or 4  |
| Outlet    | 1       | 1-1/2      | 1-1/2      | 1-1/2   | 2       |
| Max. Imp. | 3.68    | 4          | 6          | 8       | 8       |

## PUMP SPECIFICATIONS:

Capacity: 10gpm to 600gpm  
Pressure: 135 PSIG  
Viscosity: 200cp  
Temperature: 212°F

### Pump Casings:

- Volute type - Standard
- Inlet-oversizing as noted in chart above

### Pump Connections:

#### SANITARY:

- Clamp
- Bevel Seat (ACME)

#### INDUSTRIAL:

- Threaded
- Flanged

### Pump Construction Materials:

- All wetted parts - 316L SS
- Seals - carbon (other seals available)
- Casing gasket - Buna (Standard)
- FKM, EPDM, and PTFE are available

### Pump Finishes:

- Polished or electropolished
- 32Ra standard

### Pump Seals:

- Available in D, DG, E, and F styles

### Motor, Electrical:

- 3 Phase - 230/460 volts - 1750 & 3500 rpm
- Single Phase - 115/230 volts - 1750 & 3500 rpm
- Other voltage available upon request

### Motor Housings:

- TEFC (totally enclosed fan cooled)
- Washdown duty
- Other styles available on request

## TYPE DG

External balanced seal with clamped-in seat

The DG seal uses the standard type D rotating seal components with a reversible silicon carbide, tungsten carbide or ceramic seat. Typical applications include liquid sugar, beverage syrup, chocolate, and abrasive products.

## TYPE E

Water Cooled  
Balanced  
Double Seal

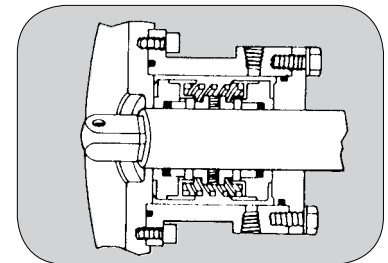

Type E is designed to withstand heavy duty vacuum applications (to 28" Hg), tacky products, slurries, or pumped products up to 212°F. The seal chamber can be pressurized to permit use of drain piping for coolants and sealants. Coolant or sealant can be circulated through the seal chamber under very low pressure when used to cool the seal face or seal against vacuum.

## TYPE F

Seal same as type D seal except includes a water cascade (not shown).

## TYPE IS

Internal seal for C114

For pump maintenance manual, go to [topln.co/pumpmanual](http://topln.co/pumpmanual)

For pump curves, go to [topln.co/curves](http://topln.co/curves)

For detailed technical information, go to [topln.co/cent](http://topln.co/cent)

For pump quote, go to [topln.co/pumpdata](http://topln.co/pumpdata)

For pump seal, go to [topln.co/pumpsealvideo](http://topln.co/pumpsealvideo)

For pump wiring, go to [topln.co/datasheet](http://topln.co/datasheet)

For pump assembly, go to [topln.co/pumpassemblyvideo](http://topln.co/pumpassemblyvideo)

# TOP-FLO® TF-C Series Close-Coupled Pump Dimensions

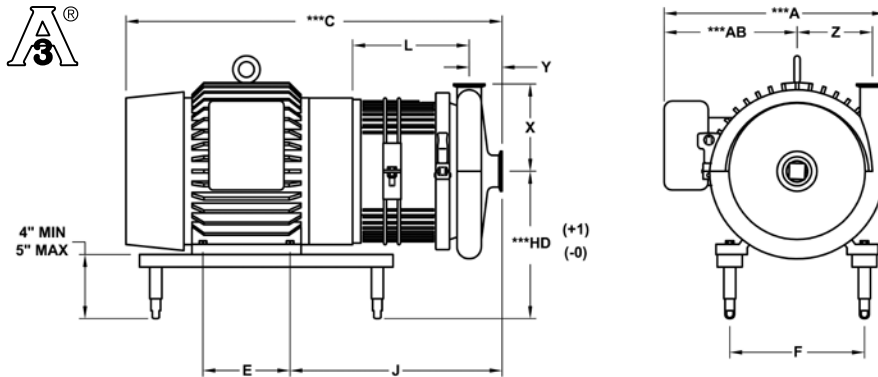

## PUMP DIMENSIONS

| PUMP MODEL | SUCTION | DISCHARGE | *X    | *Y    | **X   | **Y   | Z     |
|------------|---------|-----------|-------|-------|-------|-------|-------|
| TF-C100    | 1.500   | 1.000     | 3.500 | 1.554 |       |       | 1.453 |
| TF-C114    | 1.500   | 1.500     | 3.625 | 1.594 | 3.875 | 1.844 | 2.625 |
| TF-C216    | 2.000   | 1.500     | 4.500 | 1.906 | 4.750 | 2.156 | 3.688 |
| TF-C218    | 2.000   | 1.500     | 5.500 | 1.719 | 5.750 | 1.969 | 4.750 |
| TF-C328    | 3.000   | 2.000     | 5.500 | 2.219 | 5.750 | 2.719 | 4.750 |

## PUMP AND MOTOR DIMENSIONS WITH "WASHDOWN" TOTALLY ENCLOSED BALDOR MOTORS

| PUMP MODEL | FRAME  | A      | *C     | **C    | HD     | AB     | *J     | E      | F      | L     |
|------------|--------|--------|--------|--------|--------|--------|--------|--------|--------|-------|
| TF-C100    | 56C    | 8.313  | 13.312 |        | 7.500  | 5.000  | 6.875  | 3.000  | 4.875  | 2.750 |
|            |        |        |        |        |        |        |        |        |        |       |
| TF-C114    | 56C    | 8.313  | 16.821 | 17.071 | 7.500  | 5.000  | 10.375 | 3.000  | 4.875  | 6.219 |
|            | 143 TC | 8.563  | 17.813 | 18.063 | 7.500  | 5.250  | 10.844 | 4.000  | 5.500  | 6.219 |
|            | 145 TC | 8.563  | 19.848 | 18.063 | 7.500  | 5.250  | 10.688 | 5.000  | 5.500  | 6.219 |
|            | 182 TC | 9.813  | 20.938 | 21.180 | 8.500  | 5.875  | 12.219 | 4.500  | 7.500  | 6.781 |
|            | 184 TC | 9.813  | 23.790 | 24.915 | 8.500  | 5.875  | 12.000 | 5.500  | 7.500  | 6.781 |
| TF-C216    | 56C    | 8.313  | 16.976 | 17.226 | 7.500  | 5.000  | 10.531 | 3.000  | 4.875  | 6.062 |
|            | 143 TC | 8.563  | 17.968 | 18.223 | 7.500  | 5.250  | 10.844 | 4.000  | 5.500  | 6.062 |
|            | 145 TC | 8.563  | 20.003 | 20.253 | 7.500  | 5.250  | 10.844 | 5.000  | 5.500  | 6.062 |
|            | 182 TC | 9.813  | 21.157 | 21.399 | 8.500  | 5.875  | 12.219 | 4.500  | 7.500  | 6.688 |
|            | 184 TC | 9.813  | 24.009 | 24.259 | 8.500  | 5.875  | 12.219 | 5.500  | 7.500  | 6.688 |
|            | 213 TC | 12.156 | 26.487 | 26.624 | 9.250  | 7.375  | 13.969 | 5.500  | 8.500  | 7.813 |
|            | 215 TC | 12.156 | 27.864 | 28.114 | 9.250  | 7.375  | 13.969 | 7.000  | 8.500  | 7.813 |
|            | 254 TC | 16.094 | 28.533 | 28.783 | 10.250 | 9.625  | 14.594 | 8.250  | 10.000 | 8.437 |
|            | 256 TC | 16.094 | 30.163 | 30.413 | 10.250 | 9.625  | 14.594 | 10.000 | 10.000 | 8.437 |
| TF-C218    | 143 TC | 8.563  | 18.036 | 18.281 | 7.500  | 5.250  | 10.281 | 4.000  | 5.500  | 6.312 |
|            | 145 TC | 8.563  | 20.066 | 18.286 | 7.500  | 5.250  | 10.281 | 5.000  | 5.500  | 6.312 |
|            | 182 TC | 9.813  | 21.211 | 20.941 | 8.500  | 5.875  | 12.281 | 4.500  | 7.500  | 6.938 |
|            | 184 TC | 9.813  | 24.071 | 24.321 | 8.500  | 5.875  | 12.281 | 5.500  | 7.500  | 6.938 |
|            | 213 TC | 12.156 | 25.686 | 25.936 | 9.250  | 7.375  | 13.281 | 5.500  | 8.500  | 7.312 |
|            | 215 TC | 12.156 | 27.176 | 27.426 | 9.250  | 7.375  | 13.281 | 7.000  | 8.500  | 7.312 |
|            | 254 TC | 16.094 | 28.096 | 28.346 | 10.250 | 9.625  | 14.157 | 8.250  | 10.000 | 8.188 |
|            | 256 TC | 16.094 | 29.726 | 29.977 | 10.250 | 9.625  | 14.157 | 10.000 | 10.000 | 8.188 |
|            | 284 TC | 20.438 | 33.916 | 34.166 | 11.000 | 13.125 | 15.281 | 9.500  | 11.000 | 8.812 |
|            | 286 TC | 20.438 | 33.916 | 34.166 | 11.000 | 13.125 | 15.281 | 11.000 | 11.000 | 8.812 |
| TF-C328    | 182 TC | 9.813  | 22.024 | 22.524 | 8.500  | 5.875  | 13.094 | 4.500  | 7.500  | 7.250 |
|            | 184 TC | 9.813  | 24.884 | 25.384 | 8.500  | 5.875  | 13.094 | 5.500  | 7.500  | 7.250 |
|            | 213 TC | 12.156 | 26.499 | 26.999 | 9.250  | 7.375  | 14.094 | 5.500  | 8.500  | 7.625 |
|            | 215 TC | 12.156 | 29.664 | 28.489 | 9.250  | 7.375  | 14.094 | 7.000  | 8.500  | 7.625 |
|            | 254 TC | 16.094 | 28.909 | 29.409 | 10.250 | 9.625  | 15.000 | 8.250  | 10.000 | 8.500 |
|            | 256 TC | 16.094 | 30.539 | 31.039 | 10.250 | 9.625  | 15.000 | 10.000 | 10.000 | 8.500 |
|            | 284 TC | 20.438 | 34.729 | 35.229 | 11.000 | 13.125 | 16.094 | 9.500  | 11.000 | 9.125 |
|            | 286 TC | 20.438 | 34.729 | 35.229 | 11.000 | 13.125 | 16.094 | 11.000 | 11.000 | 9.125 |
|            | 324 TC | 22.375 | 37.311 | 37.811 | 12.000 | 14.125 | 17.156 | 10.500 | 12.500 | 9.812 |
|            | 326 TC | 22.375 | 37.311 | 37.811 | 12.000 | 14.125 | 17.156 | 12.000 | 12.500 | 9.812 |

\* WITH CLAMP CONNECTIONS (STANDARD)

\*\* WITH THREADED BEVEL SEAT CONNECTIONS

\*\*\* DIMENSIONS ARE FOR BALDOR WASHDOWN MOTORS

OTHER MOTOR MANUFACTURERS DIMENSIONS MAY VARY

FLANGE MOTORS

NOTE:

ALL DIMENSIONS IN INCHES

DIMENSIONS ARE APPROXIMATE AND FOR GUIDANCE ONLY

THESE DIMENSIONS ARE FOR PUMPS USING NEMA STANDARD "C" FACE MOTORS

# TOP-FLO® Pump Replacement Kits

From time to time, centrifugal pump sealing components need to be replaced. TOP-FLO® centrifugal pump replacement part kits are specifically designed to fit in the pumps of not only TOP-FLO® pumps but those of major pump suppliers. These components are rugged and will provide the necessary sealing conditions under a wide range of conditions.

In addition to the pump replacement kits, Top Line offers a complete line of replacement parts. From impellers to leg brackets, Top Line should be your first choice for replacement parts.

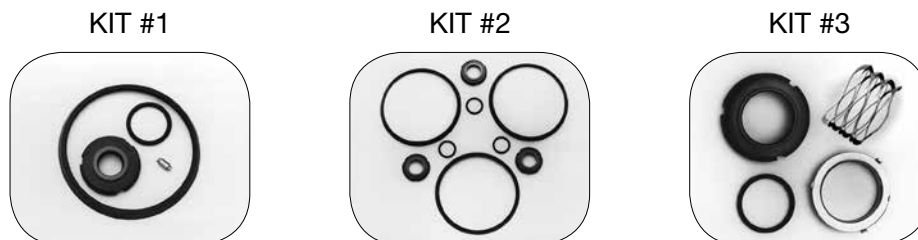

## “D” SEAL KITS

### TF-C100

|        | BUNA    | FKM     |
|--------|---------|---------|
| Kit #1 | 5629K-1 | 5629V-1 |
| Kit #2 | 5629K-2 | 5629V-2 |
| Kit #3 | 5629K-3 | 5629V-3 |

### TF-C114

|        | BUNA    | FKM     |
|--------|---------|---------|
| Kit #1 | 5649K-1 | 5649V-1 |
| Kit #2 | 5649K-2 | 5649V-2 |
| Kit #3 | 5649K-3 | 5649V-3 |

### TF-C216

|        | BUNA    | FKM     |
|--------|---------|---------|
| Kit #1 | 5669K-1 | 5669V-1 |
| Kit #2 | 5669K-2 | 5669V-2 |
| Kit #3 | 5669K-3 | 5669V-3 |

### TF-C218/C328

|        | BUNA    | FKM     |
|--------|---------|---------|
| Kit #1 | 5689K-1 | 5689V-1 |
| Kit #2 | 5689K-2 | 5689V-2 |
| Kit #3 | 5689K-3 | 5689V-3 |

**Kit #1** (Consists of 1 - Carbon Seal, 1 - Casing Gasket, 1 - O-ring, and 1 - Retaining Pin)

**Kit #2** (Consists of 3 - Carbon Seals, 3 - Casing Gaskets, and 3 - O-rings)

**Kit #3** (Consists of 1 - Carbon Seal, 1 - Spring, 1 - Cup, and 1 - O-ring)

## “DG” SEAL KITS

| TF-C114 KIT  |       |      |                                   |
|--------------|-------|------|-----------------------------------|
| 5649K-1DG    |       |      |                                   |
| CONSISTS OF: | KEY # | QTY. | DESCRIPTION                       |
| 564980       | 80    | 1    | Carbon Seal, Rotating             |
| 564924       | 24    | 1    | Impeller Retainer Pin             |
| 564980N-SC   | 80N   | 1    | Stationary Seat, Silicone Carbide |
| 564980P      | 80P   | 1    | PTFE Gasket, Outboard             |
| 564980R      | 80R   | 1    | PTFE Gasket, Inboard              |
| 564980V      | 80V   | 1    | Seal, O-ring FKM                  |
| 564990V      | 90V   | 1    | Casing Gasket, FKM                |

| TF-C216 KIT  |       |      |                                   |
|--------------|-------|------|-----------------------------------|
| 5669K-1DG    |       |      |                                   |
| CONSISTS OF: | KEY # | QTY. | DESCRIPTION                       |
| 566980       | 80    | 1    | Carbon Seal, Rotating             |
| 566924       | 24    | 1    | Impeller Retainer Pin             |
| 566980N-SC   | 80N   | 1    | Stationary Seat, Silicone Carbide |
| 566980P      | 80P   | 1    | PTFE Gasket, Outboard             |
| 566980R      | 80R   | 1    | PTFE Gasket, Inboard              |
| 566980V      | 80V   | 1    | Seal, O-ring FKM                  |
| 566990V      | 90V   | 1    | Casing Gasket, FKM                |

| TF-C218/328 KIT |       |      |                                   |
|-----------------|-------|------|-----------------------------------|
| 5689K-1DG       |       |      |                                   |
| CONSISTS OF:    | KEY # | QTY. | DESCRIPTION                       |
| 568980          | 80    | 1    | Carbon Seal, Rotating             |
| 568924          | 24    | 1    | Impeller Retainer Pin             |
| 568980N-SC      | 80N   | 1    | Stationary Seat, Silicone Carbide |
| 568980P         | 80P   | 1    | PTFE Gasket, Outboard             |
| 568980R         | 80R   | 1    | PTFE Gasket, Inboard              |
| 568980V         | 80V   | 1    | Seal, O-ring FKM                  |
| 568990V         | 90V   | 1    | Casing Gasket, FKM                |

## “E” SEAL KITS

| TF-C114 KIT  |       |      |                   |
|--------------|-------|------|-------------------|
| 5649EK-1     |       |      |                   |
| CONSISTS OF: | KEY # | QTY. | DESCRIPTION       |
| 564980       | 80    | 2    | Carbon Seal       |
| 564980V      | 80V   | 2    | Seal O-ring FKM   |
| 564980G      | 80G   | 2    | Cup (E Seal)      |
| 564917B      | 17B   | 1    | O-ring FKM        |
| 566917B      | 83E   | 1    | O-ring FKM        |
| 564980H      | 80H   | 1    | Spring (E Seal)   |
| 564990V      | 90V   | 1    | Casing Gasket FKM |

| TF-C216 KIT  |       |      |                   |
|--------------|-------|------|-------------------|
| 5669EK-1     |       |      |                   |
| CONSISTS OF: | KEY # | QTY. | DESCRIPTION       |
| 566980       | 80    | 2    | Carbon Seal       |
| 566980V      | 80V   | 2    | Seal O-ring FKM   |
| 566980G      | 80G   | 2    | Cup (E Seal)      |
| 566917B      | 17B   | 1    | O-ring FKM        |
| 566983E      | 83E   | 1    | O-ring FKM        |
| 566980H      | 80H   | 1    | Spring (E Seal)   |
| 566990V      | 90V   | 1    | Casing Gasket FKM |

| TF-C218/328 KIT |       |      |                   |
|-----------------|-------|------|-------------------|
| 5689EK-1        |       |      |                   |
| CONSISTS OF:    | KEY # | QTY. | DESCRIPTION       |
| 568980          | 80    | 2    | Carbon Seal       |
| 568980V         | 80V   | 2    | Seal O-ring FKM   |
| 568980G         | 80G   | 2    | Cup (E Seal)      |
| 568917B         | 17B   | 1    | O-ring FKM        |
| 562990V         | 83E   | 1    | O-ring FKM        |
| 568980H         | 80H   | 1    | Spring (E Seal)   |
| 568990V         | 90V   | 1    | Casing Gasket FKM |

# Pump Data Sheet

Date:

ALL FIELDS ARE NOT REQUIRED  
COMPLETE FORM TO THE BEST OF YOUR ABILITY



## Prepared By

Company:

Address:

State/Province:

Zip/Postal Code:

Phone:

Fax:

Contact Name:

Top Line Process Equipment Company  
P.O. Box 264  
Bradford, PA 16701

Phone: 814-362-4626  
Toll Free: 800-458-6095  
Fax: 814-362-4453  
www.toplineonline.com

## Sizing Data Required

Product:

Viscosity (Centipoise):

Specific Gravity:  or Product Weight (pounds per gallon):

Corrosive Material:  Yes  No Type

Gallons-Per-Minute:

Total Head: ft.  or psi

Temperature: Min. °F  Max. °F

Will Pump Perform CIP  Yes  No Chemical

Would you like Top Line to quote a motor? Washdown  TEFC  Other

No

VFD Used For Speed Control  Yes  No Voltage  Hertz  Phase

# Pump Data Sheet Continued

ALL FIELDS ARE NOT REQUIRED  
COMPLETE FORM TO THE BEST OF YOUR ABILITY

## Suction Line

Tubing Size: (Inches)

Vertical Drop (Feet):

Horizontal Run:

Total Elbows:

Tees:

Valves:

## Discharge Line

Tubing Size:

Vertical Rise:

Horizontal Run:

Total Elbows:

Tees:

Valves:

Note: Clamp connections are standard. If others required, specify

Casing Drain Required:

 Yes No

Discharge Valve: Butterfly

Ball

Disk Check

Other



# TOP-FLO® Pump Cart/Dolly

The mobility of the **TOP-FLO®** Pump Dolly allows you to find many uses in your manufacturing facility.



## SPECIFICATIONS:

- 304 SS metal components
- Bead blast finish
- Dimension 29"H x 12"W x 40.5" high
- (2) 8.0"D x 2.25"W ACM-TUFF wheels
- Right side mount cord bracket

## OPTIONAL FEATURES:

- Finishes: mechanical polish, electropolish
- Full range of control options: VFD, start/stop controls, network controls
- Wheels: non-marking white wheels, full pneumatic, solid
- Special customer design requirements

\* Wiring upgrade available

\*\* Detailed drawings available upon request

\*\* Pumps, motors, VFD, and switches sold separately

Go to [topln.co/datasheet](http://topln.co/datasheet) for wiring data sheet

[topln.co/dolly](http://topln.co/dolly)

## TOP-FLO® PUMP DOLLY CONFIGURATIONS



**DOLLY 1**  
(CUSTOMER MOUNTS MOTOR)

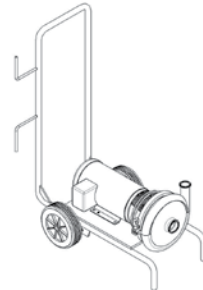

**DOLLY 2**  
(SUPPLIED WITH MOTOR MOUNTED)

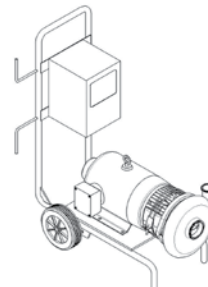

**DOLLY 3**  
(SUPPLIED WITH MOTOR & VFD MOUNTED)

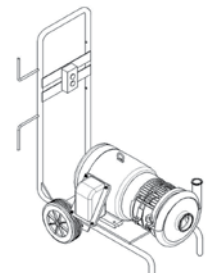

**DOLLY 4**  
(SUPPLIED WITH MOTOR & START/STOP MOUNTED)



**DOLLY 5**  
(SUPPLIED BARS FOR CUSTOMERS TO MOUNT MOTOR AND SWITCHES OR VFD)

# TOP-FLO® TL60ARV Air Relief Valve

The TL60ARV Air Relief Valve is used primarily when removal of air from a line without loss of product is a concern. The design of the TL60ARV is simple: a ferrule, a housing with a plastic ball, and a vent pipe all connected using 2 standard heavy duty clamps. This design will not let air enter the line or container under negative pressure.

The TL60ARV is double seated. The lightweight ball is freely moving and depending on pressure conditions will close against upper or lower seat. This valve is not designed for use in operation with liquids having less than 1.0 specific gravity.

The valve can be mounted on the top of a pipeline or container to bleed a pipeline where an air pocket may have formed during operation.

Bleeding a pipe on the suction side of a pump will be automatic. Air binding will be prevented. These valves are found mounted on the top of the inlet pipe in front of the pump.

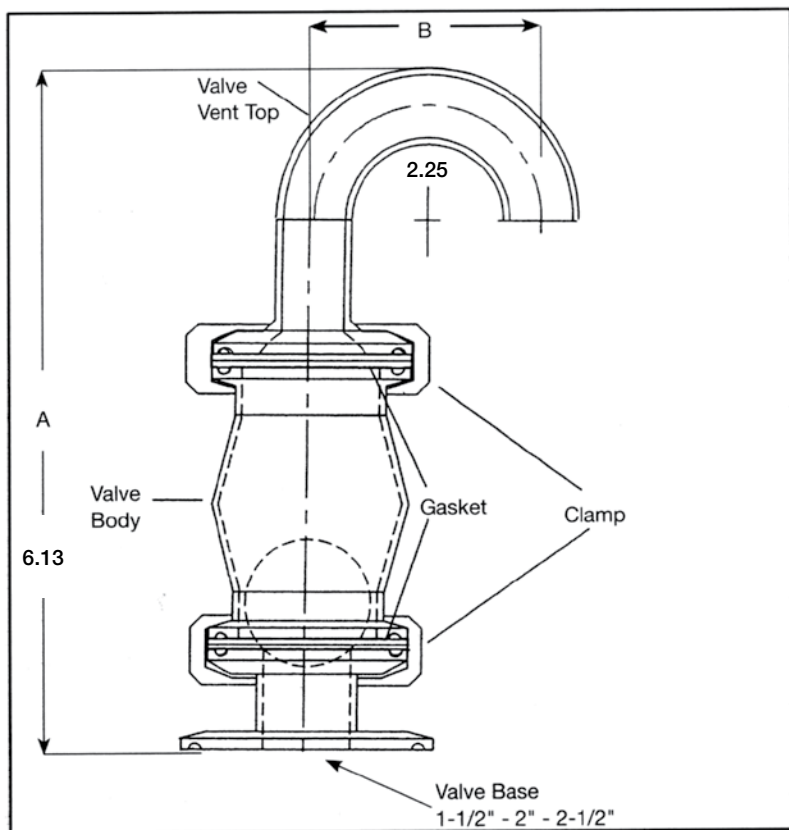

| TL60ARV Air Relief Valve 1-1/2" 386015ARV |             |      |
|---|-------------|------|
| Description                               | Part Number | Qty. |
| Vent Top                                  | 38601525VT  | 1    |
| Body                                      | 38601525    | 1    |
| Base - 1-1/2"                             | 386015      | 1    |
| Clamp                                     | 3299915     | 2    |
| Gasket (FKM)                              | 321010V     | 2    |
| Ball 1.25"                                | 38601525B   | 1    |

| TL60ARV Air Relief Valve 2" 386020ARV |             |      |
|---------------------------------------|-------------|------|
| Description                           | Part Number | Qty. |
| Vent Top                              | 38601525VT  | 1    |
| Body                                  | 38601525    | 1    |
| Base - 2"                             | 386020      | 1    |
| Clamp                                 | 3299915     | 2    |
| Gasket (FKM)                          | 321010V     | 2    |
| Ball 1.25"                            | 38601525B   | 1    |

| TL60ARV Air Relief Valve 2-1/2" 386025ARV |             |      |
|---|-------------|------|
| Description                               | Part Number | Qty. |
| Vent Top                                  | 38601525VT  | 1    |
| Body                                      | 38601525    | 1    |
| Base - 2-1/2"                             | 386025      | 1    |
| Clamp                                     | 3299915     | 2    |
| Gasket (FKM)                              | 321010V     | 2    |
| Ball 1.25"                                | 38601525B   | 1    |

**Ordering Information**  
 Steel grade .....Stainless steel, AISI 316L  
 Ball.....Polypropylene  
 Finish .....Polished to 32R<sub>a</sub>

**Technical Data**  
 Maximum product pressure ..... 150 PSI  
 Maximum temperature .....275°F  
 Net weight ..... 19 oz. (9.5 kg)  
 For proper operation:  
 • Product density must be 1.0 or higher  
 • The valve must be mounted vertically

# BPE Products (Full catalog for BPE available - [topln.co/bpeproducts](http://topln.co/bpeproducts))

## BPE Fittings

Your choice, we offer:

- BPE Compliant Made in USA
- BPE Certified Manufacturing

It's easy! Just specify which option when ordering

Top Line provides BPE fittings in sizes ranging from 1/2" through 6" in both automatic weld and hygienic clamp ends.



[topln.co/bpefittings](http://topln.co/bpefittings)

## Pharmaceutical Grade Tubing (BPE)

Top Line supplies BPE certified 316L stainless steel tubing in sizes 1/2" - 4" in 20' lengths and 6" in 19' lengths. The two internal surface finishes available are BPE SF1 (20Ra Max I.D.) and BPE SF4 (15Ra Max I.D. w/electropolish) with 30Ra external mechanical polish. All BPE tubing has controlled sulfur content to accommodate orbital welding. The tubing is bagged and capped to both maintain cleanliness and for protection during shipment.

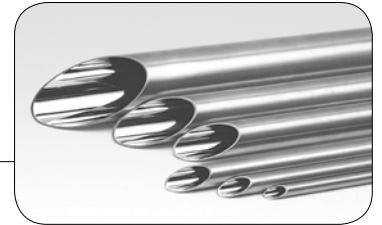

[topln.co/bpetubing](http://topln.co/bpetubing)

## TOP-FLO<sup>®</sup> Diaphragm Valves

TOP-FLO<sup>®</sup> hygienic diaphragm valves compete with the leaders in the industry and we can provide many innovative process solutions. Top Line offers standard 2-way, tandem assemblies in traditional L-pattern & Sterile Access, ZERODL<sup>®</sup> block style assemblies in T-Pattern, Point-of-Use, Divert, and Integral L-Pattern & Sterile Access, actuation, and new accessories, forged or cast, 316L stainless steel bodies.

Available in sizes 1/4" - 6"



Tank bottom valve



Access valve



Point of Use valve



Divert valve

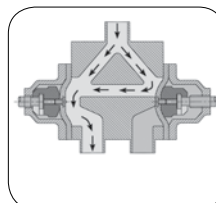

[topln.co/diaphragmvalves](http://topln.co/diaphragmvalves)

## TOP-FLO® Series 77 Ball Valves

Series 77 3-pc ball valves feature a high quality CF3M investment casting of center body and end caps with 316L ball & stem and are an excellent choice for use in clean steam systems. Valve end connections are hygienic clamp or extended butt weld type for orbital welding. Standard seals are non-cavity filled modified PTFE (MPTFE) that are FDA conforming and USP Class VI certified. Internal surface finishes available are BPE codes SF1, SF4, and SF5. All stainless valve components are fully traceable with MTR's for center body, end caps, ball, and stem. Available in sizes ½" - 4". All valves feature direct mount ISO5211 mounting pad for easy automation and stem extension installation.



[topln.co/highpurityball](http://topln.co/highpurityball)

## TOP-FLO® Sample Valves

Top Line low profile sampling valves provide minimum dead leg areas and positive shut off for sensitive fluids. Valves are available with butt weld or sanitary clamp end connections with hose barb discharge as standard. Connection sizes are ½" – 6" clamp end.

- Right Angle
- In-Line
- Eccentric



[topln.co/sample](http://topln.co/sample)

## TOP-FLO® T45MP Check Valves

The T45MP disc type 316L check valve can be used in a variety of hygienic processes depending on construction selected including product contact systems, compendial water systems, clean steam systems, and clean gas (oxygen, nitrogen, pharma clean air). Valve-end connections are hygienic clamp or extended butt weld type for orbital welding. Configurations in both concentric and eccentric outlet are available. Standard FKM internal seal material is FDA conforming and USP Class VI certified. Internal surface finishes available are BPE Codes SF1, SF4, and SF5. The size range is ½" - 8".



[topln.co/checkvi](http://topln.co/checkvi)

# Sanitary Magnetic Drive Centrifugal Pump

The MKP-Bio series mag drive pump is an excellent solution for aseptic applications such as WFI and other compendial water applications. The vertical orientation and special internal machining of components allow for drainability to the suction inlet of the pump. Multiple internal surface finishes, various static seal materials, and motor options are available to suit system requirements. The design of the pump was developed to EHEDG recommendations to provide the highest level of cleanability.



[topln.co/magdrive](http://topln.co/magdrive)

# Electropolishing

Electropolishing is an electrochemical process that removes surface metal by attacking the high points on the surface. The surface becomes smoother and any contaminants and free irons will be removed. This will improve the corrosion resistance, reduce the product adhesion and contamination buildup, deburr, and create a lustrous finish.



[topln.co/electropolishing](http://topln.co/electropolishing)

# Custom Fabrications

Top Line's skilled craftsmen and specialized equipment combine to produce a wide variety of custom fabricated stainless steel process flow components. All specials are made to customer requirements and are available in a wide variety of sanitary finishes.

We specialize in:

- Custom sanitary spool pieces
- Dip tubes
- Diaphragm valves
- Strainers
- Tubing
- Special tees
- Custom fittings
- Manifolds
- Machine parts



[topln.co/custom](http://topln.co/custom)

For more information, download our full Pharmaceutical & Biotechnology Catalog at [topln.co/bpe](http://topln.co/bpe)



# Allegheny Bradford Family of Companies



The ABC family of companies consists of four operating divisions: **Allegheny Bradford Corporation, Top Line Process Equipment Company, Allegheny Surface Technology, and ABC Actini**. Each division delivers the highest level of quality, along with the technical support, professional expertise, and dedicated service you expect. Our focus is to meet or exceed the most stringent standards in the food, beverage, and dairy processing industries. We combine unsurpassed excellence with single-source convenience and value.

## History:

The company started as Top Line Corporation supplying dairy equipment to the dairy farms and dairy process industries nationwide. It was originally founded and located in Janesville, Wisconsin in the 1950s. In 1962, Top Line moved its headquarters to Lewis Run, Pennsylvania and began to market stainless steel components to the food and beverage industry through a network of distributors. This formed the new operating division named Top Line Process Equipment Company. Allegheny Bradford Corporation was originally formed to supply stainless steel flow equipment to both Top Line divisions. Allegheny Bradford went on to become its own operating division manufacturing custom equipment to the pharmaceutical and biotechnology industries.

**[www.abccorporate.com](http://www.abccorporate.com) • 800-542-0650 / 814-362-2590**



Manufacturers and fabricators of the highest quality heat exchangers, filter housings, tanks, pressure vessels, process systems, and custom fabrication in stainless steel and high nickel alloy for end users and OEMs.

**[www.alleghenybradford.com](http://www.alleghenybradford.com) • 800-542-0650 / 814-362-2590**



A leader in metal surface finishing. For decades, Allegheny Surface Technology has been providing our customers with outstanding service in electropolishing, pickling, passivation, and mechanical polishing. Allegheny Surface Technology will develop the best solution for your application. We currently process components for the pharmaceutical, chemical, food & beverage, electronic, architectural, and automotive industries

**[www.alleghenysurface.com](http://www.alleghenysurface.com) • 866-266-9293**



Always giving you  
top of the line  
service and quality.

Contact your Top Line Representative for Assistance

Office: P.O. Box 264 · Bradford, PA 16701

Plant: 21 Valley Hunt Drive · Lewis Run, PA 16738

800-458-6095

814-362-4626

Fax: 814-362-4453

## This is what our customers are saying about us:

We have been working with Top Line for about 20 years.

Haleson Distributes quality sanitary equipment across Canada, working with pharmaceutical customers as well as food and beverage accounts.

The team at Top Line are great people that we consider friends. They understand the sanitary business very well and have helped Haleson win countless jobs with great pricing, selection of products and engineering support.

We have enjoyed working with Top Line and intend to continue our relationship for a very long time.

You can count on Top Line. They are great.

George Palov, *Sales Manager / Gerant des ventes*

Why do we stick with Top Line?

Westco has provided and installed Top Line tubing, fittings, components, and pumps for over 20 years to major food, beverage, dairy and pharmaceutical plants and R&D facilities throughout New York, New Jersey, Pennsylvania, and New England. It's our primary business. Top Line product quality is second to none in the industry. Their inside sales and engineering staff know high standards of our industry and we can rely on them to provide the right products, on time, and at a fair price. They have provided overnight shipping and weekend emergency service and support to help us to help our customers out of major jams many times over the years. Top Line is there for us and that's why we stick with them!

Matt Burra, *Westco FG Corp.*

**Top Line** is the leading supplier of sanitary stainless steel process equipment serving the food, beverage, dairy, pharmaceutical, biotechnology and personal care industries. For over 50 years we've provided our customers with exceptional customer service and quality products. We are committed to meeting the fastest delivery, new product development and application engineering to meet all our customer's needs with our extensive inventory and expert sales team.

## Limited Warranty

Top Line Process Equipment Company products are warranted to be free of defects in material or workmanship for a period of one year from date of shipment. Warranty covers those Top Line products used in an approved installation and maintained in strict accordance with recognized standard industry practice. If, after properly authorized return, Top Line determines that products are defective, Top Line may at its option, repair or replace such defective products.

Top Line shall not be liable for consequential, indirect or incidental damages. The above warranty is in lieu of all other warranties, expressed or implied.



[www.toplineonline.com](http://www.toplineonline.com)